



**THE DATASHEET OF
TLV62090RGTT**



TLV62090 3A High Efficiency Synchronous Step-Down Converter with DCS-Control™

1 Features

- 2.5 V to 5.5 V Input Voltage Range
- DCS-Control™
- Up To 98% Efficiency
- Power Save Mode
- 20 μ A Operating Quiescent Current
- 100% Duty Cycle for Lowest Dropout
- 1.4 MHz Typical Switching Frequency
- 0.8 V to V_{IN} Adjustable Output Voltage
- Output Discharge Function
- Adjustable Softstart
- Hiccup Short Circuit Protection
- Output Voltage Tracking
- Pin-to-Pin Compatible with [TPS62090](#), [TLV62095](#) and [TPS62095](#)
- For Improved Feature Set, See [TPS62090](#)
- Create a Custom Design using the TLV62090 with the [WEBENCH® Power Designer](#)

2 Applications

- Distributed Power Supplies
- Notebook, Netbook Computers
- Hard Disk Drives (HDD)
- Solid State Drives (SSD)
- Processor Supply
- Battery Powered Applications

3 Description

The TLV62090 device is a high frequency synchronous step-down converter optimized for small solution size, high efficiency and suitable for battery powered applications. To maximize efficiency, the converter operates in pulse width modulation (PWM) mode with a nominal switching frequency of 1.4 MHz and it automatically enters power save mode operation at light load currents. When used in distributed power supplies and point of load regulation, the device allows voltage tracking to other voltage rails and tolerates output capacitors ranging from 10 μ F up to 150 μ F and beyond. Using the DCS-Control topology, the device achieves excellent load transient performance and accurate output voltage regulation.

The output voltage start-up ramp is controlled by the softstart pin, which allows operation as either a standalone power supply or in tracking configurations. Power sequencing is also possible by configuring the enable (EN) and power good (PG) pins. In power save mode, the device operates with typically 20- μ A quiescent current. Power save mode is entered automatically and seamlessly, maintaining high efficiency over the entire load current range.

The device is available in a 3 mm x 3 mm 16-pin VQFN (RGT) package.

Device Information⁽¹⁾

PART NUMBER	PACKAGE	BODY SIZE (NOM)
TLV62090	VQFN (16)	3.00 mm x 3.00 mm

(1) For all available packages, see the orderable addendum at the end of the datasheet.

Typical Application Schematic

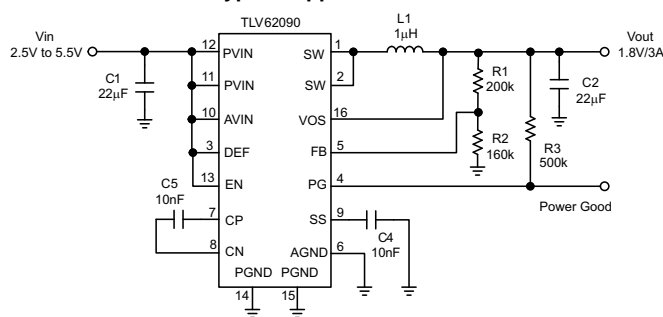

Efficiency vs Output Current

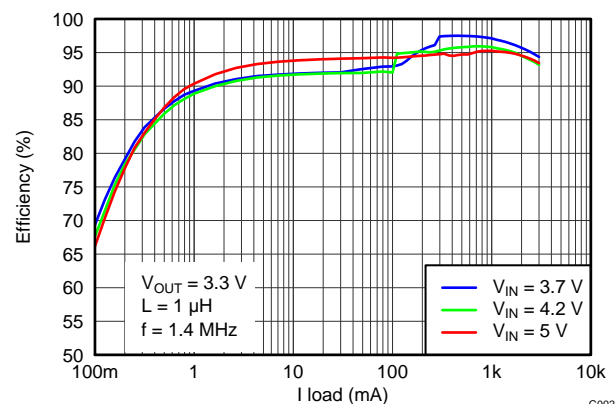

G002



Table of Contents

1 Features	1	8 Application and Implementation	14
2 Applications	1	8.1 Application Information.....	14
3 Description	1	8.2 Typical Application	14
4 Revision History	2	9 Power Supply Recommendations	20
5 Pin Configuration and Functions	4	10 Layout	21
6 Specifications	5	10.1 Layout Guideline	21
6.1 Absolute Maximum Ratings	5	10.2 Layout Example	21
6.2 ESD Ratings	5	11 Device and Documentation Support	22
6.3 Recommended Operating Conditions.....	5	11.1 Device Support.....	22
6.4 Thermal Information	5	11.2 Documentation Support	22
6.5 Electrical Characteristics.....	6	11.3 Receiving Notification of Documentation Updates	22
6.6 Typical Characteristics.....	7	11.4 Community Resources.....	22
7 Detailed Description	9	11.5 Trademarks	22
7.1 Overview	9	11.6 Electrostatic Discharge Caution.....	22
7.2 Functional Block Diagram	9	11.7 Glossary	23
7.3 Feature Description.....	10	12 Mechanical, Packaging, and Orderable	Information
7.4 Device Functional Modes.....	13		23

4 Revision History

NOTE: Page numbers for previous revisions may differ from page numbers in the current version.

Changes from Revision E (January 2016) to Revision F	Page
• Added <i>Feature</i> : Pin-to-Pin Compatible with TPS62090, TLV62095 and TPS62095	1
• Added <i>Feature</i> : For Improved Feature Set, See TPS62090.....	1
• Added WEBENCH information to the <i>Features</i> , <i>Detailed Design Procedure</i> , and <i>Device Support</i> sections	1
• Added SW (AC, less than 10 ns) to the <i>Absolute Maximum Rating</i> table	5
• Added additional frequency curves to the <i>Typical Characteristics</i> section	7
• Added Table 1 , Power Good Pin Logic	12

Changes from Revision D (September 2015) to Revision E	Page
• Changed title From: <i>3A High Efficient Synchronous</i> To: <i>3A High Efficiency Synchronous</i>	1
• Changed <i>Features</i> From: 95% Converter Efficiency To: Up To 98% Efficiency.....	1
• Changed <i>Features</i> From: Two Level Short Circuit Protection To: Hiccup Short Circuit Protection	1
• Changed text in the <i>Description</i> From: the device operates at typically 20 μ A quiescent current. To: the device operates with typically 20- μ A quiescent current.	1
• Deleted Note from the pinout drawing: <i>The exposed Thermal Pad is connected to AGND.</i>	4
• Changed the <i>Pin Functions</i> table I/O column.....	4
• Changed the <i>Pin Functions</i> table Description column for pins FB, EN, and Thermal Pad	4
• Added pins CN and CP to the Voltage range in <i>Absolute Maximum Ratings</i> ⁽¹⁾	5
• Deleted "Continuous total power dissipation" from <i>Absolute Maximum Ratings</i> ⁽¹⁾	5
• Deleted Note 1 from <i>Recommended Operating Conditions</i>	5
• Added EN = Low to the Description of R _{PD} in <i>Electrical Characteristics</i> table.....	6
• Deleted I _{PG} from the <i>Electrical Characteristics</i> table	6
• Changed L _{IMF} to I _{LIMF} for High side FET switch current limit in the <i>Electrical Characteristics</i> table.....	6
• Changed V _s to V _{OUT} for Output voltage range in the <i>Electrical Characteristics</i> table.....	6
• Changed Figure 1 through Figure 2	7
• Added Note 1 to the <i>Functional Block Diagram</i>	9

• Changed "Softstart (SS) and Output Capacitor during Startup" To: Softstart (SS) and Hiccup Current Limit During Startup	10
• Changed text From: "start-up especially for larger output capacitors >22 μ F." To: "start-up especially for larger output capacitors." in Softstart (SS) and Hiccup Current Limit During Startup	10
• Rewrite the description in Voltage Tracking (SS)	10
• Deleted text "in PFM mode and with a minimum quiescent current while" from Power Save Mode Operation	13
• Changed $V_{OUT(max)}$ to V_{OUT} in Equation 4	13
• Deleted text " $V_{OUT(max)}$ = nominal output voltage plus maximum output voltage tolerance" from Equation 4	13
• Added Note to Application and Implementation	14
• Added 10 nF to the description of C4, C5 in Table 3	15
• Updated the Isat/DCR (max) column of Table 5	16
• Deleted text" The inductor needs to be rated for a saturation current as high as the typical switch current limit, of 4.6 A or according to Equation 5 and Equation 6 ." from Inductor Selection	16
• Changed Equation 5 and Equation 6	16
• Changed the Input and Output Capacitor Selection section	16
• Changed Figure 19	18
• Changed Figure 20	18

Changes from Revision C (May 2014) to Revision D
Page

• Moved Storage temperature From: ESD Ratings To: Absolute Maximum Ratings ⁽¹⁾	5
• Changed table From: Handling Ratings To: ESD Ratings	5
• Added PWM mode, $T_J = 25^\circ\text{C}$ to Feedback voltage accuracy section of the Electrical Characteristics table	6

Changes from Revision B (April 2012) to Revision C
Page

• Added ESD Ratings table, Feature Description section, Device Functional Modes , Application and Implementation section, Power Supply Recommendations section, Layout section, Device and Documentation Support section, and Mechanical, Packaging, and Orderable Information section.	1
• Deleted text: "TPS62090 adjustable output version" from the Feedback voltage accuracy section of the Electrical Characteristics table	6
• Changed Figure 1 From: Resistance (Ω) To: Resistance ($m\Omega$)	7
• Added Application Curves to the Application Information section	18
• Deleted Typical applications from the Application Information section for: 1.8 V Adjustable Version, 1.5 V Adjustable Version, 1.2 V Adjustable Version and 1.05 V Adjustable Version	20

Changes from Revision A (March 2012) to Revision B
Page

• Changed the Input voltage range MAX value From: 6V To 5.5V in Electrical Characteristics	6
--	---

Changes from Original (March 2012) to Revision A
Page

• Changed V_{in} From: 2.5V to 6V To: 2.5V to 5.5V in Figure 11	14
---	----

5 Pin Configuration and Functions

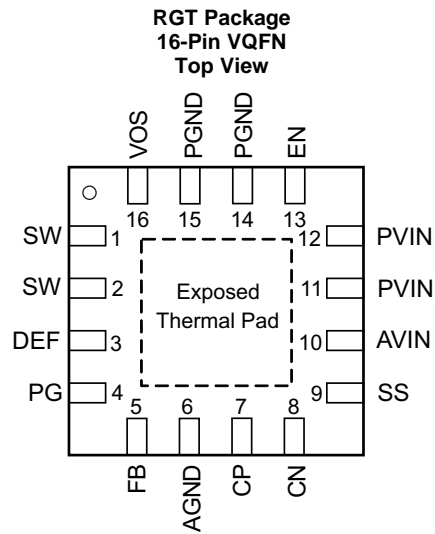

Pin Functions

PIN		I/O	DESCRIPTION
NAME	NO.		
SW	1, 2	I/O	Switch pin of the power stage.
DEF	3	I	This pin is used for internal logic and needs to be pulled high. This pin should not be left floating.
PG	4	O	Power good open drain output. This pin is high impedance if the output voltage is within regulation. This pin is pulled low if the output is below its nominal value. The pull up resistor can not be connected to any voltage higher than the input voltage of the device.
FB	5	I	Feedback pin of the device. Connect a resistor divider to set the output voltage.
AGND	6		Analog ground.
CP	7	I/O	Internal charge pump flying capacitor. Connect a 10 nF capacitor between CP and CN.
CN	8	I/O	Internal charge pump flying capacitor. Connect a 10 nF capacitor between CP and CN.
SS	9	I	Softstart control pin. A capacitor is connected to this pin and sets the softstart time. Leaving this pin floating sets the minimum start-up time.
AVIN	10	I	Bias supply input voltage pin.
PVIN	11,12	I	Power supply input voltage pin.
EN	13	I	Device enable. To enable the device this pin needs to be pulled high. Pulling this pin low disables the device. This pin has a pull down resistor of typically 400 kΩ, which is active when EN is low.
PGND	14,15		Power ground connection.
VOS	16	I	Output voltage sense pin. This pin needs to be connected to the output voltage.
Exposed Thermal Pad			The exposed thermal pad is connected to AGND. It must be soldered for mechanical reliability.

6 Specifications

6.1 Absolute Maximum Ratings⁽¹⁾

		VALUE		UNIT
		MIN	MAX	
Voltage range ⁽²⁾	PVIN, AVIN, FB, SS, EN, DEF, VOS	- 0.3	7	V
	SW (DC), PG	- 0.3	V _{IN} + 0.3	
	SW (AC, less than 10 ns) ⁽³⁾	- 3.0	10	
	CN, CP	- 0.3	V _{IN} + 7	
Power Good sink current	PG		1	mA
Operating junction temperature range, T _J		- 40	150	°C
Storage temperature, T _{stg}		- 65	150	°C

- (1) Stresses beyond those listed under “absolute maximum ratings” may cause permanent damage to the device. These are stress ratings only and functional operation of the device at these or any other conditions beyond those indicated under “recommended operating conditions” is not implied. Exposure to absolute–maximum–rated conditions for extended periods may affect device reliability.
- (2) All voltage values are with respect to network ground terminal.
- (3) While switching

6.2 ESD Ratings

			MAX	UNIT
V _(ESD)	Electrostatic discharge	Human body model (HBM), per ANSI/ESDA/JEDEC JS-001, all pins ⁽¹⁾	±2000	V
		Charged device model (CDM), per JEDEC specification JESD22-C101, all pins ⁽²⁾	±500	

- (1) JEDEC document JEP155 states that 500-V HBM allows safe manufacturing with a standard ESD control process.
- (2) JEDEC document JEP157 states that 250-V CDM allows safe manufacturing with a standard ESD control process.

6.3 Recommended Operating Conditions

		MIN	TYP	MAX	UNIT
V _{IN}	Input voltage range V _{IN}	2.5		5.5	V
T _A	Operating ambient temperature	-40		85	°C
T _J	Operating junction temperature	-40		125	°C

6.4 Thermal Information

THERMAL METRIC ⁽¹⁾		TLV62090	UNITS
		VQFN (16 PINS)	
R _{θJA}	Junction-to-ambient thermal resistance	47	°C/W
R _{θJC(top)}	Junction-to-case (top) thermal resistance	60	
R _{θJB}	Junction-to-board thermal resistance	20	
Ψ _{JT}	Junction-to-top characterization parameter	1.5	
Ψ _{JB}	Junction-to-board characterization parameter	20	
R _{θJC(bot)}	Junction-to-case (bottom) thermal resistance	5.3	

- (1) For more information about traditional and new thermal metrics, see the [Semiconductor and IC Package Thermal Metrics](#) application report.

6.5 Electrical Characteristics

 $V_{IN} = 3.6V$, $T_A = -40^{\circ}C$ to $85^{\circ}C$, typical values are at $T_A = 25^{\circ}C$ (unless otherwise noted)

PARAMETER		TEST CONDITIONS	MIN	TYP	MAX	UNIT
SUPPLY						
V_{IN}	Input voltage range		2.5		5.5	V
I_{QIN}	Quiescent current	Not switching, FB = FB +5%, into PVIN and AVIN		20		μA
I_{sd}	Shutdown current	Into PVIN and AVIN		0.6	5	μA
V_{UVLO}	Undervoltage lockout threshold	V_{IN} falling	2.1	2.2	2.3	V
	Undervoltage lockout hysteresis			200		mV
T_{SD}	Thermal shutdown	Temperature rising		150		$^{\circ}C$
	Thermal shutdown hysteresis			20		$^{\circ}C$
CONTROL SIGNAL EN						
V_H	High level input voltage	$V_{IN} = 2.5 V$ to $5.5 V$	1	0.65		V
V_L	Low level input voltage	$V_{IN} = 2.5 V$ to $5.5 V$		0.60	0.4	V
I_{lkg}	Input leakage current	EN = GND or V_{IN}		10	100	nA
R_{PD}	Pull down resistance	EN = Low		400		k Ω
SOFTSTART						
I_{SS}	Softstart current		6.3	7.5	8.7	μA
POWER GOOD						
V_{TH_PG}	Power good threshold	Output voltage rising	93%	95%	97%	
		Output voltage falling	88%	90%	92%	
V_L	Low level voltage	$I_{(sink)} = 1 mA$			0.4	V
I_{lkg}	Leakage current	$V_{PG} = 3.6 V$		10	100	nA
POWER SWITCH						
$R_{DS(on)}$	High side FET on-resistance	$I_{SW} = 500 mA$		50		m Ω
	Low side FET on-resistance	$I_{SW} = 500 mA$		40		m Ω
I_{LIMF}	High side FET switch current limit		3.7	4.6	5.5	A
f_s	Switching frequency	$I_{OUT} = 3 A$		1.4		MHz
OUTPUT						
V_{OUT}	Output voltage range		0.8		V_{IN}	V
R_{od}	Output discharge resistor	EN = GND, $V_{OUT} = 1.8 V$		200		Ω
V_{FB}	Feedback regulation voltage	PWM Mode		0.8		V
V_{FB}	Feedback voltage accuracy $V_{IN} \geq V_{OUT} + 1 V$	$I_{OUT} = 1 A$, PWM mode, $T_J = 25^{\circ}C$	-1%		+1%	
		$I_{OUT} = 1 A$, PWM mode	-1.4%		+1.4%	
		$I_{OUT} = 0 mA$, $V_{OUT} \geq 1.2 V$, PFM mode ⁽¹⁾	-1.4%		+3%	
		$I_{OUT} = 0 mA$, $V_{OUT} < 1.2 V$, PFM mode ⁽²⁾	-1.4%		+3.7%	
I_{FB}	Feedback input bias current	$V_{FB} = 0.8 V$		10	100	nA
	Line regulation	$V_{OUT} = 1.8 V$, PWM operation		0.016		%/V
	Load regulation	$V_{OUT} = 1.8 V$, PWM operation		0.04		%/A

(1) Conditions: L = 1 μH , $C_{OUT} = 22 \mu F$. For more information, see the [Power Save Mode Operation](#) section of this data sheet.

(2) For output voltages < 1.2 V, use a 2 x 22 μF output capacitance to achieve +3% output voltage accuracy in PFM mode.

6.6 Typical Characteristics

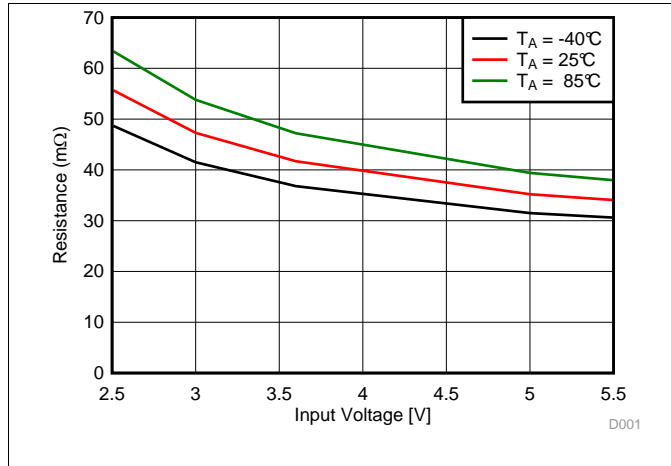

Figure 1. High Side FET On-Resistance vs Input Voltage

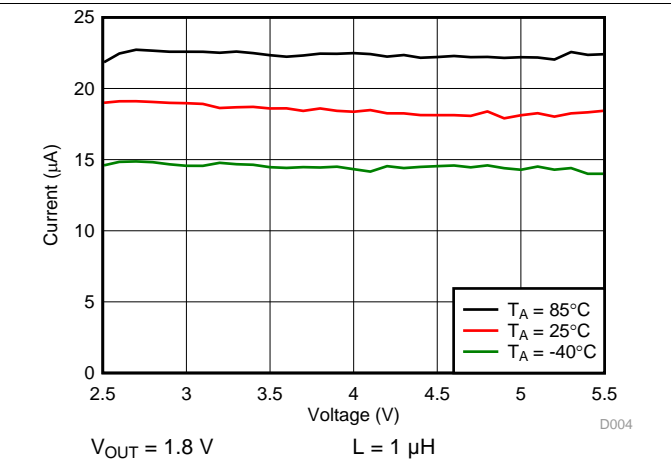

Figure 2. Quiescent Current vs Input Voltage

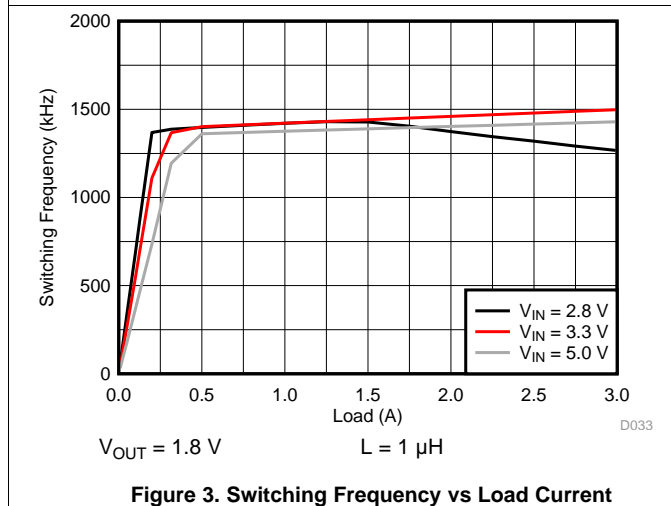

Figure 3. Switching Frequency vs Load Current

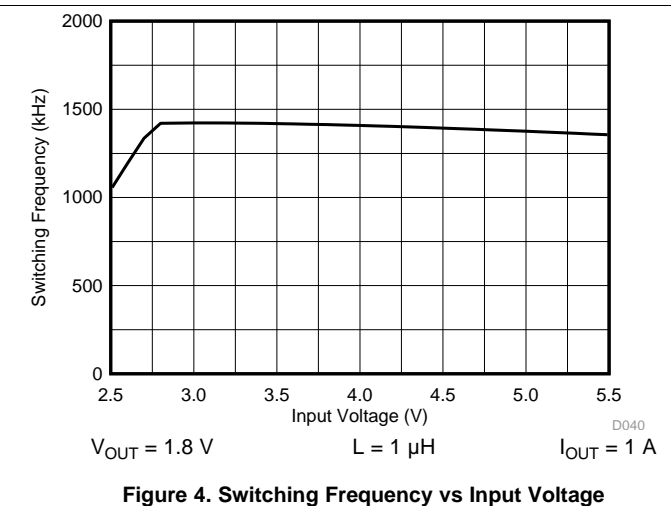

Figure 4. Switching Frequency vs Input Voltage

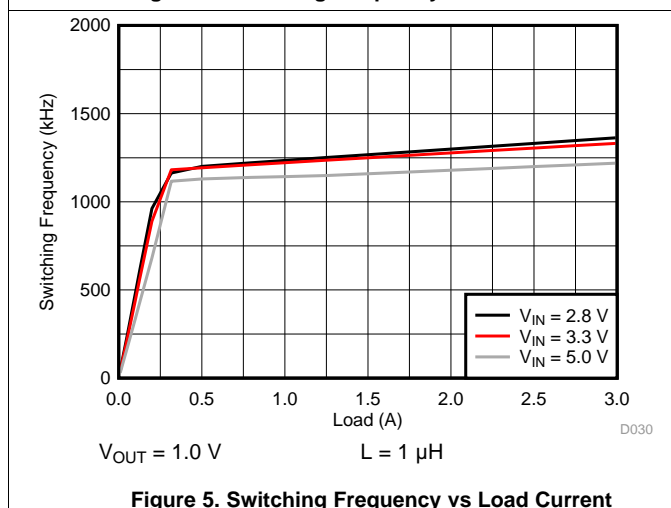

Figure 5. Switching Frequency vs Load Current

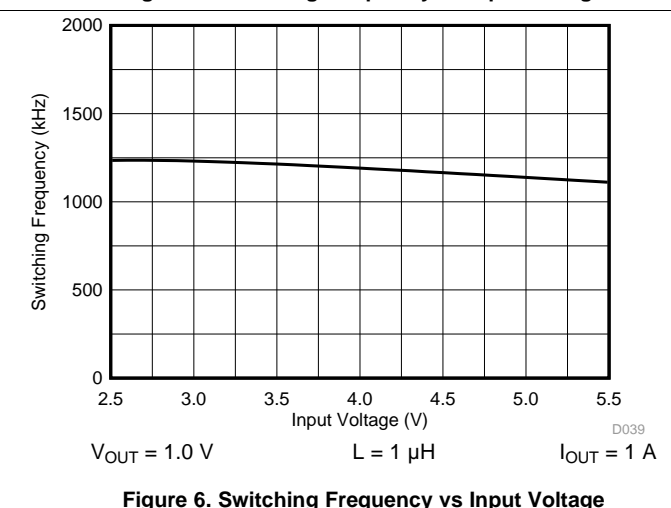
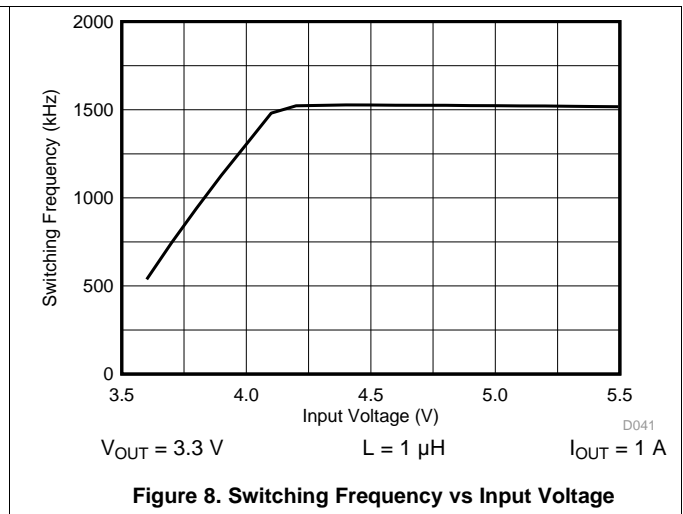
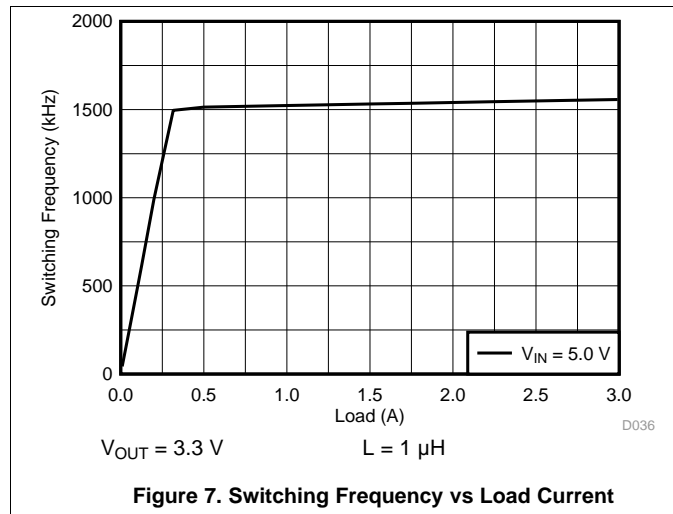

Figure 6. Switching Frequency vs Input Voltage

Typical Characteristics (continued)



7 Detailed Description

7.1 Overview

The TLV62090 synchronous switched mode converter is based on DCS-Control™ (direct control with seamless transition into power save mode). This is an advanced regulation topology that combines the advantages of hysteretic and voltage-mode control.

The DCS-Control™ topology operates in pulse width modulation (PWM) mode for medium to heavy load conditions and in power save mode at light load currents. In PWM mode, the converter operates with its nominal switching frequency of 1.4 MHz having a controlled frequency variation over the input voltage range. As the load current decreases, the converter enters power save mode, reducing the switching frequency and minimizing the current consumption to achieve high efficiency over the entire load current range. DCS-Control™ supports both operation modes (PWM and PFM) using a single building block having a seamless transition from PWM to power save mode without effects on the output voltage. The TLV62090 offers excellent DC voltage regulation and load transient regulation, combined with low output voltage ripple, minimizing interference with RF circuits.

7.2 Functional Block Diagram

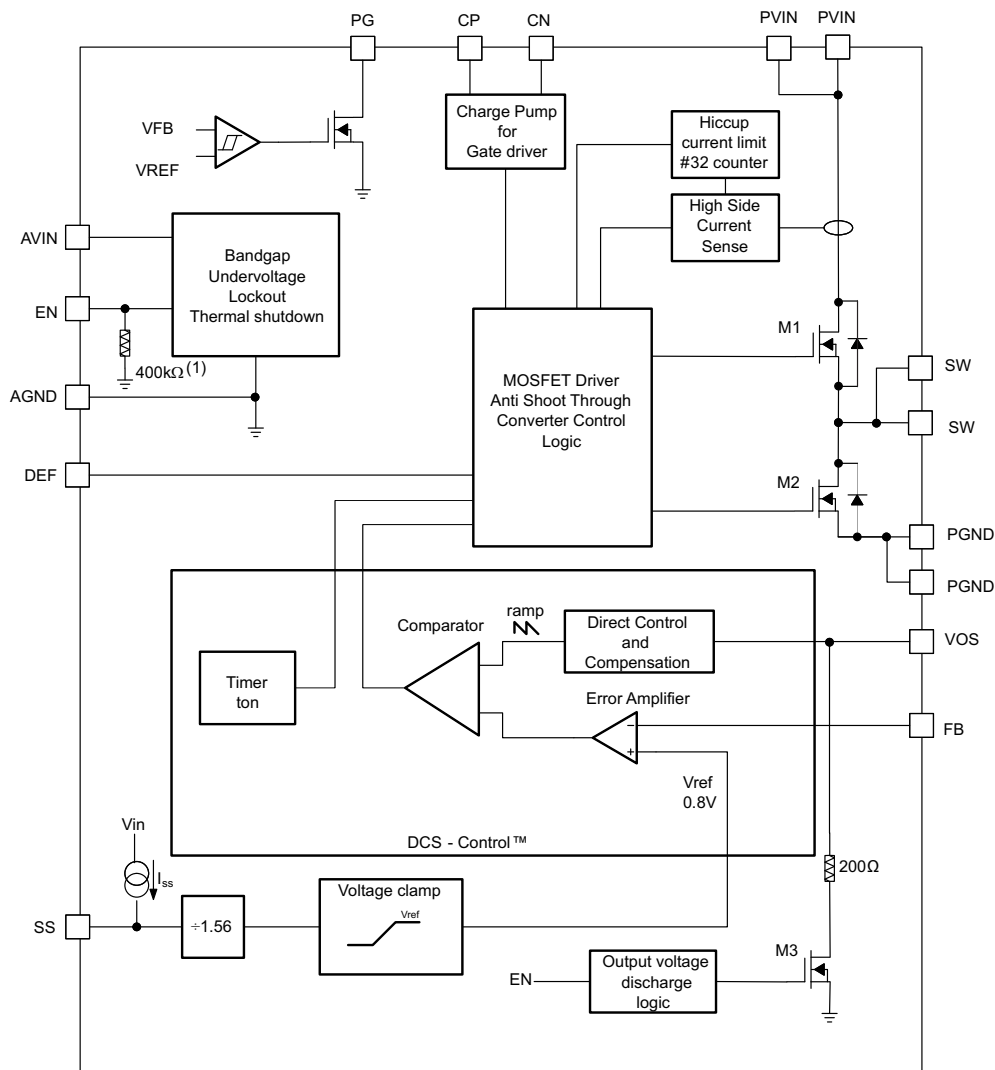

Copyright © 2017, Texas Instruments Incorporated

(1) The resistor is disconnected when EN is high.

7.3 Feature Description

7.3.1 Enable (EN)

The device is enabled by setting the EN pin to a logic high. Accordingly, shutdown mode is forced if the EN pin is pulled low with a shutdown current of typically 0.6 μA . In shutdown mode, the internal power switches as well as the entire control circuitry are turned off. An internal resistor of 200 Ω discharges the output through the VOS pin smoothly. An internal pull-down resistor of 400 $\text{k}\Omega$ is connected to the EN pin when the EN pin is low. The pull-down resistor is disconnected when the EN pin is high.

7.3.2 Softstart (SS) and Hiccup Current Limit During Startup

To minimize inrush current during start up, the device has an adjustable softstart depending on the capacitor value connected to the SS pin. The device charges the softstart capacitor with a constant current of typically 7.5 μA . The feedback voltage follows this voltage with a fraction of 1.56 until the internal reference voltage of 0.8 V is reached. Softstart operation is completed once the voltage at the softstart capacitor has reached typically 1.25 V. The softstart time is calculated using [Equation 1](#). The larger the softstart capacitor, the longer the softstart time. The relation between softstart voltage and feedback voltage is estimated using [Equation 2](#).

$$t_{\text{SS}} = C_{\text{SS}} \times \frac{1.25\text{V}}{7.5\mu\text{A}} \quad (1)$$

$$V_{\text{FB}} = \frac{V_{\text{SS}}}{1.56} \quad (2)$$

During startup, the switch current limit is reduced to 1/3 (~1.5 A) of its typical current limit of 4.6 A. Once the output voltage exceeds typically 0.6 V, the current limit is released to its nominal value. The device provides a reduced load current of ~1.5 A when the output voltage is below typically 0.6 V. Due to this, a small or no softstart time may trigger the short circuit protection during startup especially for larger output capacitors. This is avoided by using a larger softstart capacitance to extend the softstart time. See [Short Circuit Protection \(Hiccup-Mode\)](#) for details of the reduced current limit during startup. Leaving the softstart pin floating sets the minimum startup time (around 50 μs).

7.3.3 Voltage Tracking (SS)

The SS pin is externally driven by another voltage source to achieve output voltage tracking. The application circuit is shown in [Figure 9](#). The internal reference voltage follows the voltage at the SS pin with a fraction of 1.56 until the internal reference voltage of 0.8 V is reached. The device achieves ratiometric or coincidental (simultaneous) output tracking, as shown in [Figure 10](#).

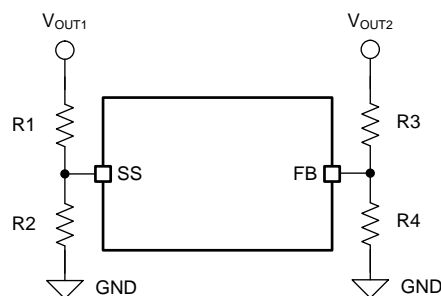

Copyright © 2017, Texas Instruments Incorporated

Figure 9. Output Voltage Tracking

Feature Description (continued)

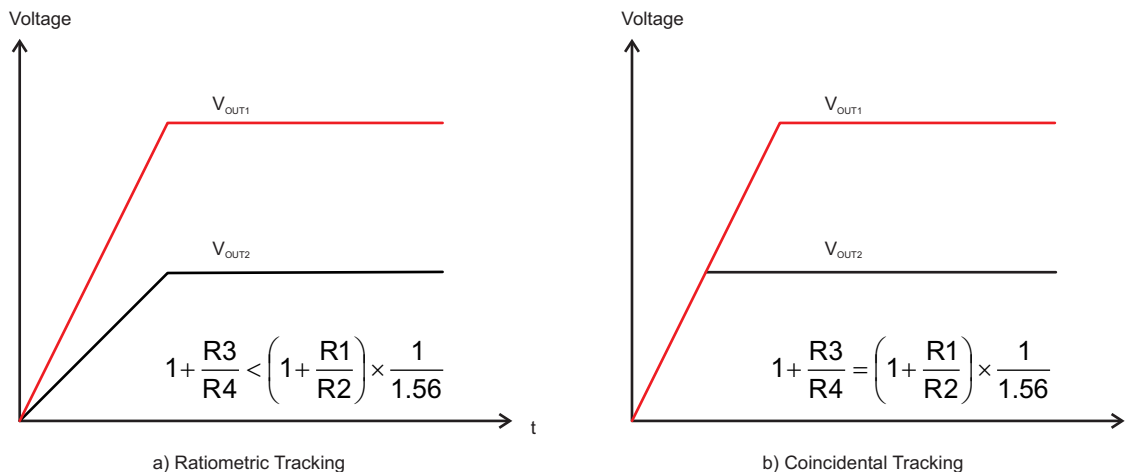

Figure 10. Voltage Tracking Options

The R2 value should be set properly to achieve accurate voltage tracking by taking 7.5 μA soft startup current into account. 1 kΩ or smaller is a sufficient value for R2.

For decreasing the SS pin voltage, the device doesn't sink current from the output when the device is in power save mode. So the resulting decreases of the output voltage may be slower than the SS pin voltage if the load is light. When driving the SS pin with an external voltage, do not exceed the voltage rating of the SS pin which is 7 V.

7.3.4 Short Circuit Protection (Hiccup-Mode)

The device is protected against hard short circuits to GND and over-current events. This is implemented by a two level short circuit protection. During startup and when the output is shorted to GND, the switch current limit is reduced to 1/3 of its typical current limit of 4.6 A. Once the output voltage exceeds typically 0.6 V, the current limit is released to its nominal value. The full current limit is implemented as a hiccup current limit. Once the internal current limit is triggered 32 times, the device stops switching and starts a new startup sequence after a typical delay time of 66 μS. The device goes through these cycles until the high current condition is released.

7.3.5 Output Discharge Function

To make sure the device starts up under defined conditions, the output gets discharged via the VOS pin with a typical discharge resistor of 200 Ω whenever the device shuts down. This happens when the device is disabled or if thermal shutdown, undervoltage lockout or short circuit hiccup-mode are triggered.

Feature Description (continued)

7.3.6 Power Good Output (PG)

The power good output is low when the output voltage is below its nominal value. The power good becomes high impedance once the output is within 5% of regulation. The PG pin is an open drain output and is specified to typically sink up to 1 mA. This output requires a pull-up resistor to be monitored properly. The pull-up resistor cannot be connected to any voltage higher than the input voltage of the device. The PG output is low when the device is disabled, in thermal shutdown or UVLO. The PG output can be left floating if unused. [Table 1](#) shows the PG pin logic.

Table 1. Power Good Pin Logic

Device State		PG Logic Status	
		High Impedance	Low
Enable (EN=High)	$V_{FB} \geq V_{TH_PG}$	√	
	$V_{FB} \leq V_{TH_PG}$		√
Shutdown (EN=Low)			√
UVLO	$0.7\text{ V} < V_{IN} \leq V_{UVLO}$		√
Thermal Shutdown	$T_J > T_{SD}$		√
Power Supply Removal	$V_{IN} \leq 0.7\text{ V}$	√	

7.3.7 Undervoltage Lockout (UVLO)

To avoid mis-operation of the device at low input voltages, an undervoltage lockout is included. UVLO shuts down the device at input voltages lower than typically 2.2 V with a 200 mV hysteresis.

7.3.8 Thermal Shutdown

The device goes into thermal shutdown once the junction temperature exceeds typically 150°C with a 20°C hysteresis.

7.3.9 Charge Pump (CP, CN)

The CP and CN pins must attach to an external 10 nF capacitor to complete a charge pump for the gate driver. This capacitor must be rated for the input voltage. It is not recommended to connect any other circuits to the CP or CN pins.

7.4 Device Functional Modes

7.4.1 PWM Operation

At medium to heavy load currents, the device operates with pulse width modulation (PWM) at a nominal switching frequency of 1.4 MHz. As the load current decreases, the converter enters power save mode operation reducing its switching frequency. The device enters power save mode at the boundary to discontinuous conduction mode (DCM).

7.4.2 Power Save Mode Operation

As the load current decreases, the converter enters power save mode operation. During power save mode, the converter operates with reduced switching frequency maintaining high efficiency. Power save mode is based on a fixed on-time architecture following [Equation 3](#).

$$\begin{aligned}
 t_{on} &= \frac{V_{OUT}}{V_{IN}} \times 360\text{ns} \times 2 \\
 f &= \frac{2 \times I_{OUT}}{t_{on}^2 \left(1 + \frac{V_{IN} - V_{OUT}}{V_{OUT}} \right) \times \frac{V_{IN} - V_{OUT}}{L}}
 \end{aligned} \tag{3}$$

In power save mode, the output voltage rises slightly above the nominal output voltage in PWM mode, as shown in [Figure 15](#). This effect is reduced by increasing the output capacitance or the inductor value. This effect is also reduced by programming the output voltage of the TLV62090 lower than the target value. As an example, if the target output voltage is 3.3 V, then the TLV62090 can be programmed to 3.3 V - 0.8%. As a result the output voltage accuracy is now -2.2% to +2.2% instead of -1.4% to 3%. The output voltage accuracy in pulse frequency modulation (PFM) operation is reflected in the electrical specification table and given for a 22-μF output capacitor.

7.4.3 Low Dropout Operation (100% Duty Cycle)

The device offers a low input to output voltage difference by entering 100% duty cycle mode. In this mode, the high-side MOSFET switch is constantly turned on. This is particularly useful in battery powered applications to achieve longest operation time by taking full advantage of the whole battery voltage range. The minimum input voltage where the output voltage falls below its nominal regulation value is given by:

$$V_{IN(\min)} = V_{OUT} + I_{OUT} \times (R_{DS(on)} + R_L) \tag{4}$$

Where

$R_{DS(on)}$ = High side FET on-resistance

R_L = DC resistance of the inductor

8 Application and Implementation

NOTE

Information in the following applications sections is not part of the TI component specification, and TI does not warrant its accuracy or completeness. TI's customers are responsible for determining suitability of components for their purposes. Customers should validate and test their design implementation to confirm system functionality.

8.1 Application Information

The TLV62090 is a 3-A high frequency synchronous step-down converter optimized for small solution size, high efficiency and suitable for battery powered applications.

8.2 Typical Application

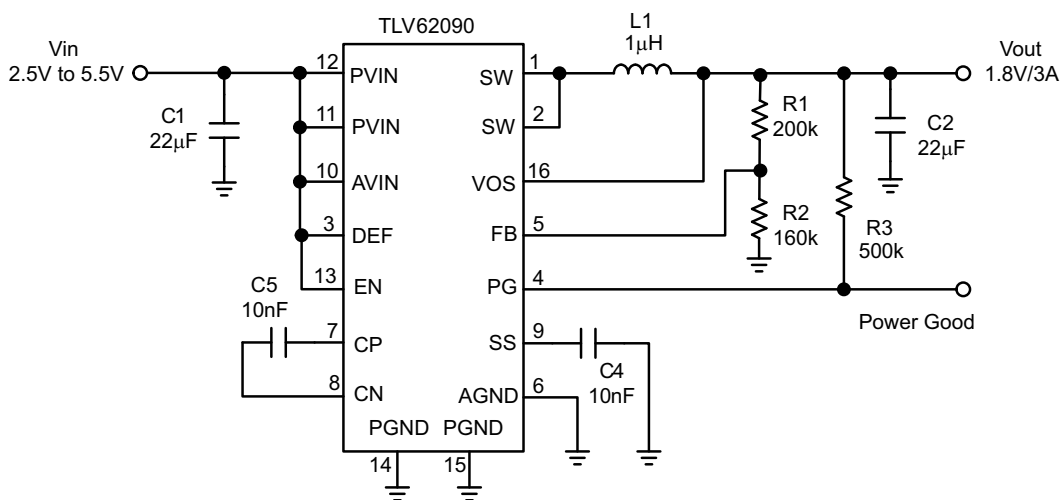

Copyright © 2017, Texas Instruments Incorporated

Figure 11. TLV62090 Typical Application Circuit

8.2.1 Design Requirements

The design guideline provides a component selection to operate the device within the recommended operating conditions.

For the typical application example, the following input parameters are used. See [Table 2](#).

Table 2. Design Parameters

DESIGN PARAMETERS	EXAMPLE VALUES
Input Voltage Range	2.5 V to 5.5 V
Output Voltage	1.8 V
Transient Response	±5% VOUT
Input Voltage Ripple	400 mV
Output Voltage Ripple	30 mV
Output current rating	3 A
Operating frequency	1.4 MHz

Table 3 shows the list of components for the Application Characteristic Curves.

Table 3. List of Components

REFERENCE	DESCRIPTION	MANUFACTURER
TLV62090	High efficiency step-down converter	Texas Instruments
L1	Inductor: 1 μ H	Coilcraft XFL4020-102
C1	Ceramic capacitor: 22 μ F	(6.3V, X5R, 0805)
C2	Ceramic capacitor: 22 μ F	(6.3V, X5R, 0805)
C4, C5	Ceramic capacitor, 10 nF	Standard
R1, R2, R3	Resistor	Standard

8.2.2 Detailed Design Procedure

8.2.2.1 Custom Design with WEBENCH® Tools

[Click here](#) to create a custom design using the TLV62090 device with the WEBENCH® Power Designer.

1. Start by entering your V_{IN} , V_{OUT} , and I_{OUT} requirements.
2. Optimize your design for key parameters like efficiency, footprint and cost using the optimizer dial and compare this design with other possible solutions from Texas Instruments.
3. The WEBENCH Power Designer provides you with a customized schematic along with a list of materials with real time pricing and component availability.
4. In most cases, you will also be able to:
 - Run electrical simulations to see important waveforms and circuit performance
 - Run thermal simulations to understand the thermal performance of your board
 - Export your customized schematic and layout into popular CAD formats
 - Print PDF reports for the design, and share your design with colleagues
5. Get more information about WEBENCH tools at www.ti.com/WBENCH.

The first step is the selection of the output filter components. To simplify this process, [Table 4](#) outlines possible inductor and capacitor value combinations.

Table 4. Output Filter Selection

INDUCTOR VALUE [μ H] ⁽¹⁾	OUTPUT CAPACITOR VALUE [μ F] ⁽²⁾				
	10	22	47	100	150
0.47		√	√	√	√
1.0	√	√ ⁽³⁾	√	√	√
2.2	√	√	√	√	√
3.3					

- (1) Inductor tolerance and current de-rating is anticipated. The effective inductance can vary by +20% and –30%.
- (2) Capacitance tolerance and bias voltage de-rating is anticipated. The effective capacitance can vary by +20% and –50%.
- (3) Typical application configuration. Other check mark indicates alternative filter combinations

8.2.2.2 Inductor Selection

The inductor selection is affected by several parameters like inductor ripple current, output voltage ripple, transition point into power save mode, and efficiency. See [Table 5](#) for typical inductors.

Table 5. Inductor Selection

INDUCTOR VALUE	COMPONENT SUPPLIER	SIZE (LxWxH mm)	I _{sat} /DCR (max)
0.6 μH	Coilcraft XAL4012-601	4 x 4 x 2.1	7.9A/10.5 mΩ
1 μH	Coilcraft XAL4020-102	4 x 4 x 2.1	6.7A/14.6 mΩ
1 μH	Coilcraft XFL4020-102	4 x 4 x 2.1	4.5 A/11.9 mΩ
0.47 μH	TOKO DFE252012CR47	2.5 x 2 x 1.2	3.7A/39 mΩ
1 μH	TOKO DFE252012C1R0	2.5 x 2 x 1.2	3.0A/59 mΩ
0.68 μH	TOKO DFE322512CR68	3.2 x 2.5 x 1.2	3.5A/35 mΩ
1 μH	TOKO DFE322512C1R0	3.2 x 2.5 x 1.2	3.1A/45 mΩ

In addition, the inductor has to be rated for the appropriate saturation current and DC resistance (DCR). [Equation 5](#) and [Equation 6](#) calculate the maximum inductor current under static load conditions. The formula takes the converter efficiency into account. The converter efficiency can be taken from the data sheet graphs or 80% can be used as a conservative approach. The calculation must be done for the maximum input voltage where the peak switch current is highest.

$$\Delta I_L = \frac{V_{OUT}}{\eta} \times \left(1 - \frac{V_{OUT}}{V_{IN} \times \eta} \right) \div (f \times L) \quad (5)$$

$$I_{PEAK} = I_{OUT} + \frac{\Delta I_L}{2} \quad (6)$$

where

f = Converter switching frequency (typically 1.4 MHz)

L = Selected inductor value

η = Estimated converter efficiency (use the number from the efficiency curves or 0.80 as a conservative assumption)

Calculating the maximum inductor current using the actual operating conditions gives the minimum saturation current. A margin of about 20% should be added to cover for load transients during operation.

8.2.2.3 Input and Output Capacitor Selection

For best output and input voltage filtering, low ESR (X5R or X7R) ceramic capacitors are recommended. The input capacitor minimizes input voltage ripple, suppresses input voltage spikes and provides a stable system rail for the device. A 22-μF or larger input capacitor is recommended. The output capacitor value can range from 10 μF up to 150 μF and beyond. Load transient testing and measuring the bode plot are good ways to verify stability with larger capacitor values.

The recommended typical output capacitor value is 22 μF (nominal) and can vary over a wide range as outline in the output filter selection table. For output voltages above 1.8 V, noise can cause duty cycle jitter. This does not degrade device performance. Using an output capacitor of 2 x 22 μF (nominal) for output voltages >1.8 V avoids duty cycle jitter.

Ceramic capacitor have a DC-Bias effect, which has a strong influence on the final effective capacitance. Choose the right capacitor carefully in combination with considering its package size and voltage rating.

8.2.2.4 Setting the Output Voltage

The output voltage is set by an external resistor divider according to the following equations:

$$V_{\text{OUT}} = V_{\text{FB}} \times \left(1 + \frac{R1}{R2} \right) = 0.8 \text{ V} \times \left(1 + \frac{R1}{R2} \right) \quad (7)$$

$$R2 = \frac{V_{\text{FB}}}{I_{\text{FB}}} = \frac{0.8 \text{ V}}{5 \mu\text{A}} \approx 160 \text{ k}\Omega \quad (8)$$

$$R1 = R2 \times \left(\frac{V_{\text{OUT}}}{V_{\text{FB}}} - 1 \right) = R2 \times \left(\frac{V_{\text{OUT}}}{0.8\text{V}} - 1 \right) \quad (9)$$

When sizing R2, in order to achieve low quiescent current and acceptable noise sensitivity, use a minimum of 5 μA for the feedback current I_{FB} . Larger currents through R2 improve noise sensitivity and output voltage accuracy. A feed forward capacitor is not required for proper operation.

8.2.3 Application Curves

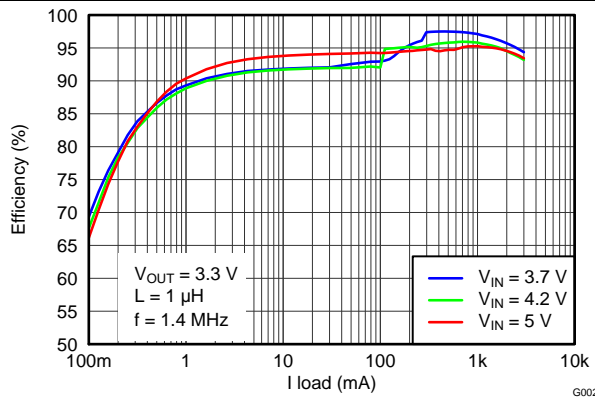

Figure 12. Efficiency vs Load Current

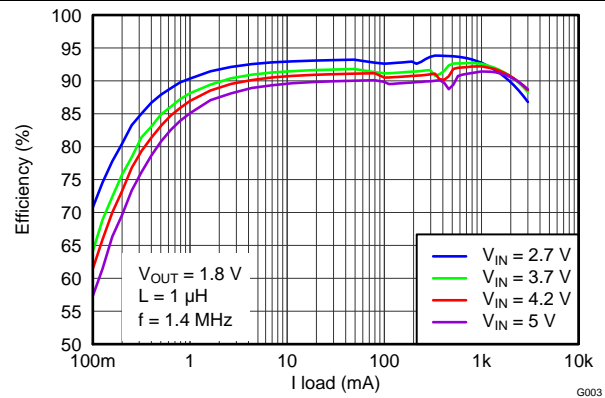

Figure 13. Efficiency vs Load Current

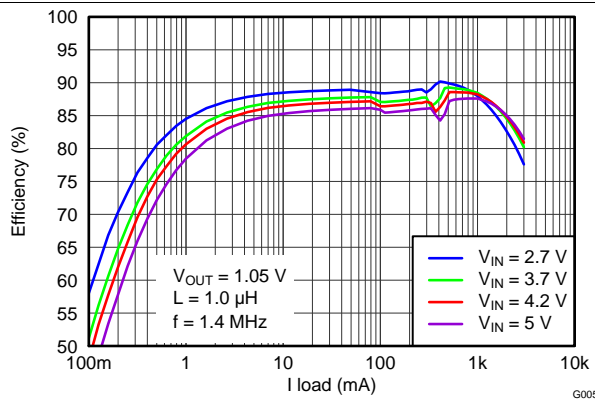

Figure 14. Efficiency vs Load Current

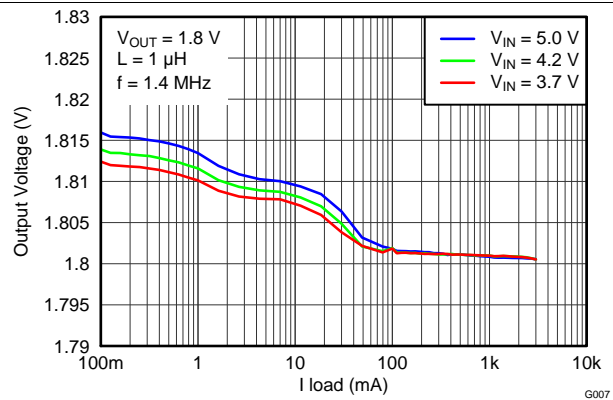

Figure 15. Output Voltage vs Load Current

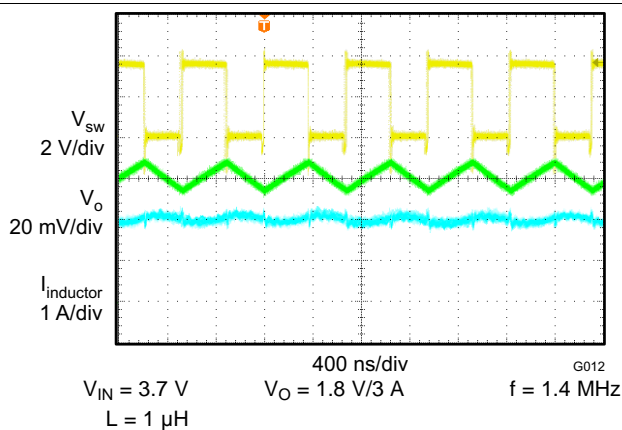

Figure 16. PWM Operation

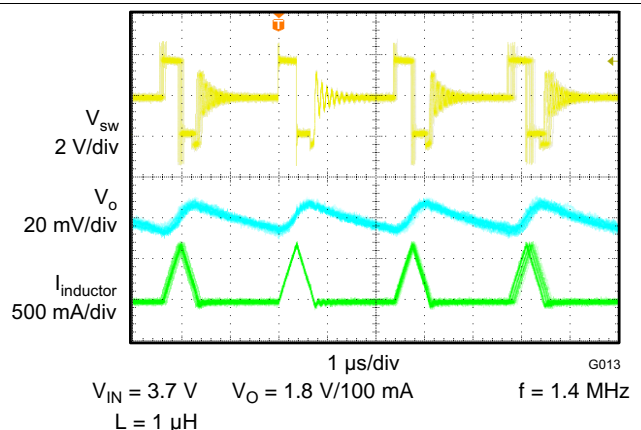

Figure 17. PFM Operation

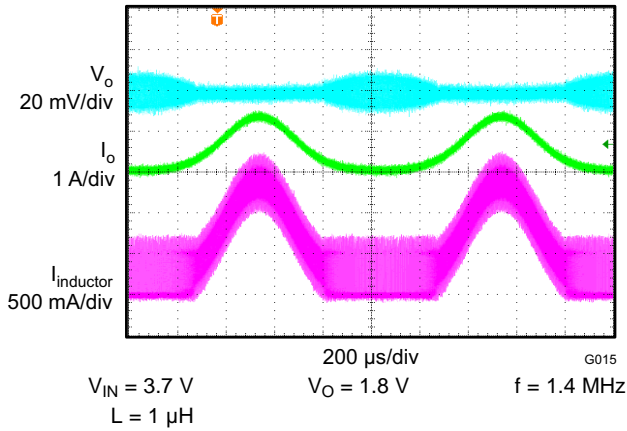

Figure 18. Load Sweep, 0 to 1.5 A

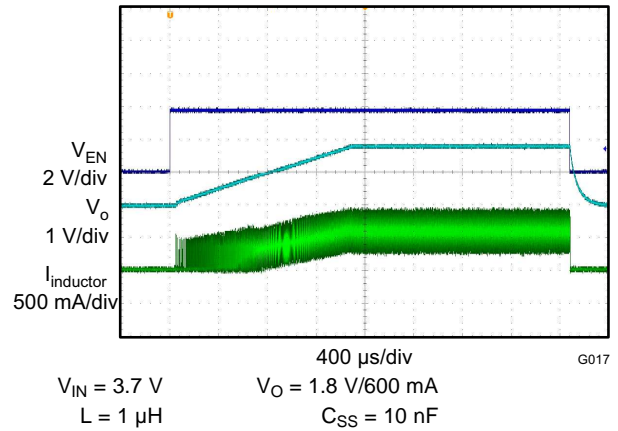

Figure 19. Start-Up

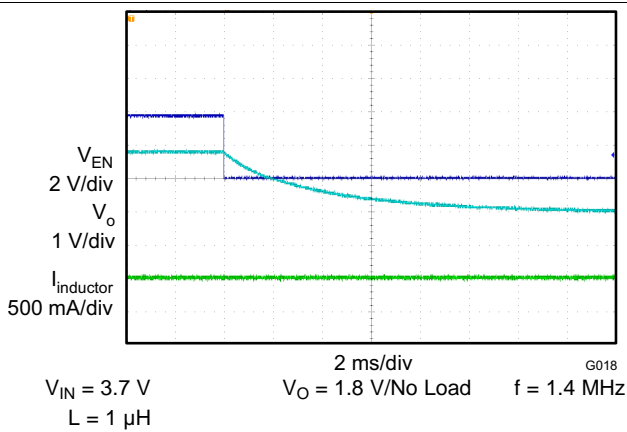

Figure 20. Shutdown

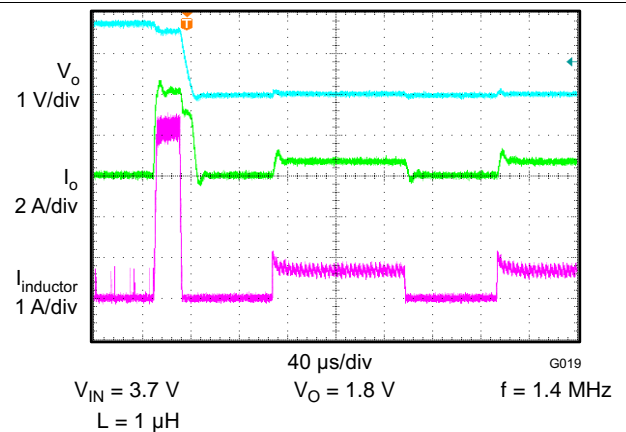

Figure 21. Hiccup Short Circuit Protection

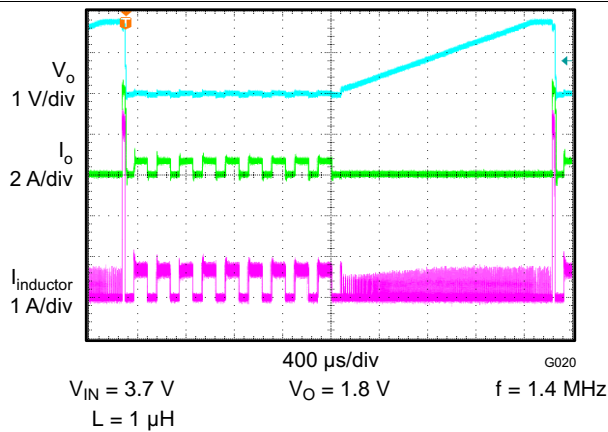

Figure 22. Hiccup Short Circuit Protection

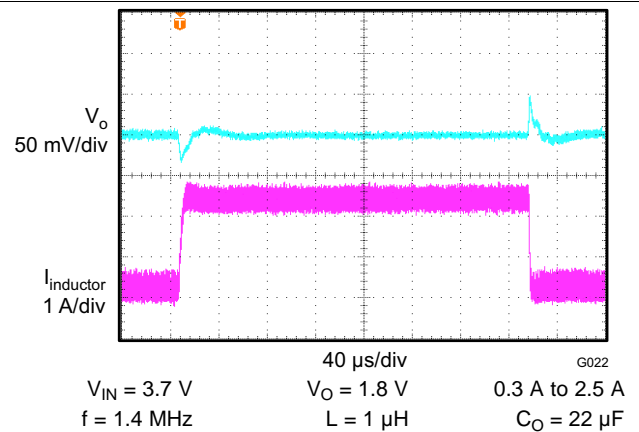
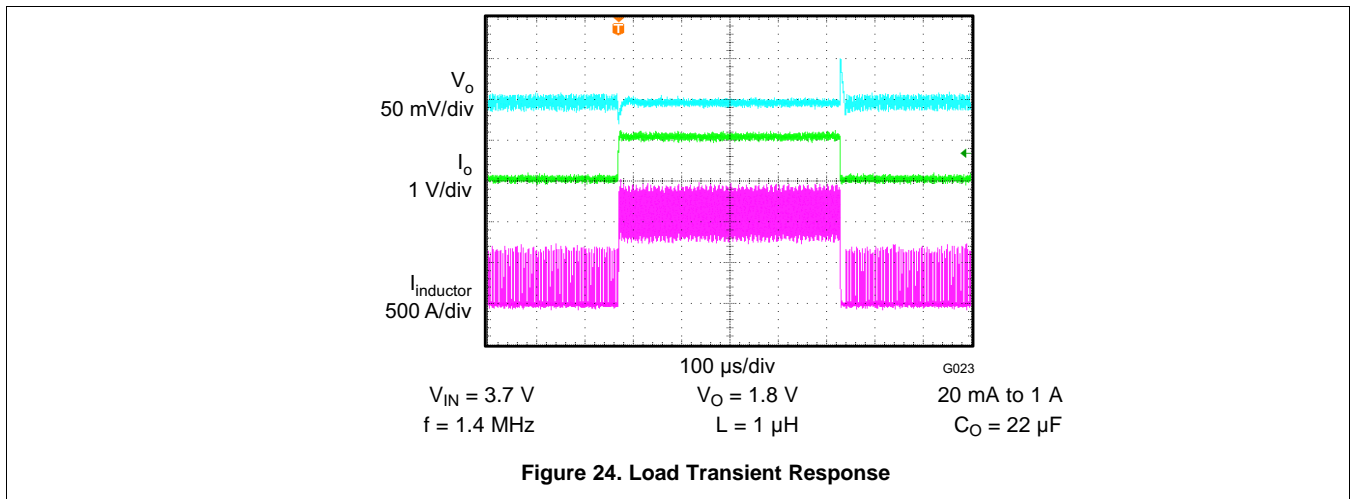

Figure 23. Load Transient Response



9 Power Supply Recommendations

The TLV62090 device has no special requirements for its input power supply. The input power supply's output current needs to be rated according to the supply voltage, output voltage and output current of the TLV62090.

10 Layout

10.1 Layout Guideline

- It is recommended to place the input capacitor as close as possible to the IC pins PVIN and PGND.
- The VOS connection is noise sensitive and needs to be routed short and direct to the output terminal of the inductor.
- The exposed thermal pad of the package, analog ground (pin 6) and power ground (pin 14, 15) should have a single point connection at the exposed thermal pad of the package. This minimizes switch node jitter.
- The charge pump capacitor connected to CP and CN should be placed close to the IC to minimize coupling of switching waveforms into other traces and circuits.
- See [Figure 25](#) and the evaluation module User Guide ([SLVU670](#)) for an example of component placement, routing and thermal design.

10.2 Layout Example

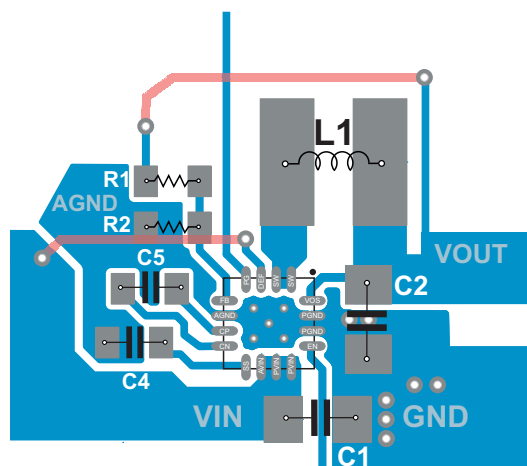

Figure 25. Recommended Layout

11 Device and Documentation Support

11.1 Device Support

11.1.1 Custom Design with WEBENCH® Tools

[Click here](#) to create a custom design using the TLV62090 device with the WEBENCH® Power Designer.

1. Start by entering your V_{IN} , V_{OUT} , and I_{OUT} requirements.
2. Optimize your design for key parameters like efficiency, footprint and cost using the optimizer dial and compare this design with other possible solutions from Texas Instruments.
3. The WEBENCH Power Designer provides you with a customized schematic along with a list of materials with real time pricing and component availability.
4. In most cases, you will also be able to:
 - Run electrical simulations to see important waveforms and circuit performance
 - Run thermal simulations to understand the thermal performance of your board
 - Export your customized schematic and layout into popular CAD formats
 - Print PDF reports for the design, and share your design with colleagues
5. Get more information about WEBENCH tools at www.ti.com/WEBENCH.

11.2 Documentation Support

11.2.1 Third-Party Products Disclaimer

TI'S PUBLICATION OF INFORMATION REGARDING THIRD-PARTY PRODUCTS OR SERVICES DOES NOT CONSTITUTE AN ENDORSEMENT REGARDING THE SUITABILITY OF SUCH PRODUCTS OR SERVICES OR A WARRANTY, REPRESENTATION OR ENDORSEMENT OF SUCH PRODUCTS OR SERVICES, EITHER ALONE OR IN COMBINATION WITH ANY TI PRODUCT OR SERVICE.

11.3 Receiving Notification of Documentation Updates

To receive notification of documentation updates, navigate to the device product folder on ti.com. In the upper right corner, click on *Alert me* to register and receive a weekly digest of any product information that has changed. For change details, review the revision history included in any revised document.

11.4 Community Resources

The following links connect to TI community resources. Linked contents are provided "AS IS" by the respective contributors. They do not constitute TI specifications and do not necessarily reflect TI's views; see TI's [Terms of Use](#).

TI E2E™ Online Community *TI's Engineer-to-Engineer (E2E) Community*. Created to foster collaboration among engineers. At e2e.ti.com, you can ask questions, share knowledge, explore ideas and help solve problems with fellow engineers.

Design Support *TI's Design Support* Quickly find helpful E2E forums along with design support tools and contact information for technical support.

11.5 Trademarks

E2E is a trademark of Texas Instruments.
 WEBENCH is a registered trademark of Texas Instruments.
 is a trademark of ~ Texas Instruments.
 All other trademarks are the property of their respective owners.

11.6 Electrostatic Discharge Caution



These devices have limited built-in ESD protection. The leads should be shorted together or the device placed in conductive foam during storage or handling to prevent electrostatic damage to the MOS gates.

11.7 Glossary

[SLYZ022](#) — *TI Glossary*.

This glossary lists and explains terms, acronyms, and definitions.

12 Mechanical, Packaging, and Orderable Information

The following pages include mechanical, packaging, and orderable information. This information is the most current data available for the designated devices. This data is subject to change without notice and revision of this document. For browser-based versions of this data sheet, refer to the left-hand navigation.

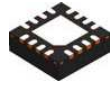

PACKAGE OUTLINE

RGT0016C

VQFN - 1 mm max height

PLASTIC QUAD FLATPACK - NO LEAD

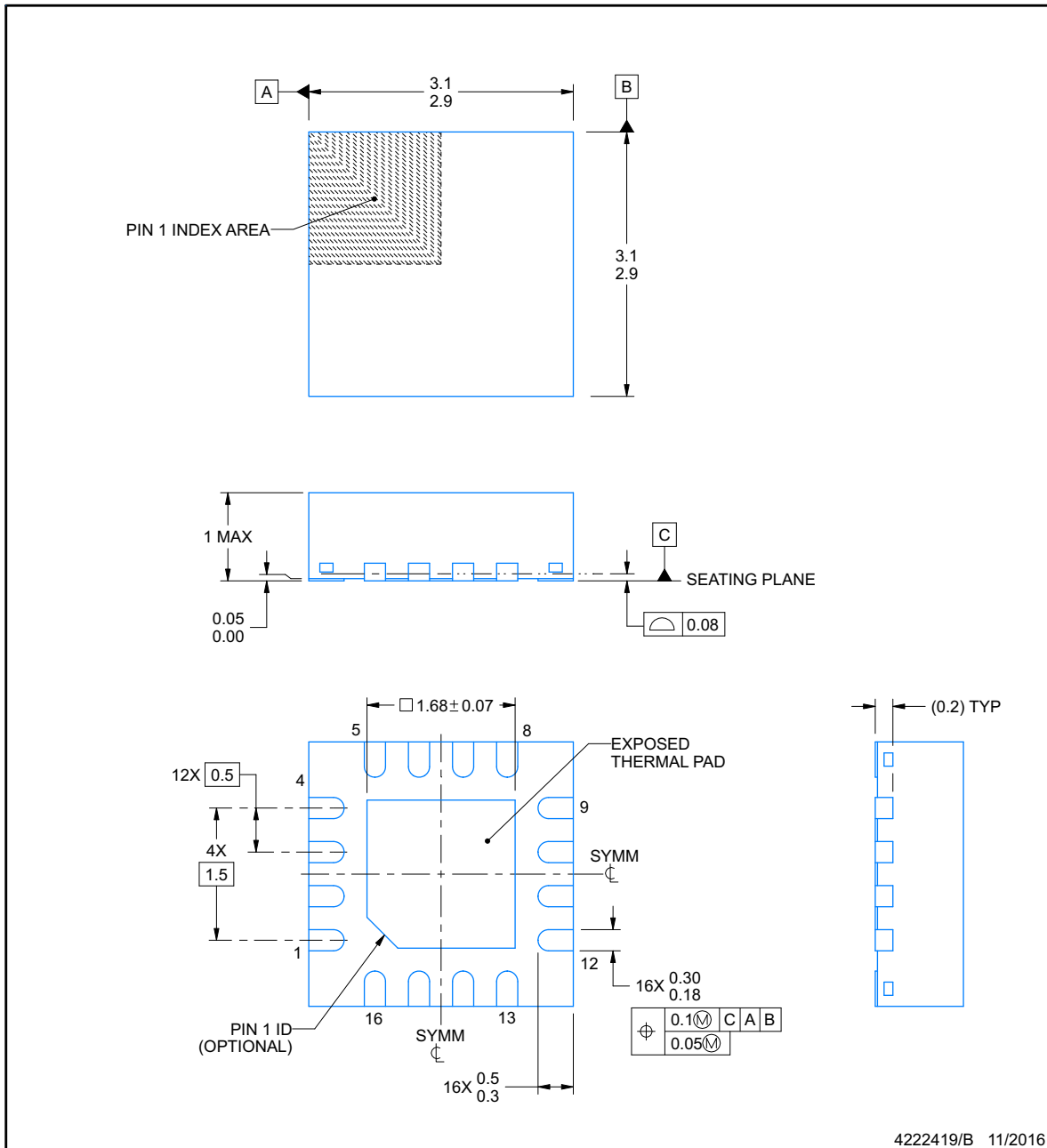

NOTES:

1. All linear dimensions are in millimeters. Any dimensions in parenthesis are for reference only. Dimensioning and tolerancing per ASME Y14.5M.
2. This drawing is subject to change without notice.
3. The package thermal pad must be soldered to the printed circuit board for thermal and mechanical performance.

EXAMPLE STENCIL DESIGN

RGT0016C

VQFN - 1 mm max height

PLASTIC QUAD FLATPACK - NO LEAD

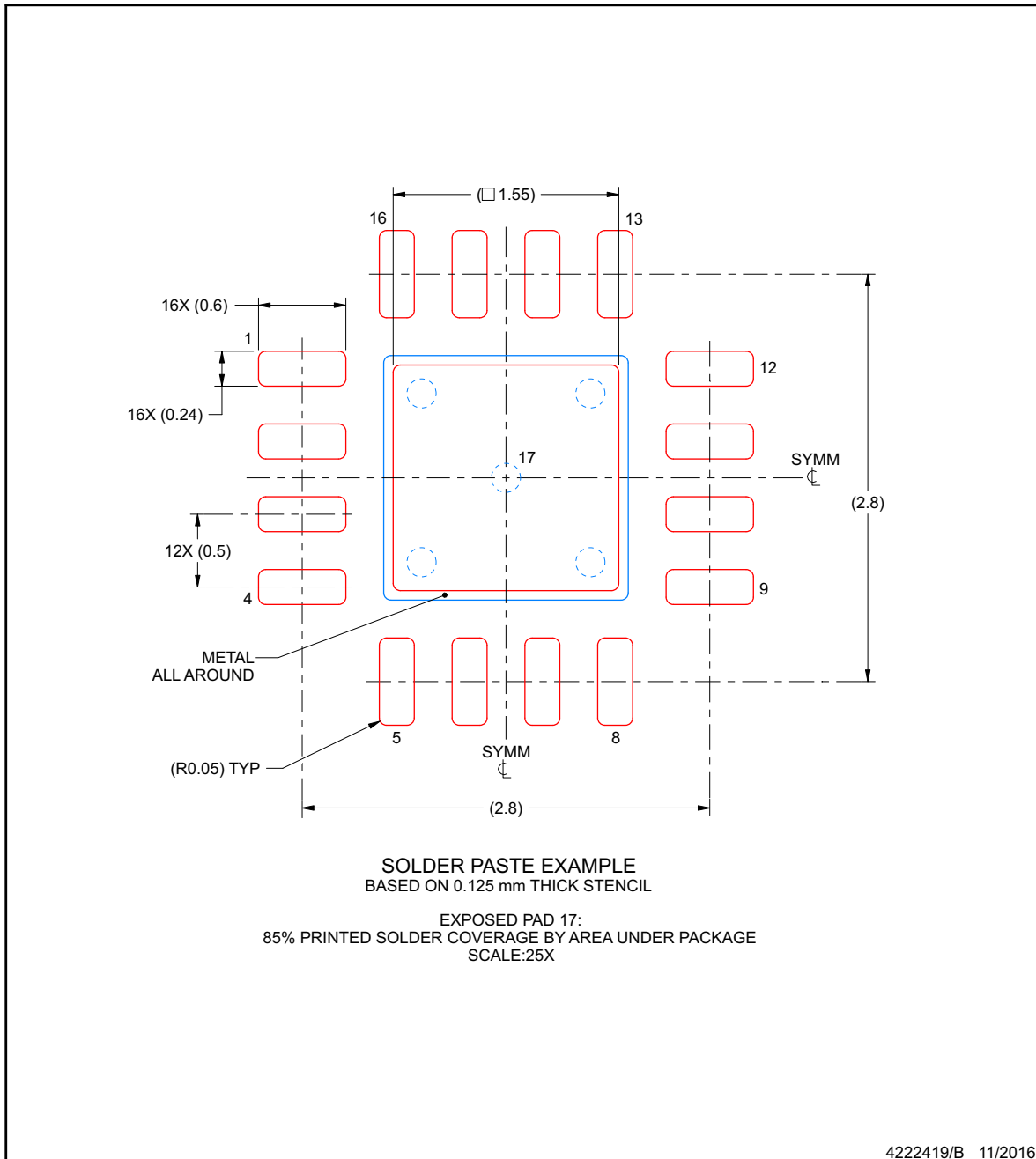

NOTES: (continued)

- 6. Laser cutting apertures with trapezoidal walls and rounded corners may offer better paste release. IPC-7525 may have alternate design recommendations.

PACKAGING INFORMATION

Orderable Device	Status (1)	Package Type	Package Drawing	Pins	Package Qty	Eco Plan (2)	Lead/Ball Finish (6)	MSL Peak Temp (3)	Op Temp (°C)	Device Marking (4/5)	Samples
TLV62090RGTR	ACTIVE	VQFN	RGT	16	3000	Green (RoHS & no Sb/Br)	CU NIPDAU	Level-2-260C-1 YEAR	-40 to 125	SBV	Samples
TLV62090RGTT	ACTIVE	VQFN	RGT	16	250	Green (RoHS & no Sb/Br)	CU NIPDAU	Level-2-260C-1 YEAR	-40 to 125	SBV	Samples

(1) The marketing status values are defined as follows:

ACTIVE: Product device recommended for new designs.

LIFEBUY: TI has announced that the device will be discontinued, and a lifetime-buy period is in effect.

NRND: Not recommended for new designs. Device is in production to support existing customers, but TI does not recommend using this part in a new design.

PREVIEW: Device has been announced but is not in production. Samples may or may not be available.

OBSOLETE: TI has discontinued the production of the device.

(2) **RoHS:** TI defines "RoHS" to mean semiconductor products that are compliant with the current EU RoHS requirements for all 10 RoHS substances, including the requirement that RoHS substance do not exceed 0.1% by weight in homogeneous materials. Where designed to be soldered at high temperatures, "RoHS" products are suitable for use in specified lead-free processes. TI may reference these types of products as "Pb-Free".

RoHS Exempt: TI defines "RoHS Exempt" to mean products that contain lead but are compliant with EU RoHS pursuant to a specific EU RoHS exemption.

Green: TI defines "Green" to mean the content of Chlorine (Cl) and Bromine (Br) based flame retardants meet JS709B low halogen requirements of <=1000ppm threshold. Antimony trioxide based flame retardants must also meet the <=1000ppm threshold requirement.

(3) MSL, Peak Temp. - The Moisture Sensitivity Level rating according to the JEDEC industry standard classifications, and peak solder temperature.

(4) There may be additional marking, which relates to the logo, the lot trace code information, or the environmental category on the device.

(5) Multiple Device Markings will be inside parentheses. Only one Device Marking contained in parentheses and separated by a "-" will appear on a device. If a line is indented then it is a continuation of the previous line and the two combined represent the entire Device Marking for that device.

(6) Lead/Ball Finish - Orderable Devices may have multiple material finish options. Finish options are separated by a vertical ruled line. Lead/Ball Finish values may wrap to two lines if the finish value exceeds the maximum column width.

Important Information and Disclaimer:The information provided on this page represents TI's knowledge and belief as of the date that it is provided. TI bases its knowledge and belief on information provided by third parties, and makes no representation or warranty as to the accuracy of such information. Efforts are underway to better integrate information from third parties. TI has taken and continues to take reasonable steps to provide representative and accurate information but may not have conducted destructive testing or chemical analysis on incoming materials and chemicals. TI and TI suppliers consider certain information to be proprietary, and thus CAS numbers and other limited information may not be available for release.

In no event shall TI's liability arising out of such information exceed the total purchase price of the TI part(s) at issue in this document sold by TI to Customer on an annual basis.

TAPE AND REEL INFORMATION

QUADRANT ASSIGNMENTS FOR PIN 1 ORIENTATION IN TAPE

*All dimensions are nominal

Device	Package Type	Package Drawing	Pins	SPQ	Reel Diameter (mm)	Reel Width W1 (mm)	A0 (mm)	B0 (mm)	K0 (mm)	P1 (mm)	W (mm)	Pin1 Quadrant
TLV62090RGTR	VQFN	RGT	16	3000	330.0	12.4	3.3	3.3	1.1	8.0	12.0	Q2
TLV62090RGTR	VQFN	RGT	16	3000	330.0	12.4	3.3	3.3	1.1	8.0	12.0	Q2
TLV62090RGTT	VQFN	RGT	16	250	180.0	12.5	3.3	3.3	1.1	8.0	12.0	Q2

TAPE AND REEL BOX DIMENSIONS

*All dimensions are nominal

Device	Package Type	Package Drawing	Pins	SPQ	Length (mm)	Width (mm)	Height (mm)
TLV62090RGTR	VQFN	RGT	16	3000	367.0	367.0	35.0
TLV62090RGTR	VQFN	RGT	16	3000	338.0	355.0	50.0
TLV62090RGTT	VQFN	RGT	16	250	338.0	355.0	50.0

IMPORTANT NOTICE

Texas Instruments Incorporated (TI) reserves the right to make corrections, enhancements, improvements and other changes to its semiconductor products and services per JESD46, latest issue, and to discontinue any product or service per JESD48, latest issue. Buyers should obtain the latest relevant information before placing orders and should verify that such information is current and complete.

TI's published terms of sale for semiconductor products (<http://www.ti.com/sc/docs/stdterms.htm>) apply to the sale of packaged integrated circuit products that TI has qualified and released to market. Additional terms may apply to the use or sale of other types of TI products and services.

Reproduction of significant portions of TI information in TI data sheets is permissible only if reproduction is without alteration and is accompanied by all associated warranties, conditions, limitations, and notices. TI is not responsible or liable for such reproduced documentation. Information of third parties may be subject to additional restrictions. Resale of TI products or services with statements different from or beyond the parameters stated by TI for that product or service voids all express and any implied warranties for the associated TI product or service and is an unfair and deceptive business practice. TI is not responsible or liable for any such statements.

Buyers and others who are developing systems that incorporate TI products (collectively, "Designers") understand and agree that Designers remain responsible for using their independent analysis, evaluation and judgment in designing their applications and that Designers have full and exclusive responsibility to assure the safety of Designers' applications and compliance of their applications (and of all TI products used in or for Designers' applications) with all applicable regulations, laws and other applicable requirements. Designer represents that, with respect to their applications, Designer has all the necessary expertise to create and implement safeguards that (1) anticipate dangerous consequences of failures, (2) monitor failures and their consequences, and (3) lessen the likelihood of failures that might cause harm and take appropriate actions. Designer agrees that prior to using or distributing any applications that include TI products, Designer will thoroughly test such applications and the functionality of such TI products as used in such applications.

TI's provision of technical, application or other design advice, quality characterization, reliability data or other services or information, including, but not limited to, reference designs and materials relating to evaluation modules, (collectively, "TI Resources") are intended to assist designers who are developing applications that incorporate TI products; by downloading, accessing or using TI Resources in any way, Designer (individually or, if Designer is acting on behalf of a company, Designer's company) agrees to use any particular TI Resource solely for this purpose and subject to the terms of this Notice.

TI's provision of TI Resources does not expand or otherwise alter TI's applicable published warranties or warranty disclaimers for TI products, and no additional obligations or liabilities arise from TI providing such TI Resources. TI reserves the right to make corrections, enhancements, improvements and other changes to its TI Resources. TI has not conducted any testing other than that specifically described in the published documentation for a particular TI Resource.

Designer is authorized to use, copy and modify any individual TI Resource only in connection with the development of applications that include the TI product(s) identified in such TI Resource. NO OTHER LICENSE, EXPRESS OR IMPLIED, BY ESTOPPEL OR OTHERWISE TO ANY OTHER TI INTELLECTUAL PROPERTY RIGHT, AND NO LICENSE TO ANY TECHNOLOGY OR INTELLECTUAL PROPERTY RIGHT OF TI OR ANY THIRD PARTY IS GRANTED HEREIN, including but not limited to any patent right, copyright, mask work right, or other intellectual property right relating to any combination, machine, or process in which TI products or services are used. Information regarding or referencing third-party products or services does not constitute a license to use such products or services, or a warranty or endorsement thereof. Use of TI Resources may require a license from a third party under the patents or other intellectual property of the third party, or a license from TI under the patents or other intellectual property of TI.

TI RESOURCES ARE PROVIDED "AS IS" AND WITH ALL FAULTS. TI DISCLAIMS ALL OTHER WARRANTIES OR REPRESENTATIONS, EXPRESS OR IMPLIED, REGARDING RESOURCES OR USE THEREOF, INCLUDING BUT NOT LIMITED TO ACCURACY OR COMPLETENESS, TITLE, ANY EPIDEMIC FAILURE WARRANTY AND ANY IMPLIED WARRANTIES OF MERCHANTABILITY, FITNESS FOR A PARTICULAR PURPOSE, AND NON-INFRINGEMENT OF ANY THIRD PARTY INTELLECTUAL PROPERTY RIGHTS. TI SHALL NOT BE LIABLE FOR AND SHALL NOT DEFEND OR INDEMNIFY DESIGNER AGAINST ANY CLAIM, INCLUDING BUT NOT LIMITED TO ANY INFRINGEMENT CLAIM THAT RELATES TO OR IS BASED ON ANY COMBINATION OF PRODUCTS EVEN IF DESCRIBED IN TI RESOURCES OR OTHERWISE. IN NO EVENT SHALL TI BE LIABLE FOR ANY ACTUAL, DIRECT, SPECIAL, COLLATERAL, INDIRECT, PUNITIVE, INCIDENTAL, CONSEQUENTIAL OR EXEMPLARY DAMAGES IN CONNECTION WITH OR ARISING OUT OF TI RESOURCES OR USE THEREOF, AND REGARDLESS OF WHETHER TI HAS BEEN ADVISED OF THE POSSIBILITY OF SUCH DAMAGES.

Unless TI has explicitly designated an individual product as meeting the requirements of a particular industry standard (e.g., ISO/TS 16949 and ISO 26262), TI is not responsible for any failure to meet such industry standard requirements.

Where TI specifically promotes products as facilitating functional safety or as compliant with industry functional safety standards, such products are intended to help enable customers to design and create their own applications that meet applicable functional safety standards and requirements. Using products in an application does not by itself establish any safety features in the application. Designers must ensure compliance with safety-related requirements and standards applicable to their applications. Designer may not use any TI products in life-critical medical equipment unless authorized officers of the parties have executed a special contract specifically governing such use. Life-critical medical equipment is medical equipment where failure of such equipment would cause serious bodily injury or death (e.g., life support, pacemakers, defibrillators, heart pumps, neurostimulators, and implantables). Such equipment includes, without limitation, all medical devices identified by the U.S. Food and Drug Administration as Class III devices and equivalent classifications outside the U.S.

TI may expressly designate certain products as completing a particular qualification (e.g., Q100, Military Grade, or Enhanced Product). Designers agree that it has the necessary expertise to select the product with the appropriate qualification designation for their applications and that proper product selection is at Designers' own risk. Designers are solely responsible for compliance with all legal and regulatory requirements in connection with such selection.

Designer will fully indemnify TI and its representatives against any damages, costs, losses, and/or liabilities arising out of Designer's non-compliance with the terms and provisions of this Notice.

Looking for pricing, stock, or lifecycle information?

Click below to explore more details on WIN SOURCE:

 [View TLV62090RGTT on WIN SOURCE](#)

 [Texas Instruments](#) Information

Optimize Your Supply Chain with WIN SOURCE Solutions

-  Global Sourcing Solution
-  Obsolete Management
-  Cost Control Management
-  Shortage Management
-  Alternative Solution
-  Excess Inventory Management