

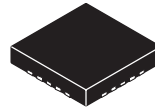

**THE DATASHEET OF  
BQ24007RGWR**

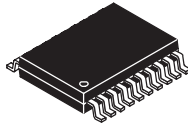



## SINGLE-CELL LI-ION CHARGE MANAGEMENT IC WITH TIMER-ENABLE FOR PDAs AND INTERNET APPLIANCES

### FEATURES

- **Highly Integrated Solution With FET Pass Transistor and Reverse-Blocking Schottky and Thermal Protection**
- **Timer-Enable Function That Allows Host to Disable Charge Timer and Termination When Charge Current Is Shared With a Load or When Battery Is Absent**
- **Integrated Voltage and Current Regulation With Programmable Charge Current**
- **High-Accuracy Voltage Regulation ( $\pm 1\%$ )**
- **Ideal for Low-Dropout Linear Charger Designs for Single-Cell Li-Ion Packs With Coke or Graphite Anodes**
- **Up to 1.2-A Continuous Charge Current**
- **Safety-Charge Timer During Preconditioning and Fast Charge**
- **Integrated Cell Conditioning for Reviving Deeply Discharged Cells and Minimizing Heat Dissipation During Initial Stage of Charge**
- **Optional Temperature or Input-Power Monitoring Before and During Charge**
- **Various Charge-Status Output Options for Driving Single, Double, or Bicolor LEDs or Host-Processor Interface**
- **Charge Termination by Minimum Current and Time**
- **Low-Power Sleep Mode**
- **Packaging: 5 mm  $\times$  5 mm MLP (bq24007) or 20-Lead TSSOP PowerPAD™**

### APPLICATIONS

- **PDAs**
- **Internet Appliances**
- **MP3 Players**
- **Digital Cameras**

### DESCRIPTION

The bq2400x series ICs are advanced Li-Ion linear charge management devices for highly integrated and space-limited applications. They combine high-accuracy current and voltage regulation; FET pass-transistor and reverse-blocking Schottky; battery conditioning, temperature, or input-power monitoring; charge termination; charge-status indication; and charge timer in a small package.

The bq24007 and bq24008 provide the timer-enable function, allowing the host to disable the charge timer when charge current is shared with a load or when the battery is absent. This feature is ideal for applications such as cellular phones, PDAs, and internet appliances.

The bq2400x measures battery temperature using an external thermistor. For safety reasons, the bq2400x inhibits charge until the battery temperature is within the user-defined thresholds. Alternatively, the user can monitor the input voltage to qualify charge. The bq2400x series then charge the battery in three phases: preconditioning, constant current, and constant voltage. If the battery voltage is below the internal low-voltage threshold, the bq2400x uses low-current precharge to condition the battery. A preconditioning timer provides additional safety. Following preconditioning, the bq2400x applies a constant-charge current to the battery. An external sense-resistor sets the magnitude of the current. The constant-current phase is maintained until the battery reaches the charge-regulation voltage. The bq2400x then transitions to the constant voltage phase. The user can configure the device for cells with either coke or graphite anodes. The accuracy of the voltage regulation is better than  $\pm 1\%$  over the operating junction temperature and supply voltage range.

Charge is terminated by maximum time or minimum taper current detection

The bq2400x automatically restarts the charge if the battery voltage falls below an internal recharge threshold.



Please be aware that an important notice concerning availability, standard warranty, and use in critical applications of Texas Instruments semiconductor products and disclaimers thereto appears at the end of this data sheet.

PowerPAD is a trademark of Texas Instruments.



These devices have limited built-in ESD protection. The leads should be shorted together or the device placed in conductive foam during storage or handling to prevent electrostatic damage to the MOS gates.

## ORDERING INFORMATION

T <sub>J</sub>	PACKAGE		CHARGE STATUS CONFIGURATION
	20-LEAD HTTSOP PowerPAD™ (PWP)(1)	20-LEAD 5 mm × 5 mm MLP (RGW)(2)	
-40°C to 125°C	bq24007PWP	bq24007RGW	Single LED
	bq24008PWP	Not available	Single bicolor LED

(1) The PWP package is available taped and reeled. Add R suffix to device type (e.g. bq24007PWPR) to order. Quantities 2500 devices per reel.

(2) The RGW package is available taped and reeled. Add R suffix to device type (e.g. bq24007RGWR) to order. Quantities 3000 devices per reel.

## PACKAGE DISSIPATION RATINGS

PACKAGE	θ <sub>JA</sub>	θ <sub>JC</sub>	T <sub>A</sub> ≤ 25°C POWER RATING	DERATING FACTOR ABOVE T <sub>A</sub> = 25°C
PWP(1)	30.88°C/W	1.19°C/W	3.238 W	0.0324W/°C
RGW(2)	31.41°C/W	1.25°C/W	3.183 W	0.0318W/°C

(1) This data is based on using the JEDEC high-K board and topside traces, top and bottom thermal pad (6,5 × 3,4 mm), internal 1 oz power and ground planes, 8 thermal via underneath the die connecting to ground plane.

(2) This data is based on using the JEDEC high-K board and topside traces, top and bottom thermal pad (3,25 × 3,25 mm), internal 1 oz power and ground planes, 9 thermal via underneath the die connecting to ground plane.

## ABSOLUTE MAXIMUM RATINGS

over operating free-air temperature range unless otherwise noted<sup>(1)</sup>

	<b>bq24007</b> <b>bq24008</b>
Supply voltage (V <sub>CC</sub> with respect to GND)	13.5 V
Input voltage (IN, ISNS, TMR EN, APG/THERM/CR/STAT1/STAT2, VSENSE, TMR SEL, VSEL) (all with respect to GND)	13.5 V
Output current (OUT pins)	2 A
Output sink/source current (STAT1 and STAT2)	10 mA
Operating free-air temperature range, T <sub>A</sub>	-40°C to 70°C
Storage temperature range, T <sub>stg</sub>	-65°C to 150°C
Junction temperature range, T <sub>J</sub>	-40°C to 125°C
Lead temperature (Soldering, 10 s)	300°C

(1) Stresses beyond those listed under “absolute maximum ratings” may cause permanent damage to the device. These are stress ratings only, and functional operation of the device at these or any other conditions beyond those indicated under “recommended operating conditions” is not implied. Exposure to absolute-maximum-rated conditions for extended periods may affect device reliability.

## RECOMMENDED OPERATING CONDITIONS

	MIN	MAX	UNIT
Supply voltage, V <sub>CC</sub>	4.5	10	V
Input voltage, V <sub>IN</sub>	4.5	10	V
Continuous output current		1.2	A
Operating junction temperature range, T <sub>J</sub>	-40	125	°C

## ELECTRICAL CHARACTERISTICS

 over recommended operating junction temperature supply and input voltages, and  $V_I (V_{CC}) \geq V_I (IN)$  ( unless otherwise noted)

PARAMETER	TEST CONDITIONS	MIN	TYP	MAX	UNIT
$V_{CC}$ current	$V_{CC} > V_{CC\_UVLO}$			1	mA
Standby current (sum of currents into OUT and VSENSE pins)	$V_{CC} < V_{CC\_UVLO}$ , $V_{O(OUT)} = 4.3 V$ , $V_{SENSE} = 4.3 V$		2	4	$\mu A$

### VOLTAGE REGULATION, $0^\circ C \leq T_J \leq 125^\circ C$

PARAMETER	TEST CONDITIONS	MIN	TYP	MAX	UNIT
Output voltage	$V_{SEL} = V_{SS}$ , $0 < I_O \leq 1.2 A$	4.059	4.10	4.141	V
	$V_{SEL} = V_{CC}$ , $0 < I_O \leq 1.2 A$	4.158	4.20	4.242	V
Load regulation	$1 mA \leq I_O \leq 1.2 A$ , $V_I(IN) = 5 V$ , $V_{CC} = 5 V$ , $T_J = 25^\circ C$		1		mV
Line regulation	$V_{O(OUT)} + V_{DO} + V_{ilim(MAX)} < V_I(V_{CC}) < 10 V$ , $T_J = 25^\circ C$		0.01		%/V
Dropout voltage = $V_I(IN) - V_{O(OUT)}$	$I_O = 1.0 A$ , $4.9 V < V_I(V_{CC}) < 10 V$			0.7	V
	$I_O = 1.2 A$ , $V_{O(OUT)} + V_{DO} + V_{ilim(MAX)} < V_I(V_{CC}) < 10 V$			0.8	V

### CURRENT REGULATION, $0^\circ C \leq T_J \leq 125^\circ C$

PARAMETER	TEST CONDITIONS	MIN	TYP	MAX	UNIT
Current regulation threshold	$V_{SENSE} < V_O(V_{SEL-LOW/HIGH})$	0.095	0.1	0.105	V
Delay time	$V_{SENSE}$ pulsed above $V_{LOWV}$ to $I_O = 10\%$ of regulated value(1)			1	ms
Rise time	$I_O$ increasing from 10% to 90% of regulated value. $R_{(SNS)} \geq 0.2 \Omega$ , (1)	0.1		1	ms

(1) Specified by design, not production tested.

### CURRENT SENSE RESISTOR, $0^\circ C \leq T_J \leq 125^\circ C$

PARAMETER	TEST CONDITIONS	MIN	TYP	MAX	UNIT
External current sense resistor range ( $R_{(SNS)}$ )	$100 mA \leq I_{lim} \leq 1.2 A$	0.083		1	$\Omega$

### PRECHARGE CURRENT REGULATION, $0^\circ C \leq T_J \leq 125^\circ C$

PARAMETER	TEST CONDITIONS	MIN	TYP	MAX	UNIT
Precharge current regulation	$V_{SENSE} < V_{LOWV}$ , $0.083 \leq R_{(SNS)} \leq 1.0 \Omega$	40	60	80	mA

### $V_{CC}$ UVLO COMPARATOR, $0^\circ C \leq T_J \leq 125^\circ C$

PARAMETER	TEST CONDITIONS	MIN	TYP	MAX	UNIT
Start threshold		4.35	4.43	4.50	V
Stop threshold		4.25	4.33	4.40	V
Hysteresis		50			mV

### APG/THERM COMPARATOR, $0^\circ C \leq T_J \leq 125^\circ C$

PARAMETER	TEST CONDITIONS	MIN	TYP	MAX	UNIT
Upper trip threshold		1.480	1.498	1.515	V
Lower trip threshold		0.545	0.558	0.570	V
Input bias current				1	$\mu A$

### LOWV COMPARATOR, $0^\circ C \leq T_J \leq 125^\circ C$

PARAMETER	TEST CONDITIONS	MIN	TYP	MAX	UNIT
Start threshold		2.80	2.90	3.00	V
Stop threshold		3.00	3.10	3.20	V
Hysteresis		100			mV

## ELECTRICAL CHARACTERISTICS CONTINUED

over recommended operating junction temperature supply and input voltages, and  $V_I (V_{CC}) \geq V_I (IN)$  ( unless otherwise noted)

HIGHV (RECHARGE) COMPARATOR, $0^\circ\text{C} \leq T_J \leq 125^\circ\text{C}$						
PARAMETER	TEST CONDITIONS	MIN	TYP	MAX	UNIT	
Start threshold		3.80	3.90	4.00	V	

OVERV COMPARATOR, $0^\circ\text{C} \leq T_J \leq 125^\circ\text{C}$						
PARAMETER	TEST CONDITIONS	MIN	TYP	MAX	UNIT	
Start threshold		4.35	4.45	4.55	V	
Stop threshold		4.25	4.30	4.35	V	
Hysteresis		50			mV	

TAPERDET COMPARATOR, $0^\circ\text{C} \leq T_J \leq 125^\circ\text{C}$						
PARAMETER	TEST CONDITIONS	MIN	TYP	MAX	UNIT	
Trip threshold		12	18.5	25	mV	

TMR EN LOGIC INPUT, $0^\circ\text{C} \leq T_J \leq 125^\circ\text{C}$						
PARAMETER	TEST CONDITIONS	MIN	TYP	MAX	UNIT	
High-level input voltage		2.25			V	
Low-level input voltage				0.8	V	
Input pull-down resistance		100	200		k $\Omega$	

VSEL LOGIC INPUT, $0^\circ\text{C} \leq T_J \leq 125^\circ\text{C}$						
PARAMETER	TEST CONDITIONS	MIN	TYP	MAX	UNIT	
High-level input voltage		2.25			V	
Low-level input voltage				0.8	V	
Input pull-down resistance		100	200		k $\Omega$	

TMR SEL INPUT $0^\circ\text{C} \leq T_J \leq 125^\circ\text{C}$						
PARAMETER	TEST CONDITIONS	MIN	TYP	MAX	UNIT	
High-level input voltage		2.7			V	
Low-level input voltage				0.6	V	
Input bias current	$V_I(\text{TMR SEL}) \leq 5\text{V}$			15	$\mu\text{A}$	

STAT1, STAT2 (bq24008), $0^\circ\text{C} \leq T_J \leq 125^\circ\text{C}$						
PARAMETER	TEST CONDITIONS	MIN	TYP	MAX	UNIT	
Output (low) saturation voltage	$I_O = 10\text{ mA}$			1.5	V	
Output (low) saturation voltage	$I_O = 4\text{ mA}$			0.6	V	
Output (high) saturation voltage	$I_O = -10\text{ mA}$	$V_{CC}-1.5$			V	
Output (high) saturation voltage	$I_O = -4\text{ mA}$	$V_{CC}-0.5$			V	
Output turn on/off time	$I_O = \pm 10\text{ mA}, C = 100\text{ p}^{(1)}$			100	$\mu\text{s}$	

(1) Specified by design, not production tested.

POWER-ON RESET (POR), $0^\circ\text{C} \leq T_J \leq 125^\circ\text{C}$						
PARAMETER	TEST CONDITIONS	MIN	TYP	MAX	UNIT	
POR delay	See Note 1	1.2	3		ms	
POR falling-edge deglitch	See Note 1	25	75		$\mu\text{s}$	

(1) Specified by design, not production tested.

## ELECTRICAL CHARACTERISTICS CONTINUED

over recommended operating junction temperature supply and input voltages, and  $V_I (V_{CC}) \geq V_I (IN)$  ( unless otherwise noted)

APG/THERM DELAY, $0^\circ\text{C} \leq T_J \leq 125^\circ\text{C}$					
PARAMETER	TEST CONDITIONS	MIN	TYP	MAX	UNIT
APG/THERM falling-edge deglitch	See Note 1	25		75	$\mu\text{s}$

(1) Specified by design, not production tested.

TIMERS, $0^\circ\text{C} \leq T_J \leq 125^\circ\text{C}$					
PARAMETER	TEST CONDITIONS	MIN	TYP	MAX	UNIT
User-selectable timer accuracy	$T_A = 25^\circ\text{C}$	-15%		15%	
		-20%		20%	
Precharge and taper timer			22.5		minute

THERMAL SHUTDOWN, $0^\circ\text{C} \leq T_J \leq 125^\circ\text{C}$					
PARAMETER	TEST CONDITIONS	MIN	TYP	MAX	UNIT
Thermal trip	See Note 1		165		$^\circ\text{C}$
Thermal hysteresis	See Note 1		10		$^\circ\text{C}$

(1) Specified by design, not production tested.

CR PIN, $0^\circ\text{C} \leq T_J \leq 125^\circ\text{C}$					
PARAMETER	TEST CONDITIONS	MIN	TYP	MAX	UNIT
Output voltage	$0 < I_{O(CR)} < 100 \mu\text{A}$ , $C_{(CR)} = 0.22 \mu\text{F}$	2.81	2.85	2.88	V

## PIN ASSIGNMENTS

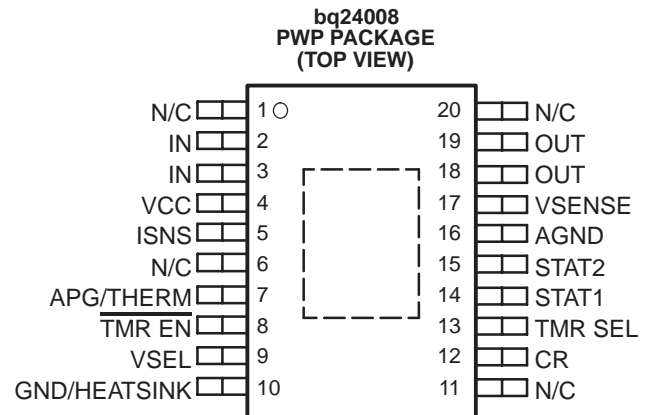
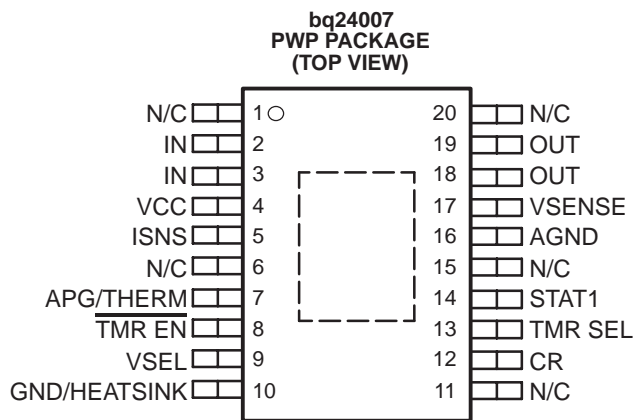

N/C – Do not connect

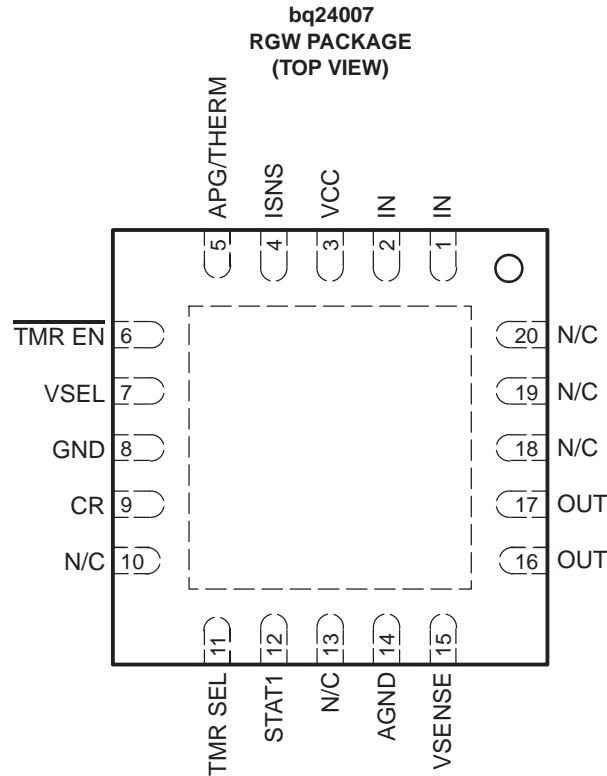

N/C – Do Not Connect

### Terminal Functions

TERMINAL			I/O	DESCRIPTION
NAME	NO.			
	PWP	RGW		
AGND	16	14		Ground pin; connect close to the negative battery terminal.
APG/THERM	7	5	I	Adapter power good input/thermistor sense input
CR	12	9	I	Internal regulator bypass capacitor
TMR EN	8	6	I	Charge-enable input. Active-high enable input with internal pulldown. Low-current stand-by mode active when EN is low.
GND/HEATSINK	10	8		Ground pin; connect to PowerPAD heat-sink layout pattern.
IN	2, 3	1, 2	I	Input voltage. This input provides the charging voltage for the battery.
ISNS	5	4	I	Current sense input
N/C	1, 6, 11, 15, 20	10, 13, 18–20		No connect. These pins must be left floating. Pin 15 is N/C on bq24007PWP only. Pin 13 is N/C on bq24007RGW only.
OUT	18, 19	16, 17	O	Charge current output
STAT1	14	12	O	Status display output 1
STAT2	15	–	O	Status display output 2 (for bq24008 only)
TMR SEL	13	11	I	Charge timer selection input
VCC	4	3	I	Supply voltage
VSEL	9	7	I	4.1-V or 4.2-V charge regulation selection input
VSENSE	17	15	I	Battery voltage sense input

**FUNCTIONAL BLOCK DIAGRAM**

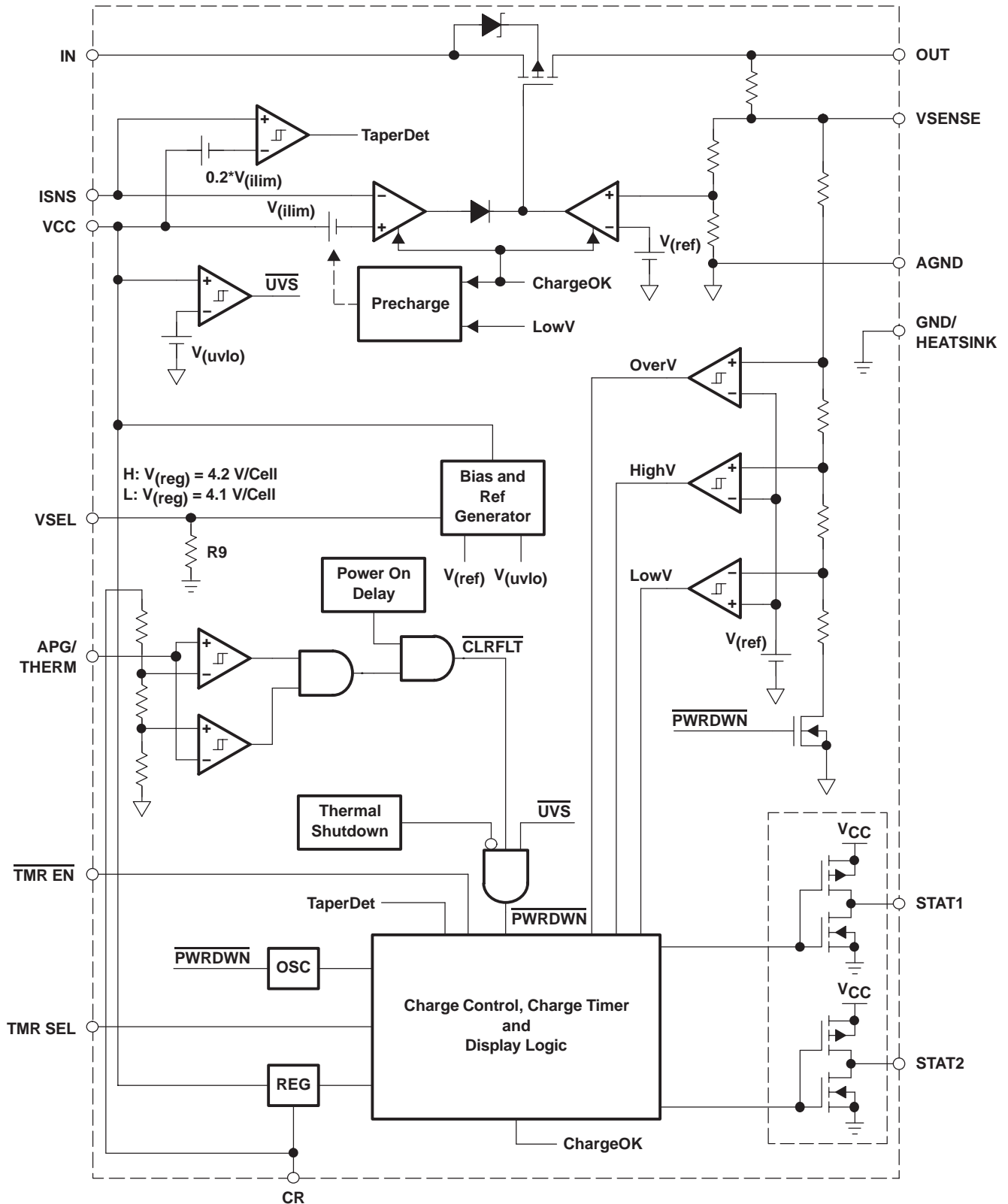

TYPICAL CHARACTERISTICS

OUTPUT VOLTAGE  
vs  
OUTPUT CURRENT

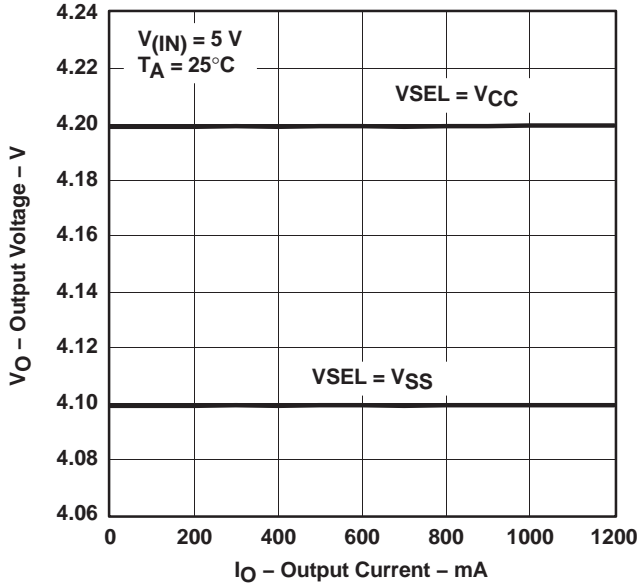

Figure 1

OUTPUT VOLTAGE  
vs  
JUNCTION TEMPERATURE

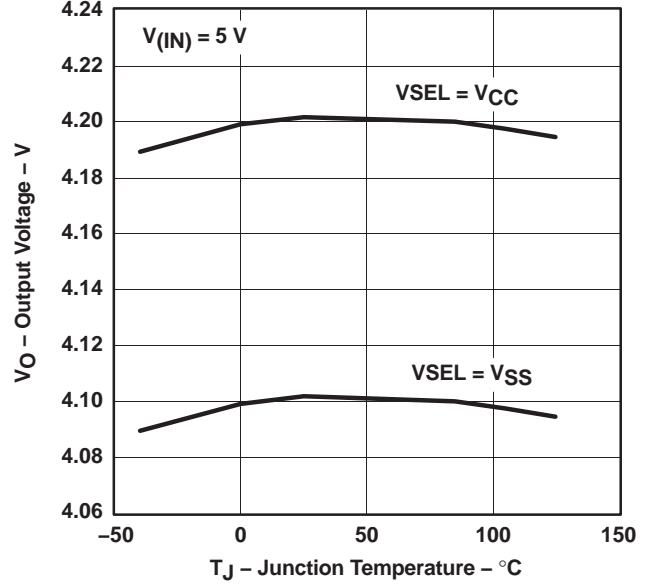

Figure 2

OUTPUT VOLTAGE  
vs  
INPUT VOLTAGE

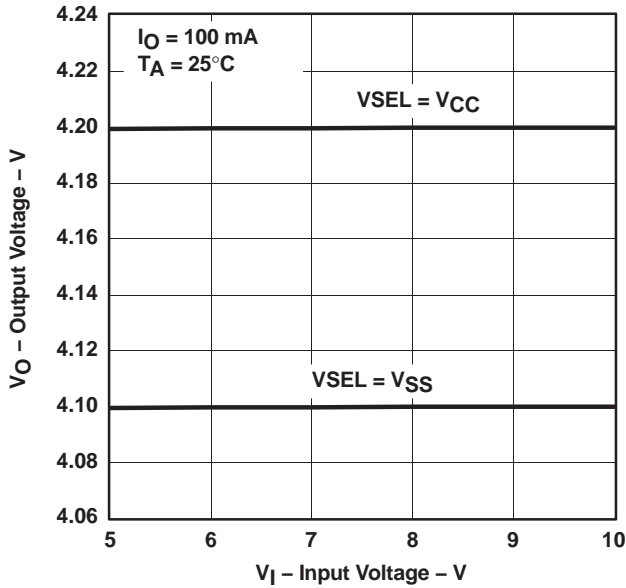

Figure 3

CURRENT SENSE VOLTAGE  
vs  
INPUT VOLTAGE

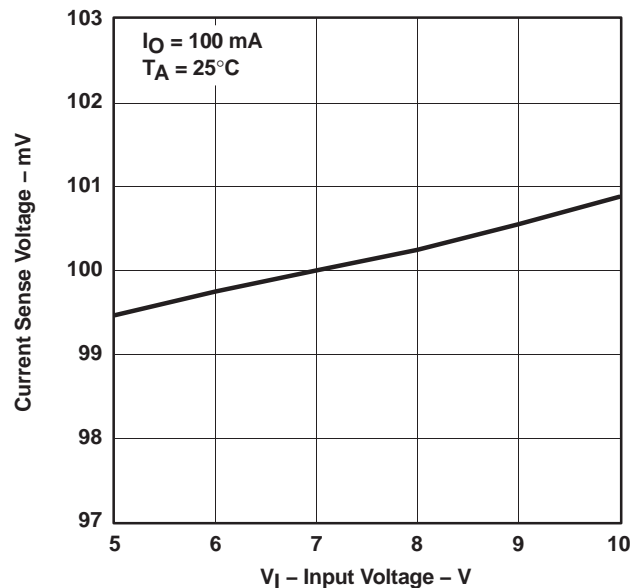

Figure 4

TYPICAL CHARACTERISTICS

CURRENT SENSE VOLTAGE  
vs  
JUNCTION TEMPERATURE

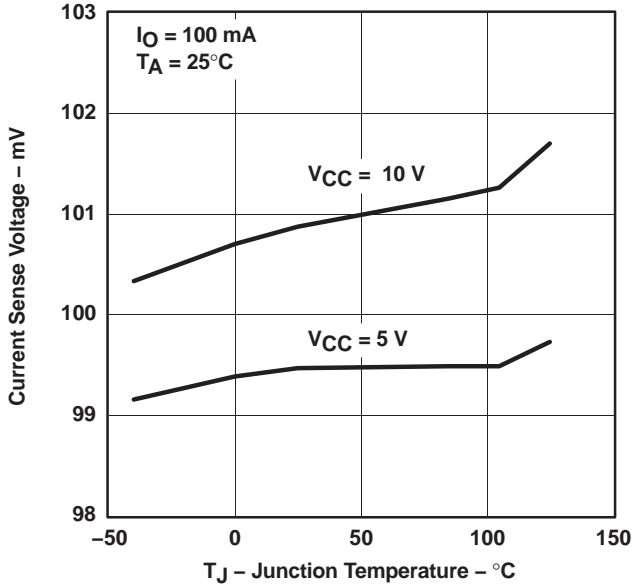

Figure 5

QUIESCENT CURRENT  
vs  
INPUT VOLTAGE

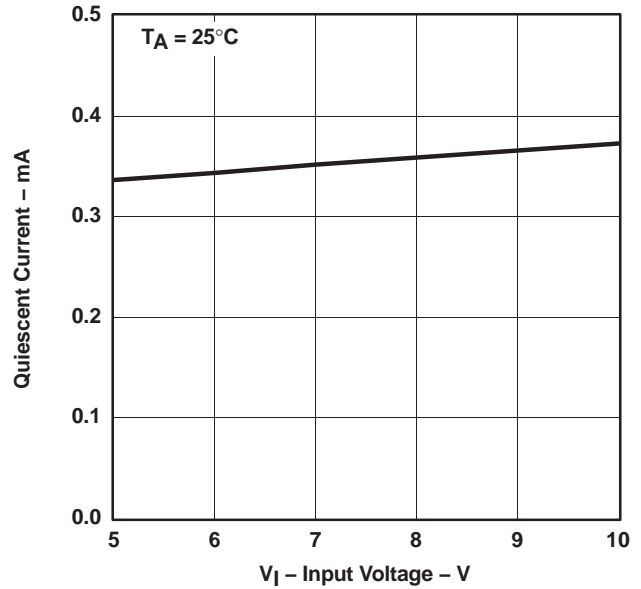

Figure 6

DROPOUT VOLTAGE  
vs  
INPUT VOLTAGE

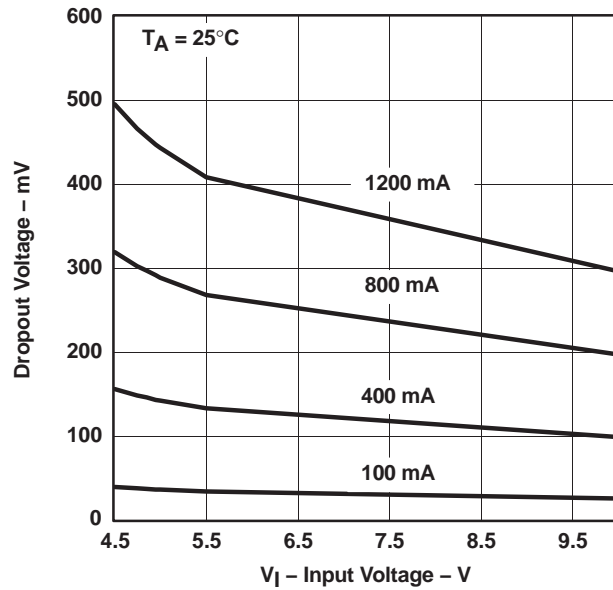

Figure 7

TYPICAL CHARACTERISTICS

DROPOUT VOLTAGE  
vs  
OUTPUT CURRENT

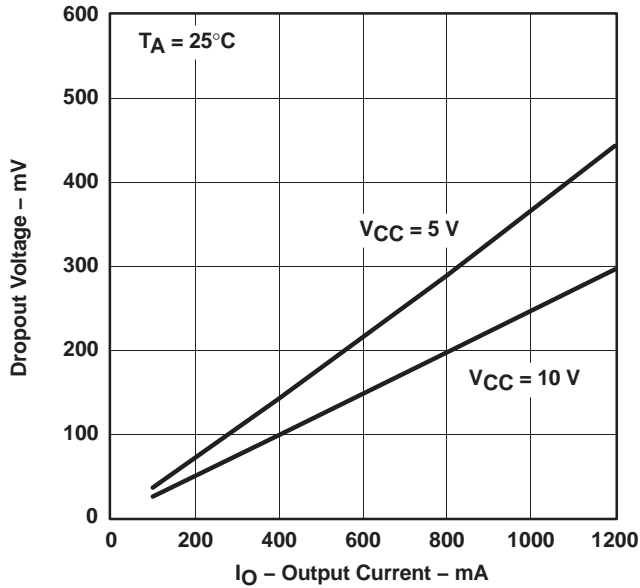

Figure 8

DROPOUT VOLTAGE  
vs  
JUNCTION TEMPERATURE

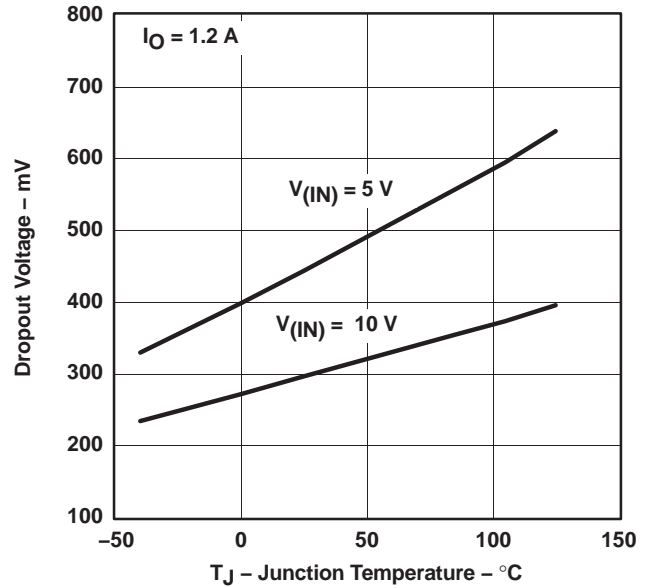

Figure 9

REVERSE CURRENT  
vs  
JUNCTION TEMPERATURE

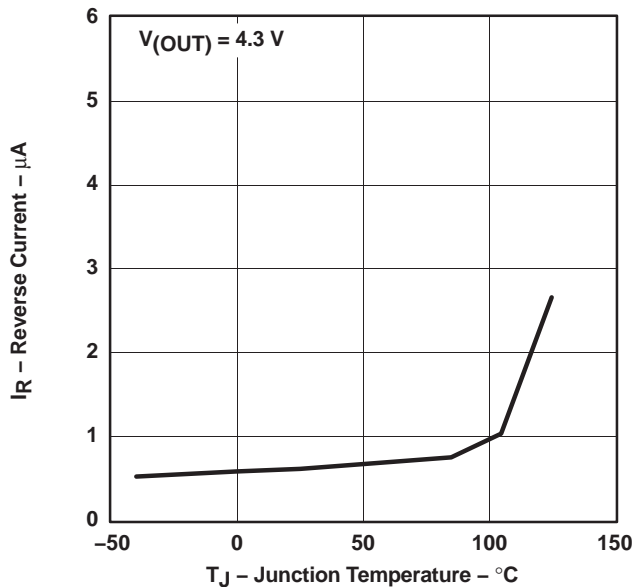

Figure 10

REVERSE CURRENT LEAKAGE  
vs  
VOLTAGE ON OUT PIN

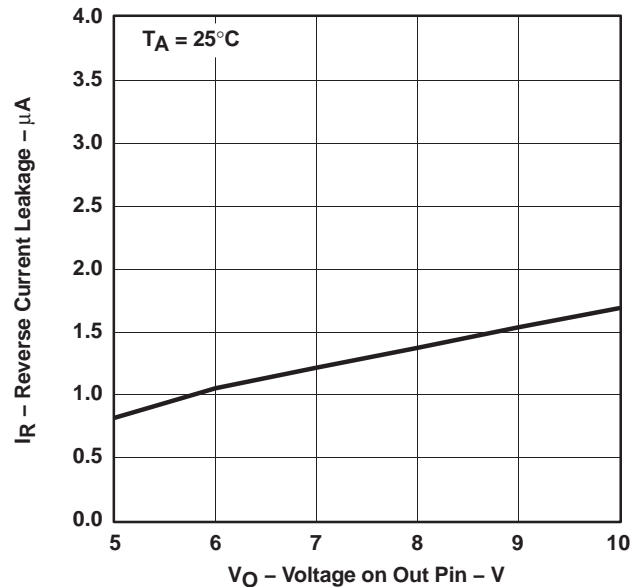

Figure 11

APPLICATION INFORMATION

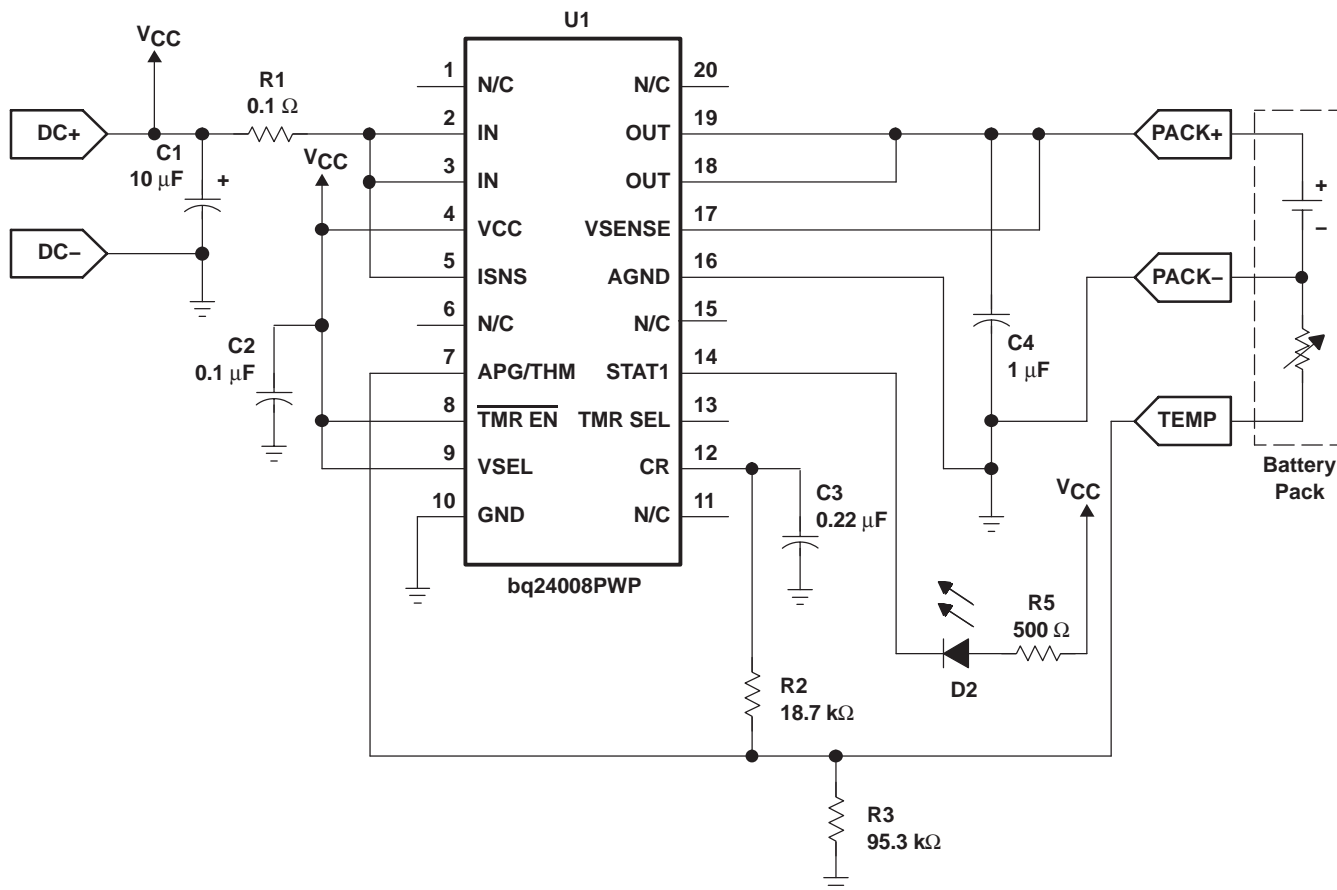

Figure 12. Single-Cell Li-Ion/Li-PoI Charger With Safety Timer Disabled

- If the TMR SEL pin is left floating (3 HR time), a 10-pF capacitor should be installed between TMR SEL and CR.
- If a micro process is monitoring the STAT pins, it may be necessary to add some hysteresis into the feedback to prevent the STAT pins from cycling while crossing the taper detect threshold (usually less than one half second). See SLUU083 EVM or SLUU113 EVM for additional resistors used for the STAT pins.

**APPLICATION INFORMATION**

**FUNCTIONAL DESCRIPTION**

The bq2400x supports a precision current- and voltage-regulated Li-Ion charging system suitable for cells with either coke or graphite anodes. See Figure 13 for a typical charge profile and Figures 14 and 15 for an operational flowchart.

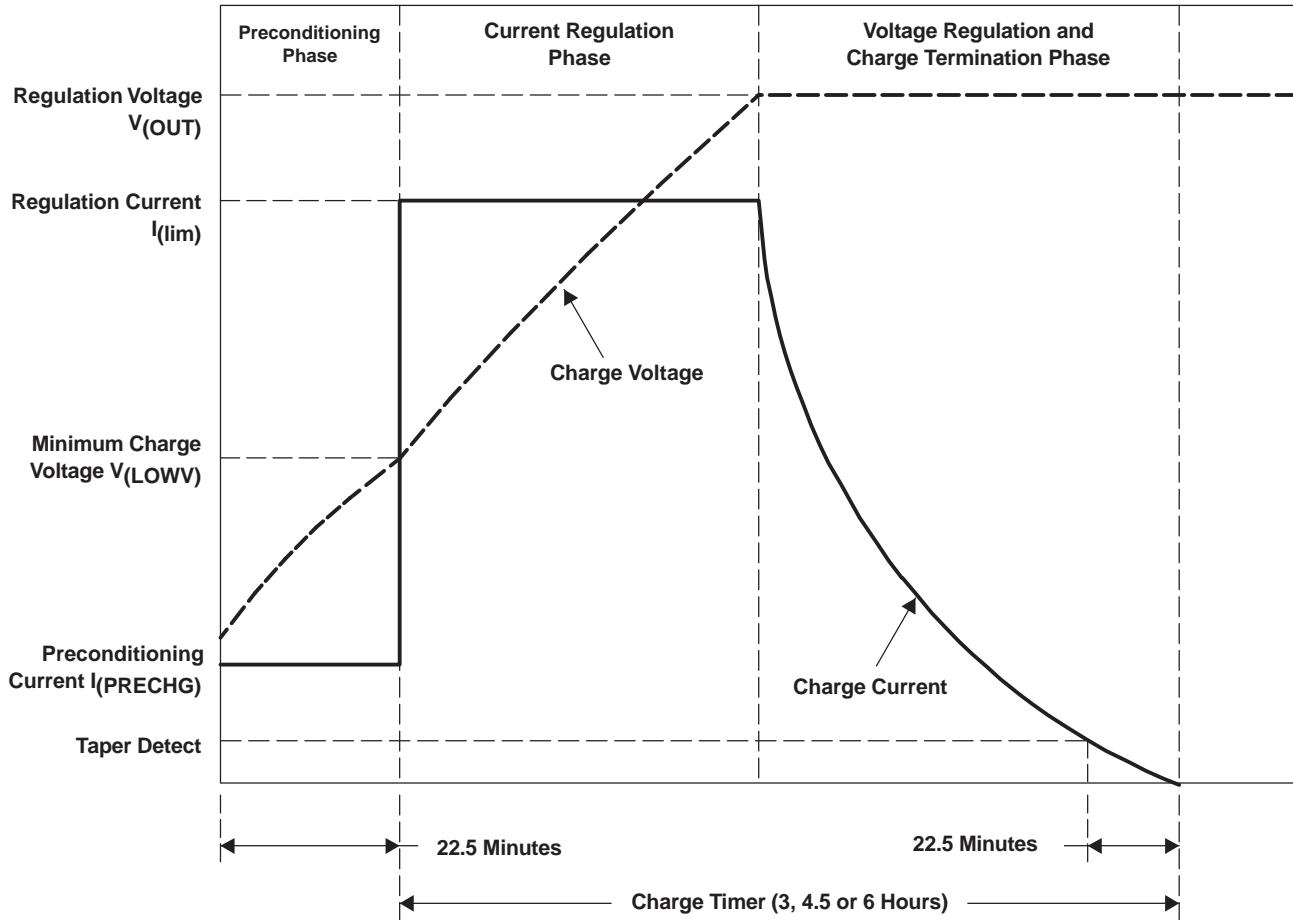

**Figure 13. Typical Charge Profile**



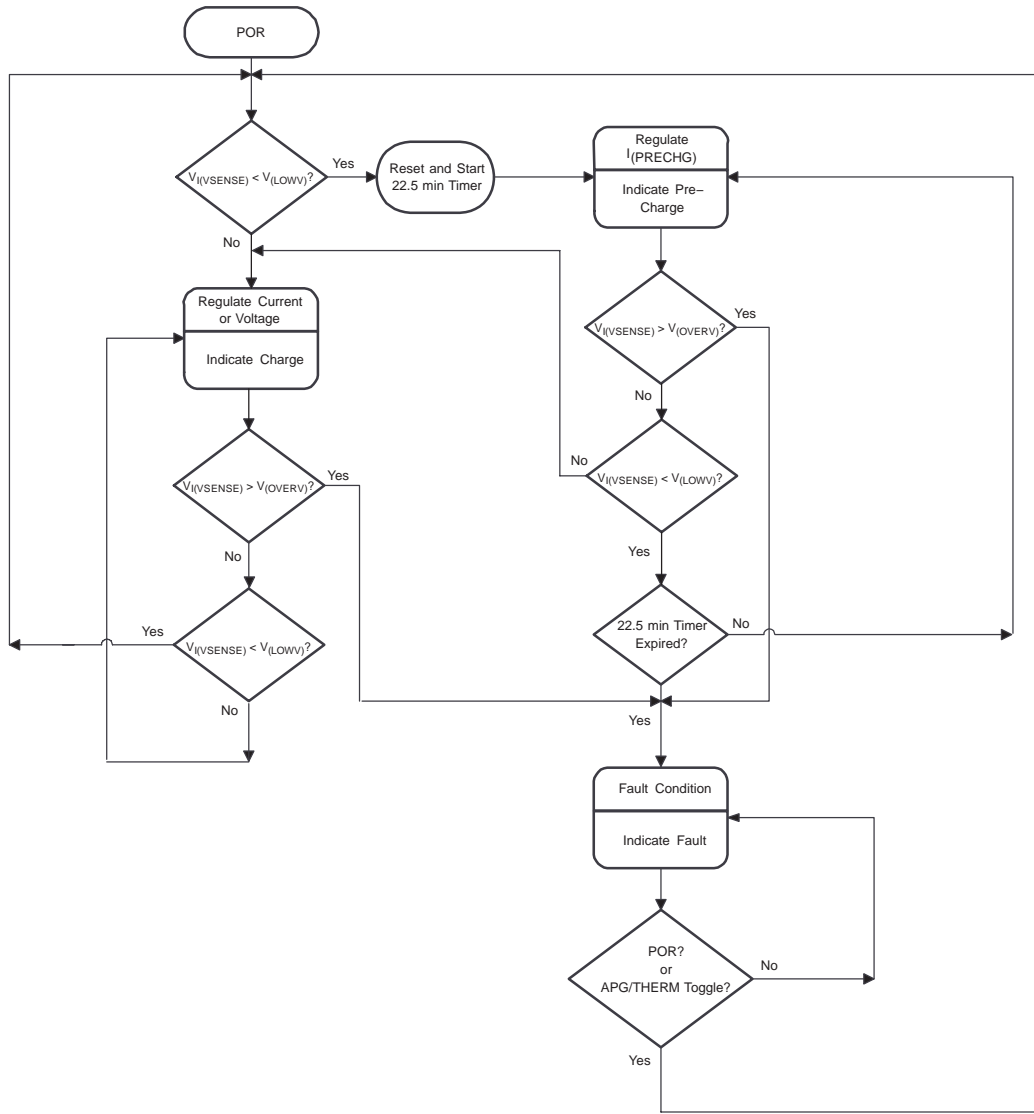

Figure 15. Operational Flow Chart With the Charge Timers Disabled ( $\overline{\text{TMR EN}} = 1$ )

### Charge Qualification and Preconditioning

The bq2400x starts a charge cycle when power is applied while a battery is present. Charge qualification is based on battery voltage and the APG/THERM input.

As shown in the block diagram, the internal LowV comparator output prevents fast-charging a deeply depleted battery. When set, charging current is provided by a dedicated precharge current source. The precharge timer limits the precharge duration. The precharge current also minimizes heat dissipation in the pass element during the initial stage of charge.

The APG/THERM input can also be configured to monitor

either the adapter power or the battery temperature using a thermistor. The bq2400x suspends charge if this input is outside the limits set by the user. Please refer to the APG/THERM input section for additional details.

### Timer Enable Function

The logic  $\overline{\text{TMR EN}}$  enables or disables the charge safety timer. A low-level signal on this pin enables the timer (charge and taper). A high-level input disables the timers and allows the charger to operate continuously. No charge termination is provided when this input is high. Note that the preconditioning timer remains active regardless of the status of this input.

The  $\overline{\text{TMR EN}}$  input can be changed any time during the charge cycle. A low-to-high transition on this pin resets the timers.

### APG/THERM Input

The bq400x continuously monitors temperature or system input voltage by measuring the voltage between the APG/THERM (adapter power good/thermistor) and GND. For temperature, a negative- or a positive- temperature

coefficient thermistor (NTC, PTC) and an external voltage divider typically develop this voltage. (See Figure 16.) The bq2400x compares this voltage against its internal  $V_{TP1}$  and  $V_{TP2}$  thresholds to determine if charging is allowed. (See Figure 17.)

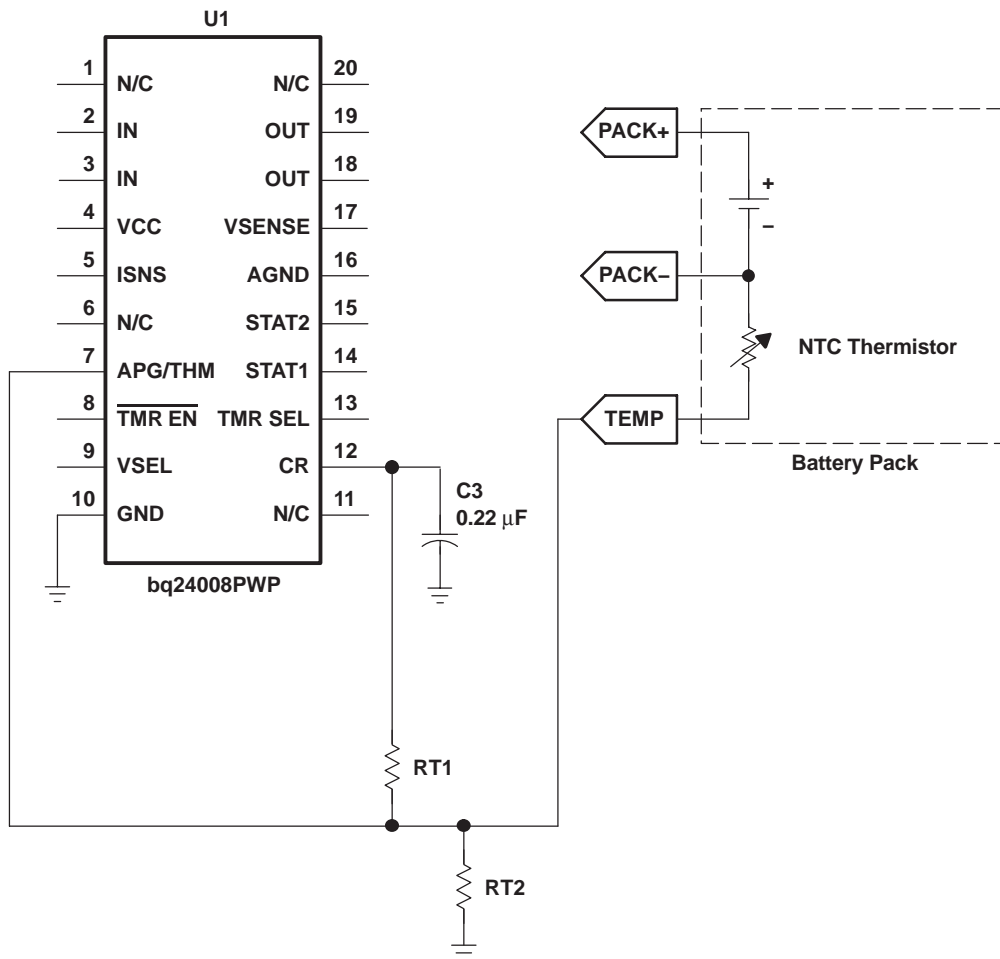

Figure 16. Temperature Sensing Circuit

If the charger designs incorporate a thermistor, the resistor divider RT1 and RT2 is calculated by using the following two equations.

First, calculate RT2.

$$RT2 = \frac{V_B R_H R_C \left[ \frac{1}{V_C} - \frac{1}{V_H} \right]}{R_H \left( \frac{V_B}{V_H} - 1 \right) - R_C \left( \frac{V_B}{V_C} - 1 \right)}$$

then use the resistor value to find RT1.

$$RT1 = \frac{\frac{V_B}{V_C} - 1}{\frac{1}{RT2} + \frac{1}{R_C}}$$

Where:

$$V_B = V_{CR} \text{ (bias voltage)}$$

$R_H$  = Resistance of the thermistor at the desired hot trip threshold

$R_C$  = Resistance of the thermistor at the desired cold trip threshold

$V_H$  = VP2 or the lower APG trip threshold

$V_C$  = VP2 or the upper APG trip threshold

RT1 = Top resistor in the divider string

RT2 = Bottom resistor in the divider string

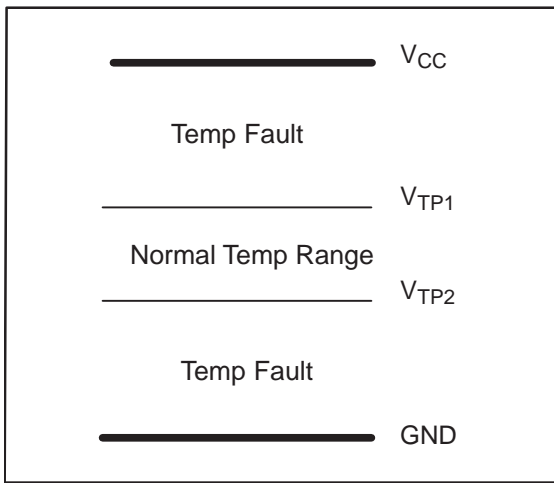

**Figure 17. Temperature Threshold**

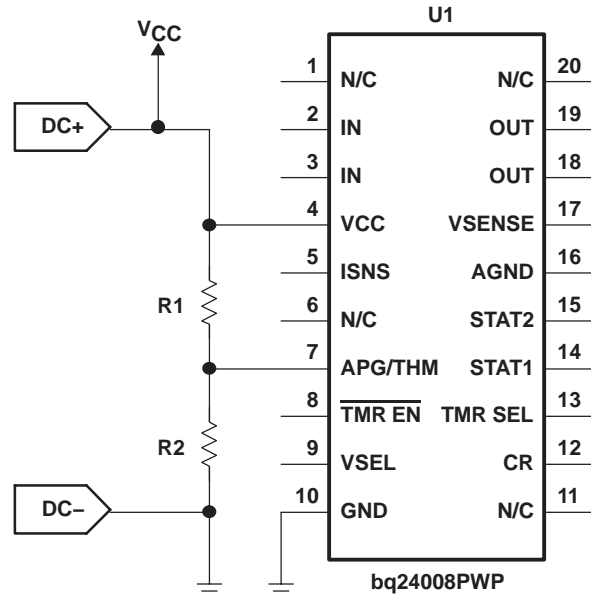

**Figure 18. APG Sensing Circuit**

Values of resistors R1 and R2 can be calculated using the following equation:

$$V_{(APG)} = V_{CC} \frac{R2}{(R1 + R2)}$$

where  $V_{(APG)}$  is the voltage at the APG/THM pin.

**Current Regulation**

The bq2400x provides current regulation while the battery-pack voltage is less than the regulation voltage. The current regulation loop effectively amplifies the error between a reference signal,  $V_{lim}$ , and the drop across the external sense resistor,  $R_{SNS}$ .

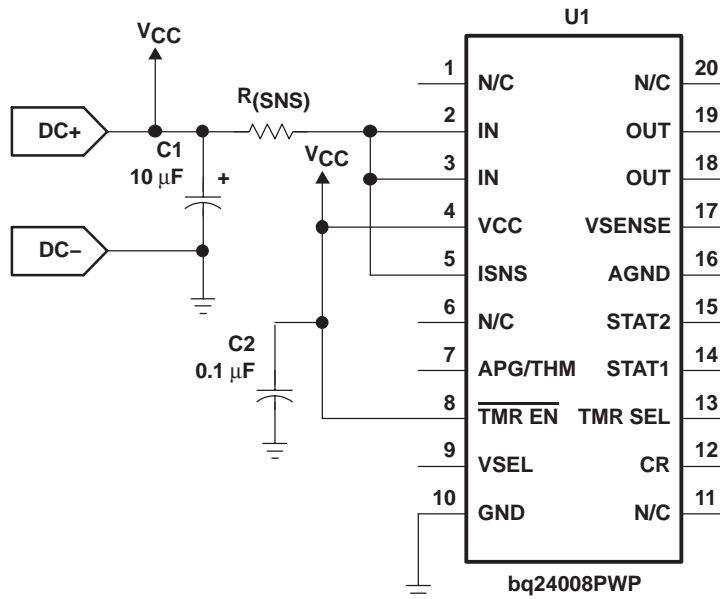

**Figure 19. Current Sensing Circuit**

Charge current feedback, applied through pin ISNS, maintains regulation around a threshold of  $V_{lim}$ . The following formula calculates the value of the sense resistor:

$$R_{(SNS)} = \frac{V_{(lim)}}{I_{(REG)}}$$

where  $I_{REG}$  is the desired charging current.

### Voltage Monitoring and Regulation

Voltage regulation feedback is through pin VSENSE. This input is tied directly to the positive side of the battery pack. The bq2400x supports cells with either coke (4.1 V) or graphite (4.2 V) anode. Pin VSEL selects the charge regulation voltage.

VSEL State (see Note)	CHARGE REGULATION VOLTAGE
Low	4.1 V
High	4.2 V

NOTE: VSEL should not be left floating.

### Charge Termination

The bq2400x continues with the charge cycle until termination by one of the two possible termination conditions:

**Maximum Charge Time:** The bq2400x sets the maximum charge time through pin TMRSEL. The TMR SEL pin allows the user to select between three different total charge-time timers (3, 4, 5, or 6 hours). The charge timer is initiated after the preconditioning phase of the charge and is reset at the beginning of a new charge cycle. Note that in the case of a fault condition, such as an out-of-range signal on the APG/THERM input or a thermal shutdown, the bq2400x suspends the timer. Charge timers are active only when  $\overline{TMR\ EN}$  input is low.

TMRSEL STATE	CHARGE TIME
Floating <sup>(1)</sup>	3 hours
Low	6 hours
High	4.5 hours

(1) To improve noise immunity, it is recommended that a minimum of 10 pF capacitor be tied to Vss on a floating pin.

**Minimum Current:** The bq2400x monitors the charging current during the voltage regulation phase. The bq2400x initiates a 22-minute timer once the current falls below the taperdet trip threshold. Fast charge is terminated once the 22-minute timer expires.

### Charge Status Display

The two available options allow the user to configure the charge status display for single LED (bq24007) or a bicolor LED (bq24008). The output stage is totem pole for the bq24007 and bq24008. The following tables summarize the operation of the three options:

**Table 1. bq24007 (Single LED)**

CHARGE STATE	STAT1
Precharge	ON (LOW)
Fast charge	ON (LOW)
FAULT	Flashing (1 Hz, 50% duty cycle)
Done (>90%)	OFF (HIGH)
Sleep-mode	OFF (HIGH)
APG/Therm invalid	OFF (HIGH)
Thermal shutdown	OFF (HIGH)
Battery absent	OFF (HIGH)

**Table 2. bq24008 (Single Bicolor LED)**

CHARGE STATE	LED1 (RED)	LED2 (GREEN)	APPARENT COLOR
Precharge	ON (LOW)	OFF (HIGH)	RED
Fast charge	ON (LOW)	OFF (HIGH)	RED
FAULT	ON (LOW)	ON (LOW)	YELLOW
Done (>90%)	OFF (HIGH)	ON (LOW)	GREEN
Sleep-mode	OFF (HIGH)	OFF (HIGH)	OFF
APG/Therm invalid	OFF (HIGH)	OFF (HIGH)	OFF
Thermal shutdown	OFF (HIGH)	OFF (HIGH)	OFF
Battery absent	OFF (HIGH)	OFF (HIGH) <sup>(1)</sup>	OFF <sup>(1)</sup>

(1) If thermistor is used, then the green LED is off.

### Thermal Shutdown

The bq2400x monitors the junction temperature  $T_J$  of the DIE and suspends charging if  $T_J$  exceeds 165°C. Charging resumes when  $T_J$  falls below 155°C.

## DETAILED DESCRIPTION

### POWER FET

The integrated transistor is a P-channel MOSFET. The power FET features a reverse-blocking Schottky diode, which prevents current flow from OUT to IN.

An internal thermal-sense circuit shuts off the power FET when the junction temperature rises to approximately 165°C. Hysteresis is built into the thermal sense circuit. After the device has cooled approximately 10°C, the power FET turns back on. The power FET continues to cycle off and on until the fault is removed.

### CURRENT SENSE

The bq2400x regulates current by sensing, on the ISNS pin, the voltage drop developed across an external sense resistor. The sense resistor must be placed between the supply voltage (Vcc) and the input of the IC (IN pins).

### VOLTAGE SENSE

To achieve maximum voltage regulation accuracy, the bq2400x uses the feedback on the VSENSE pin. Externally, this pin should be connected as close to the battery cell terminals as possible. For additional safety, a 10-kΩ internal pullup resistor is connected between the VSENSE and OUT pins.

### TIMER ENABLE

The logic  $\overline{\text{TMR EN}}$  enables or disables the charge safety timer. A low-level signal on this pin enables the timers. A high-level input disables the timers and allows the charge to operate continuously. No charge termination is provided when this input is high. Note that the preconditioning timer remains active regardless of the status of this input.

## THERMAL INFORMATION

### THERMALLY ENHANCED TSSOP-20

The thermally enhanced PWP package is based on the 20-pin TSSOP, but includes a thermal pad (see Figure 20) to provide an effective thermal contact between the IC and the PWB.

Traditionally, surface mount and power have been mutually exclusive terms. A variety of scaled-down TO220-type packages have leads formed as gull wings to make them applicable for surface-mount applications. These packages, however, suffer from several shortcomings: they do not address the very low profile requirements (<2 mm) of many of today's advanced systems, and they do not offer a pin-count high enough to accommodate increasing integration. On the other hand, traditional low-power surface-mount packages require power-dissipation derating that severely limits the usable range of many high-performance analog circuits.

The PWP package (thermally enhanced TSSOP) combines fine-pitch surface-mount technology with thermal performance comparable to much larger power packages.

The PWP package is designed to optimize the heat transfer to the PWB. Because of the very small size and limited mass of a TSSOP package, thermal enhancement is achieved by improving the thermal conduction paths that remove heat from the component. The thermal pad is formed using a lead-frame design (patent pending) and manufacturing technique to provide the user with direct connection to the heat-generating IC. When this pad is soldered or otherwise coupled to an external heat dissipator, high power dissipation in the ultrathin, fine-pitch, surface-mount package can be reliably achieved.

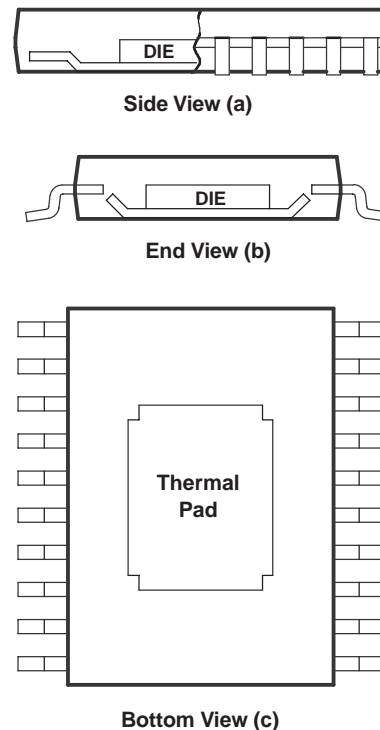

**Figure 20. Views of Thermally Enhanced PWP Package**

Because the conduction path has been enhanced, power-dissipation capability is determined by the thermal considerations in the PWB design. For example, simply adding a localized copper plane (heat-sink surface), which is coupled to the thermal pad, enables the PWP package to dissipate 2.5 W in free air. (Reference Figure 22(a), 8 cm<sup>2</sup> of copper heat sink and natural convection.) Increasing the heat-sink size increases the power dissipation range for the component. The power dissipation limit can be further improved by adding airflow to a PWB/IC assembly. (See Figure 22(b) and 22(c).) The line drawn at 0.3 cm<sup>2</sup> in Figures 21 and 22 indicates performance at the minimum recommended heat-sink size.

### THERMAL INFORMATION

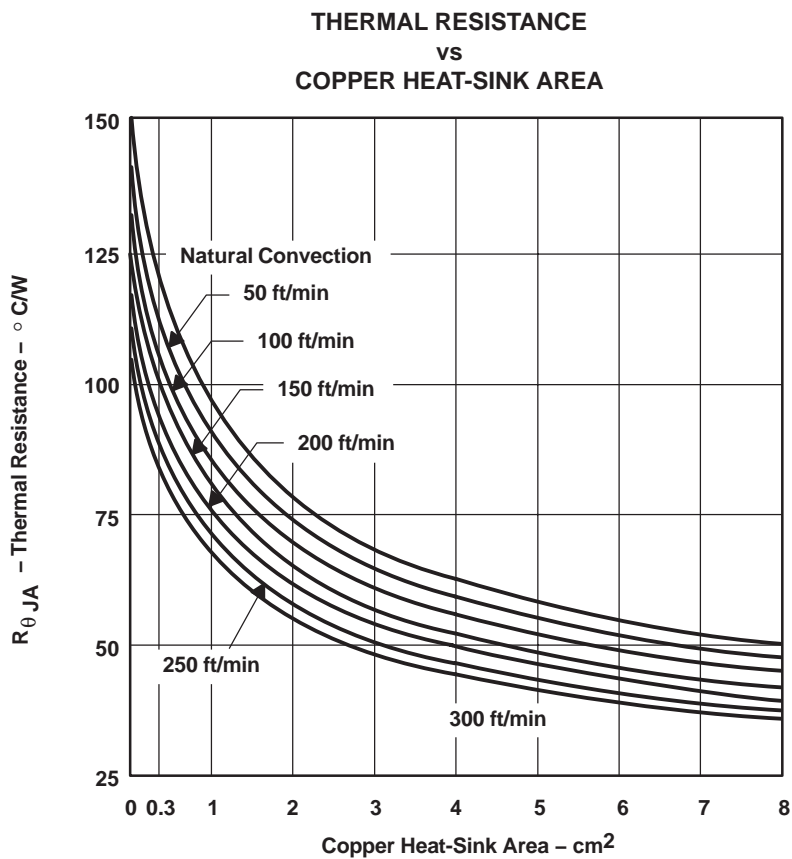
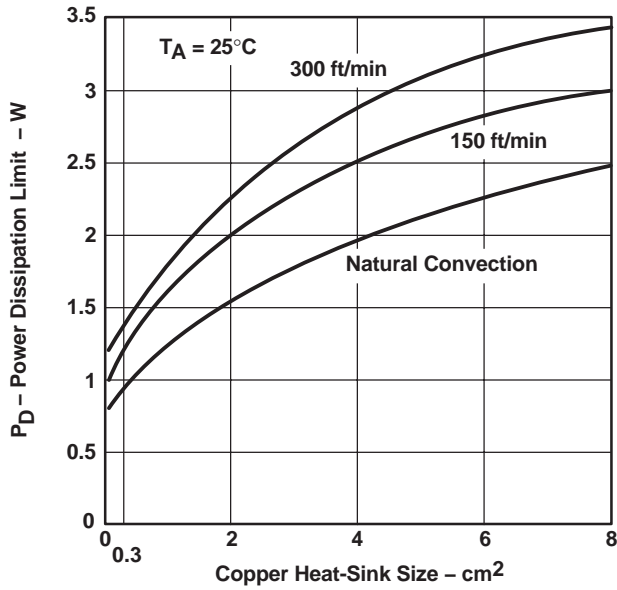
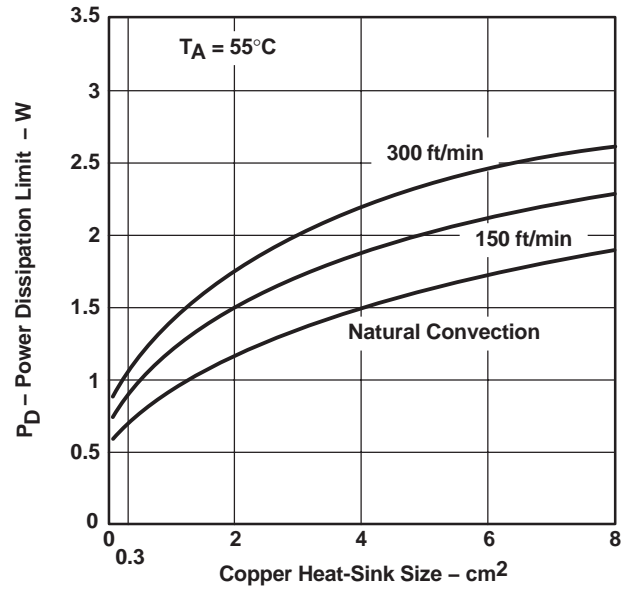

Figure 21

THERMAL INFORMATION



(a)



(b)

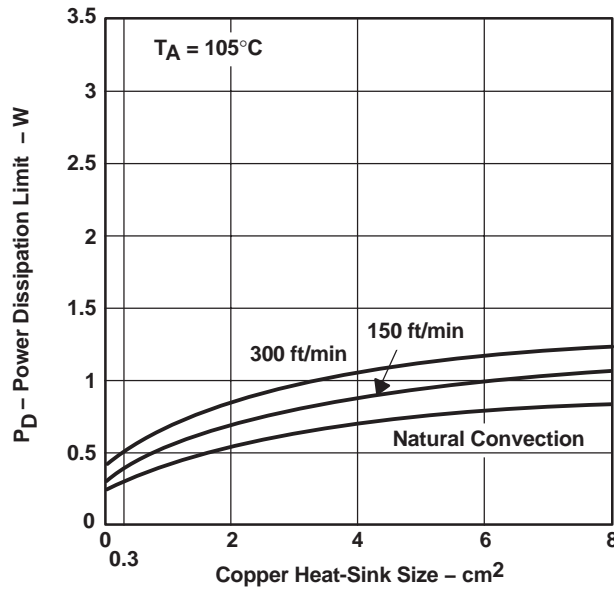

(c)

Figure 22. Power Ratings of the PWP Package at Ambient Temperatures of 25°C, 55°C, and 105°C

## PACKAGING INFORMATION

Orderable Device	Status (1)	Package Type	Package Drawing	Pins	Package Qty	Eco Plan (2)	Lead/Ball Finish (6)	MSL Peak Temp (3)	Op Temp (°C)	Device Marking (4/5)	Samples
BQ24007PWPR	ACTIVE	HTSSOP	PWP	20	2000	Green (RoHS & no Sb/Br)	CU NIPDAU	Level-2-260C-1 YEAR	-20 to 70	BQ24007	<a href="#">Samples</a>
BQ24008PWP	ACTIVE	HTSSOP	PWP	20	70	Green (RoHS & no Sb/Br)	CU NIPDAU	Level-2-260C-1 YEAR	-20 to 70	BQ24008	<a href="#">Samples</a>
BQ24008PWPG4	ACTIVE	HTSSOP	PWP	20	70	Green (RoHS & no Sb/Br)	CU NIPDAU	Level-2-260C-1 YEAR	-20 to 70	BQ24008	<a href="#">Samples</a>
BQ24008PWPR	ACTIVE	HTSSOP	PWP	20	2000	Green (RoHS & no Sb/Br)	CU NIPDAU	Level-2-260C-1 YEAR	-20 to 70	BQ24008	<a href="#">Samples</a>

(1) The marketing status values are defined as follows:

**ACTIVE:** Product device recommended for new designs.

**LIFEBUY:** TI has announced that the device will be discontinued, and a lifetime-buy period is in effect.

**NRND:** Not recommended for new designs. Device is in production to support existing customers, but TI does not recommend using this part in a new design.

**PREVIEW:** Device has been announced but is not in production. Samples may or may not be available.

**OBSELETE:** TI has discontinued the production of the device.

(2) Eco Plan - The planned eco-friendly classification: Pb-Free (RoHS), Pb-Free (RoHS Exempt), or Green (RoHS & no Sb/Br) - please check <http://www.ti.com/productcontent> for the latest availability information and additional product content details.

**TBD:** The Pb-Free/Green conversion plan has not been defined.

**Pb-Free (RoHS):** TI's terms "Lead-Free" or "Pb-Free" mean semiconductor products that are compatible with the current RoHS requirements for all 6 substances, including the requirement that lead not exceed 0.1% by weight in homogeneous materials. Where designed to be soldered at high temperatures, TI Pb-Free products are suitable for use in specified lead-free processes.

**Pb-Free (RoHS Exempt):** This component has a RoHS exemption for either 1) lead-based flip-chip solder bumps used between the die and package, or 2) lead-based die adhesive used between the die and leadframe. The component is otherwise considered Pb-Free (RoHS compatible) as defined above.

**Green (RoHS & no Sb/Br):** TI defines "Green" to mean Pb-Free (RoHS compatible), and free of Bromine (Br) and Antimony (Sb) based flame retardants (Br or Sb do not exceed 0.1% by weight in homogeneous material)

(3) MSL, Peak Temp. - The Moisture Sensitivity Level rating according to the JEDEC industry standard classifications, and peak solder temperature.

(4) There may be additional marking, which relates to the logo, the lot trace code information, or the environmental category on the device.

(5) Multiple Device Markings will be inside parentheses. Only one Device Marking contained in parentheses and separated by a "~" will appear on a device. If a line is indented then it is a continuation of the previous line and the two combined represent the entire Device Marking for that device.

(6) Lead/Ball Finish - Orderable Devices may have multiple material finish options. Finish options are separated by a vertical ruled line. Lead/Ball Finish values may wrap to two lines if the finish value exceeds the maximum column width.

**Important Information and Disclaimer:** The information provided on this page represents TI's knowledge and belief as of the date that it is provided. TI bases its knowledge and belief on information provided by third parties, and makes no representation or warranty as to the accuracy of such information. Efforts are underway to better integrate information from third parties. TI has taken and continues to take reasonable steps to provide representative and accurate information but may not have conducted destructive testing or chemical analysis on incoming materials and chemicals. TI and TI suppliers consider certain information to be proprietary, and thus CAS numbers and other limited information may not be available for release.

In no event shall TI's liability arising out of such information exceed the total purchase price of the TI part(s) at issue in this document sold by TI to Customer on an annual basis.

**TAPE AND REEL INFORMATION**

**QUADRANT ASSIGNMENTS FOR PIN 1 ORIENTATION IN TAPE**

\*All dimensions are nominal

Device	Package Type	Package Drawing	Pins	SPQ	Reel Diameter (mm)	Reel Width W1 (mm)	A0 (mm)	B0 (mm)	K0 (mm)	P1 (mm)	W (mm)	Pin1 Quadrant
BQ24007PWPR	HTSSOP	PWP	20	2000	330.0	16.4	6.95	7.1	1.6	8.0	16.0	Q1
BQ24008PWPR	HTSSOP	PWP	20	2000	330.0	16.4	6.95	7.1	1.6	8.0	16.0	Q1

TAPE AND REEL BOX DIMENSIONS



\*All dimensions are nominal

Device	Package Type	Package Drawing	Pins	SPQ	Length (mm)	Width (mm)	Height (mm)
BQ24007PWPR	HTSSOP	PWP	20	2000	350.0	350.0	43.0
BQ24008PWPR	HTSSOP	PWP	20	2000	350.0	350.0	43.0

# MECHANICAL DATA

PWP (R-PDSO-G20)

PowerPAD™ PLASTIC SMALL OUTLINE

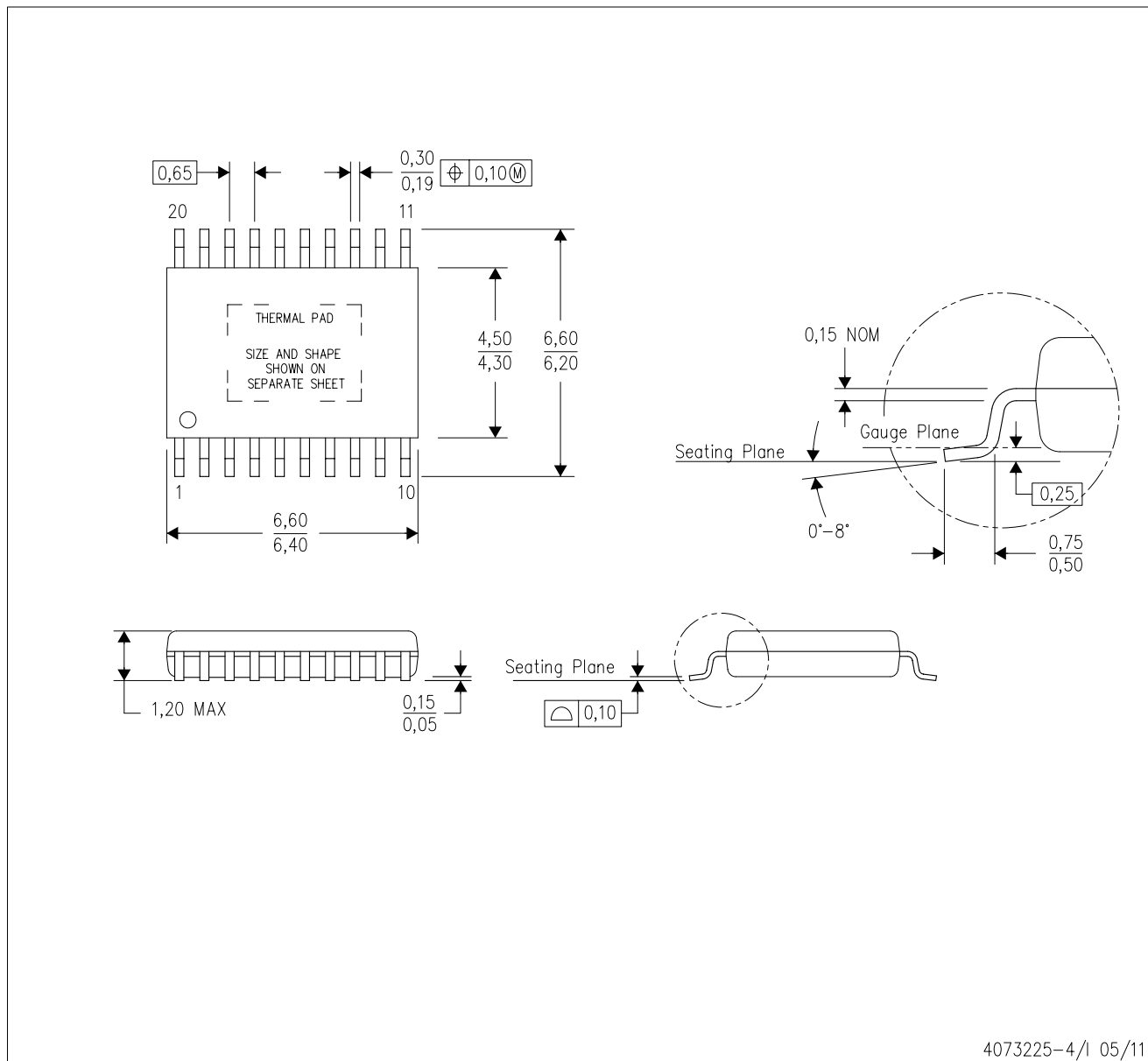

4073225-4/1 05/11

- NOTES:
- All linear dimensions are in millimeters.
  - This drawing is subject to change without notice.
  - Body dimensions do not include mold flash or protrusions. Mold flash and protrusion shall not exceed 0.15 per side.
  - This package is designed to be soldered to a thermal pad on the board. Refer to Technical Brief, PowerPad Thermally Enhanced Package, Texas Instruments Literature No. SLMA002 for information regarding recommended board layout. This document is available at [www.ti.com](http://www.ti.com) <<http://www.ti.com>>.
  - See the additional figure in the Product Data Sheet for details regarding the exposed thermal pad features and dimensions.
  - Falls within JEDEC MO-153

PowerPAD is a trademark of Texas Instruments.

# THERMAL PAD MECHANICAL DATA

## PWP (R-PDSO-G20) PowerPAD™ SMALL PLASTIC OUTLINE

### THERMAL INFORMATION

This PowerPAD™ package incorporates an exposed thermal pad that is designed to be attached to a printed circuit board (PCB). The thermal pad must be soldered directly to the PCB. After soldering, the PCB can be used as a heatsink. In addition, through the use of thermal vias, the thermal pad can be attached directly to the appropriate copper plane shown in the electrical schematic for the device, or alternatively, can be attached to a special heatsink structure designed into the PCB. This design optimizes the heat transfer from the integrated circuit (IC).

For additional information on the PowerPAD package and how to take advantage of its heat dissipating abilities, refer to Technical Brief, PowerPAD Thermally Enhanced Package, Texas Instruments Literature No. SLMA002 and Application Brief, PowerPAD Made Easy, Texas Instruments Literature No. SLMA004. Both documents are available at [www.ti.com](http://www.ti.com).

The exposed thermal pad dimensions for this package are shown in the following illustration.

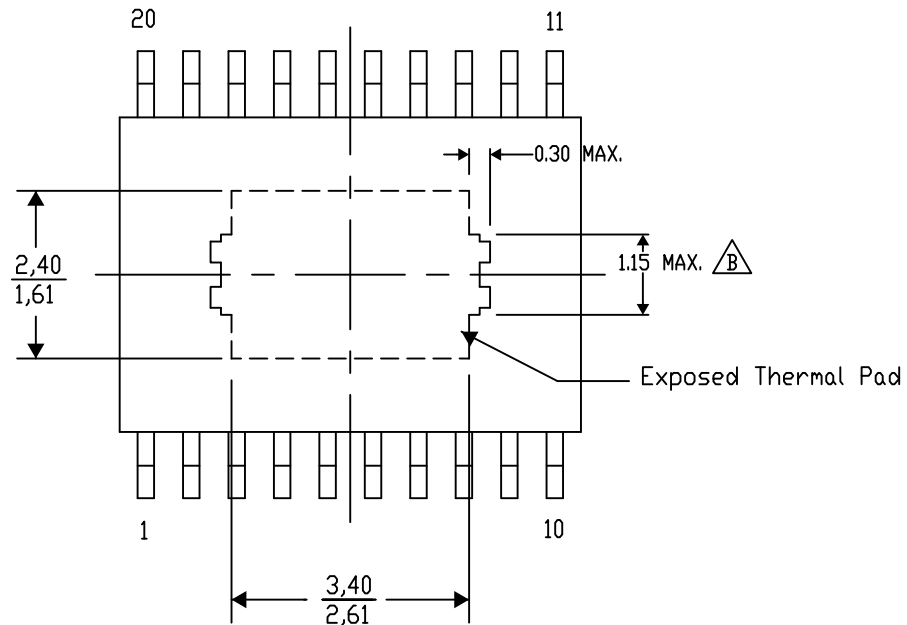

Top View

Exposed Thermal Pad Dimensions

4206332-15/AO 01/16

NOTE: A. All linear dimensions are in millimeters

 Exposed tie strap features may not be present.

PowerPAD is a trademark of Texas Instruments

PWP (R-PDSO-G20)

PowerPAD™ PLASTIC SMALL OUTLINE

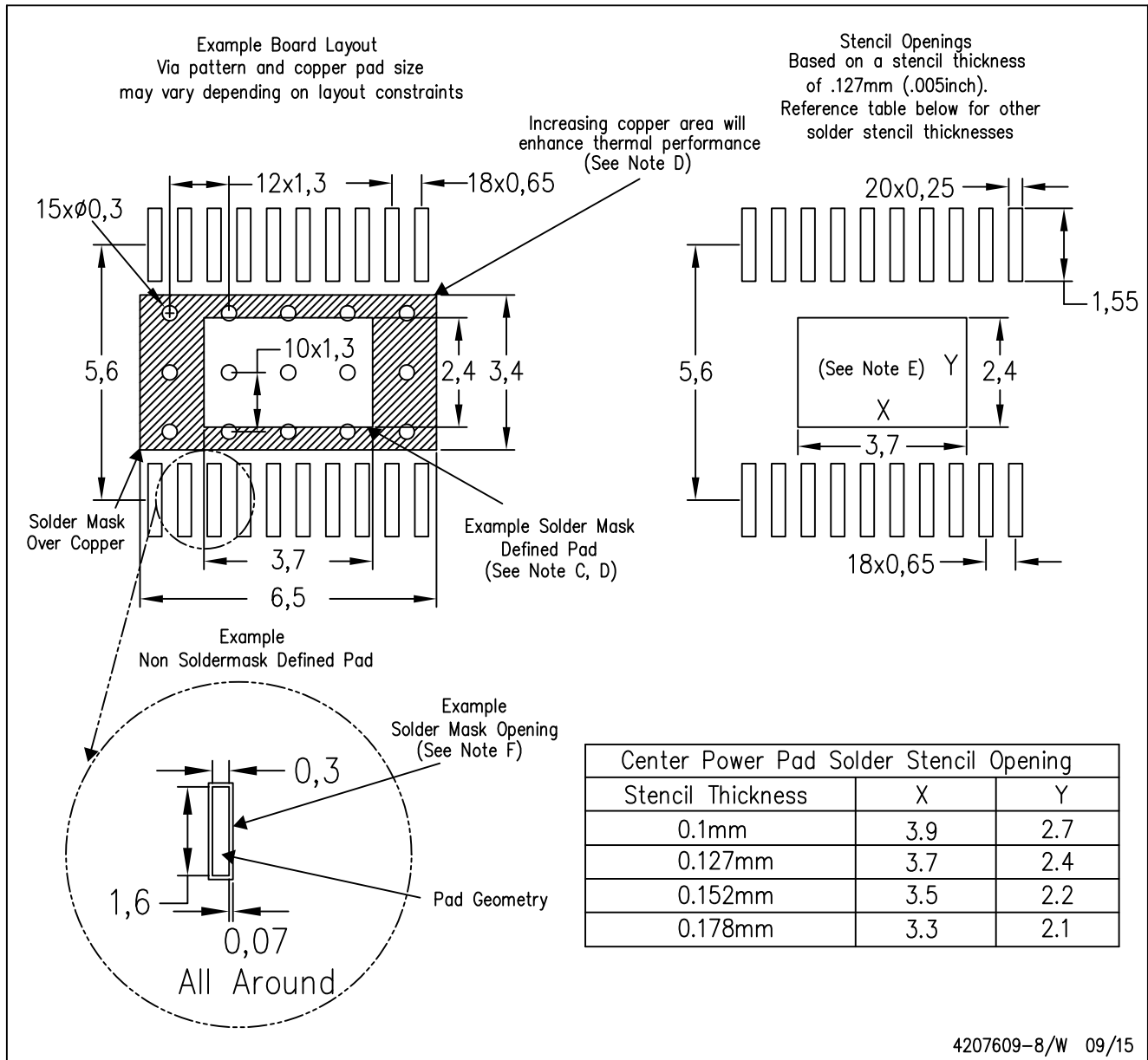

4207609-8/W 09/15

- NOTES:
- A. All linear dimensions are in millimeters.
  - B. This drawing is subject to change without notice.
  - C. Customers should place a note on the circuit board fabrication drawing not to alter the center solder mask defined pad.
  - D. This package is designed to be soldered to a thermal pad on the board. Refer to Technical Brief, PowerPad Thermally Enhanced Package, Texas Instruments Literature No. SLMA002, SLMA004, and also the Product Data Sheets for specific thermal information, via requirements, and recommended board layout. These documents are available at [www.ti.com](http://www.ti.com) <<http://www.ti.com>>. Publication IPC-7351 is recommended for alternate designs.
  - E. Laser cutting apertures with trapezoidal walls and also rounding corners will offer better paste release. Customers should contact their board assembly site for stencil design recommendations. Example stencil design based on a 50% volumetric metal load solder paste. Refer to IPC-7525 for other stencil recommendations.
  - F. Customers should contact their board fabrication site for solder mask tolerances between and around signal pads.

## IMPORTANT NOTICE AND DISCLAIMER

TI PROVIDES TECHNICAL AND RELIABILITY DATA (INCLUDING DATASHEETS), DESIGN RESOURCES (INCLUDING REFERENCE DESIGNS), APPLICATION OR OTHER DESIGN ADVICE, WEB TOOLS, SAFETY INFORMATION, AND OTHER RESOURCES "AS IS" AND WITH ALL FAULTS, AND DISCLAIMS ALL WARRANTIES, EXPRESS AND IMPLIED, INCLUDING WITHOUT LIMITATION ANY IMPLIED WARRANTIES OF MERCHANTABILITY, FITNESS FOR A PARTICULAR PURPOSE OR NON-INFRINGEMENT OF THIRD PARTY INTELLECTUAL PROPERTY RIGHTS.

These resources are intended for skilled developers designing with TI products. You are solely responsible for (1) selecting the appropriate TI products for your application, (2) designing, validating and testing your application, and (3) ensuring your application meets applicable standards, and any other safety, security, or other requirements. These resources are subject to change without notice. TI grants you permission to use these resources only for development of an application that uses the TI products described in the resource. Other reproduction and display of these resources is prohibited. No license is granted to any other TI intellectual property right or to any third party intellectual property right. TI disclaims responsibility for, and you will fully indemnify TI and its representatives against, any claims, damages, costs, losses, and liabilities arising out of your use of these resources.

TI's products are provided subject to TI's Terms of Sale ([www.ti.com/legal/termsofsale.html](http://www.ti.com/legal/termsofsale.html)) or other applicable terms available either on [ti.com](http://ti.com) or provided in conjunction with such TI products. TI's provision of these resources does not expand or otherwise alter TI's applicable warranties or warranty disclaimers for TI products.

Mailing Address: Texas Instruments, Post Office Box 655303, Dallas, Texas 75265  
Copyright © 2019, Texas Instruments Incorporated

## Looking for pricing, stock, or lifecycle information?

Click below to explore more details on WIN SOURCE:

 [View BQ24007RGWR](#) on WIN SOURCE

 [Texas Instruments](#) Information

## Optimize Your Supply Chain with WIN SOURCE Solutions

-  Global Sourcing Solution
-  Obsolete Management
-  Cost Control Management
-  Shortage Management
-  Alternative Solution
-  Excess Inventory Management