



**THE DATASHEET OF  
SG1731J**



## DC MOTOR PULSE WIDTH MODULATOR

### Description

The SG1731 is a pulse width modulator circuit designed specifically for DC motor control. It provides a bi-directional pulse train output in response to the magnitude and polarity of an analog error signal input. The device is useful as the control element in motor-driven servo systems for precision positioning and speed control, as well as in audio modulators and amplifiers using carrier frequencies to 350 kHz.

The circuit contains a triangle waveform oscillator, a wideband operational amplifier for error voltage generation, a summing/scaling network for level-shifting the triangle waveform, externally programmable PWM comparators and dual  $\pm 100$  mA,  $\pm 22$  V totem pole drivers with commutation diodes for full bridge output. A SHUTDOWN terminal forces the drivers into a floating high-impedance state when driven LOW. Supply voltage to the control circuitry and to the output drivers may be from either dual positive and negative supplies, or single-ended.

### Features

- $\pm 3.5$  V to  $\pm 15$  V Control Supply
- $\pm 2.5$  V to  $\pm 22$  V Driver Supply
- Dual 100 mA Source/Sink Output Drivers
- 5 kHz to 350 kHz Oscillator Range
- High Slew Rate Error Amplifier
- Adjustable Deadband Operation
- Digital  $\overline{\text{SHUTDOWN}}$  Input

### High Reliability Features

- Available to MIL-STD-883
- Available to DSCC
  - Standard Microcircuit Drawing (SMD)
- MSC-AMS level "S" Processing Available

### Block Diagram

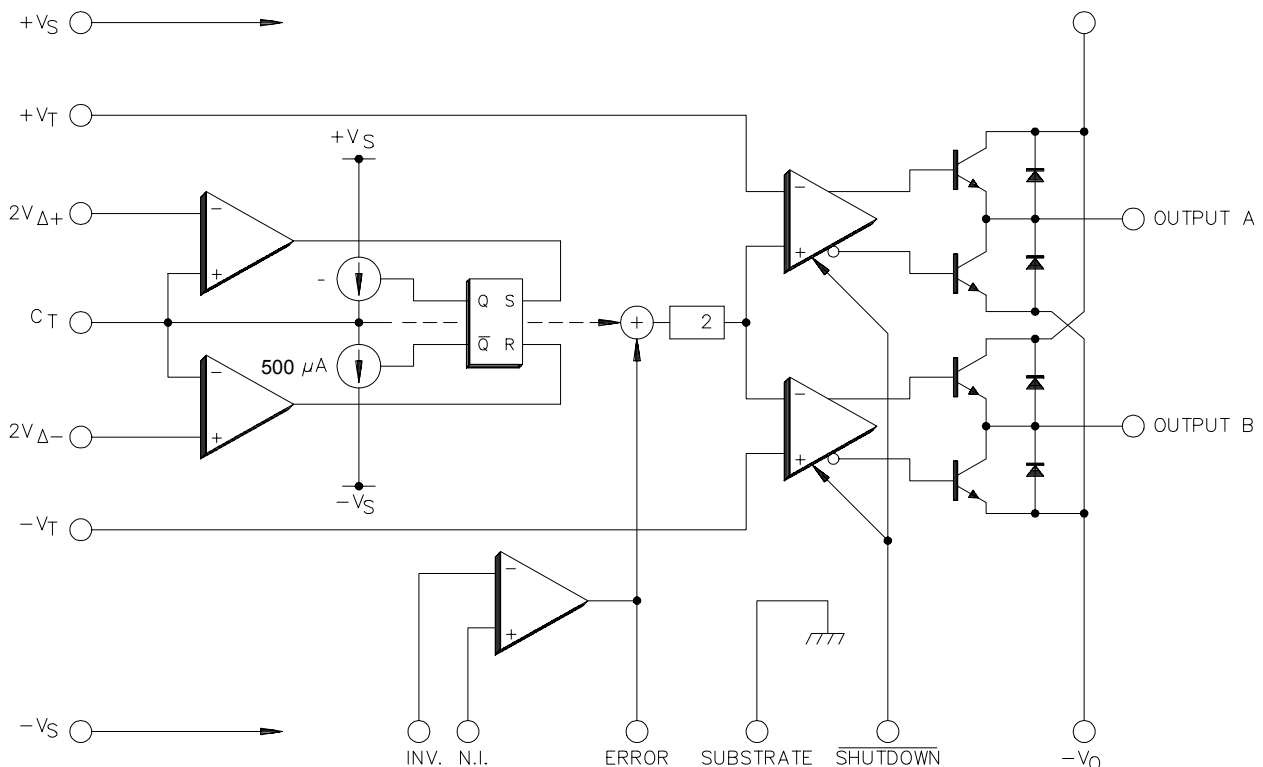

**Figure 1** · Block Diagram

## Absolute Maximum Ratings (Note 1)

Supply Voltage ( $\pm V_S$ ) .....	$\pm 18$ V	Output Driver Diode Current (continuous) .....	200 mA
Analog Inputs .....	$\pm V_S$	Output Driver Diode Current (peak, 500 ns) .....	400 mA
Digital Inputs (SHUTDOWN) .....	$-V_S - 0.3$ V to $-V_S + 18$ V	Operating Junction Temperature	
Output Driver Supply Voltage ( $\pm V_O$ ) .....	$\pm 25$ V	Hermetic (J - Package) .....	150°C
Source/Sink Output Current (continuous) .....	200 mA	Plastic (N - Package) .....	150°C
Source/Sink Output Current (peak, 500 ns) .....	400 mA	Storage Temperature Range .....	-65°C to 150°C
		Lead Temperature (Soldering, 10 Seconds) .....	300°C
		RoHS Peak Package Solder Reflow Temp.(40 sec. max. exp.).....	260°C (+0, -5)

Note 1. Values beyond which damage may occur. Extended operation at the maximum levels may degrade performance and affect reliability.

## Thermal Data

J Package:		
Thermal Resistance-Junction to Case, $\theta_{JC}$ .....	30°C/W	Note A. Junction Temperature Calculation: $T_J = T_A + (P_D \times \theta_{JA})$ .
Thermal Resistance-Junction to Ambient, $\theta_{JA}$ .....	80°C/W	Note B. The above numbers for $\theta_{JC}$ are maximums for the limiting thermal resistance of the package in a standard mounting configuration. The $\theta_{JA}$ numbers are meant to be guidelines for the thermal performance of the device/pc-board system. All of the above assume no ambient airflow.
N Package:		
Thermal Resistance-Junction to Case, $\theta_{JC}$ .....	40°C/W	
Thermal Resistance-Junction to Ambient, $\theta_{JA}$ .....	65°C/W	
L Package:		
Thermal Resistance-Junction to Case, $\theta_{JC}$ .....	35°C/W	
Thermal Resistance-Junction to Ambient, $\theta_{JA}$ .....	120°C/W	

## Recommended Operating Conditions (Note 2)

Supply Voltage Range ( $\pm V_S$ ) .....	$\pm 3.5$ V to $\pm 15$ V	Oscillator Frequency Range .....	10 Hz to 350 kHz
Error Amp Common-Mode Range .....	$-V_S + 3$ V to $V_S - 3$ V	Oscillator Voltage (Peak-to-Peak) .....	1 V to 10 V
Output Driver Supply Voltage Range .....	$\pm 2.5$ V to $\pm 22$ V	Oscillator Timing Capacitor ( $C_T$ ) .....	200 pF to 2.5 $\mu$ F
Source/Sink Output Current (continuous) .....	100 mA	Operating Ambient Temperature Range	
Source/Sink Output Current (peak, 500 ns) .....	200 mA	SG1731 .....	-55°C to 125°C
Output Driver Diode Current (continuous) .....	100 mA	SG2731 .....	-25°C to 85°C
Output Driver Diode Current (peak, 500 ns) .....	200 mA	SG3731 .....	0°C to 70°C

Note 2. Range over which the device is functional and parameter limits are guaranteed.

## Electrical Characteristics

(Unless otherwise specified, these specifications apply over the operating ambient temperatures for SG1731 with  $-55^\circ\text{C} \leq T_A \leq 125^\circ\text{C}$ , SG2731 with  $-25^\circ\text{C} \leq T_A \leq 85^\circ\text{C}$ , SG3731 with  $0^\circ\text{C} \leq T_A \leq 70^\circ\text{C}$ ,  $V_S = \pm 15$  V, and  $V_O = \pm 22$  V. Low duty cycle pulse testing techniques are used which maintains junction and case temperatures equal to the ambient temperature.)

Parameter	Test Conditions	SG1731/2731/3731			Units
		Min.	Typ.	Max.	
<b>Oscillator Section</b>					
$C_T$ Charging Current	$T_A = 25^\circ\text{C}$	450	500	550	$\mu\text{A}$
	$T_A = T_{\text{MIN}}$ to $T_{\text{MAX}}$	400		600	$\mu\text{A}$
$2V_{\Delta\pm}$ Input Bias Current	$V_{\text{CM}} = \pm 5$ V			-20	$\mu\text{A}$
Initial Oscillator Frequency	$C_T = 1000$ pF, $2V_{\Delta\pm} = \pm 5$ V, $T_A = 25^\circ\text{C}$	22.5	25.0	27.5	kHz
Temperature Stability (Note 3)	$C_T = 1000$ pF, $2V_{\Delta\pm} = \pm 5$ V			10	%
<b>Error Amplifier Section (Note 5)</b>					
Input Offset Voltage				10	mV
Input Bias Current				3	$\mu\text{A}$
Input Offset Current				600	nA
Open Loop Voltage Gain	$R_L = 2$ k $\Omega$	70			dB
Output Voltage Swing	$R_L = 2$ k $\Omega$	$\pm 10$			V
Common-Mode Rejection Ratio		70			dB
Slew Rate (Notes 3 and 4)	$T_A = 25^\circ\text{C}$	5	10		V/ $\mu\text{s}$
Unity Gain Bandwidth (Notes 3 and 4)	$T_A = 25^\circ\text{C}$	0.7	1		MHz
<b>PWM Comparators</b>					
Input Bias Current	$\pm V_T = \pm 3$ V			6	$\mu\text{A}$

## Electrical Characteristics (Continued)

Parameter	Test Conditions	SG1731/2731/3731			Units
		Min.	Typ.	Max.	
<b>SHUTDOWN Section</b>					
Logic Threshold	$-V_S = -3.5 \text{ V to } -15 \text{ V}$	$V_S + 0.8$		$V_S + 2.0$	V
SHUTDOWN HIGH Current	$V_{\text{SHUTDOWN}} = -V_S + 2.4 \text{ V}$			400	$\mu\text{A}$
SHUTDOWN LOW Current	$V_{\text{SHUTDOWN}} = -V_S$			-1.0	mA
<b>Output Drivers (Each Output)</b>					
HIGH Output Voltage	$I_{\text{SOURCE}} = 20 \text{ mA}$	19.2			V
	$I_{\text{SOURCE}} = 100 \text{ mA}$	19.0			V
LOW Output Voltage	$I_{\text{SINK}} = 20 \text{ mA}$			-19.2	V
	$I_{\text{SINK}} = 100 \text{ mA}$			-19.0	V
Driver Risettime	$C_L = 1000 \text{ pF}$			300	ns
Driver Falltime	$C_L = 1000 \text{ pF}$			300	ns
<b>Total Supply Current</b>					
$V_S$ Supply Current	$V_{\text{SHUTDOWN}} = -V_S + 0.8 \text{ V}$			14	mA
$V_O$ Supply Current	$V_{\text{SHUTDOWN}} = -V_S + 0.8 \text{ V}$			6	mA

Note 3. These parameters, although guaranteed, are not tested in production.  
 Note 4. Unity Gain Inverting 10 k $\Omega$  Feedback Resistance.

Note 5.  $V_{\text{CM}} = \pm 12 \text{ V}$ .

## Application Information

### SUPPLY VOLTAGE

The SG1731 requires a supply voltage for the control circuitry ( $V_S$ ) and for the power output drivers ( $V_O$ ). Each supply may be either balanced positive and negative with respect to ground, or single-ended. The only restrictions are:

1. The voltage between  $+V_S$  and  $-V_S$  must be at least 7.0 V; but no more than 44 V.
2. The voltage between  $+V_O$  and  $-V_O$  must be at least 5.0 V; but no more than 44 V.
3.  $+V_O$  must be at least 5 V more positive than  $-V_S$ . This eliminates the combination of a single-ended positive control supply with a single-ended negative driver supply.

### SUBSTRATE CONNECTION

The substrate connection (Pin 10) must always be connected to either  $-V_S$  or  $-V_O$ , whichever is more negative. The substrate must also be well bypassed to ground with a high quality capacitor.

### OSCILLATOR

The triangle oscillator consists of two voltage comparators, a set/reset flip-flop, a bi-directional 500  $\mu\text{A}$  current source, and an external timing capacitor  $C_T$ . A positive reference voltage ( $2V_{\Delta+}$ ) applied to Pin 2 determines the positive peak value of the triangle, and a negative reference voltage ( $2V_{\Delta-}$ ) at Pin 7 sets the negative peak value of the triangle waveform. Since the value of the internal current source is fixed at a nominal  $\pm 500 \mu\text{A}$ , the oscillator period is a function of the selected peak-to-peak voltage excursion and the value of  $C_T$ . The theoretical expression for the oscillator period is:

$$T_{\text{OSC}} = \frac{2C_T \text{ dV}}{5 \times 10^{-4}} \quad (\text{Eq.1})$$

where  $C_T$  is the timing capacitor in Farads and dV is  $V_{\text{OSC}}$  in Volts peak-to-peak.

As a design aid, the solutions to Equation 1 over the recommended range of  $T_{\text{OSC}}$  and  $V_{\text{OSC}}$  are given in graphic form in Figure 1. The lower limit on  $T_{\text{OSC}}$  is 1.85  $\mu\text{s}$ , corresponding to a maximum frequency of 350 kHz. The maximum value of  $V_{\text{OSC}}$ , ( $2V_{\Delta+}$ ) - ( $2V_{\Delta-}$ ), is 10 V peak-to-peak for linear waveforms.

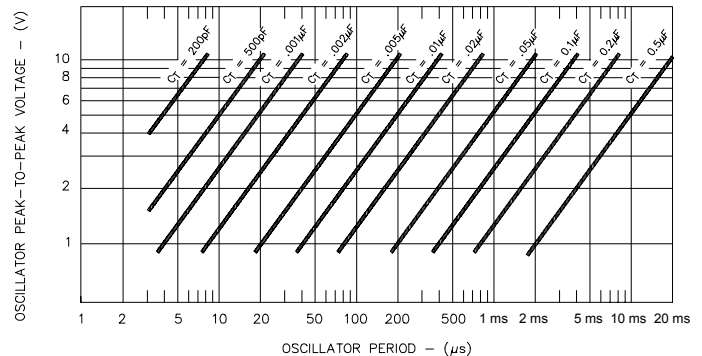

Figure 2 · SG1731 Oscillator Period VS.  $V_{\text{OSC}}$  and  $C_T$

### ERROR AMPLIFIER

The error amplifier of the SG1731 is a conventional internally-compensated operational amplifier with low output impedance. All of the usual feedback and frequency compensation techniques may be used to control the closed-loop gain characteristics. The control supply voltage  $\pm V_S$  will determine the input common mode range and output voltage swing; both will extend to within 3 V of the  $V_S$  supply.

### PULSE WIDTH MODULATION

Pulse width modulation occurs by comparing the triangle waveform to a fixed upper ( $+V_T$ ) and lower ( $-V_T$ ) threshold voltage. A crossing above the upper threshold causes Output A to switch to the HIGH state, and a crossing below

## Application Information (Continued)

the lower threshold causes Output B to switch to the HIGH state. If  $\pm V_s$  is less than  $\pm 8$  V then  $\pm V_T$  can be obtained with resistors from  $\pm V_s$ . If  $\pm V_s$  is greater than  $\pm 8$  V use zeners.

Threshold crossings are generated by shifting the triangle waveform up and down with the error voltage (Pin 5). A positive error voltage will result in a pulse width modulated output at Driver A (Pin 13). Similarly, a negative error voltage produces a pulse train at Driver B (Pin 12). Figure 2 illustrates this process for the case where  $V_{\Delta+}$  is greater than  $V_T$ .

It is important to note that the triangle shifting circuit also attenuates the waveform seen at  $C_T$  by a factor of 2. This results in a waveform at the PWM comparators with a positive peak of  $V_{\Delta+}$  and a negative peak of  $V_{\Delta-}$ , and must be taken into account when selecting the values for  $+V_T$  and  $-V_T$ .

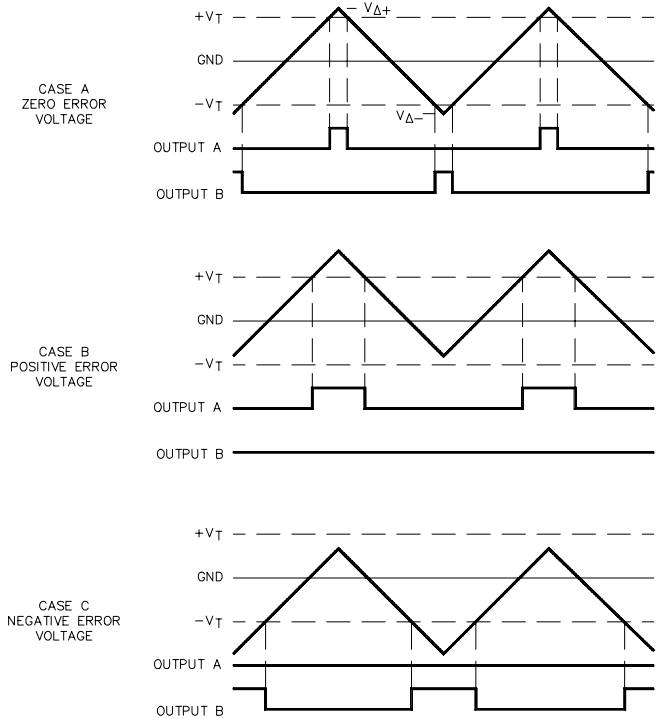

Figure 3 - Pulse Width Modulation with No Deadband

## Application Circuits

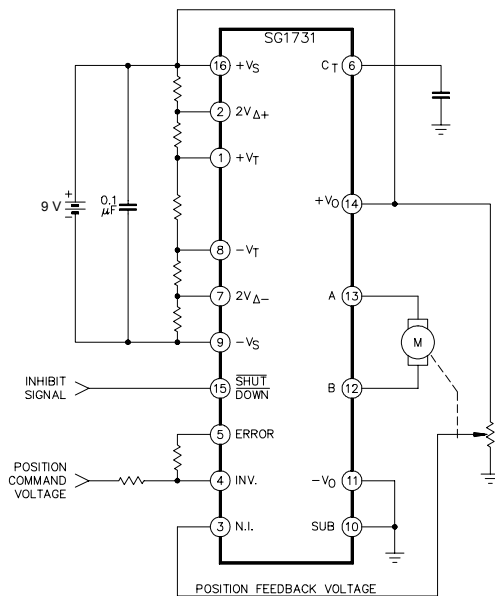

Figure 4

In this simple battery-powered position servo, the control supply and driver supply are both single-ended positive with respect to ground.

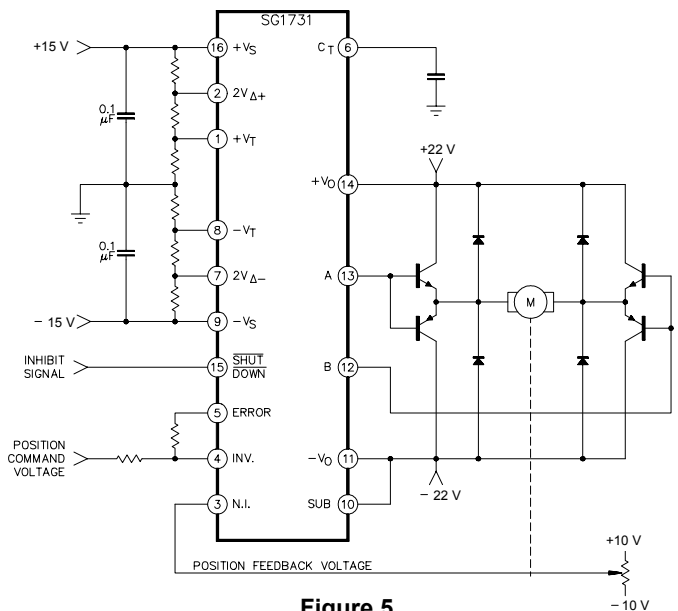
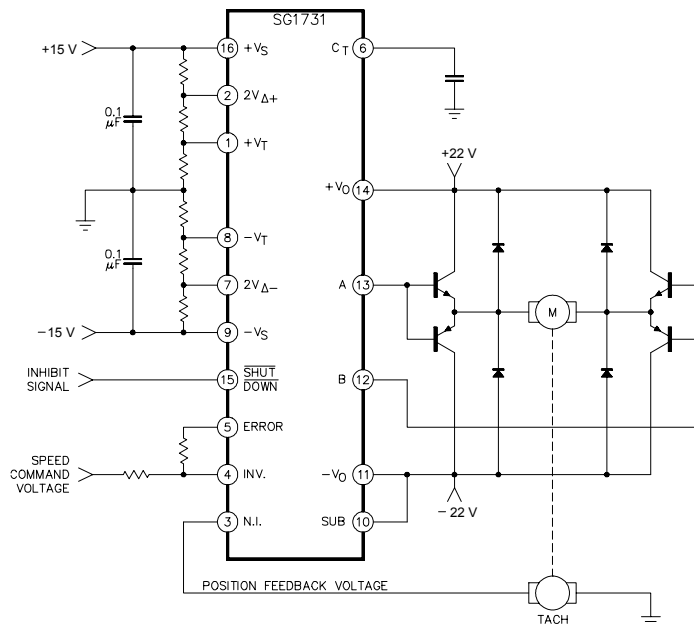

Figure 5

A high torque position servo is obtained by buffering the output drivers to obtain higher output current.

## Application Circuits (Continued)



**Figure 6**

Bi-directional speed control results when the feedback voltage transducer is a tachometer.

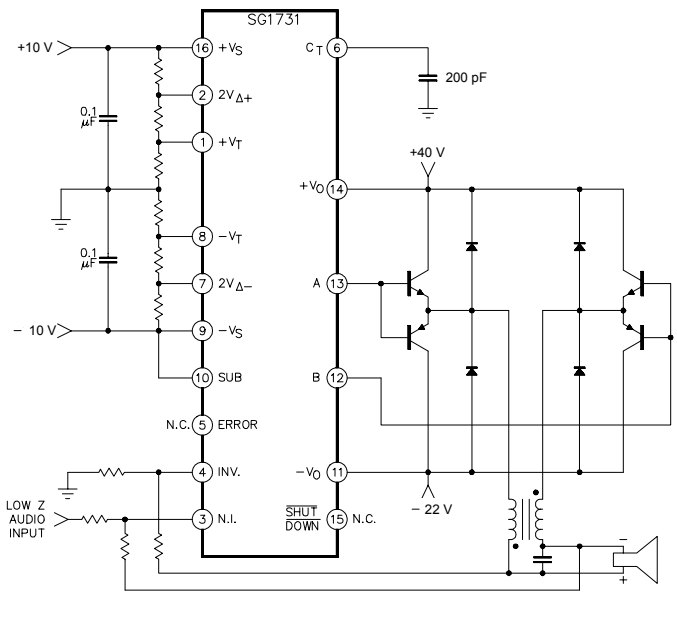

**Figure 7**

The two-quadrant transfer function of the SG1731 is ideal for pulse width modulated audio power amplifiers.

## Connection Diagrams & Ordering Information (See Notes Below)

Package	Part No.	Ambient Temperature Range	Connection Diagram
16-PIN CERAMIC DIP J - PACKAGE	SG1731J- 883B SG1731J-DESC SG1731J	-55°C to 125°C -55°C to 125°C -55°C to 125°C	<p>N Package: RoHS Compliant / Pb-free Transition DC: 0503 N Package: RoHS / Pb-free 100% Matte Tin Lead Finish</p>
16-PIN PLASTIC DIP N - PACKAGE	SG2731N SG3731N	-25°C to 85°C 0°C to 70°C	
20-PIN CERAMIC LEADLESS CHIP CARRIER L- PACKAGE	SG1731L SG1731L- 883B	-55°C to 125°C -55°C to 125°C	

Note 1. All packages are viewed from the top.

Note 2. Contact factory for leadless chip carrier availability.

Note 3. Hermetic Packages J, L use Sn63/Pb37 hot solder lead finish, Contact factory for availability of RoHS versions.

## Package Outline Dimensions

Controlling dimensions are in inches, metric equivalents are shown for general information.

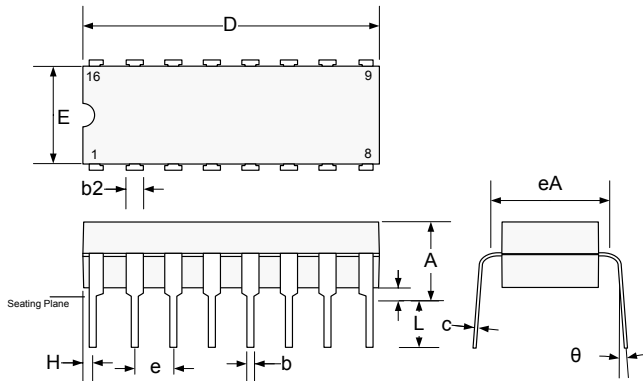

DIM	MILLIMETERS		INCHES	
	MIN	MAX	MIN	MAX
A	-	5.08	-	0.200
b	0.38	0.51	0.015	0.020
b2	1.04	1.65	0.045	0.065
c	0.20	0.38	0.008	0.015
D	19.30	19.94	0.760	0.785
E	5.59	7.11	0.220	0.280
e	2.54 BSC		0.100 BSC	
eA	7.37	7.87	0.290	0.310
H	0.63	1.78	0.025	0.070
L	3.18	5.08	0.125	0.200
$\alpha$	-	15°	-	15°
Q	0.51	1.02	0.020	0.040

**Note:**

Dimensions do not include protrusions; these shall not exceed 0.155mm (.006") on any side. Lead dimension shall not include solder coverage.

**Figure 8 - J 16-Pin Ceramic Dual In-line Package Dimensions**

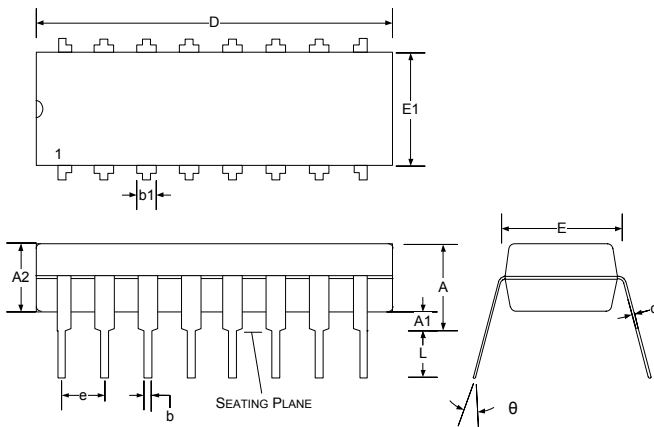

DIM	MILLIMETERS		INCHES	
	MIN	MAX	MIN	MAX
A	-	5.33	-	0.210
A1	0.38	-	0.015	-
A2	3.30 Typ.		0.130 Typ.	
b	0.36	0.56	0.014	0.022
b1	1.14	1.78	0.045	0.070
c	0.20	0.36	0.008	0.014
D	18.67	19.69	0.735	0.775
e	2.54 BSC		0.100 BSC	
E	7.62	8.26	0.300	0.325
E1	6.10	7.11	0.240	0.280
L	2.92	0.381	0.115	0.150
$\theta$	-	15°	-	15°

**Note:**

Dimensions do not include protrusions; these shall not exceed 0.155mm (.006") on any side. Lead dimension shall not include solder coverage.

**Figure 9 - N 16-Pin Plastic Dual In-line Package Dimensions**

## Package Outline Dimensions (Continued)

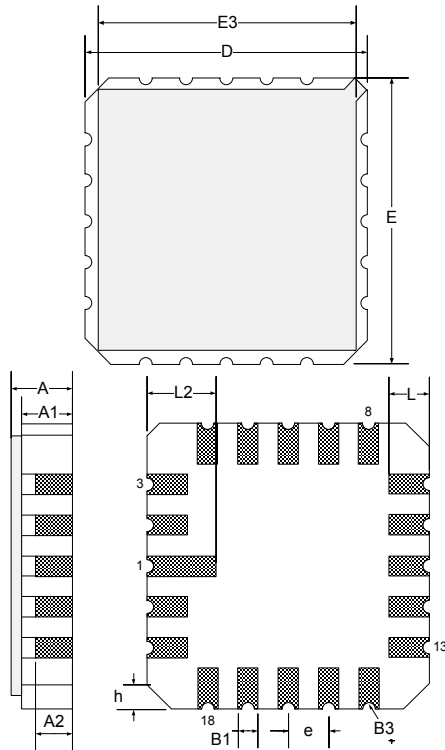

DIM	MILLIMETERS		INCHES	
	MIN	MAX	MIN	MAX
D/E	8.64	9.14	0.340	0.360
E3	-	8.128	-	0.320
e	1.270 BSC		0.050 BSC	
B1	0.635 TYP		0.025 TYP	
L	1.02	1.52	0.040	0.060
A	1.626	2.286	0.064	0.090
h	1.016 TYP		0.040 TYP	
A1	1.372	1.68	0.054	0.066
A2	-	1.168	-	0.046
L2	1.91	2.41	0.075	0.95
B3	0.203R		0.008R	

**Note:**

All exposed metalized area shall be gold plated 60 micro-inch minimum thickness over nickel plated unless otherwise specified in purchase order.

**Figure 10 - L 20-Pin Ceramic LCC Package Outline Dimensions**



**Microsemi Corporate Headquarters**  
One Enterprise, Aliso Viejo,  
CA 92656 USA

**Within the USA:** +1 (800) 713-4113  
**Outside the USA:** +1 (949) 380-6100  
**Sales:** +1 (949) 380-6136  
**Fax:** +1 (949) 215-4996

**E-mail:** [sales.support@microsemi.com](mailto:sales.support@microsemi.com)

© 2015 Microsemi Corporation. All rights reserved. Microsemi and the Microsemi logo are trademarks of Microsemi Corporation. All other trademarks and service marks are the property of their respective owners.

Microsemi Corporation (Nasdaq: MSCC) offers a comprehensive portfolio of semiconductor and system solutions for communications, defense & security, aerospace and industrial markets. Products include high-performance and radiation-hardened analog mixed-signal integrated circuits, FPGAs, SoCs and ASICs; power management products; timing and synchronization devices and precise time solutions, setting the world's standard for time; voice processing devices; RF solutions; discrete components; security technologies and scalable anti-tamper products; Power-over-Ethernet ICs and midspans; as well as custom design capabilities and services. Microsemi is headquartered in Aliso Viejo, Calif., and has approximately 3,400 employees globally. Learn more at [www.microsemi.com](http://www.microsemi.com).

Microsemi makes no warranty, representation, or guarantee regarding the information contained herein or the suitability of its products and services for any particular purpose, nor does Microsemi assume any liability whatsoever arising out of the application or use of any product or circuit. The products sold hereunder and any other products sold by Microsemi have been subject to limited testing and should not be used in conjunction with mission-critical equipment or applications. Any performance specifications are believed to be reliable but are not verified, and Buyer must conduct and complete all performance and other testing of the products, alone and together with, or installed in, any end-products. Buyer shall not rely on any data and performance specifications or parameters provided by Microsemi. It is the Buyer's responsibility to independently determine suitability of any products and to test and verify the same. The information provided by Microsemi hereunder is provided "as is, where is" and with all faults, and the entire risk associated with such information is entirely with the Buyer. Microsemi does not grant, explicitly or implicitly, to any party any patent rights, licenses, or any other IP rights, whether with regard to such information itself or anything described by such information. Information provided in this document is proprietary to Microsemi, and Microsemi reserves the right to make any changes to the information in this document or to any products and services at any time without notice.

## Looking for pricing, stock, or lifecycle information?

Click below to explore more details on WIN SOURCE:

- [View SG1731J on WIN SOURCE](#)
- [Microchip Technology Information](#)

## Optimize Your Supply Chain with WIN SOURCE Solutions

- ✓ Global Sourcing Solution
- ✓ Obsolete Management
- ✓ Cost Control Management
- ✓ Shortage Management
- ✓ Alternative Solution
- ✓ Excess Inventory Management