



**THE DATASHEET OF  
SNJ54HC4024J**



- Package Options Include Plastic "Small Outline" Packages, Ceramic Chip Carriers, and Standard Plastic and Ceramic 300-mil DIPs
- Dependable Texas Instruments Quality and Reliability

**description**

The 'HC4024 is an asynchronous 7-stage binary counter designed with an input pulse-shaping circuit. The outputs of all stages are available externally. A high clear signal asynchronously clears the counter and resets all outputs low. The count is advanced on the high-to-low transition of the clock pulse. Applications include time-delay circuits, counter controls, and frequency-dividing circuits.

The SN54HC4024 is characterized for operation over the full military temperature range of -55°C to 125°C. The SN74HC4024 is characterized for operation from -40°C to 85°C.

**logic symbol†**

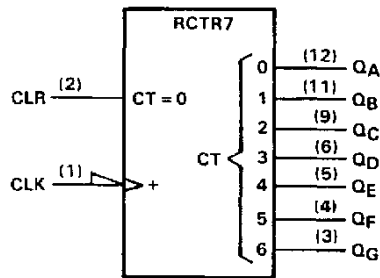

†This symbol is in accordance with ANSI/IEEE Std 91-1984 and IEC Publication 617-12.

Pin numbers shown are for D, J, and N packages.

SN54HC4024 . . . J PACKAGE  
SN74HC4024 . . . D OR N PACKAGE  
(TOP VIEW)

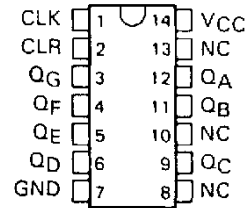

SN54HC4024 . . . FK PACKAGE  
(TOP VIEW)

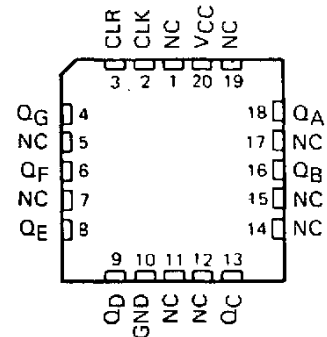

NC—No internal connection

PRODUCTION DATA documents contain information current as of publication date. Products conform to specifications per the terms of Texas Instruments standard warranty. Production processing does not necessarily include testing of all parameters.



POST OFFICE BOX 655012 • DALLAS, TEXAS 75265

Copyright © 1989, Texas Instruments Incorporated

# SN54HC4024, SN74HC4024 ASYNCHRONOUS 7-BIT BINARY COUNTERS

logic diagram (positive logic)

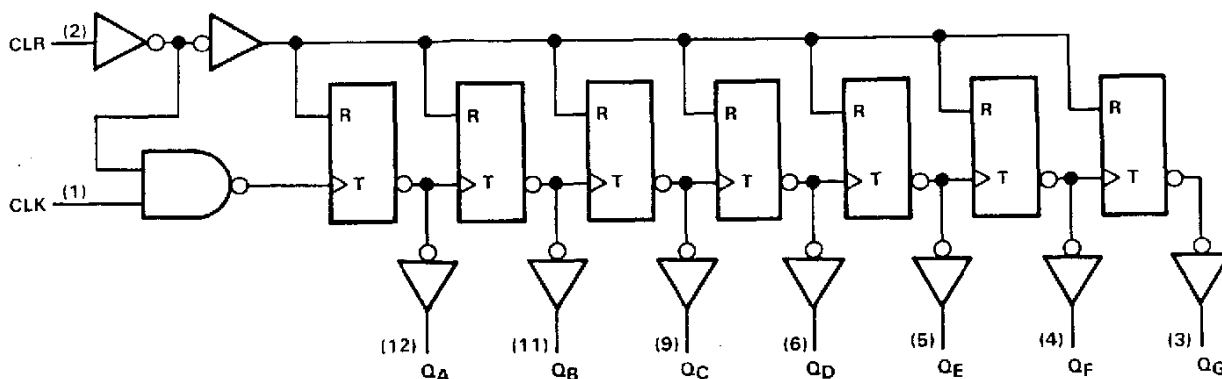

Pin numbers shown are for D, J, and N packages.

typical clear and count sequence

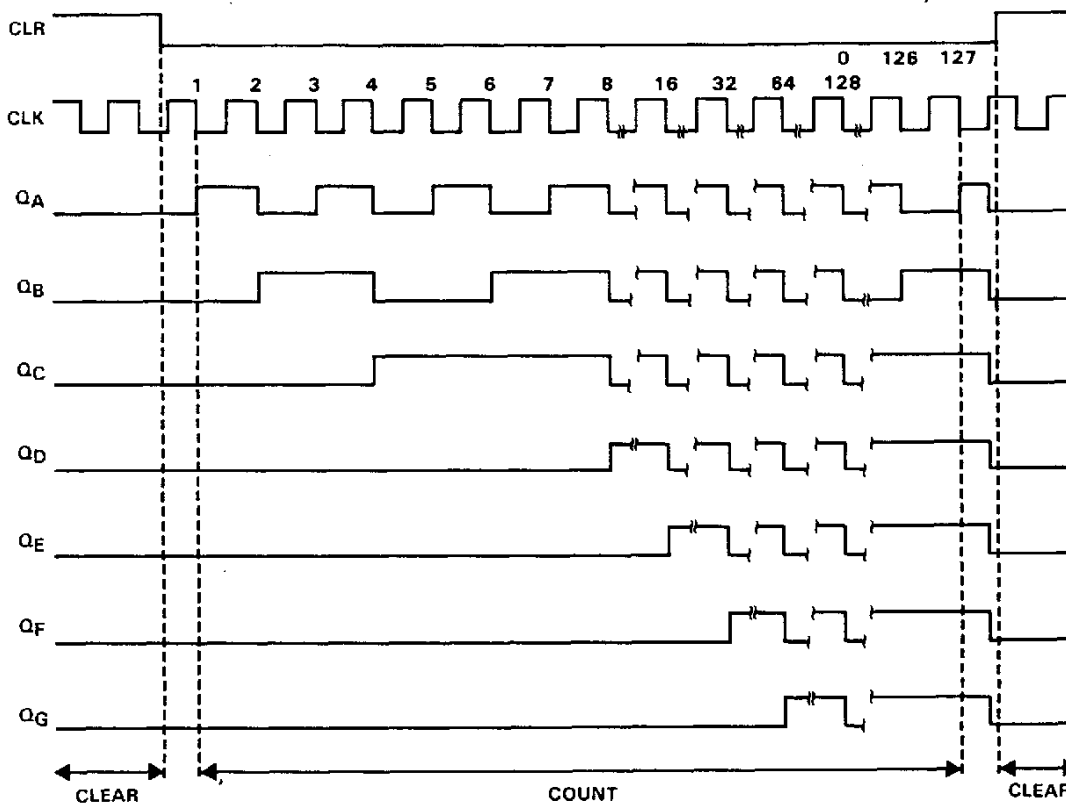

TEXAS  
INSTRUMENTS

POST OFFICE BOX 655012 • DALLAS, TEXAS 75265

# SN54HC4024, SN74HC4024 ASYNCHRONOUS 7-BIT BINARY COUNTERS

## absolute maximum ratings over operating free-air temperature range†

|   |                |
|---|----------------|
| Supply voltage, $V_{CC}$ .....  | -0.5 V to 7 V  |
| Input clamp current, $I_{IK}$ ( $V_I < 0$ or $V_I > V_{CC}$ ) .....         | $\pm 20$ mA    |
| Output clamp current, $I_{OK}$ ( $V_O < 0$ or $V_O > V_{CC}$ ) .....        | $\pm 20$ mA    |
| Continuous output current, $I_O$ ( $V_O = 0$ to $V_{CC}$ ) .....            | $\pm 25$ mA    |
| Continuous current through $V_{CC}$ or GND pins .....                       | $\pm 50$ mA    |
| Lead temperature 1,6 mm (1/16 in) from case for 60 s: FK or J package ..... | 300°C          |
| Lead temperature 1,6 mm (1/16 in) from case for 10 s: D or N package .....  | 260°C          |
| Storage temperature range .....   | -65°C to 150°C |

† Stresses beyond those listed under "absolute maximum ratings" may cause permanent damage to the device. These are stress ratings only, and functional operation of the device at these or any other conditions beyond those indicated under "recommended operating conditions" is not implied. Exposure to absolute-maximum-rated conditions for extended periods may affect device reliability.

## recommended operating conditions

|          |  | SN54HC4024       |     |      | SN74HC4024       |                  |      | UNIT |
|----------|--|------------------|-----|------|------------------|------------------|------|------|
|          |  | MIN              | NOM | MAX  | MIN              | NOM              | MAX  |      |
| $V_{CC}$ | Supply voltage                         | 2                | 5   | 6    | 2                | 5                | 6    | V    |
| $V_{IH}$ | High-level input voltage               | $V_{CC} = 2$ V   |     | 1.5  | $V_{CC} = 2$ V   |                  | 1.5  | V    |
|          |  | $V_{CC} = 4.5$ V |     | 3.15 | $V_{CC} = 4.5$ V |                  | 3.15 |      |
|          |  | $V_{CC} = 6$ V   |     | 4.2  | $V_{CC} = 6$ V   |                  | 4.2  |      |
| $V_{IL}$ | Low-level input voltage                | $V_{CC} = 2$ V   |     | 0    | 0.3              | $V_{CC} = 2$ V   |      | V    |
|          |  | $V_{CC} = 4.5$ V |     | 0    | 0.9              | $V_{CC} = 4.5$ V |      |      |
|          |  | $V_{CC} = 6$ V   |     | 0    | 1.2              | $V_{CC} = 6$ V   |      |      |
| $V_I$    | Input voltage                          | 0                |     |      | $V_{CC}$         |                  |      | V    |
| $V_O$    | Output voltage                         | 0                |     |      | $V_{CC}$         |                  |      | V    |
| $t_t$    | Input transition (rise and fall) times | $V_{CC} = 2$ V   |     | 0    | 1000             | $V_{CC} = 2$ V   |      | ns   |
|          |  | $V_{CC} = 4.5$ V |     | 0    | 500              | $V_{CC} = 4.5$ V |      |      |
|          |  | $V_{CC} = 6$ V   |     | 0    | 400              | $V_{CC} = 6$ V   |      |      |
| $T_A$    | Operating free-air temperature         | -55              |     |      | 125              |                  |      | °C   |

## electrical characteristics over recommended operating free-air temperature range (unless otherwise noted)

| PARAMETER | TEST CONDITIONS   | $V_{CC}$ | $T_A = 25^\circ\text{C}$ |           |           | SN54HC4024 |            | SN74HC4024 |            | UNIT          |
|-----------|---|----------|--------------------------|-----------|-----------|------------|------------|------------|------------|---------------|
|           |   |          | MIN                      | TYP       | MAX       | MIN        | MAX        | MIN        | MAX        |               |
| $V_{OH}$  | $V_I = V_{IH}$ or $V_{IL}$ , $I_{OH} = -20 \mu\text{A}$ | 2 V      | 1.9                      | 1.998     |           | 1.9        |            | 1.9        | V          |               |
|           |   | 4.5 V    | 4.4                      | 4.499     |           | 4.4        |            | 4.4        |            |               |
|           |   | 6 V      | 5.9                      | 5.999     |           | 5.9        |            | 5.9        |            |               |
|           | $V_I = V_{IH}$ or $V_{IL}$ , $I_{OH} = -4$ mA           | 4.5 V    | 3.98                     | 4.30      |           | 3.7        |            | 3.84       |            |               |
|           | $V_I = V_{IH}$ or $V_{IL}$ , $I_{OH} = -5.2$ mA         | 6 V      | 5.48                     | 5.80      |           | 5.2        |            | 5.34       |            |               |
| $V_{OL}$  | $V_I = V_{IH}$ or $V_{IL}$ , $I_{OL} = 20 \mu\text{A}$  | 2 V      |                          | 0.002     | 0.1       |            | 0.1        |            | 0.1        | V             |
|           |   | 4.5 V    |                          | 0.001     | 0.1       |            | 0.1        |            | 0.1        |               |
|           |   | 6 V      |                          | 0.001     | 0.1       |            | 0.1        |            | 0.1        |               |
|           | $V_I = V_{IH}$ or $V_{IL}$ , $I_{OL} = 4$ mA            | 4.5 V    |                          | 0.17      | 0.26      |            | 0.4        |            | 0.33       |               |
|           | $V_I = V_{IH}$ or $V_{IL}$ , $I_{OL} = 5.2$ mA          | 6 V      |                          | 0.15      | 0.26      |            | 0.4        |            | 0.33       |               |
| $I_I$     | $V_I = V_{CC}$ or 0                                     | 6 V      |                          | $\pm 0.1$ | $\pm 100$ |            | $\pm 1000$ |            | $\pm 1000$ | nA            |
| $I_{CC}$  | $V_I = V_{CC}$ or 0, $I_O = 0$                          | 6 V      |                          |           | 8         |            | 160        |            | 80         | $\mu\text{A}$ |
| $C_i$     |   | 2 to 6 V |                          | 3         | 10        |            | 10         |            | 10         | pF            |



**SN54HC4024, SN74HC4024**  
**ASYNCHRONOUS 7-BIT BINARY COUNTERS**

timing requirements over recommended operating free-air temperature range (unless otherwise noted)

|                    |                                 | V <sub>CC</sub> | T <sub>A</sub> = 25 °C |     | SN54HC4024 |     | SN74HC4024 |     | UNIT |
|--------------------|---------------------------------|-----------------|------------------------|-----|------------|-----|------------|-----|------|
|                    |                                 |                 | MIN                    | MAX | MIN        | MAX | MIN        | MAX |      |
| f <sub>clock</sub> | Clock frequency                 | 2 V             | 0                      | 5.5 | 0          | 3.7 | 0          | 4.3 | MHz  |
|                    |                                 | 4.5 V           | 0                      | 28  | 0          | 19  | 0          | 22  |      |
|                    |                                 | 6 V             | 0                      | 33  | 0          | 22  | 0          | 25  |      |
| t <sub>w</sub>     | Pulse duration                  | CLK high or low | 2 V                    | 90  |            | 135 |            | 115 | ns   |
|                    |                                 |                 | 4.5 V                  | 18  |            | 27  |            | 23  |      |
|                    |                                 |                 | 6 V                    | 15  |            | 23  |            | 20  |      |
|                    | CLR high                        | 2 V             | 80                     |     | 120        |     | 100        | ns  |      |
|                    |                                 | 4.5 V           | 16                     |     | 24         |     | 20         |     |      |
|                    |                                 | 6 V             | 14                     |     | 20         |     | 17         |     |      |
| t <sub>su</sub>    | Setup time, CLR low before CLK↓ | 2 V             | 80                     |     | 120        |     | 100        | ns  |      |
|                    |                                 | 4.5 V           | 16                     |     | 24         |     | 20         |     |      |
|                    |                                 | 6 V             | 14                     |     | 20         |     | 17         |     |      |

switching characteristics over recommended operating free-air temperature range (unless otherwise noted), C<sub>L</sub> = 50 pF (see Note 1)

| PARAMETER        | FROM (INPUT) | TO (OUTPUT)    | V <sub>CC</sub> | T <sub>A</sub> = 25 °C |     |     | SN54HC4024 |     | SN74HC4024 |     | UNIT |
|------------------|--------------|----------------|-----------------|------------------------|-----|-----|------------|-----|------------|-----|------|
|                  |              |                |                 | MIN                    | TYP | MAX | MIN        | MAX | MIN        | MAX |      |
| f <sub>max</sub> |              | Q <sub>A</sub> | 2 V             | 5.5                    | 10  |     | 3.7        |     | 4.3        | MHz |      |
|                  |              |                | 4.5 V           | 28                     | 50  |     | 19         |     | 22         |     |      |
|                  |              |                | 6 V             | 33                     | 60  |     | 22         |     | 26         |     |      |
| t <sub>pd</sub>  | CLK          | Q <sub>A</sub> | 2 V             |                        | 56  | 120 |            | 180 |            | 150 | ns   |
|                  |              |                | 4.5 V           |                        | 16  | 24  |            | 36  |            | 30  |      |
|                  |              |                | 6 V             |                        | 12  | 20  |            | 31  |            | 26  |      |
| t <sub>PHL</sub> | CLR          | Any            | 2 V             |                        | 61  | 130 |            | 195 |            | 165 | ns   |
|                  |              |                | 4.5 V           |                        | 17  | 26  |            | 39  |            | 32  |      |
|                  |              |                | 6 V             |                        | 13  | 22  |            | 33  |            | 28  |      |
| t <sub>t</sub>   |              | Q <sub>A</sub> | 2 V             |                        | 28  | 75  |            | 110 |            | 95  | ns   |
|                  |              |                | 4.5 V           |                        | 8   | 15  |            | 22  |            | 19  |      |
|                  |              |                | 6 V             |                        | 6   | 13  |            | 19  |            | 16  |      |

|                 |                               |                                 |           |
|-----------------|-------------------------------|---------------------------------|-----------|
| C <sub>pd</sub> | Power dissipation capacitance | No load, T <sub>A</sub> = 25 °C | 40 pF typ |
|-----------------|-------------------------------|---------------------------------|-----------|

Note 1: Load circuits and voltage waveforms are shown in Section 1.



POST OFFICE BOX 655012 • DALLAS, TEXAS 75265

**PACKAGING INFORMATION**

| Orderable Device | Status<br>(1) | Package Type | Package Drawing | Pins | Package Qty | Eco Plan<br>(2)  | Lead finish/<br>Ball material<br>(6) | MSL Peak Temp<br>(3) | Op Temp (°C) | Device Marking<br>(4/5) | Samples |
|------------------|---------------|--------------|-----------------|------|-------------|------------------|--------------------------------------|----------------------|--------------|-------------------------|---------|
| SN54HC4024J      | ACTIVE        | CDIP         | J               | 14   | 25          | Non-RoHS & Green | SNPB                                 | N / A for Pkg Type   | -55 to 125   | SN54HC4024J             | Samples |

(1) The marketing status values are defined as follows:

**ACTIVE:** Product device recommended for new designs.

**LIFEBUY:** TI has announced that the device will be discontinued, and a lifetime-buy period is in effect.

**NRND:** Not recommended for new designs. Device is in production to support existing customers, but TI does not recommend using this part in a new design.

**PREVIEW:** Device has been announced but is not in production. Samples may or may not be available.

**OBSOLETE:** TI has discontinued the production of the device.

(2) **RoHS:** TI defines "RoHS" to mean semiconductor products that are compliant with the current EU RoHS requirements for all 10 RoHS substances, including the requirement that RoHS substance do not exceed 0.1% by weight in homogeneous materials. Where designed to be soldered at high temperatures, "RoHS" products are suitable for use in specified lead-free processes. TI may reference these types of products as "Pb-Free".

**RoHS Exempt:** TI defines "RoHS Exempt" to mean products that contain lead but are compliant with EU RoHS pursuant to a specific EU RoHS exemption.

**Green:** TI defines "Green" to mean the content of Chlorine (Cl) and Bromine (Br) based flame retardants meet JS709B low halogen requirements of <=1000ppm threshold. Antimony trioxide based flame retardants must also meet the <=1000ppm threshold requirement.

(3) MSL, Peak Temp. - The Moisture Sensitivity Level rating according to the JEDEC industry standard classifications, and peak solder temperature.

(4) There may be additional marking, which relates to the logo, the lot trace code information, or the environmental category on the device.

(5) Multiple Device Markings will be inside parentheses. Only one Device Marking contained in parentheses and separated by a "~" will appear on a device. If a line is indented then it is a continuation of the previous line and the two combined represent the entire Device Marking for that device.

(6) Lead finish/Ball material - Orderable Devices may have multiple material finish options. Finish options are separated by a vertical ruled line. Lead finish/Ball material values may wrap to two lines if the finish value exceeds the maximum column width.

**Important Information and Disclaimer:**The information provided on this page represents TI's knowledge and belief as of the date that it is provided. TI bases its knowledge and belief on information provided by third parties, and makes no representation or warranty as to the accuracy of such information. Efforts are underway to better integrate information from third parties. TI has taken and continues to take reasonable steps to provide representative and accurate information but may not have conducted destructive testing or chemical analysis on incoming materials and chemicals. TI and TI suppliers consider certain information to be proprietary, and thus CAS numbers and other limited information may not be available for release.

In no event shall TI's liability arising out of such information exceed the total purchase price of the TI part(s) at issue in this document sold by TI to Customer on an annual basis.

J 14

**GENERIC PACKAGE VIEW**  
**CDIP - 5.08 mm max height**  
CERAMIC DUAL IN LINE PACKAGE

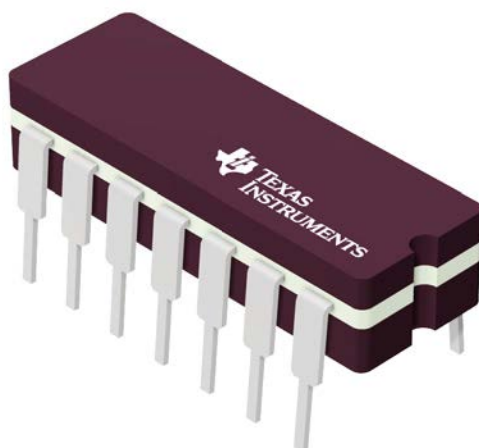

Images above are just a representation of the package family, actual package may vary.  
Refer to the product data sheet for package details.

4040083-5/G

J0014A

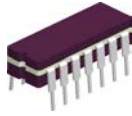

# PACKAGE OUTLINE

CDIP - 5.08 mm max height

CERAMIC DUAL IN LINE PACKAGE

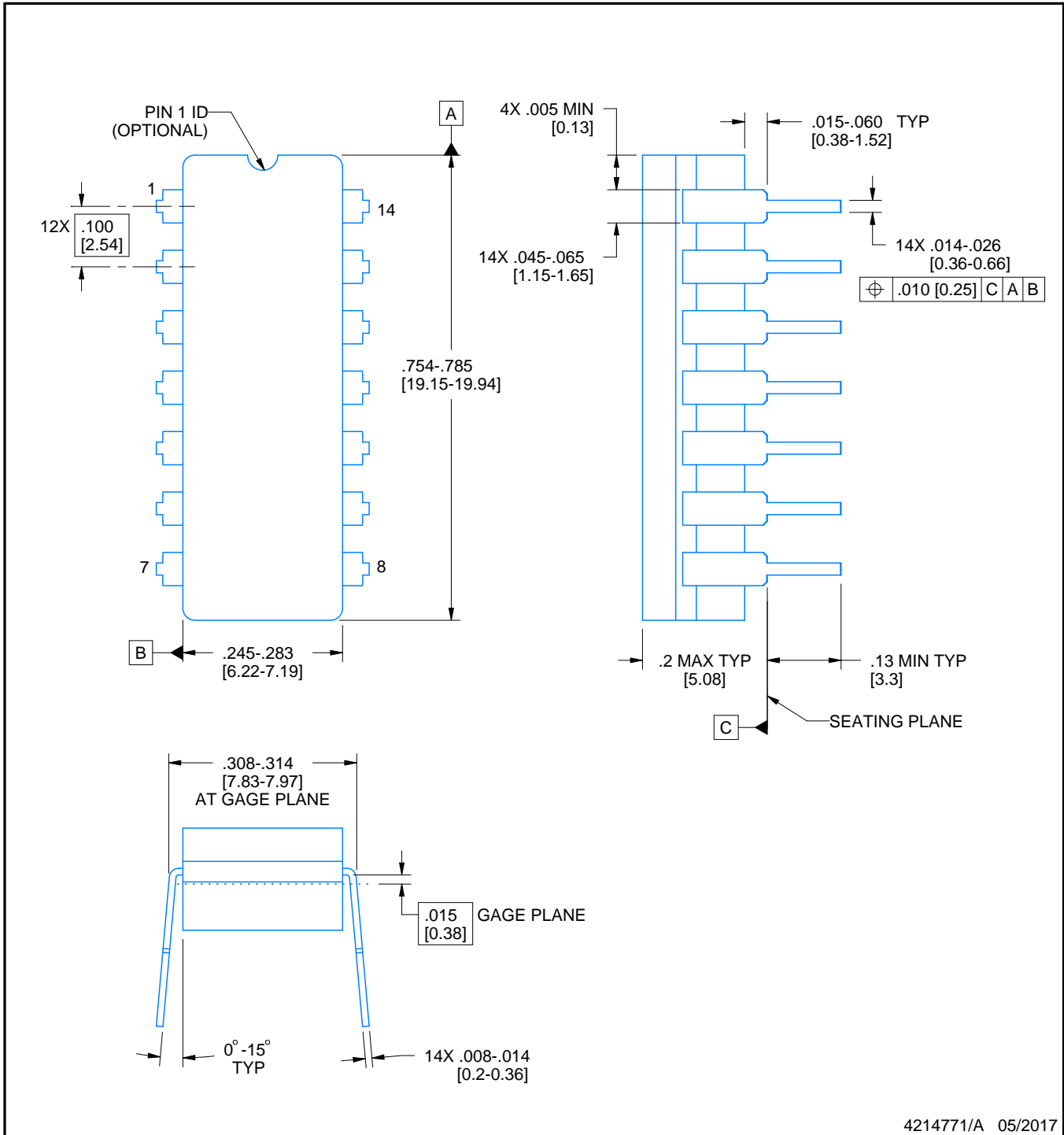

4214771/A 05/2017

NOTES:

1. All controlling linear dimensions are in inches. Dimensions in brackets are in millimeters. Any dimension in brackets or parenthesis are for reference only. Dimensioning and tolerancing per ASME Y14.5M.
2. This drawing is subject to change without notice.
3. This package is hermetically sealed with a ceramic lid using glass frit.
4. Index point is provided on cap for terminal identification only and on press ceramic glass frit seal only.
5. Falls within MIL-STD-1835 and GDIP1-T14.

# EXAMPLE BOARD LAYOUT

J0014A

CDIP - 5.08 mm max height

CERAMIC DUAL IN LINE PACKAGE

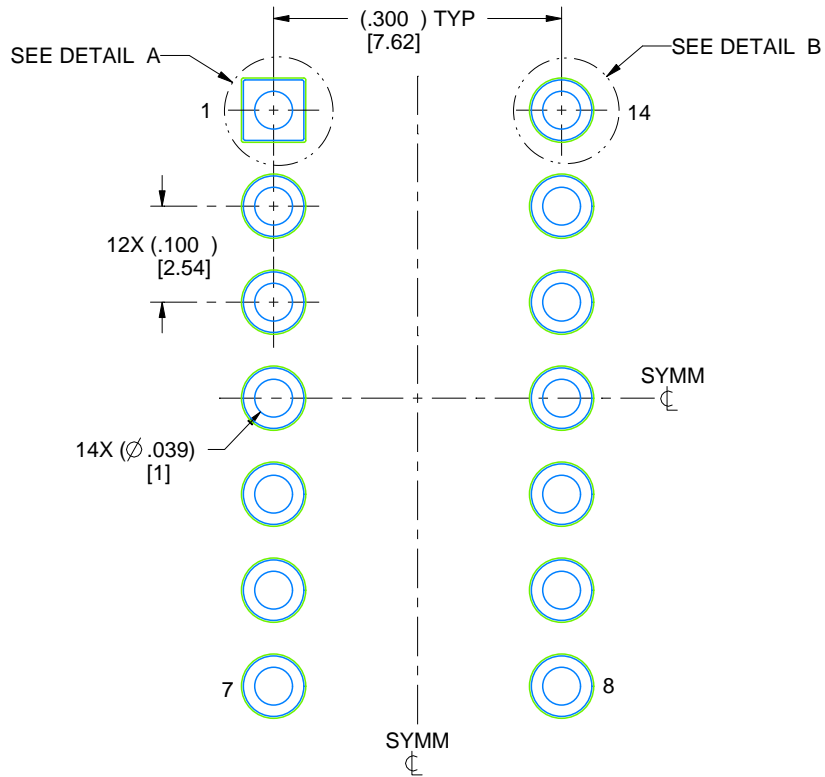

LAND PATTERN EXAMPLE  
NON-SOLDER MASK DEFINED  
SCALE: 5X

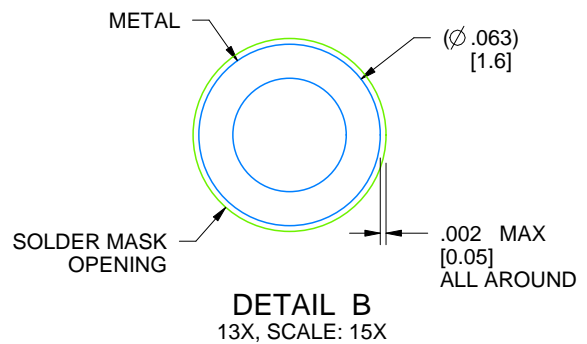
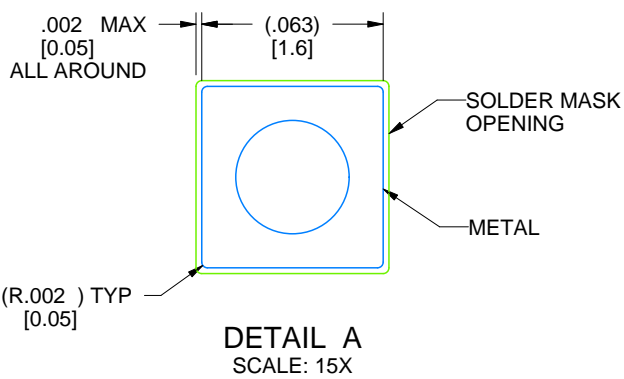

4214771/A 05/2017

## IMPORTANT NOTICE AND DISCLAIMER

TI PROVIDES TECHNICAL AND RELIABILITY DATA (INCLUDING DATA SHEETS), DESIGN RESOURCES (INCLUDING REFERENCE DESIGNS), APPLICATION OR OTHER DESIGN ADVICE, WEB TOOLS, SAFETY INFORMATION, AND OTHER RESOURCES "AS IS" AND WITH ALL FAULTS, AND DISCLAIMS ALL WARRANTIES, EXPRESS AND IMPLIED, INCLUDING WITHOUT LIMITATION ANY IMPLIED WARRANTIES OF MERCHANTABILITY, FITNESS FOR A PARTICULAR PURPOSE OR NON-INFRINGEMENT OF THIRD PARTY INTELLECTUAL PROPERTY RIGHTS.

These resources are intended for skilled developers designing with TI products. You are solely responsible for (1) selecting the appropriate TI products for your application, (2) designing, validating and testing your application, and (3) ensuring your application meets applicable standards, and any other safety, security, regulatory or other requirements.

These resources are subject to change without notice. TI grants you permission to use these resources only for development of an application that uses the TI products described in the resource. Other reproduction and display of these resources is prohibited. No license is granted to any other TI intellectual property right or to any third party intellectual property right. TI disclaims responsibility for, and you will fully indemnify TI and its representatives against, any claims, damages, costs, losses, and liabilities arising out of your use of these resources.

TI's products are provided subject to [TI's Terms of Sale](#) or other applicable terms available either on [ti.com](https://www.ti.com) or provided in conjunction with such TI products. TI's provision of these resources does not expand or otherwise alter TI's applicable warranties or warranty disclaimers for TI products.

TI objects to and rejects any additional or different terms you may have proposed.

Mailing Address: Texas Instruments, Post Office Box 655303, Dallas, Texas 75265  
Copyright © 2024, Texas Instruments Incorporated

## Looking for pricing, stock, or lifecycle information?

Click below to explore more details on WIN SOURCE:

 [View SNJ54HC4024J on WIN SOURCE](#)

 [Texas Instruments](#) Information

## Optimize Your Supply Chain with WIN SOURCE Solutions

-  Global Sourcing Solution
-  Obsolete Management
-  Cost Control Management
-  Shortage Management
-  Alternative Solution
-  Excess Inventory Management