



**THE DATASHEET OF
PI3B3257Q**



Features

- Near-Zero propagation delay
- 5Ω switches connect inputs to outputs
- Fast Switching Speed: 4.8ns max.
- Ultra-Low Quiescent Power: 0.1μA typical
 - Ideally suited for notebook applications
- Pin compatible with 74 series 257 logic devices
- Packaging (Pb-free & Green available):
 - 16-pin, QSOP (Q)
 - 16-pin, SOIC (W)
 - 16-pin, TSSOP (L)
 - 16-pin, UQFN (ZHD)

Block Diagram

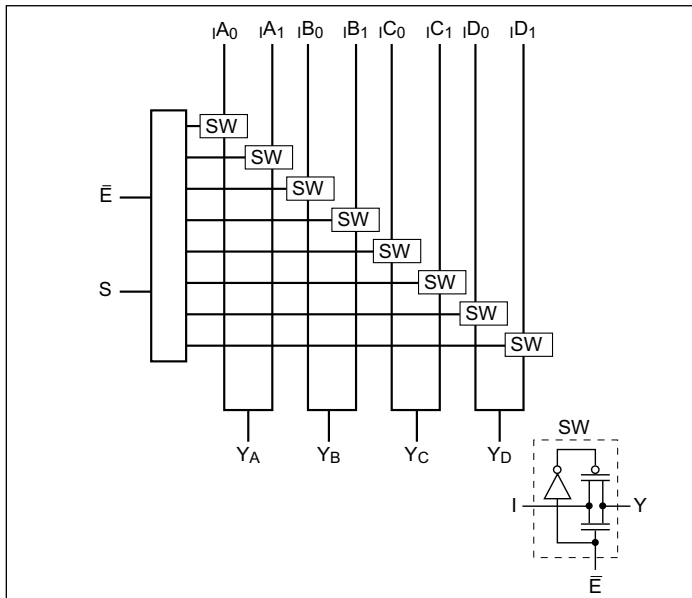

Pin Configuration (QSOP, SOIC, TSSOP)

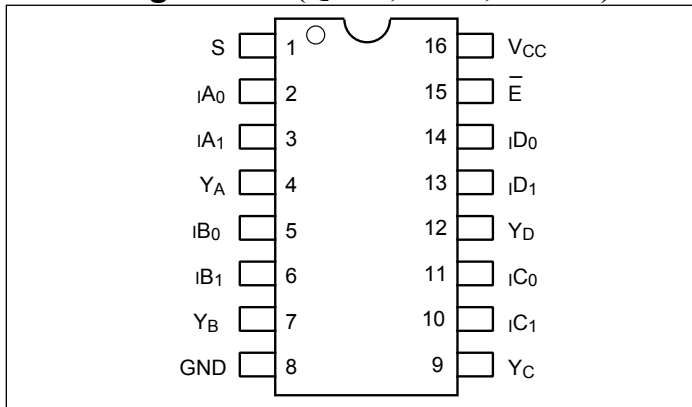

Description

The PI3B3257 is a 3.3 Volt, Quad 2:1 multiplexer/demultiplexer with three-state outputs that is pinout and function compatible with the PI74FCT257T, 74F257, and 74ALS/AS/LS257. Inputs can be connected to outputs with low On-Resistance (5Ω) with no additional ground bounce noise or propagation delay.

Pin Configuration (UQFN)

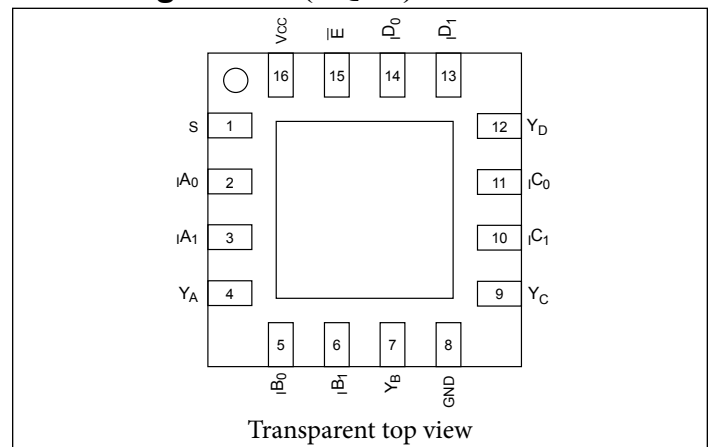

Truth Table⁽¹⁾

\bar{E}	S	Y _A	Y _B	Y _C	Y _D	Function
H	X	Hi-Z	Hi-Z	Hi-Z	Hi-Z	Disable
L	L	iA ₀	iB ₀	iC ₀	iD ₀	S = 0
L	H	iA ₁	iB ₁	iC ₁	iD ₁	S = 1

Note:

1. H = High Voltage Level
L = Low Voltage Level

Pin Description

Pin Name	Description
iA _N -iD _N	Data Inputs
S	Select Inputs
\bar{E}	Enable
Y _A -Y _D	Data Outputs
GND	Ground ⁽¹⁾
V _{CC}	Power
NC	No Connect

Note 1: UQFN16 package die supply ground is connected to both GND pin and exposed center pad. GND pin must be connected to supply ground for proper device operation. For enhanced thermal, electrical, and board level performance, the exposed pad needs to be soldered to the board using a corresponding thermal pad on the board and for proper heat conduction through the board, thermal vias need to be incorporated in the PCB in the thermal pad region.

Maximum Ratings

(Above which the useful life may be impaired. For user guidelines, not tested.)

Storage Temperature	-65°C to +150°C
Ambient Temperature with Power Applied	-40°C to +85°C
Supply Voltage to Ground Potential.....	-0.5V to +4.6V
DC Input Voltage	-0.5V to +4.6V
DC Output Current.....	120mA
Power Dissipation	0.5W

Note:

Stresses greater than those listed under MAXIMUM RATINGS may cause permanent damage to the device. This is a stress rating only and functional operation of the device at these or any other conditions above those indicated in the operational sections of this specification is not implied. Exposure to absolute maximum rating conditions for extended periods may affect reliability.

DC Electrical Characteristics (Over the Operating Range, T_A = -40°C to +85°C, V_{CC} = 3.3V ±10%)

Parameters	Description	Test Conditions ⁽¹⁾	Min.	Typ. ⁽²⁾	Max.	Units
V _{IH}	Input HIGH Voltage	Guaranteed Logic HIGH Level	2			V
V _{IL}	Input LOW Voltage	Guaranteed Logic LOW Level	-0.5		0.8	
I _{IH}	Input HIGH Current	V _{CC} = Max., V _{IN} = V _{CC}			±1	µA
I _{IL}	Input LOW Current	V _{CC} = Max., V _{IN} = GND			±1	
I _{OZH}	High Impedance Output Current	0 ≤ I _n , Y _n ≤ V _{CC}			±1	
V _{IK}	Clamp Diode Voltage	V _{CC} = Min., I _{IN} = -18mA			-1.2	V
R _{ON}	Switch On-Resistance ⁽³⁾	V _{CC} = Min., V _{IN} = 0.0V, I _{ON} = 48mA or 64mA		5	8	Ω
		V _{CC} = Min., V _{IN} = 2.4V, I _{ON} = 15mA		8	17	

Notes:

- For Max. or Min. conditions, use appropriate value specified under Electrical Characteristics for the applicable device type.
- Typical values are at V_{CC} = 3.3V, T_A = 25°C ambient and maximum loading.
- Measured by the voltage drop between I and Y pin at indicated current through the switch. On-Resistance is determined by the lower of the voltages on the two (I,Y) pins.

Capacitance (T_A = 25°C, f = 1 MHz)

Parameters ⁽¹⁾	Description	Test Conditions	Typ.	Units
C _{IN}	Input Capacitance	V _{IN} = 0V	3.0	pF
C _{OFFYN}	Y _N Capacitance, Switch OFF		17.0	
C _{OFFIN}	I _N Capacitance, Switch OFF		8.5	
C _{ON}	I _N /Y _N Capacitance, Switch ON		25	

Notes:

- This parameter is determined by device characterization but is not production tested.

Power Supply Characteristics

Parameters	Description	Test Conditions ⁽¹⁾		Min.	Typ. ⁽²⁾	Max.	Units
I _{CC}	Quiescent Power Supply Current	V _{CC} = Max.	V _{IN} = GND or V _{CC}		0.1	3.0	µA
ΔI _{CC}	Supply Current per Input @ TTL HIGH ^(3, 4)	V _{CC} = Max.	V _{IN} = 3.0			750	

Notes:

- For Max. or Min. conditions, use appropriate value specified under Electrical Characteristics for the applicable device.
- Typical values are at V_{CC} = 3.3V, +25°C ambient.
- Per TTL driven input (control inputs only); I and Y pins do not contribute to I_{CC}.
- This current applies to the control inputs only and represent the current required to switch internal capacitance at the specified frequency. The I and Y inputs generate no significant AC or DC currents as they transition. This parameter is not tested, but is guaranteed by design.

PI3B3257

Switching Characteristics Over Operating Range

Parameters	Description	Conditions	PI3B3257		Units
			Com.		
			Min.	Max.	
t _{IY}	Propagation Delay In to Y _n ^(1,2)	C _L = 50pF R _L = 500Ω		0.25	ns
t _{SY}	Bus Select Time, S _n to Y _n		1	4.5	
t _{PZH} t _{PZL}	Bus Enable Time, E to Y _n		1	4.5	
t _{PHZ} t _{PLZ}	Bus Disable Time, E to Y _n		1	4.8	

Notes:

1. This parameter is guaranteed but not tested on Propagation Delays.
2. The bus switch contributes no propagational delay other than the RC delay of the On-Resistance of the switch and the load capacitance. The switch's time constant alone is of the order of 0.25ns for 50pF load. Since this time constant is much smaller than the rise/fall times of typical driving signals, it adds very little propagational delay to the system. Propagational delay of the bus switch when used in a system is determined by the driving circuit on the driving side of the switch and its interaction with the load on the driven side.

Applications Information

Logic Inputs

The logic control inputs can be driven up to +3.6V regardless of the supply voltage. For example, given a + 3.3V supply, IN may be driven low to 0V and high to 3.6V. Driving IN Rail-to-Rail® minimizes power consumption.

Power-Supply Sequencing and Hot-Plug Information

Proper power-supply sequencing is recommended for all CMOS devices. Always apply V_{CC} and GND before applying signals to input/output or control pins.

Rail-to-Rail is a registered trademark of Nippon Motorola, Ltd.

Part Marking

Q Package

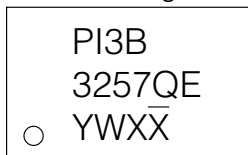

Y: Year
W: Workweek
1st X: Assembly Site Code
2nd X: Fab Site Code

W Package



YY: Date Code (Year)
WW: Date Code (Workweek)
1st X: Assembly Site Code
2nd X: Fab Site Code

L Package

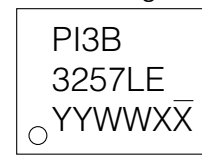

YY: Year
WW: Workweek
1st X: Assembly Site Code
2nd X: Fab Site Code

ZHD Package



Y: Year
W: Workweek
1st X: Assembly Site Code
2nd X: Fab Site Code

PI3B3257

Packaging Mechanical: 16-QSOP (Q)

SYMBOLS	MIN.	NOM.	MAX.
A	—	—	0.069
A1	0.004	—	0.0098
A2	0.049	—	—
b	0.008	—	0.012
c	0.004	—	0.010
D	0.189	0.193	0.197
E1	0.150	0.154	0.158
E	0.228	0.236	0.244
L	0.016	—	0.050
L1	0.041 REF.		
e	0.025 BSC.		
θ°	0	—	8

UNIT : INCH

NOTES:
 1. ALL DIMENSIONS IN INCH. ANGLES IN DEGREES.
 2. JEDEC MO-137E.
 3. DIMENSIONS DOES NOT INCLUDE MOLD FLASH, PROTRUSIONS OR GATE BURRS.

		DATE: 04/08/16
DESCRIPTION: 16-Pin, 150mil Wide QSOP		
PACKAGE CODE: Q (Q16)		
DOCUMENT CONTROL #: PD-1201	REVISION: H	

16-0056

PI3B3257

Packaging Mechanical: 16-SOIC (W)

SYMBOLS	MIN.	NOM.	MAX.
A	—	—	1.75
A1	0.10	—	0.25
A2	1.00	—	—
b	0.31	—	0.51
c	0.10	—	0.25
D	9.80	9.90	10.0
E	5.80	6.00	6.20
E1	3.80	3.90	4.00
e	1.27 BSC		
L	0.40	—	1.27
h	0.15	—	0.50
θ°	0	—	8

SEATING PLANE

NOTES:

1. ALL DIMENSIONS IN MILLIMETERS. ANGLES IN DEGREES.
2. JEDEC OUTLINE : MS-012 AC
3. DIMENSIONS DOES NOT INCLUDE MOLD FLASH, PROTRUSIONS OR GATE BURRS.
4. THE MIN. DIMENSION OF A2 AND h ARE OUT OF JEDEC SPEC.

DATE: 06/30/16

DIODES **PERICOM**
INCORPORATED ENABLING SERIAL CONNECTIVITY

DESCRIPTION: 16-Pin, 150mil Wide SOIC

PACKAGE CODE: W

DOCUMENT CONTROL #: PD-1004

REVISION: G

16-0145

PI3B3257

Packaging Mechanical: 16-TSSOP (L)

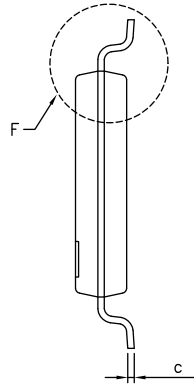
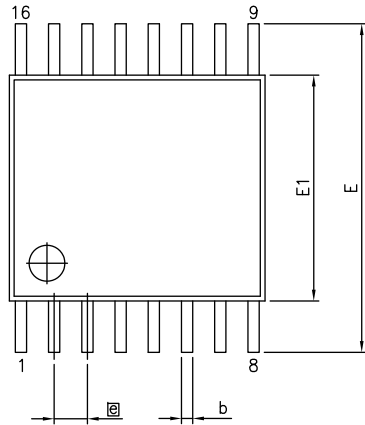

SYMBOLS	MIN.	NOM.	MAX.
A	—	—	1.20
A1	0.05	—	0.15
A2	0.80	1.00	1.05
b	0.19	—	0.30
c	0.09	—	0.20
D	4.90	5.00	5.10
E1	4.30	4.40	4.50
E	6.20	6.40	6.60
\square e	0.65 BSC		
L1	1.00 REF		
L	0.45	0.60	0.75
S	0.20	—	—
θ	0°	—	8°

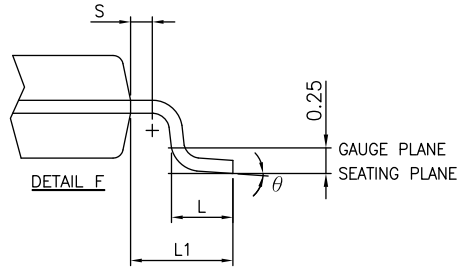
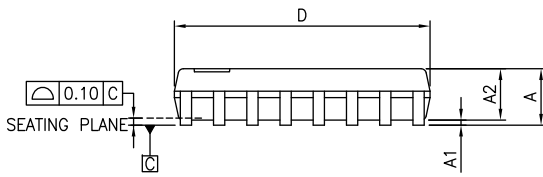

NOTES:

1. ALL DIMENSIONS IN MILLIMETERS. ANGLES IN DEGREES.
2. JEDEC MO-153F
3. DIMENSIONS DOES NOT INCLUDE MOLD FLASH, PROTRUSIONS OR GATE BURRS.

		DATE: 03/24/16
DESCRIPTION: 16-Pin, 173mil Wide TSSOP		
PACKAGE CODE: L (L16)		
DOCUMENT CONTROL #: PD-1310	REVISION: G	

16-0061

PI3B3257

Packaging Mechanical: 16-UQFN (ZHD)

Top View: Shows overall dimensions D and E, and the PIN1 Index Area.

Bottom View: Shows pin locations N1 through N16, dimensions D1, E1, and e.

Side View: Shows dimensions A, A1, and A3.

RECOMMENDED LAND PATTERN(unit:mm): Shows a 3x3 grid of pads with dimensions 0.70x16, 1.60, 1.60, 16X0.27, 2.90, and 0.50BSC.

PKG. DIMENSIONS(MM)		
SYMBOL	Min	Max
A	0.50	0.65
A1	0.00	0.05
A3	0.15 REF	
D	2.90	3.10
E	2.90	3.10
D1	1.60	1.90
E1	1.60	1.90
b	0.18	0.30
e	0.50 BSC	
L	0.25	0.55

Note:
1. Comply with MO-248E, except 'L' MIN and 'L' 'D1' 'E1' MAX

DIODES PERICOM INCORPORATED	DATE: 07/27/16
DESCRIPTION: 16-Pin, UQFN, 3X3	
PACKAGE CODE: ZHD(ZHD16)	
DOCUMENT CONTROL#: PD-2209	REVISION: --

16-0092

For latest package info.

please check: <http://www.diodes.com/design/support/packaging/pericom-packaging/packaging-mechanicals-and-thermal-characteristics/>

Ordering Information

Ordering Code	Packaging Code	Package Description
PI3B3257QEX	Q	16-pin, 150 mil wide (QSOP)
PI3B3257WEX	W	16-pin, 150-mil wide (SOIC)
PI3B3257LEX	L	16-pin, 173 mil wide (TSSOP)
PI3B3257ZHDEX	ZHD	16-pin, 3x3 (UQFN)

Notes:

- EU Directive 2002/95/EC (RoHS), 2011/65/EU (RoHS 2) & 2015/863/EU (RoHS 3) compliant. All applicable RoHS exemptions applied.
- See <http://www.diodes.com/quality/lead-free/> for more information about Diodes Incorporated's definitions of Halogen- and Antimony-free, "Green" and Lead-free. Thermal characteristics can be found on the company web site at www.diodes.com/design/support/packaging/
- E = Pb-free and Green
- X suffix = Tape/Reel

IMPORTANT NOTICE

DIODES INCORPORATED MAKES NO WARRANTY OF ANY KIND, EXPRESS OR IMPLIED, WITH REGARDS TO THIS DOCUMENT, INCLUDING, BUT NOT LIMITED TO, THE IMPLIED WARRANTIES OF MERCHANTABILITY AND FITNESS FOR A PARTICULAR PURPOSE (AND THEIR EQUIVALENTS UNDER THE LAWS OF ANY JURISDICTION).

Diodes Incorporated and its subsidiaries reserve the right to make modifications, enhancements, improvements, corrections or other changes without further notice to this document and any product described herein. Diodes Incorporated does not assume any liability arising out of the application or use of this document or any product described herein; neither does Diodes Incorporated convey any license under its patent or trademark rights, nor the rights of others. Any Customer or user of this document or products described herein in such applications shall assume all risks of such use and will agree to hold Diodes Incorporated and all the companies whose products are represented on Diodes Incorporated website, harmless against all damages.

Diodes Incorporated does not warrant or accept any liability whatsoever in respect of any products purchased through unauthorized sales channel.

Should Customers purchase or use Diodes Incorporated products for any unintended or unauthorized application, Customers shall indemnify and hold Diodes Incorporated and its representatives harmless against all claims, damages, expenses, and attorney fees arising out of, directly or indirectly, any claim of personal injury or death associated with such unintended or unauthorized application.

Products described herein may be covered by one or more United States, international or foreign patents pending. Product names and markings noted herein may also be covered by one or more United States, international or foreign trademarks.

This document is written in English but may be translated into multiple languages for reference. Only the English version of this document is the final and definitive format released by Diodes Incorporated.

LIFE SUPPORT

Diodes Incorporated products are specifically not authorized for use as critical components in life support devices or systems without the express written approval of the Chief Executive Officer of Diodes Incorporated. As used herein:

- A. Life support devices or systems are devices or systems which:
 - 1. are intended to implant into the body, or
 - 2. support or sustain life and whose failure to perform when properly used in accordance with instructions for use provided in the labeling can be reasonably expected to result in significant injury to the user.
- B. A critical component is any component in a life support device or system whose failure to perform can be reasonably expected to cause the failure of the life support device or to affect its safety or effectiveness.

Customers represent that they have all necessary expertise in the safety and regulatory ramifications of their life support devices or systems, and acknowledge and agree that they are solely responsible for all legal, regulatory and safety-related requirements concerning their products and any use of Diodes Incorporated products in such safety-critical, life support devices or systems, notwithstanding any devices- or systems-related information or support that may be provided by Diodes Incorporated. Further, Customers must fully indemnify Diodes Incorporated and its representatives against any damages arising out of the use of Diodes Incorporated products in such safety-critical, life support devices or systems.

Copyright © 2016, Diodes Incorporated
www.diodes.com

Looking for pricing, stock, or lifecycle information?

Click below to explore more details on WIN SOURCE:

 [View PI3B3257Q on WIN SOURCE](#)

 [Diodes Incorporated](#) Information

Optimize Your Supply Chain with WIN SOURCE Solutions

-  Global Sourcing Solution
-  Obsolete Management
-  Cost Control Management
-  Shortage Management
-  Alternative Solution
-  Excess Inventory Management