



**THE DATASHEET OF
ADN2892ACPZ-RL7**



FEATURES

Input sensitivity: 3.5 mV p-p
70 ps rise/fall times
CML outputs: 750 mV p-p differential
Bandwidth selectable for multirate 1×/2×/4× FC modules
Optional LOS output inversion
Programmable LOS detector: 3.5 mV to 35 mV
Rx signal strength indicator (RSSI)
 SFF-8472-compliant average power measurement
Single-supply operation: 3.3 V
Low power dissipation: 160 mW
Available in space-saving, 3 mm × 3 mm, 16-lead LFCSP
Extended temperature range: -40°C to +95°C
SFP reference design available

APPLICATIONS

1×, 2×, and 4× FC transceivers
SFP/SFF/GBIC optical transceivers
GbE transceivers
Backplane receivers

GENERAL DESCRIPTION

The **ADN2892** is a 4.25 Gbps limiting amplifier with integrated loss of signal (LOS) detection circuitry and a received signal strength indicator (RSSI). This part is optimized for Fibre Channel (FC) and Gigabit Ethernet (GbE) optoelectronic conversion applications. The **ADN2892** has a differential input sensitivity of 3.5 mV p-p and accepts up to a 2.0 V p-p differential input overload voltage. The **ADN2892** has current mode logic (CML) outputs with controlled rise and fall times.

The **ADN2892** has a selectable low-pass filter with a -3 dB cutoff frequency of 1.5 GHz. By setting BW_SEL to Logic 0, the filter can limit the relaxation oscillation of a low cost CD laser used in a legacy 1 Gbps FC transmitter. The limited BW also reduces the rms noise and in turn improves the receiver optical sensitivity for a lower data rate application, such as 1× FC and GbE.

By monitoring the bias current through a photodiode, the on-chip RSSI detector measures the average power received with 2% typical linearity over the entire valid input range of the photodiode. The on-chip RSSI detector facilitates SFF-8472-compliant optical transceivers by eliminating the need for external RSSI detector circuitry.

Additional features include a programmable loss-of-signal (LOS) detector and output squelch. The **ADN2892** is available in a 3 mm × 3 mm, 16-lead LFCSP.

FUNCTIONAL BLOCK DIAGRAM

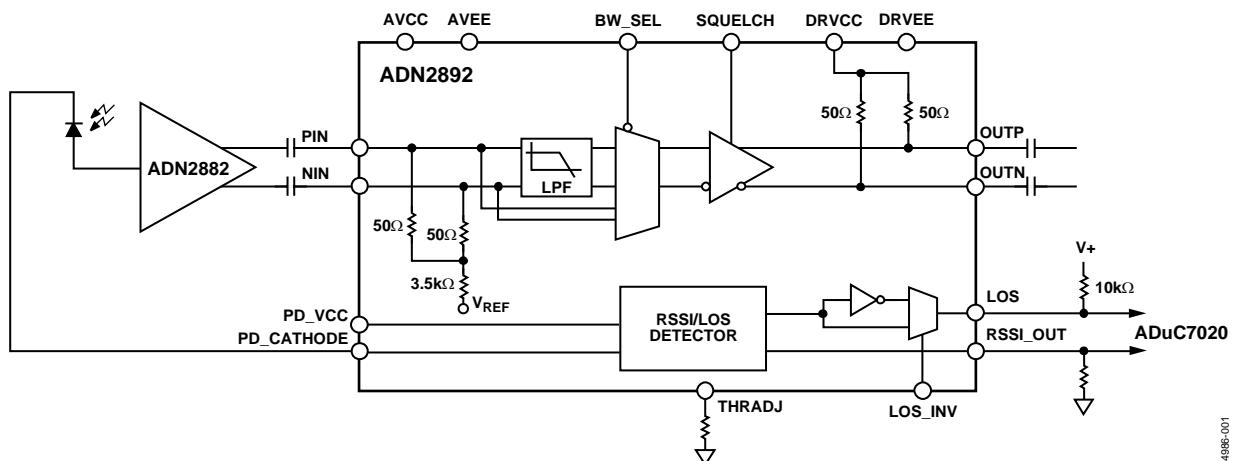

Figure 1. RSSI Function Capable—Applications Setup Block Diagram

Rev. C

[Document Feedback](#)

Information furnished by Analog Devices is believed to be accurate and reliable. However, no responsibility is assumed by Analog Devices for its use, nor for any infringements of patents or other rights of third parties that may result from its use. Specifications subject to change without notice. No license is granted by implication or otherwise under any patent or patent rights of Analog Devices. Trademarks and registered trademarks are the property of their respective owners.

One Technology Way, P.O. Box 9106, Norwood, MA 02062-9106, U.S.A.
 Tel: 781.329.4700 ©2005–2017 Analog Devices, Inc. All rights reserved.
 Technical Support www.analog.com

TABLE OF CONTENTS

Features	1	Limiting Amplifier	10
Applications	1	Loss-of-Signal (LOS) Detector	10
General Description	1	Received Signal Strength Indicator (RSSI)	10
Functional Block Diagram	1	Squelch Mode	10
Revision History	2	BW_SEL (Bandwidth Selection) Mode	10
Specifications	3	LOS_INV (Lose of Signal_Invert) Mode	10
Absolute Maximum Ratings	5	Applications Information	11
Thermal Resistance	5	PCB Design Guidelines	11
ESD Caution	5	Pad Coating and Pb-Free Soldering	12
Pin Configuration and Function Descriptions	6	Outline Dimensions	13
Typical Performance Characteristics	7	Ordering Guide	13
Theory of Operation	10		

REVISION HISTORY

3/2017—Rev. B to Rev. C

Changes to Figure 2	6
Changes to Figure 18	11
Updated Outline Dimensions	13
Changes to Ordering Guide	13

2/2014—Rev. A to Rev. B

Changes to Figure 2	6
---------------------------	---

7/2013—Rev. 0 to Rev. A

Change to Output Voltage Swing Parameter, Table 1	3
Changes to Figure 2	6
Updated Outline Dimensions	13
Changes to Ordering Guide	13

4/2005—Revision 0: Initial Version

SPECIFICATIONS

Test Conditions: $V_{CC} = 2.9\text{ V to }3.6\text{ V}$, $V_{EE} = 0\text{ V}$, $T_A = -40^\circ\text{C to }+95^\circ\text{C}$, unless otherwise noted.

Table 1.

Parameter	Min	Typ	Max	Unit	Test Conditions/Comments
QUANTIZER DC CHARACTERISTICS					
Input Voltage Range	$V_{CC} - 1.2$		$V_{CC} - 0.2$	V	At PIN or NIN, dc-coupled
Input Common Mode	2.1		2.7	V	DC-coupled
Peak-to-Peak Differential Input Range			2.0	V p-p	PIN – NIN, ac-coupled
Input Sensitivity	6.6	3.5		mV p-p	PIN – NIN, BER $\leq 1 \times 10^{-10}$
Input Offset Voltage		100		μV	
Input RMS Noise		235		$\mu\text{V rms}$	
Input Resistance		50		Ω	Single-ended
Input Capacitance		0.65		pF	
QUANTIZER AC CHARACTERISTICS					
Input Data Rate	1.0		4.25	Gbps	
Small Signal Gain		51		dB	Differential
S11		-10		dB	Differential, $f < 4.25\text{ GHz}$
S22		-10		dB	Differential, $f < 4.25\text{ GHz}$
Random Jitter		3.0	3.9	ps rms	Input $\geq 10\text{ mV p-p}$, 4x FC, K28.7 pattern
Deterministic Jitter		10	21.0	ps p-p	Input $\geq 10\text{ mV p-p}$, 4x FC, K28.5 pattern
Low Frequency Cutoff		30		kHz	
Power Supply Rejection		45		dB	100 kHz $< f < 10\text{ MHz}$
LOSS OF SIGNAL DETECTOR (LOS)					
LOS Assert Level	2.9	3.5	4.8	mV p-p	$R_{THRADJ} = 100\text{ k}\Omega$
	22.4	35	55.0	mV p-p	$R_{THRADJ} = 1\text{ k}\Omega$
Electrical Hysteresis	2.5	5.0		dB	1.0 Gbps, PRBS $2^{23} - 1$
	2.8	5.0		dB	4x FC, PRBS $2^{23} - 1$
LOS Assert Time		950		ns	DC-coupled
LOS Deassert Time		62		ns	DC-coupled
RSSI					
Input Current Range	5		1000	μA	
RSSI Output Linearity		2		%	$5\text{ }\mu\text{A} \leq I_{IN} \leq 1000\text{ }\mu\text{A}$
Gain		1.0		mA/mA	$I_{RSSI}/I_{PD_CATHODE}$
Offset		145		nA	
Compliance Voltage (At PD_CATHODE)	$V_{CC} - 0.4$			V	$I_{PD_CATHODE} = 5\text{ }\mu\text{A}$
	$V_{CC} - 0.9$			V	$I_{PD_CATHODE} = 1000\text{ }\mu\text{A}$
BW_SEL (BANDWIDTH SELECTION)					
Channel Bandwidth		1.5		GHz	-3 dB cutoff frequency of the on-chip, two-pole, low-pass filter, when BW_SEL = 0
POWER SUPPLIES					
V_{CC}	2.9	3.3	3.6	V	
I_{CC}		48	54	mA	
OPERATING TEMPERATURE RANGE					
	-40	+25	+95	$^\circ\text{C}$	T_{MIN} to T_{MAX}
CML OUTPUT CHARACTERISTICS					
Output Impedance		50		Ω	Single-ended
Output Voltage Swing	600	750	940	mV p-p	Differential
Output Rise and Fall Time		70	103	ps	20% to 80%

Parameter	Min	Typ	Max	Unit	Test Conditions/Comments
LOGIC INPUTS (SQUELCH, LOS_INV, AND BW_SEL)					
V_{IH} , Input High Voltage	2.0			V	
V_{IL} , Input Low Voltage			0.8	V	
Input Current (SQUELCH, LOS_INV)			39	μ A	I_{INH} , $V_{IN} = 2.4$ V, 100 k Ω pull-down, on-chip resistor
Input Current (BW_SEL)			-38	μ A	I_{INL} , $V_{IN} = 0.0$ V, 100 k Ω pull-up, on-chip resistor
LOGIC OUTPUTS (LOS)					
V_{OH} , Output High Voltage	2.4			V	Open drain output, 4.7 k Ω – 10 k Ω pull-up resistor to VCC
V_{OL} , Output Low Voltage			0.4	V	Open drain output, 4.7 k Ω – 10 k Ω pull-up resistor to VCC

ABSOLUTE MAXIMUM RATINGS

Table 2.

Parameter	Rating
Power Supply Voltage	4.2 V
Minimum Voltage (All Inputs and Outputs)	VEE – 0.4 V
Maximum Voltage (All Inputs and Outputs)	VCC + 0.4 V
Storage Temperature	–65°C to +150°C
Operating Temperature Range	–40°C to +95°C
Production Soldering Temperature	J-STD-20
Junction Temperature	125°C

Stresses at or above those listed under Absolute Maximum Ratings may cause permanent damage to the product. This is a stress rating only; functional operation of the product at these or any other conditions above those indicated in the operational section of this specification is not implied. Operation beyond the maximum operating conditions for extended periods may affect product reliability.

THERMAL RESISTANCE

θ_{JA} is specified for 4-layer PCB with exposed paddle soldered to GND.

Table 3.

Package Type	θ_{JA}	Unit
3 mm × 3 mm, 16-lead LFCSP	28	°C/W

ESD CAUTION



ESD (electrostatic discharge) sensitive device. Charged devices and circuit boards can discharge without detection. Although this product features patented or proprietary protection circuitry, damage may occur on devices subjected to high energy ESD. Therefore, proper ESD precautions should be taken to avoid performance degradation or loss of functionality.

PIN CONFIGURATION AND FUNCTION DESCRIPTIONS

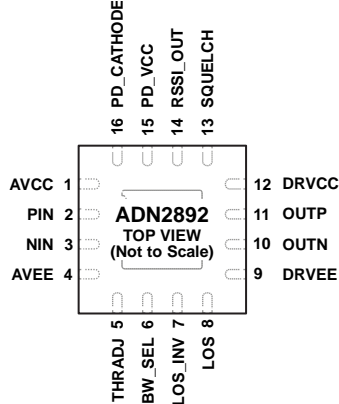

NOTES

1. THERE IS AN EXPOSED PAD ON THE BOTTOM OF THE PACKAGE THAT MUST BE CONNECTED TO THE GND PLANE WITH FILLED VIAS.

04886-002

Figure 2. Pin Configuration

Table 4. Pin Function Descriptions

Pin No.	Mnemonic	I/O Type ¹	Description
1	AVCC	P	Analog Power Supply.
2	PIN	AI	Differential Data Input, Positive Port, 50 Ω On-Chip Termination.
3	NIN	AI	Differential Data Input, Negative Port, 50 Ω On-Chip Termination.
4	AVEE	P	Analog Ground.
5	THRADJ	AO	LOS Threshold Adjust Resistor.
6	BW_SEL	DI	With one 100 kΩ on-chip, pull-up resistor, BW_SEL = 0 for 1×/2× FC, BW_SEL = 1 for 4× FC.
7	LOS_INV	DI	With one 100 kΩ on-chip, pull-down resistor, LOS_INV = 1 inverts the LOS output to be active low for SFF.
8	LOS	DO	LOS Detector Output, Open Collector.
9	DRVVEE	P	Output Buffer Ground.
10	OUTN	DO	Differential Data Output, CML, Negative Port, 50 Ω, On-Chip Termination.
11	OUTP	DO	Differential Data Output, CML, Positive Port, 50 Ω, On-Chip Termination.
12	DRVCC	P	Output Buffer Power Supply.
13	SQUELCH	DI	Disable Outputs, 100 kΩ On-Chip, Pull-Down Resistor.
14	RSSI_OUT	AO	Average Current Output.
15	PD_VCC	P	Power Input for RSSI Measurement.
16	PD_CATHODE	AO	Photodiode Bias Voltage.
Exposed Pad	Pad	P	Connect to Ground.

¹ P = power; DI = digital input; DO = digital output; AI = analog input; and AO = analog output.

TYPICAL PERFORMANCE CHARACTERISTICS

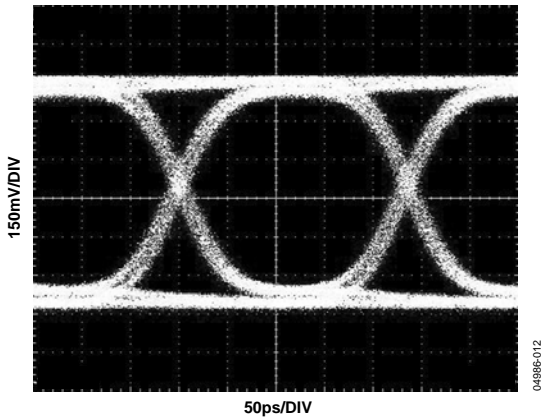

Figure 3. Eye of ADN2892 at 25°C, 4.25 Gbps, and 10 mV Input

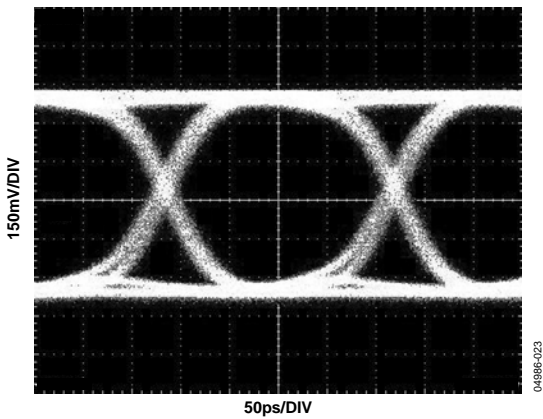

Figure 4. Eye of ADN2892 at 95°C, 4.25 Gbps, and 10 mV Input

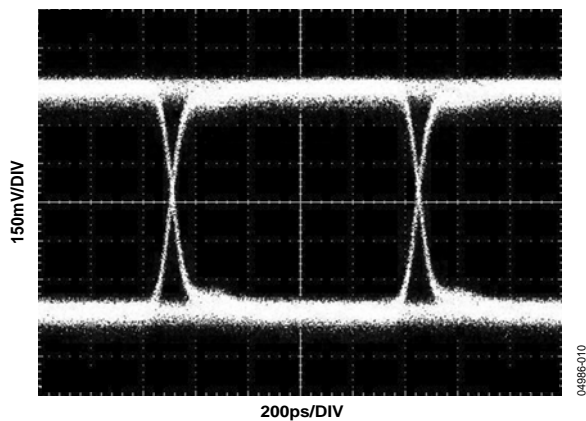

Figure 5. Eye of ADN2892 at 25°C, 1.063 Gbps, and 10 mV Input (BW_SEL = 0)

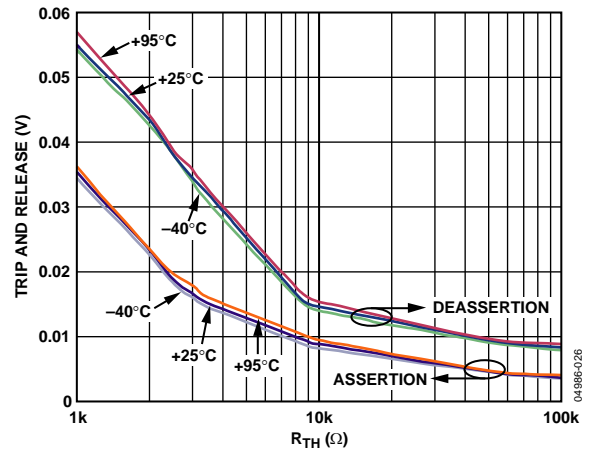

Figure 6. LOS Trip and Release vs. R_{TH} at 4.25 Gbps

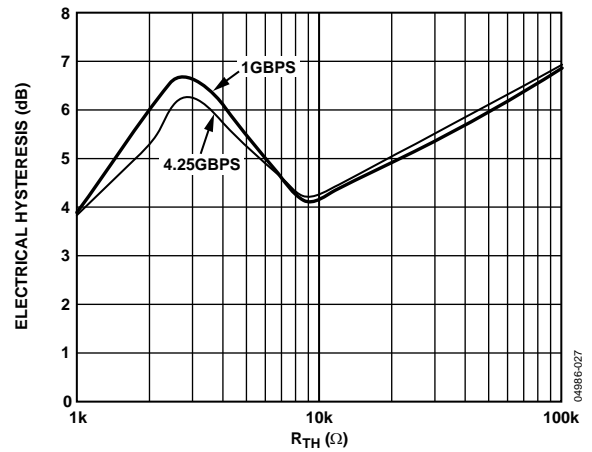

Figure 7. LOS Electrical Hysteresis vs. R_{TH} at 25°C

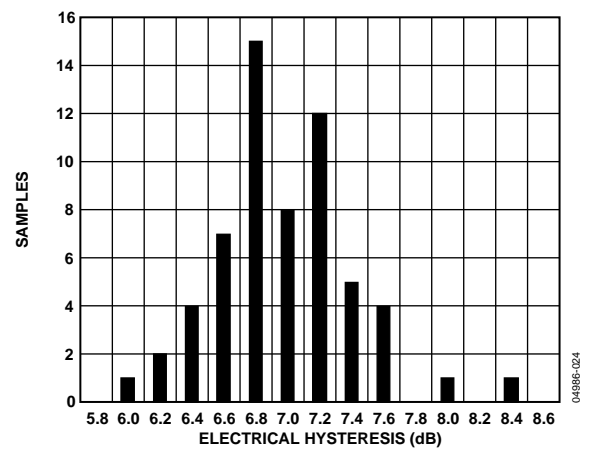

Figure 8. Sample Lot Distribution—Worst-Case Condition: Conditions = 4.25 Gbps, 100 kΩ at -40°C, 3.6 V

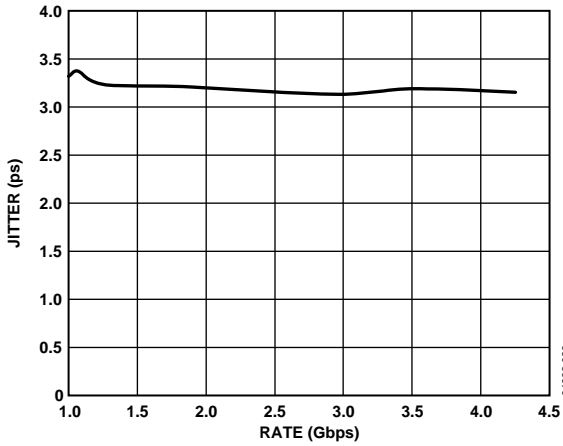

Figure 9. Random Jitter vs. Data Rate

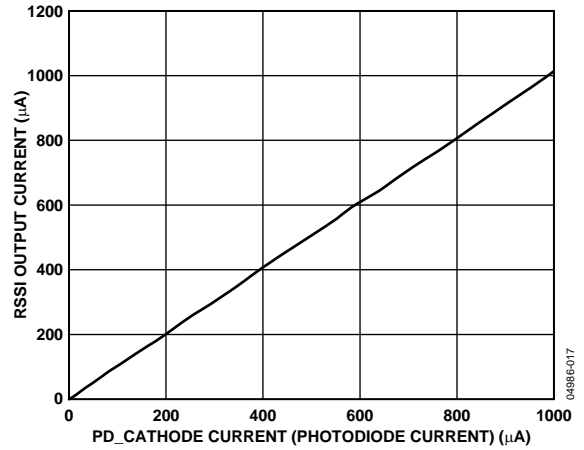

Figure 12. RSSI Output vs. Average Photodiode Current

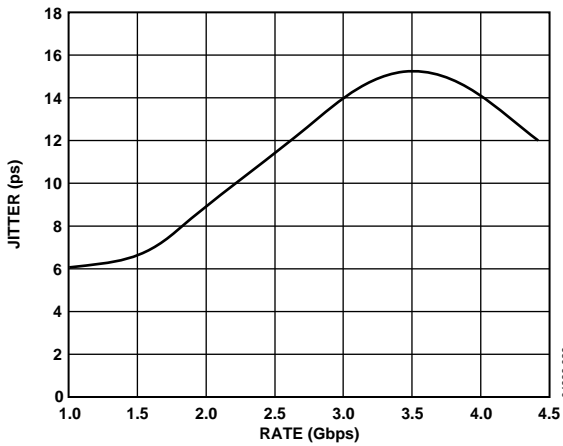

Figure 10. Deterministic Jitter vs. Data Rate

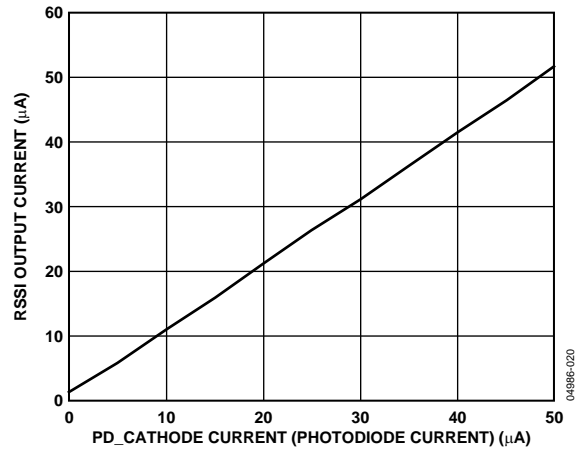

Figure 13. RSSI Output vs. Average Photodiode Current (Zoomed)

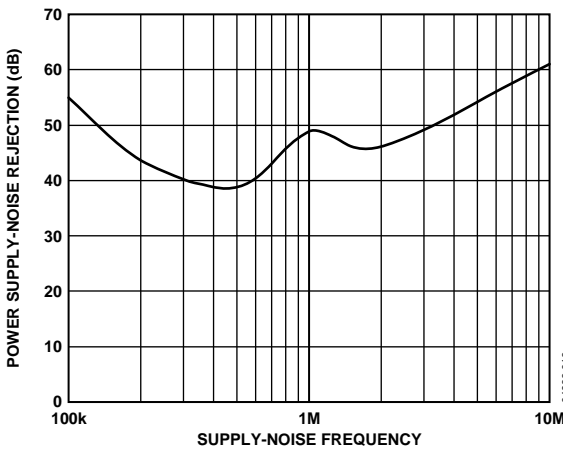

Figure 11. PSRR vs. Supply-Noise Frequency

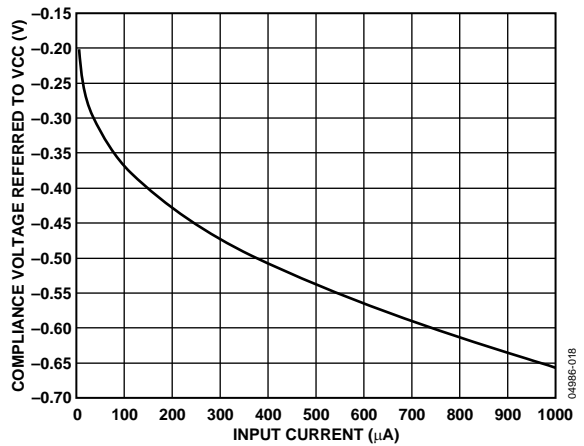

Figure 14. PD_CATHODE Compliance Voltage vs. Input Current RSSI (Refer to VCC)

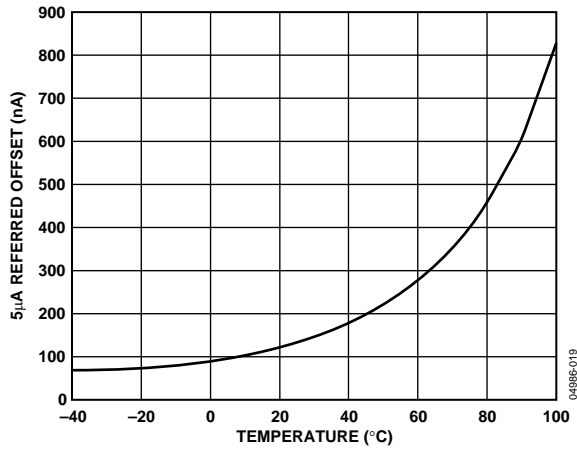

Figure 15. RSSI Offset—Difference Between Measured RSSI Output and PD_CATHODE (Input) Current of 5 µA

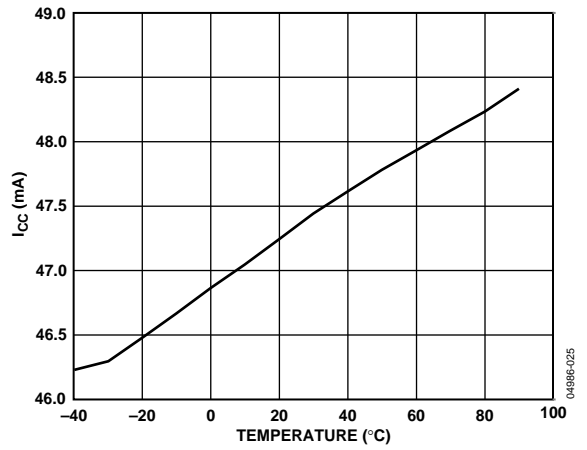

Figure 17. ADN2892 I_{CC} Current vs. Temperature

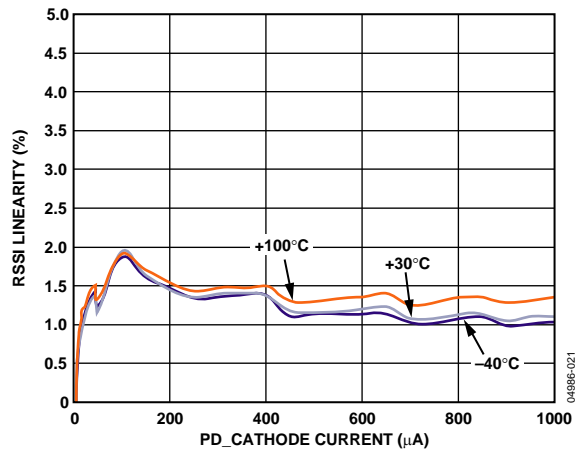

Figure 16. RSSI Linearity % vs. PD_CATHODE Current

THEORY OF OPERATION

LIMITING AMPLIFIER

Input Buffer

The ADN2892 limiting amplifier provides differential inputs (PIN/NIN), each with a single-ended, on-chip 50 Ω termination. The amplifier can accept either dc-coupled or ac-coupled signals; however, an ac-coupled signal is recommended. Using a dc-coupled signal, the amplifier needs a nominal $V_{CC} - 0.7$ V common-mode voltage and ± 0.5 V headroom. If the input common-mode voltage is 2.4 V, the available headroom is reduced down to ± 0.3 V.

The ADN2892 limiting amplifier is a high gain device. It is susceptible to dc offsets in the signal path. The pulse width distortion presented in the NRZ data or a distortion generated by the TIA may appear as dc offset or a corrupted signal to the ADN2892 inputs. An internal offset correction loop can compensate for certain levels of offset.

CML Output Buffer

The ADN2892 provides differential CML outputs, OOUTP and OOUTN. Each output has an internal 50 Ω termination to VCC.

LOSS-OF-SIGNAL (LOS) DETECTOR

The on-chip LOS circuit drives LOS to logic high when the input signal level falls below a user-programmable threshold. The threshold level can be set anywhere from 3.5 mV p-p to 35 mV p-p typical by a resistor connected between the THRADJ pin and VEE. See Figure 6 and Figure 7 for the LOS threshold vs. THRADJ. The ADN2892 LOS circuit has an electrical hysteresis greater than 2.5 dB to prevent chatter at the LOS signal. The LOS output is an open-collector output that must be pulled up externally with a 4.7 k Ω to 10 k Ω resistor.

RECEIVED SIGNAL STRENGTH INDICATOR (RSSI)

The ADN2892 has an on-chip, RSSI circuit. By monitoring the current supplied to the photodiode, the RSSI circuit provides an accurate, average power measurement. The output of the RSSI is a current that is directly proportional to the average amount of PIN photodiode current. Placing a resistor between the RSSI_OUT pin and GND converts the current to a GND referenced voltage. This function eliminates the need for external RSSI circuitry for SFF-8472-compliant optical receivers. For more information, see Figure 12 to Figure 16.

Connect the PD_VCC, PD_CATHODE, and RSSI_OUT pins to AVCC to disable the RSSI feature.

SQUELCH MODE

Driving the SQUELCH input to logic high disables the limiting amplifier outputs. Using LOS output to drive the SQUELCH input, the limiting amplifier outputs stop toggling anytime a signal input level to the limiting amplifier drops below the programmed LOS threshold.

The SQUELCH pin has a 100 k Ω , internal pull-down resistor.

BW_SEL (BANDWIDTH SELECTION) MODE

Driving the BW_SEL input signal to logic high, the amplifier provides a 3.8 GHz bandwidth. Driving the BW_SEL input signal to logic low, the amplifier accepts input signals through a 1.5 GHz, 2-pole, low-pass filter that improves receiving sensitivity.

The low-pass filter reduces the possible relaxation oscillation of low speed, low cost laser source by limiting the input signal bandwidth.

The BW_SEL pin has a 100 k Ω , on-chip pull-up resistor. Setting the BW_SEL pin open disables the low-pass filter.

LOS_INV (LOSE OF SIGNAL_INVERT) MODE

Some applications, such as SFF, need the LOS assertion and deassertion voltage reversed. When the LOS_INV pin is pulled to logic high, the LOS output assertion is pulled down to electrical low.

The LOS_INV pin has a 100 k Ω on-chip, pull-down resistor.

APPLICATIONS INFORMATION

PCB DESIGN GUIDELINES

Proper RF PCB design techniques must be used to ensure optimal performance.

Output Buffer Power Supply and Ground Planes

Pin 9 (DRVEE) and Pin 12 (DRVCC) are the power supply and ground pins that provide current to the differential output buffer. To reduce possible series inductance, Pin 9, which is the ground return of the output buffer, should connect to ground directly. If the ground plane is an internal plane and connections to the ground plane are vias, multiple vias in parallel to ground can reduce series inductance.

Similarly, to reduce the possible series inductance, Pin 12, which supplies power to the high speed differential OUTP/OUTN output buffer, should connect to the power plane directly. If the power plane is an internal plane and connections to the power plane are vias, multiple vias in parallel can reduce the series inductance, especially on Pin 12. See Figure 18 for the recommended connections.

The exposed pad should connect to the GND plane using filled vias so that solder does not leak through the vias during reflow. Using filled vias in parallel under the package greatly reduces the thermal resistance and enhances the reliability of the connectivity of the exposed pad to the GND plane during reflow.

To reduce power supply noise, a 10 μF electrolytic decoupling capacitor between power and ground should be close to where the 3.3 V supply enters the PCB. The other 0.1 μF and 1 nF ceramic chip decoupling capacitors should be close to the VCC and VEE pins to provide optimal supply decoupling and a shorter current return loop.

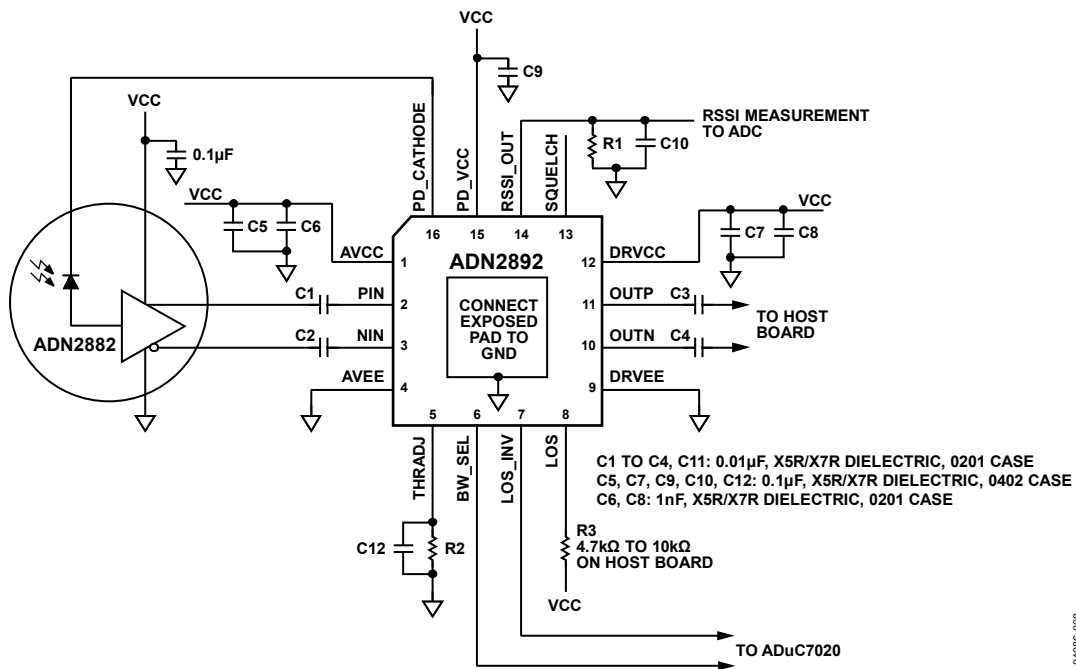

Figure 18. Typical ADN2892 Applications Circuit

04986-008

PCB Layout

Figure 19 shows the recommended PCB layout. The 50 Ω transmission lines are the traces that bring the high frequency input and output signals (PIN, NIN, OUTP, and OUTN) from a terminated source to a terminated load with minimum reflection. To avoid a signal skew between the differential traces, each differential PIN/NIN and OUTP/OUTN pair should have matched trace lengths from a differential source to a differential load. C1, C2, C3, and C4 are ac coupling capacitors in series with the high speed, signal input/output paths. To minimize the possible mismatch, the ac coupling capacitor pads should be the same width as the 50 Ω transmission line trace width. To reduce supply noise, a 1 nF decoupling capacitor should be placed as close as possible to the VCC pins on the same layer and not through vias. A 0.1 μF decoupling capacitor can be placed on the bottom of the PCB directly underneath the 1 nF capacitor. All high speed, CML outputs have internal 50 Ω resistor termination between the output pin and VCC. The high speed inputs, PIN and NIN, also have the internal 50 Ω termination to an internal reference voltage.

As with any high speed, mixed-signal design, keep all high speed digital traces away from sensitive analog nodes.

Soldering Guidelines for the LFCSP

The lands on the 16-lead LFCSP are rectangular. The PCB pad for these should be 0.1 mm longer than the package land length and 0.05 mm wider than the package land width. The land should be centered on the pad. This ensures that the solder joint size is maximized. The bottom of the LFCSP has a central exposed pad. The pad on the printed circuit board should be at least as large as the exposed pad. Users must connect the exposed pad to VEE using filled vias so that solder does not leak through the vias during reflow. This ensures a solid connection from the exposed pad to VEE.

PAD COATING AND PB-FREE SOLDERING

Table 5.

Pad Coating	Matt-Tin
Pb-Free Reflow Portfolio	J-STD-20B

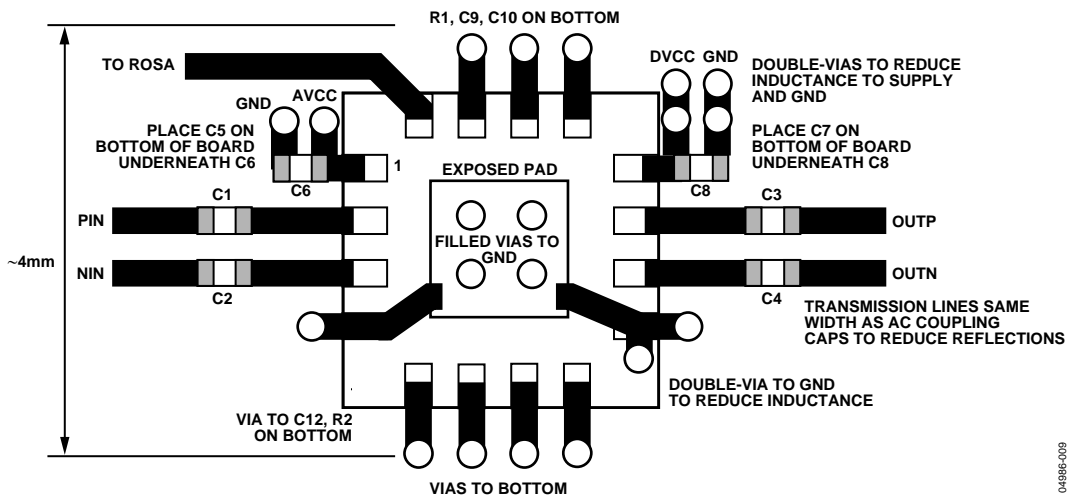
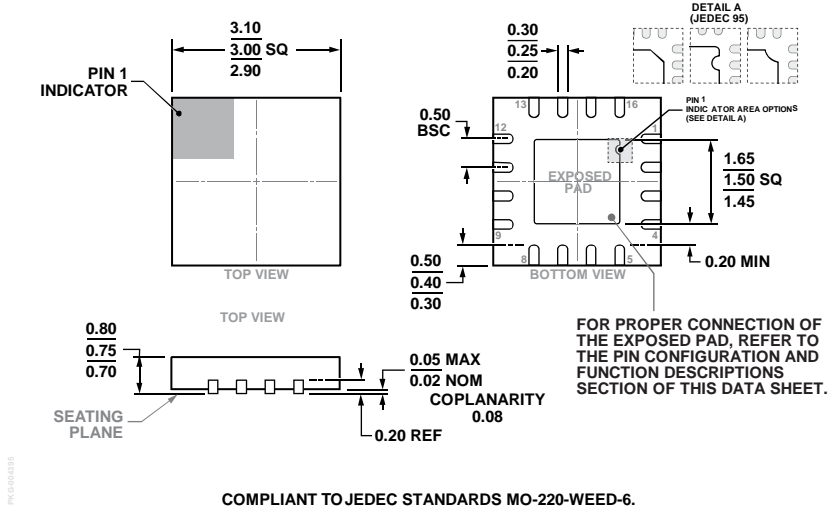

Figure 19. Recommended ADN2892 PCB Layout (Top View)

OUTLINE DIMENSIONS



COMPLIANT TO JEDEC STANDARDS MO-220-WEED-6.

Figure 20. 16-Lead Lead Frame Chip Scale Package [LFCSP]
 3 mm × 3 mm Body and 0.75 mm Package Height
 (CP-16-27)
 Dimensions shown in millimeters

ORDERING GUIDE

Model ¹	Temperature Range	Package Description	Package Option	Branding
ADN2892ACPZ-500RL7	-40°C to +95°C	16-Lead LFCSP, 500 pieces	CP-16-27	F05
ADN2892ACPZ-RL7	-40°C to +95°C	16-Lead LFCSP, 1,500 pieces	CP-16-27	F05
EVAL-ADN2892EBZ		Evaluation Board		

¹ Z = RoHS-Compliant Part.

NOTES

NOTES

NOTES

Looking for pricing, stock, or lifecycle information?

Click below to explore more details on WIN SOURCE:

 [View ADN2892ACPZ-RL7 on WIN SOURCE](#)

 [Analog Devices Inc. Information](#)

Optimize Your Supply Chain with WIN SOURCE Solutions

-  Global Sourcing Solution
-  Obsolete Management
-  Cost Control Management
-  Shortage Management
-  Alternative Solution
-  Excess Inventory Management