

**FEATURES**

- ARM720T Processor
  - ARM7TDMI CPU
  - 8 KB of four-way set-associative cache
  - MMU with 64-entry TLB
  - Thumb code support enabled
- Ultra low power
  - 90 mW at 74 MHz typical
  - 30 mW at 18 MHz typical
  - 10 mW in the Idle State
  - <1 mW in the Standby State
- Advanced audio decoder/decompression capability
  - Supports bit streams with adaptive bit rates
  - Allows for support of multiple audio decompression algorithms (MP3, WMA, AAC, ADPCM, Audible, etc.)



**High-performance,  
Low-power, System-on-chip  
with Enhanced  
Digital Audio Interface**

**OVERVIEW**

The Maverick™ EP7309 is designed for ultra-low-power applications such as digital music players, internet appliances, smart cellular phones or any hand-held device that features the added capability of digital audio decompression. The core-logic functionality of the device is built around an ARM720T processor with 8 KB of four-way set-associative unified cache and a write buffer. Incorporated into the ARM720T is an enhanced memory management unit (MMU) which allows for support of sophisticated operating systems like Microsoft® Windows® CE and Linux®.

(cont.)

(cont.)

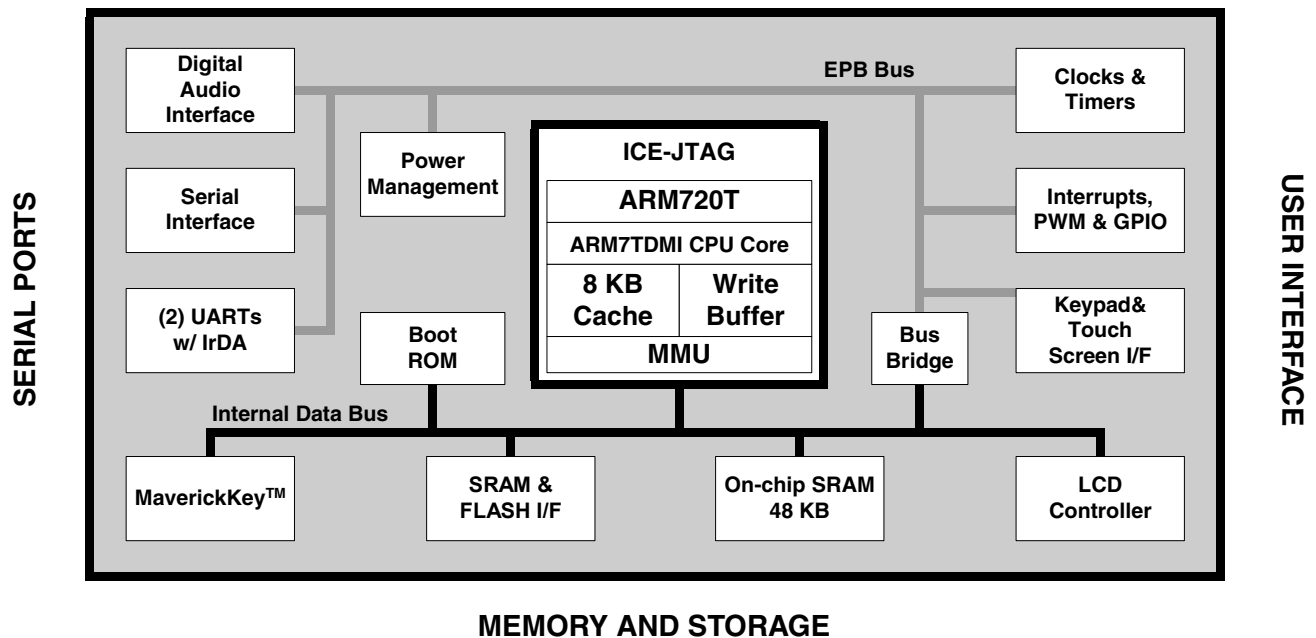
**BLOCK DIAGRAM**

---

## FEATURES (cont)

- Dynamically programmable clock speeds of 18, 36, 49, and 74 MHz
- 48 KB of on-chip SRAM
- MaverickKey™ IDs
  - 32-bit unique ID can be used for SDMI compliance
  - 128-bit random ID
- LCD controller
  - Interfaces directly to a single-scan panel monochrome STN LCD
  - Interfaces to a single-scan panel color STN LCD with minimal external glue logic
- Full JTAG boundary scan and Embedded ICE® support
- Integrated Peripheral Interfaces
  - 8/32/16-bit SRAM/FLASH/ROM Interface
  - Digital Audio Interface providing glueless interface to low-power DACs, ADCs and CODECs
  - Two Synchronous Serial Interfaces (SS11, SS12)
  - CODEC Sound Interface
- 8x8 Keypad Scanner
- 27 General Purpose Input/Output pins
- Dedicated LED flasher pin from the RTC
- Internal Peripherals
  - Two 16550 compatible UARTs
  - IrDA Interface
  - Two PWM Interfaces
  - Real-time Clock
  - Two general purpose 16-bit timers
  - Interrupt Controller
  - Boot ROM
- Package
  - 208-Pin LQFP
  - 256-Ball PBGA
  - 204-Ball TFBGA
- The fully static EP7309 is optimized for low power dissipation and is fabricated on a 0.25 micron CMOS process

---

## OVERVIEW (cont.)

The EP7309 is designed for ultra-low-power operation. Its core operates at only 2.5 V, while its I/O has an operation range of 2.5 V–3.3 V. The device has three basic power states: operating, idle and standby.

MaverickKey unique hardware programmed IDs are a solution to the growing concern over secure web content and commerce. With Internet security playing an important role in the delivery of digital media such as books or music, traditional software methods are quickly becoming unreliable. The MaverickKey unique IDs provide OEMs with a method of utilizing specific hardware IDs such as those assigned for SDMI (Secure Digital Music Initiative) or any other authentication mechanism.

The EP7309 integrates an interface to enable a direct connection to many low cost, low power, high quality audio converters. In particular, the DAI can directly interface with the Crystal, CS43L41/42/43 low-power audio DACs and the Crystal, CS53L32 low-power ADC. Some of these devices feature digital bass and treble boost, digital volume control and compressor-limiter functions.

Simply by adding desired memory and peripherals to the highly integrated EP7309 completes a low-power system solution. All necessary interface logic is integrated on-chip.

# Table of Contents

<b>FEATURES</b> .....	1
<b>OVERVIEW</b> .....	1
Processor Core - ARM720T .....	6
Power Management .....	6
MaverickKey™ Unique ID .....	6
Memory Interfaces .....	6
Digital Audio Capability .....	6
Universal Asynchronous Receiver/Transmitters (UARTs) .....	6
Digital Audio Interface (DAI) .....	7
CODEC Interface .....	7
SSI2 Interface .....	7
Synchronous Serial Interface .....	8
LCD Controller .....	8
Interrupt Controller .....	8
Real-Time Clock .....	8
PLL and Clocking .....	9
DC-to-DC converter interface (PWM) .....	9
Timers .....	9
General Purpose Input/Output (GPIO) .....	9
Hardware debug Interface .....	9
Internal Boot ROM .....	10
Packaging .....	10
Pin Multiplexing .....	10
System Design .....	11
<b>ELECTRICAL SPECIFICATIONS</b> .....	<b>12</b>
Absolute Maximum Ratings .....	12
Recommended Operating Conditions .....	12
DC Characteristics .....	12
<b>Timings</b> .....	<b>14</b>
Timing Diagram Conventions .....	14
Timing Conditions .....	14
Static Memory .....	15
Static Memory Single Read Cycle .....	16
Static Memory Single Write Cycle .....	17
Static Memory Burst Read Cycle .....	18
Static Memory Burst Write Cycle .....	19
SSI1 Interface .....	20
SSI2 Interface .....	21
LCD Interface .....	22
JTAG Interface .....	23
<b>Packages</b> .....	<b>24</b>
208-Pin LQFP Package Characteristics .....	24
208-Pin LQFP Package Specifications .....	24
208-Pin LQFP Pin Diagram .....	25
208-Pin LQFP Numeric Pin Listing .....	26
204-Ball TFBGA Package Characteristics .....	29
204-Ball TFBGA Package Specifications .....	29
204-Ball TFBGA Pinout (Top View) .....	30

---

204-Ball TFBGA Ball Listing .....	31
256-Ball PBGA Package Characteristics .....	38
256-Ball PBGA Package Specifications .....	38
256-Ball PBGA Pinout (Top View) .....	39
256-Ball PBGA Ball Listing .....	39
JTAG Boundary Scan Signal Ordering .....	43
<b>CONVENTIONS .....</b>	<b>48</b>
Acronyms and Abbreviations .....	48
Units of Measurement .....	48
General Conventions .....	49
Pin Description Conventions .....	49
	49
<b>Ordering Information .....</b>	<b>50</b>
<b>Environmental, Manufacturing, &amp; Handling Information .....</b>	<b>50</b>
<b>Revision History .....</b>	<b>51</b>

## List of Figures

Figure 1. A Maximum EP7309 Based System .....	11
Figure 2. Legend for Timing Diagrams .....	14
Figure 3. Static Memory Single Read Cycle Timing Measurement .....	16
Figure 4. Static Memory Single Write Cycle Timing Measurement .....	17
Figure 5. Static Memory Burst Read Cycle Timing Measurement .....	18
Figure 6. Static Memory Burst Write Cycle Timing Measurement .....	19
Figure 7. SSI1 Interface Timing Measurement .....	20
Figure 8. SSI2 Interface Timing Measurement .....	21
Figure 9. LCD Controller Timing Measurement .....	22
Figure 10. JTAG Timing Measurement .....	23
Figure 11. 208-Pin LQFP Package Outline Drawing .....	24
Figure 12. 208-Pin LQFP (Low Profile Quad Flat Pack) Pin Diagram .....	25
Figure 13. 204-Ball TFBGA Package .....	29
Figure 14. 256-Ball PBGA Package .....	38

## List of Tables

Table 1. Power Management Pin Assignments .....	6
Table 2. Static Memory Interface Pin Assignments .....	6
Table 3. Universal Asynchronous Receiver/Transmitters Pin Assignments .....	7
Table 4. DAI Interface Pin Assignments .....	7
Table 5. CODEC Interface Pin Assignments .....	7
Table 6. SSI2 Interface Pin Assignments .....	7
Table 7. Serial Interface Pin Assignments .....	8
Table 8. LCD Interface Pin Assignments .....	8
Table 9. Keypad Interface Pin Assignments .....	8
Table 10. Interrupt Controller Pin Assignments .....	8
Table 11. Real-Time Clock Pin Assignments .....	9
Table 12. PLL and Clocking Pin Assignments .....	9
Table 13. DC-to-DC Converter Interface Pin Assignments .....	9
Table 14. General Purpose Input/Output Pin Assignments .....	9
Table 15. Hardware Debug Interface Pin Assignments .....	9
Table 16. LED Flasher Pin Assignments .....	9
Table 17. DAI/SSI2/CODEC Pin Multiplexing .....	10
Table 18. Pin Multiplexing .....	10
Table 19. 208-Pin LQFP Numeric Pin Listing .....	26
Table 20. 204-Ball TFBGA Ball Listing .....	31
Table 21. 256-Ball PBGA Ball Listing .....	39
Table 22. JTAG Boundary Scan Signal Ordering .....	43
Table 23. Acronyms and Abbreviations .....	48
Table 24. Unit of Measurement .....	48
Table 25. Pin Description Conventions .....	49

## Processor Core - ARM720T

The EP7309 incorporates an ARM 32-bit RISC microcontroller that controls a wide range of on-chip peripherals. The processor utilizes a three-stage pipeline consisting of fetch, decode and execute stages. Key features include:

- ARM (32-bit) and Thumb (16-bit compressed) instruction sets
- Enhanced MMU for Microsoft Windows CE and other operating systems
- 8 KB of 4-way set-associative cache.
- Translation Look Aside Buffers with 64 Translated Entries

## Power Management

The EP7309 is designed for ultra-low-power operation. Its core operates at only 2.5 V, while its I/O has an operation range of 2.5 V–3.3 V allowing the device to achieve a performance level equivalent to 60 MIPS. The device has three basic power states:

- Operating — This state is the full performance state. All the clocks and peripheral logic are enabled.
- Idle — This state is the same as the Operating State, except the CPU clock is halted while waiting for an event such as a key press.
- Standby — This state is equivalent to the computer being switched off (no display), and the main oscillator shut down. An event such as a key press can wake-up the processor.

Pin Mnemonic	I/O	Pin Description
BATOK	I	Battery ok input
nEXTPWR	I	External power supply sense input
nPWRFL	I	Power fail sense input
nBATCHG	I	Battery changed sense input

Table 1. Power Management Pin Assignments

## MaverickKey™ Unique ID

MaverickKey unique hardware programmed IDs are a solution to the growing concern over secure web content and commerce. With Internet security playing an important role in the delivery of digital media such as books or music, traditional software methods are quickly becoming unreliable. The MaverickKey unique IDs provide OEMs with a method of utilizing specific hardware IDs such as those assigned for SDMI (Secure Digital Music Initiative) or any other authentication mechanism.

Both a specific 32-bit ID as well as a 128-bit random ID is programmed into the EP7309 through the use of laser probing technology. These IDs can then be used to match secure copyrighted content with the ID of the target device the EP7309 is powering, and then deliver the copyrighted information over a secure connection. In addition, secure transactions can benefit by also matching device IDs to server IDs. MaverickKey IDs provide a level of hardware security required for today's Internet appliances.

## Memory Interfaces

The EP7309 is equipped with a ROM/SRAM/FLASH-style interface that has programmable wait-state timings and includes burst-mode capability, with six chip selects decoding six 256 MB sections of addressable space. For maximum flexibility, each bank can be specified to be 8-, 16-, or 32-bits wide. This allows the use of 8-bit-wide boot ROM options to minimize overall system cost. The on-chip boot ROM can be used in product manufacturing to serially download system code into system FLASH memory. To further minimize system memory requirements and cost, the ARM Thumb instruction set is supported, providing for the use of high-speed 32-bit operations in 16-bit op-codes and yielding industry-leading code density.

Pin Mnemonic	I/O	Pin Description
nCS[5:0]	O	Chip select out
A[27:0]	O	Address output
D[31:0]	I/O	Data I/O
nMOE	O	ROM expansion OP enable
nMWE	O	ROM expansion write enable
HALFWORD	O	Halfword access select output
WORD	O	Word access select output
WRITE	O	Transfer direction

Table 2. Static Memory Interface Pin Assignments

## Digital Audio Capability

The EP7309 uses its powerful 32-bit RISC processing engine to implement audio decompression algorithms in software. The nature of the on-board RISC processor, and the availability of efficient C-compilers and other software development tools, ensures that a wide range of audio decompression algorithms can easily be ported to and run on the EP7309

## Universal Asynchronous Receiver/Transmitters (UARTs)

The EP7309 includes two 16550-type UARTs for RS-232 serial communications, both of which have two 16-byte FIFOs for receiving and transmitting data. The UARTs support bit

rates up to 115.2 kbps. An IrDA SIR protocol encoder/decoder can be optionally switched into the RX/TX signals to/from UART 1 to enable these signals to drive an infrared communication interface directly.

Pin Mnemonic	I/O	Pin Description
TXD[1]	O	UART 1 transmit
RXD[1]	I	UART 1 receive
CTS	I	UART 1 clear to send
DCD	I	UART 1 data carrier detect
DSR	I	UART 1 data set ready
TXD[2]	O	UART 2 transmit
RXD[2]	I	UART 2 receive
LEDDRV	O	Infrared LED drive output
PHDIN	I	Photo diode input

**Table 3. Universal Asynchronous Receiver/Transmitters Pin Assignments**

## Digital Audio Interface (DAI)

The EP7309 integrates an interface to enable a direct connection to many low cost, low power, high quality audio converters. In particular, the DAI can directly interface with the Crystal CS43L41/42/43 low-power audio DACs and the Crystal CS53L32 low-power ADC. Some of these devices feature digital bass and treble boost, digital volume control and compressor-limiter functions.

Pin Mnemonic	I/O	Pin Description
SCLK	O	Serial bit clock
SDOUT	O	Serial data out
SDIN	I	Serial data in
LRCK	O	Sample clock
MCLKIN	I	Master clock input
MCLKOUT	O	Master clock output

**Table 4. DAI Interface Pin Assignments**

*Note:* See [Table 17 on page 10](#) for information on pin multiplexes.

## CODEC Interface

The EP7309 includes an interface to telephony-type CODECs for easy integration into voice-over-IP and other voice

communications systems. The CODEC interface is multiplexed to the same pins as the DAI and SSI2.

Pin Mnemonic	I/O	Pin Description
PCMCLK	O	Serial bit clock
PCMOUT	O	Serial data out
PCMIN	I	Serial data in
PCMSYNC	O	Frame sync

**Table 5. CODEC Interface Pin Assignments**

*Note:* See [Table 17 on page 10](#) for information on pin multiplexes.

## SSI2 Interface

An additional SPI/Microwire1-compatible interface is available for both master and slave mode communications. The SSI2 unit shares the same pins as the DAI and CODEC interfaces through a multiplexer.

- Synchronous clock speeds of up to 512 kHz
- Separate 16 entry TX and RX half-word wide FIFOs
- Half empty/full interrupts for FIFOs
- Separate RX and TX frame sync signals for asymmetric traffic

Pin Mnemonic	I/O	Pin Description
SSICLK	I/O	Serial bit clock
SSITXDA	O	Serial data out
SSIRXDA	I	Serial data in
SSITXFR	I/O	Transmit frame sync
SSIRXFR	I/O	Receive frame sync

**Table 6. SSI2 Interface Pin Assignments**

*Note:* See [Table 17 on page 10](#) for information on pin multiplexes.

## Synchronous Serial Interface

- ADC (SSI) Interface: Master mode only; SPI and Microwire1-compatible (128 kbps operation)
- Selectable serial clock polarity

Pin Mnemonic	I/O	Pin Description
ADCLK	O	SSI1 ADC serial clock
ADCIN	I	SSI1 ADC serial input
ADCOUT	O	SSI1 ADC serial output
nADCCS	O	SSI1 ADC chip select
SMPCLK	O	SSI1 ADC sample clock

Table 7. Serial Interface Pin Assignments

## LCD Controller

A DMA address generator is provided that fetches video display data for the LCD controller from memory. The display frame buffer start address is programmable, allowing the LCD frame buffer to be in SDRAM, internal SRAM or external SRAM.

- Interfaces directly to a single-scan panel monochrome STN LCD
- Interfaces to a single-scan panel color STN LCD with minimal external glue logic
- Panel width size is programmable from 32 to 1024 pixels in 16-pixel increments
- Video frame buffer size programmable up to 128 KB
- Bits per pixel of 1, 2, or 4 bits

Pin Mnemonic	I/O	Pin Description
CL1	O	LCD line clock
CL2	O	LCD pixel clock out
DD[3:0]	O	LCD serial display data bus
FRM	O	LCD frame synchronization pulse
M	O	LCD AC bias drive

Table 8. LCD Interface Pin Assignments

## 64-Keypad Interface

Matrix keyboards and keypads can be easily read by the EP7309. A dedicated 8-bit column driver output generates strobes for each keyboard column signal. The pins of Port A, when configured as inputs, can be selectively OR'ed together to provide a keyboard interrupt that is capable of waking the system from a STANDBY or IDLE state.

- Column outputs can be individually set high with the remaining bits left at high-impedance
- Column outputs can be driven all-low, all-high, or all-high-impedance
- Keyboard interrupt driven by OR'ing together all Port A bits
- Keyboard interrupt can be used to wake up the system
- 8x8 keyboard matrix usable with no external logic, extra keys can be added with minimal glue logic

Pin Mnemonic	I/O	Pin Description
COL[7:0]	O	Keyboard scanner column drive

Table 9. Keypad Interface Pin Assignments

## Interrupt Controller

When unexpected events arise during the execution of a program (i.e., interrupt or memory fault) an exception is usually generated. When these exceptions occur at the same time, a fixed priority system determines the order in which they are handled. The EP7309 interrupt controller has two interrupt types: interrupt request (IRQ) and fast interrupt request (FIQ). The interrupt controller has the ability to control interrupts from 22 different FIQ and IRQ sources.

- Supports 22 interrupts from a variety of sources (such as UARTs, SSI1, and key matrix.)
- Routes interrupt sources to the ARM720T's IRQ or FIQ (Fast IRQ) inputs
- Five dedicated off-chip interrupt lines operate as level sensitive interrupts

Pin Mnemonic	I/O	Pin Description
nEINT[2:1]	I	External interrupt
EINT[3]	I	External interrupt
nEXTFIQ	I	External Fast Interrupt input
nMEDCHG/nBROM (Note)	I	Media change interrupt input

Table 10. Interrupt Controller Pin Assignments

Note: Pins are multiplexed. See Table 18 on page 10 for more information.

## Real-Time Clock

The EP7309 contains a 32-bit Real Time Clock (RTC) that can be written to and read from in the same manner as the timer counters. It also contains a 32-bit output match register which can be programmed to generate an interrupt.

- Driven by an external 32.768 kHz crystal oscillator

Pin Mnemonic	Pin Description
RTCIN	Real-Time Clock Oscillator Input
RTCOUT	Real-Time Clock Oscillator Output
VDDRTC	Real-Time Clock Oscillator Power
VSSRTC	Real-Time Clock Oscillator Ground

**Table 11. Real-Time Clock Pin Assignments**

## PLL and Clocking

- Processor and Peripheral Clocks operate from a single 3.6864 MHz crystal or external 13 MHz clock
- Programmable clock speeds allow the peripheral bus to run at 18 MHz when the processor is set to 18 MHz and at 36 MHz when the processor is set to 36, 49 or 74 MHz

Pin Mnemonic	Pin Description
MOSCIN	Main Oscillator Input
MOSCOUT	Main Oscillator Output
VDDOSC	Main Oscillator Power
VSSOSC	Main Oscillator Ground

**Table 12. PLL and Clocking Pin Assignments**

## DC-to-DC converter interface (PWM)

- Provides two 96 kHz clock outputs with programmable duty ratio (from 1-in-16 to 15-in-16) that can be used to drive a positive or negative DC to DC converter

Pin Mnemonic	I/O	Pin Description
DRIVE[1:0]	I/O	PWM drive output
FB[1:0]	I	PWM feedback input

**Table 13. DC-to-DC Converter Interface Pin Assignments**

## Timers

- Internal (RTC) timer
- Two internal 16-bit programmable hardware count-down timers

## General Purpose Input/Output (GPIO)

- Three 8-bit and one 3-bit GPIO ports
- Supports scanning keyboard matrix

Pin Mnemonic	I/O	Pin Description
PA[7:0]	I/O	GPIO port A
PB[7:0]	I/O	GPIO port B
PD[0]/LEDFLSH (Note)	I/O	GPIO port D
PD[5:1]	I/O	GPIO port D
PD[7:6]/SDQM[1:0] (Note)	I/O	GPIO port D
PE[1:0]/BOOTSEL[1:0] (Note)	I/O	GPIO port E
PE[2]/CLKSEL (Note)	I/O	GPIO port E

**Table 14. General Purpose Input/Output Pin Assignments**

Note: Pins are multiplexed. See [Table 18 on page 10](#) for more information.

## Hardware debug Interface

- Full JTAG boundary scan and Embedded ICE<sup>®</sup> support

Pin Mnemonic	I/O	Pin Description
TCLK	I	JTAG clock
TDI	I	JTAG data input
TDO	O	JTAG data output
nTRST	I	JTAG async reset input
TMS	I	JTAG mode select

**Table 15. Hardware Debug Interface Pin Assignments**

## LED Flasher

A dedicated LED flasher module can be used to generate a low frequency signal on Port D pin 0 for the purpose of blinking an LED without CPU intervention. The LED flasher feature is ideal as a visual annunciator in battery powered applications, such as a voice mail indicator on a portable phone or an appointment reminder on a PDA.

- Software adjustable flash period and duty cycle
- Operates from 32 kHz RTC clock
- Will continue to flash in IDLE and STANDBY states
- 4 mA drive current

Pin Mnemonic	I/O	Pin Description
PD[0]/LEDFLSH (Note)	O	LED flasher driver

**Table 16. LED Flasher Pin Assignments**

Note: Pins are multiplexed. See [Table 18 on page 10](#) for more information.

## Internal Boot ROM

The internal 128 byte Boot ROM facilitates download of saved code to the on-board SRAM/FLASH.

## Packaging

The EP7309 is available in a 208-pin LQFP package, 256-ball PBGA package or a 204-ball TFBGA package.

## Pin Multiplexing

The following table shows the pin multiplexing of the DAI, SSI2 and the CODEC. The selection between SSI2 and the CODEC is controlled by the SERSEL bit in SYSCON2. The choice between the SSI2, CODEC, and the DAI is controlled by the DAISEL bit in SYSCON3 (see the EP7309 User's Manual for more information).

Pin Mnemonic	I/O	DAI	SSI2	CODEC
SSICLK	I/O	SCLK	SSICLK	PCMCLK
SSITXDA	O	SDOUT	SSITXDA	PCMOUT
SSIRXDA	I	SDIN	SSIRXDA	PCMIN

Table 17. DAI/SSI2/CODEC Pin Multiplexing

Pin Mnemonic	I/O	DAI	SSI2	CODEC
SSITXFR	I/O	LRCK	SSITXFR	PCMSYNC
SSIRXFR	I	MCLKIN	SSIRXFR	p/u
BUZ	O	MCLKOUT		

Table 17. DAI/SSI2/CODEC Pin Multiplexing

The following table shows the pins that have been multiplexed in the EP7309.

Signal	Block	Signal	Block
RUN	System Configuration	CLKEN	System Configuration
nMEDCHG	Interrupt Controller	nBROM	Boot ROM select
PD[0]	GPIO	LEDFLSH	LED Flasher
PE[1:0]	GPIO	BOOTSEL[1:0]	System Configuration
PE[2]	GPIO	CLKSEL	System Configuration

Table 18. Pin Multiplexing

## System Design

As shown in system block diagram, simply adding desired memory and peripherals to the highly integrated EP7309

completes a low-power system solution. All necessary interface logic is integrated on-chip.

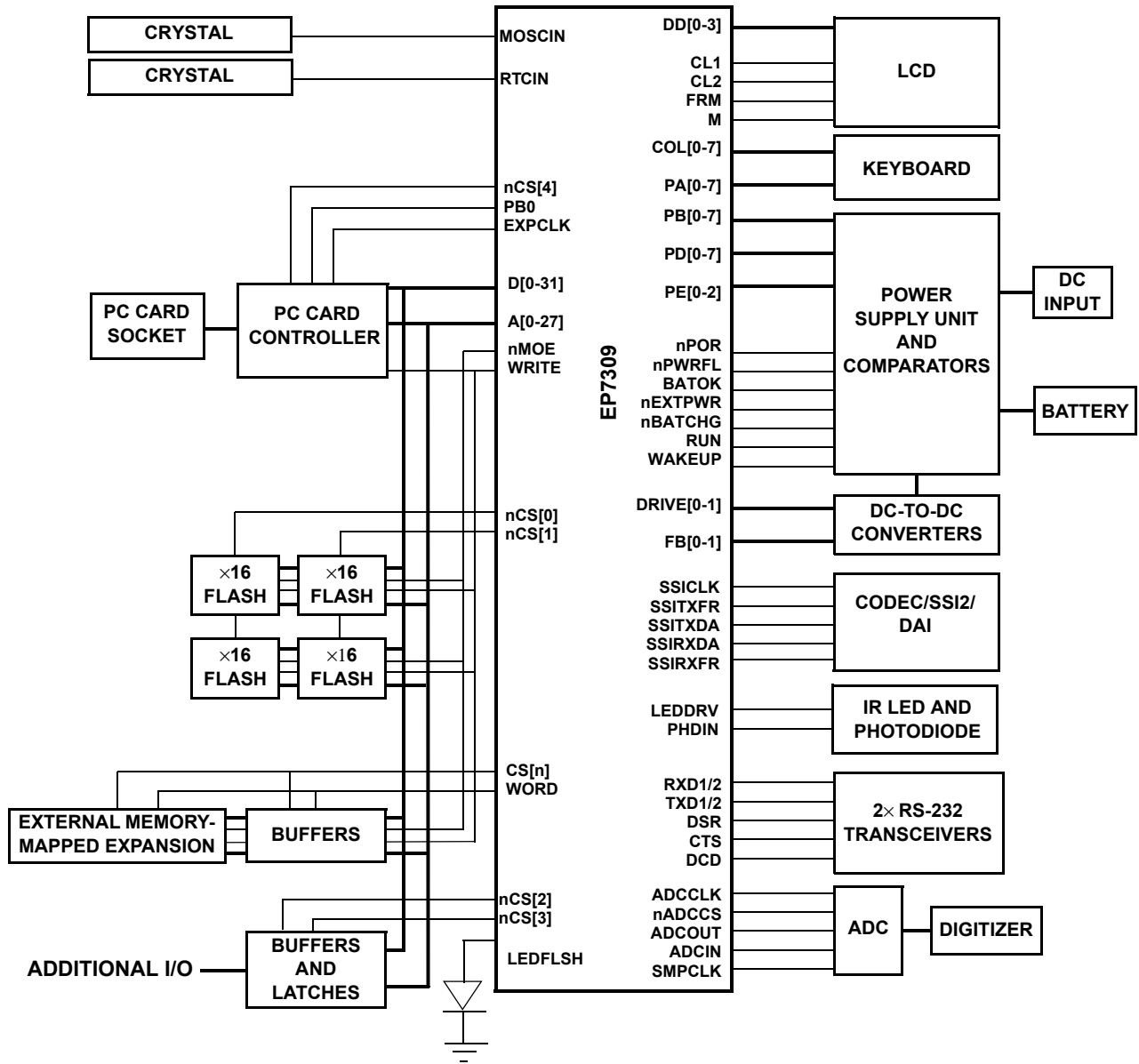

Figure 1. A Maximum EP7309 Based System

*Note:* A system can only use one of the following peripheral interfaces at any given time: SSI2, CODEC or DAI.

## ELECTRICAL SPECIFICATIONS

### Absolute Maximum Ratings

DC Core, PLL, and RTC Supply Voltage	2.9 V
DC I/O Supply Voltage (Pad Ring)	3.6 V
DC Pad Input Current	±10 mA/pin; ±100 mA cumulative
Storage Temperature, No Power	-40°C to +125°C

### Recommended Operating Conditions

DC core, PLL, and RTC Supply Voltage	2.5 V ± 0.2 V
DC I/O Supply Voltage (Pad Ring)	2.3 V - 3.5 V
DC Input / Output Voltage	O-I/O supply voltage
Operating Temperature	Extended -20°C to +70°C; Commercial 0°C to +70°C; Industrial -40°C to +85°C

### DC Characteristics

All characteristics are specified at  $V_{DDCORE} = 2.5$  V,  $V_{DDIO} = 3.3$  V and  $V_{SS} = 0$  V over an operating temperature of 0°C to +70°C for all frequencies of operation. The current consumption figures have test conditions specified per parameter.”

Symbol	Parameter	Min	Typ	Max	Unit	Conditions
VIH	CMOS input high voltage	$0.65 \times V_{DDIO}$	-	$V_{DDIO} + 0.3$	V	$V_{DDIO} = 2.5$ V
VIL	CMOS input low voltage	$V_{SS} - 0.3$	-	$0.25 \times V_{DDIO}$	V	$V_{DDIO} = 2.5$ V
VT+	Schmitt trigger positive going threshold	-	-	2.1	V	
VT-	Schmitt trigger negative going threshold	0.8	-	-	V	
Vhst	Schmitt trigger hysteresis	0.1	-	0.4	V	VIL to VIH
VOH	CMOS output high voltage <sup>a</sup>	$V_{DD} - 0.2$	-	-	V	IOH = 0.1 mA
	Output drive 1 <sup>a</sup>	2.5	-	-	V	IOH = 4 mA
	Output drive 2 <sup>a</sup>	2.5	-	-	V	IOH = 12 mA
VOL	CMOS output low voltage <sup>a</sup>	-	-	0.3	V	IOL = -0.1 mA
	Output drive 1 <sup>a</sup>	-	-	0.5	V	IOL = -4 mA
	Output drive 2 <sup>a</sup>	-	-	0.5	V	IOL = -12 mA
IIN	Input leakage current	-	-	1.0	µA	VIN = $V_{DD}$ or GND
IOZ	Bidirectional 3-state leakage current <sup>b c</sup>	25	-	100	µA	VOU = $V_{DD}$ or GND
CIN	Input capacitance	8	-	10.0	pF	
COUT	Output capacitance	8	-	10.0	pF	

Symbol	Parameter	Min	Typ	Max	Unit	Conditions
CI/O	Transceiver capacitance	8	-	10.0	pF	
IDD <sub>STANDBY</sub> @ 25 C	Standby current consumption <sup>1</sup> Core, Osc, RTC @2.5 V I/O @ 3.3 V	- -	77 41	- -	μA	Only nPOR, nPWRFAIL, nURESET, PE0, PE1, and RTS are driven, while all other float, VIH = V <sub>DD</sub> ± 0.1 V, VIL = GND ± 0.1 V
IDD <sub>STANDBY</sub> @ 70 C	Standby current consumption <sup>1</sup> Core, Osc, RTC @2.5 V I/O @ 3.3 V	- -	- -	570 111	μA	Only nPOR, nPWRFAIL, nURESET, PE0, PE1, and RTS are driven, while all other float, VIH = V <sub>DD</sub> ± 0.1 V, VIL = GND ± 0.1 V
IDD <sub>STANDBY</sub> @ 85 C	Standby current consumption <sup>1</sup> Core, Osc, RTC @2.5 V I/O @ 3.3 V	- -	- -	1693 163	μA	Only nPOR, nPWRFAIL, nURESET, PE0, PE1, and RTS are driven, while all other float, VIH = V <sub>DD</sub> ± 0.1 V, VIL = GND ± 0.1 V
IDD <sub>idle</sub> at 74 MHz	Idle current consumption <sup>1</sup> Core, Osc, RTC @2.5 V I/O @ 3.3 V	- -	6 10	- -	mA	Both oscillators running, CPU static, Cache enabled, LCD disabled, VIH = V <sub>DD</sub> ± 0.1 V, VIL = GND ± 0.1 V
VDD <sub>STANDBY</sub>	Standby supply voltage	2.0	-	-	V	Minimum standby voltage for state retention, internal SRAM cache, and RTC operation only

- Refer to the strength column in the pin assignment tables for all package types.
- Assumes buffer has no pull-up or pull-down resistors.
- The leakage value given assumes that the pin is configured as an input pin but is not currently being driven.

Note: 1) Total power consumption =  $IDD_{CORE} \times 2.5 V + IDD_{IO} \times 3.3 V$   
2) A typical design will provide 3.3 V to the I/O supply (i.e., V<sub>DDIO</sub>), and 2.5 V to the remaining logic. This is to allow the I/O to be compatible with 3.3 V powered external logic (i.e., 3.3 V SDRAMs).  
2) Pull-up current = 50 μA typical at V<sub>DD</sub> = 3.3 V.

## Timings

### Timing Diagram Conventions

This data sheet contains timing diagrams. The following key explains the components used in these diagrams. Any variations are clearly labelled when they occur. Therefore, no additional meaning should be attached unless specifically stated.

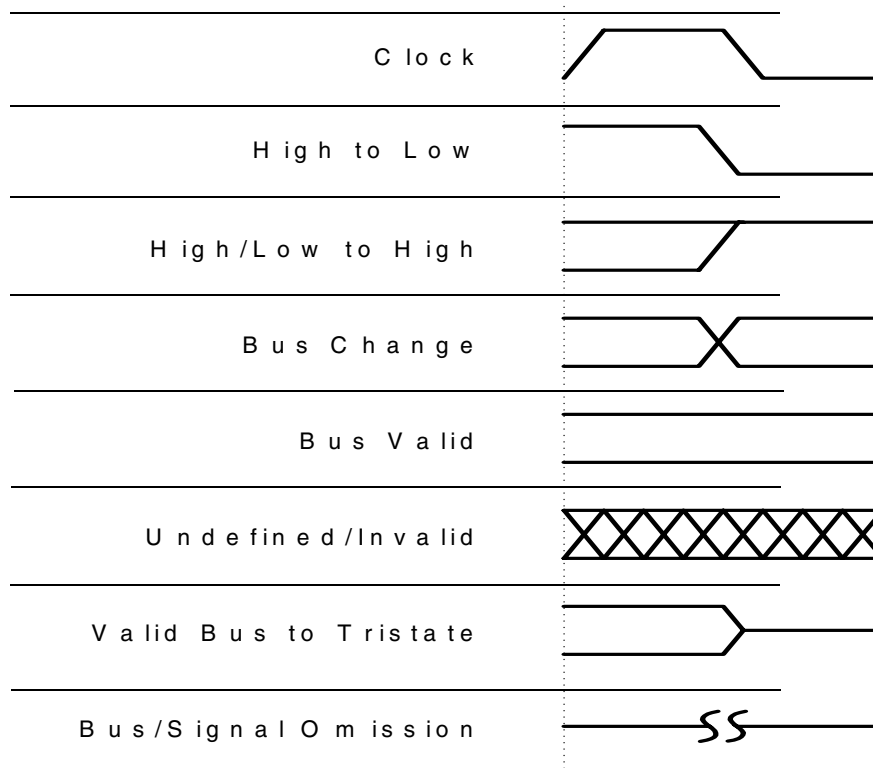

Figure 2. Legend for Timing Diagrams

### Timing Conditions

Unless specified otherwise, the following conditions are true for all timing measurements. All characteristics are specified at  $V_{DDIO} = 3.1 - 3.5 \text{ V}$  and  $V_{SS} = 0 \text{ V}$  over an operating temperature of  $-40^{\circ}\text{C}$  to  $+85^{\circ}\text{C}$ . Pin loadings is  $50 \text{ pF}$ . The timing values are referenced to  $1/2 V_{DD}$ .

## Static Memory

Figure 3 through Figure 6 define the timings associated with all phases of the Static Memory. The following table contains the values for the timings of each of the Static Memory modes.

Parameter	Symbol	Min	Typ	Max	Unit
EXPCLK rising edge to nCS assert delay time	$t_{CSd}$	2	8	20	ns
EXPCLK falling edge to nCS deassert hold time	$t_{CSh}$	2	7	20	ns
EXPCLK rising edge to A assert delay time	$t_{Ad}$	4	9	16	ns
EXPCLK falling edge to A deassert hold time	$t_{Ah}$	3	10	19	ns
EXPCLK rising edge to nMWE assert delay time	$t_{MWd}$	3	6	10	ns
EXPCLK rising edge to nMWE deassert hold time	$t_{MWh}$	3	6	10	ns
EXPCLK falling edge to nMOE assert delay time	$t_{MOEd}$	3	7	10	ns
EXPCLK falling edge to nMOE deassert hold time	$t_{MOEh}$	2	7	10	ns
EXPCLK falling edge to HALFWORD deassert delay time	$t_{HWd}$	2	8	20	ns
EXPCLK falling edge to WORD assert delay time	$t_{WDd}$	2	8	16	ns
EXPCLK rising edge to data valid delay time	$t_{Dv}$	8	13	21	ns
EXPCLK falling edge to data invalid delay time	$t_{Dnv}$	6	15	30	ns
Data setup to EXPCLK falling edge time	$t_{Ds}$	-	-	1	ns
EXPCLK falling edge to data hold time	$t_{Dh}$	-	-	3	ns
EXPCLK rising edge to WRITE assert delay time	$t_{WRd}$	5	11	23	ns
EXPREADY setup to EXPCLK falling edge time	$t_{EXs}$	-	-	0	ns
EXPCLK falling edge to EXPREADY hold time	$t_{EXh}$	-	-	0	ns

### Static Memory Single Read Cycle

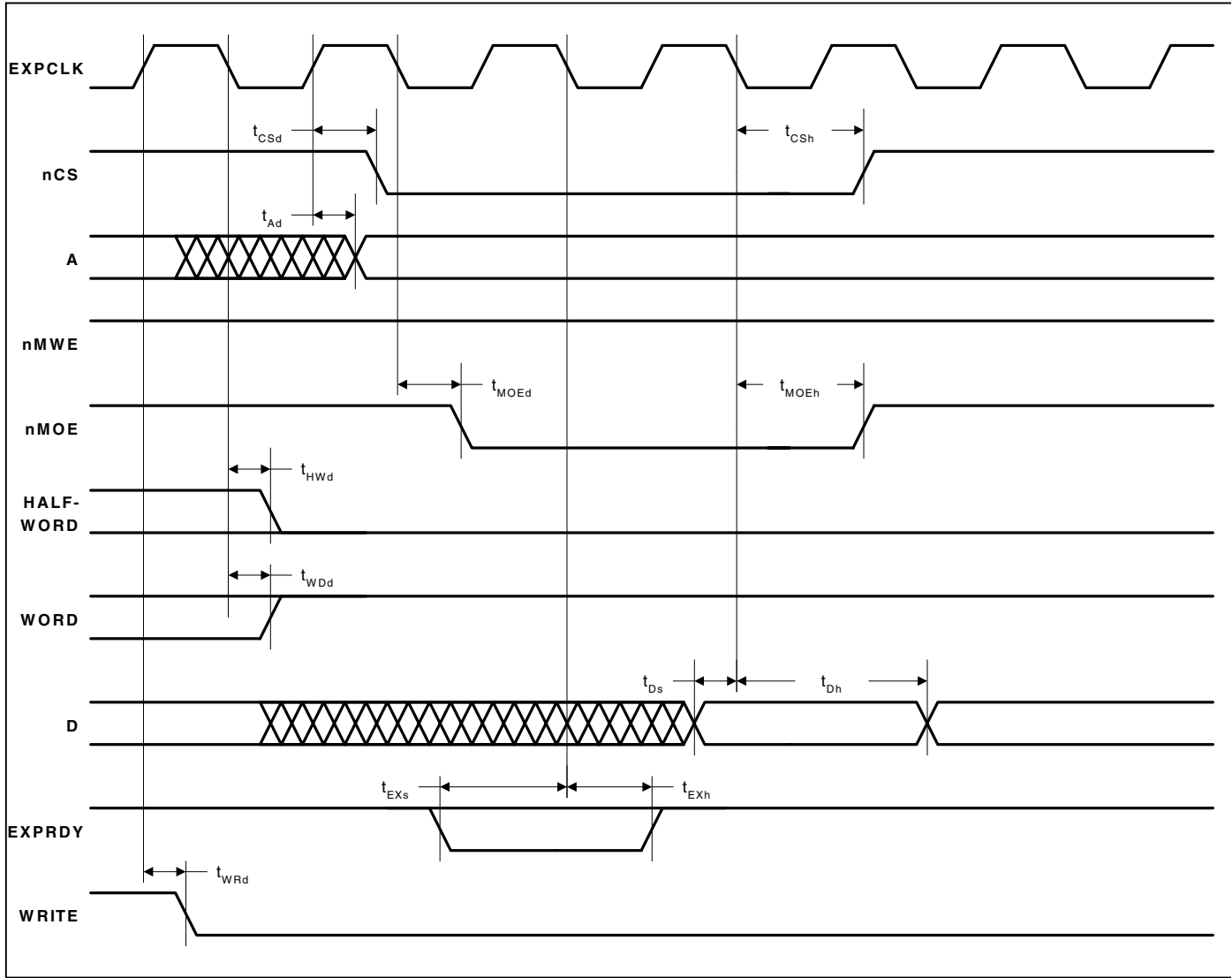
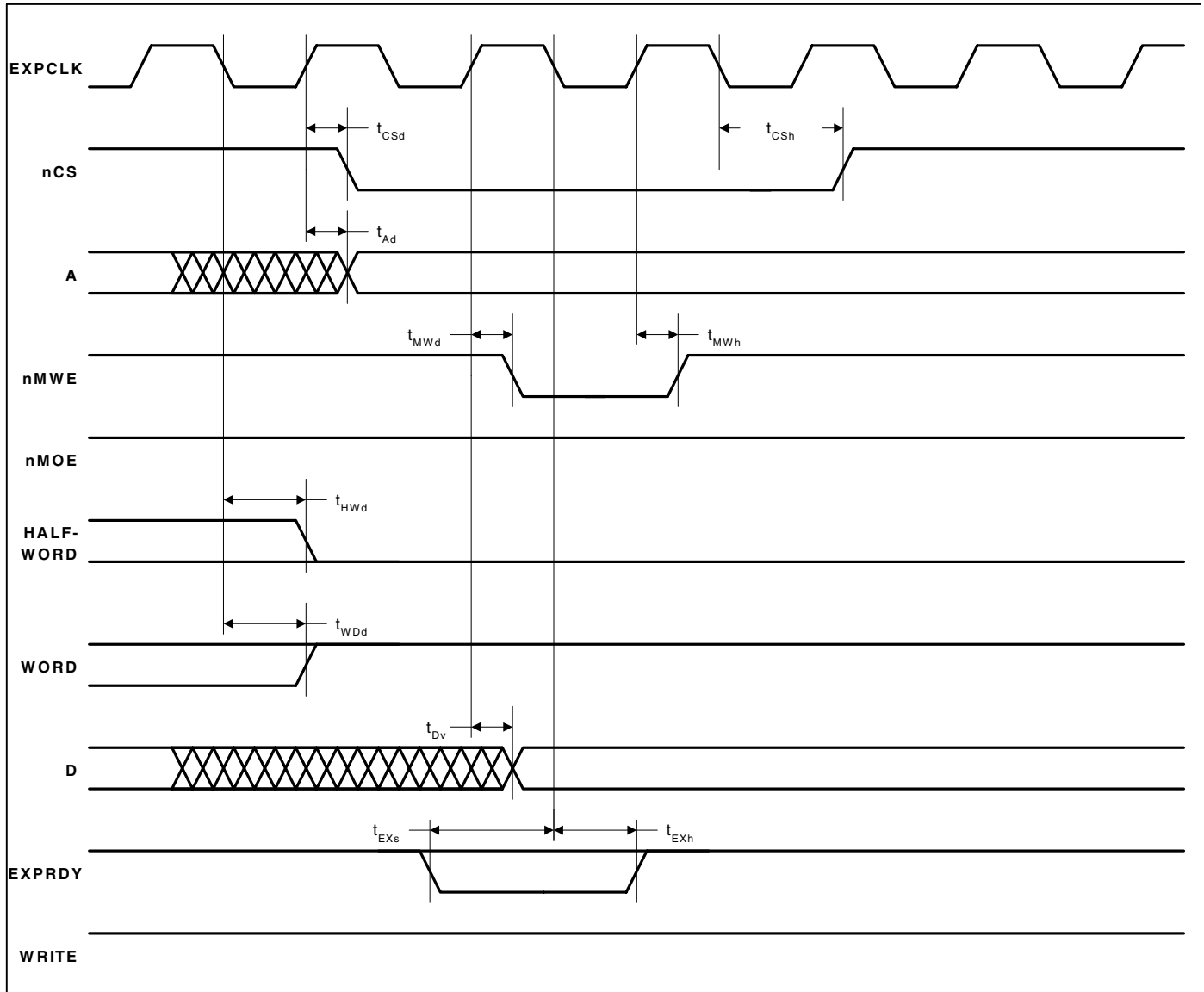

Figure 3. Static Memory Single Read Cycle Timing Measurement

Note: 1. The cycle time can be extended by integer multiples of the clock period (22 ns at 45 MHz, 27 ns at 36 MHz, 54 ns at 18.432 MHz, and 77 ns at 13 MHz), by either driving EXPRDY low and/or by programming a number of wait states. EXPRDY is sampled on the falling edge of EXPCLK before the data transfer. If low at this point, the transfer is delayed by one clock period where EXPRDY is sampled again. EXPCLK need not be referenced when driving EXPRDY, but is shown for clarity.  
2. Address, Halfword, Word, and Write hold state until next cycle.

**Static Memory Single Write Cycle**

**Figure 4. Static Memory Single Write Cycle Timing Measurement**

- Note:
1. The cycle time can be extended by integer multiples of the clock period (22 ns at 45 MHz, 27 ns at 36 MHz, 54 ns at 18.432 MHz, and 77 ns at 13 MHz), by either driving EXPRDY low and/or by programming a number of wait states. EXPRDY is sampled on the falling edge of EXPCLK before the data transfer. If low at this point, the transfer is delayed by one clock period where EXPRDY is sampled again. EXPCLK need not be referenced when driving EXPRDY, but is shown for clarity.
  2. Zero wait states for sequential writes is not permitted for memory devices which use nMWE pin, as this cannot be driven with valid timing under zero wait state conditions.
  3. Address, Data, Halfword, Word, and Write hold state until next cycle.

## Static Memory Burst Read Cycle

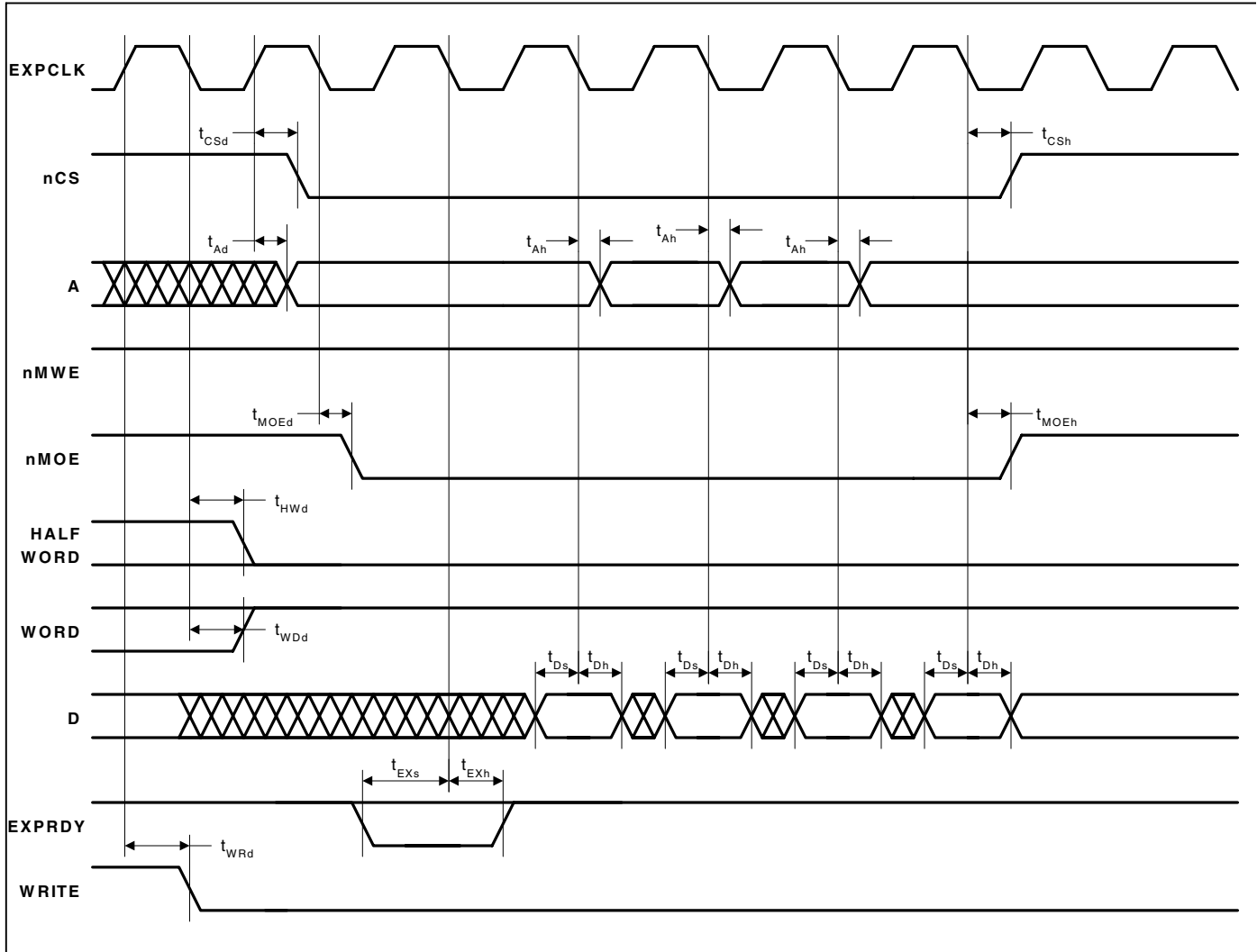
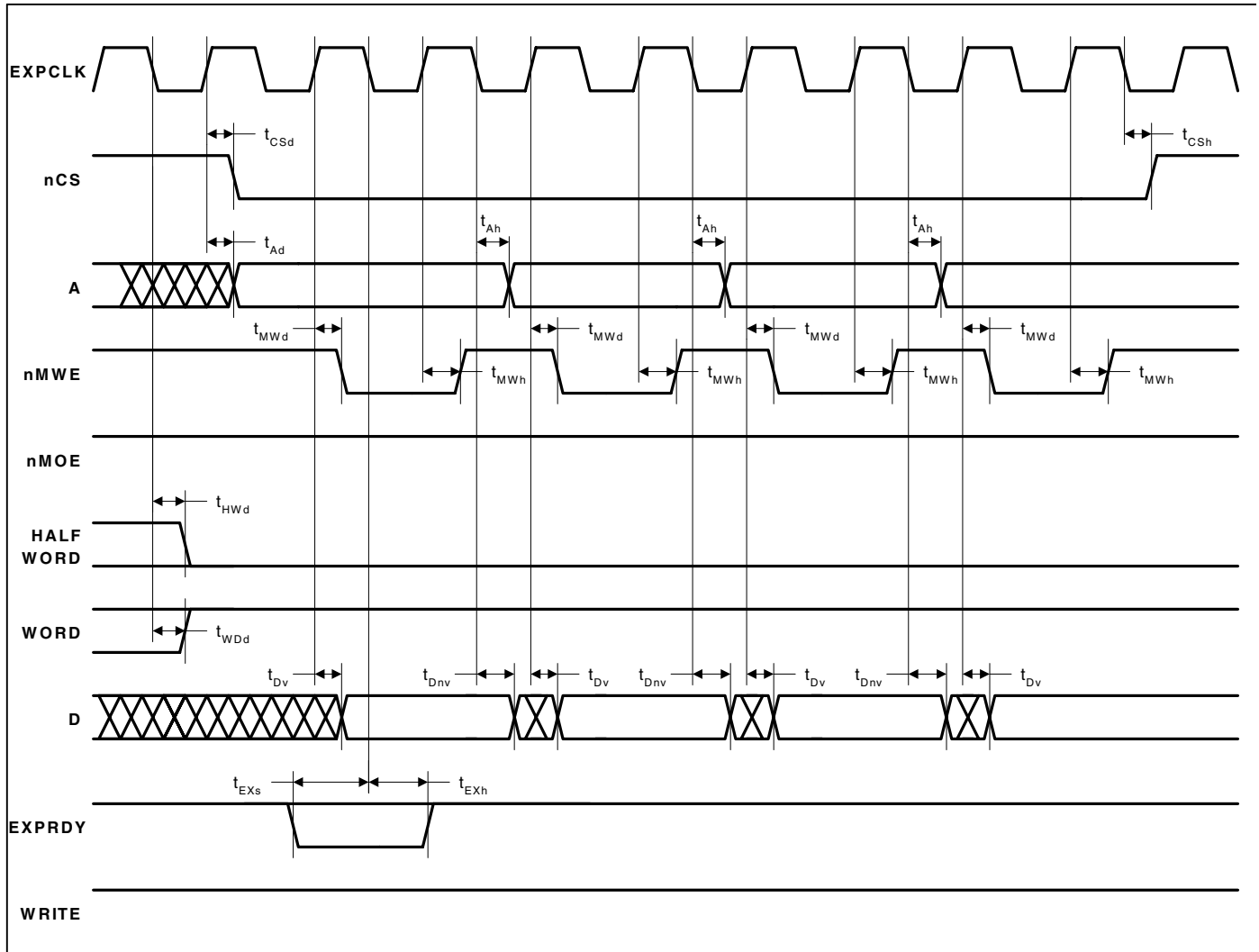

Figure 5. Static Memory Burst Read Cycle Timing Measurement

- Note:
1. Four cycles are shown in the above diagram (minimum wait states, 1-0-0-0). This is the maximum number of consecutive cycles that can be driven. The number of consecutive cycles can be programmed from 2 to 4, inclusively.
  2. The cycle time can be extended by integer multiples of the clock period (22 ns at 45 MHz, 27 ns at 36 MHz, 54 ns at 18.432 MHz, and 77 ns at 13 MHz), by either driving EXPRDY low and/or by programming a number of wait states. EXPRDY is sampled on the falling edge of EXPCLK before the data transfer. If low at this point, the transfer is delayed by one clock period where EXPRDY is sampled again. EXPCLK need not be referenced when driving EXPRDY, but is shown for clarity.
  3. Consecutive reads with sequential access enabled are identical except that the sequential access wait state field is used to determine the number of wait states, and no idle cycles are inserted between successive non-sequential ROM/expansion cycles. This improves performance so the SQAEN bit should always be set where possible.
  4. Address, Halfword, Word, and Write hold state until next cycle.

**Static Memory Burst Write Cycle**

**Figure 6. Static Memory Burst Write Cycle Timing Measurement**

- Note:*
1. Four cycles are shown in the above diagram (minimum wait states, 1-1-1-1). This is the maximum number of consecutive cycles that can be driven. The number of consecutive cycles can be programmed from 2 to 4, inclusively.
  2. The cycle time can be extended by integer multiples of the clock period (22 ns at 45 MHz, 27 ns at 36 MHz, 54 ns at 18.432 MHz, and 77 ns at 13 MHz), by either driving EXPRDY low and/or by programming a number of wait states. EXPRDY is sampled on the falling edge of EXPCLK before the data transfer. If low at this point, the transfer is delayed by one clock period where EXPRDY is sampled again. EXPCLK need not be referenced when driving EXPRDY, but is shown for clarity.
  3. Zero wait states for sequential writes is not permitted for memory devices which use nMWE pin, as this cannot be driven with valid timing under zero wait state conditions.
  4. Address, Data, Halfword, Word, and Write hold state until next cycle.

## SSI1 Interface

Parameter	Symbol	Min	Max	Unit
ADCCLK falling edge to nADCCSS deassert delay time	$t_{Cd}$	9	10	ms
ADCIN data setup to ADCCLK rising edge time	$t_{INs}$	-	15	ns
ADCIN data hold from ADCCLK rising edge time	$t_{INh}$	-	14	ns
ADCCLK falling edge to data valid delay time	$t_{Ovd}$	-7	13	ns
ADCCLK falling edge to data invalid delay time	$t_{Oid}$	-2	3	ns

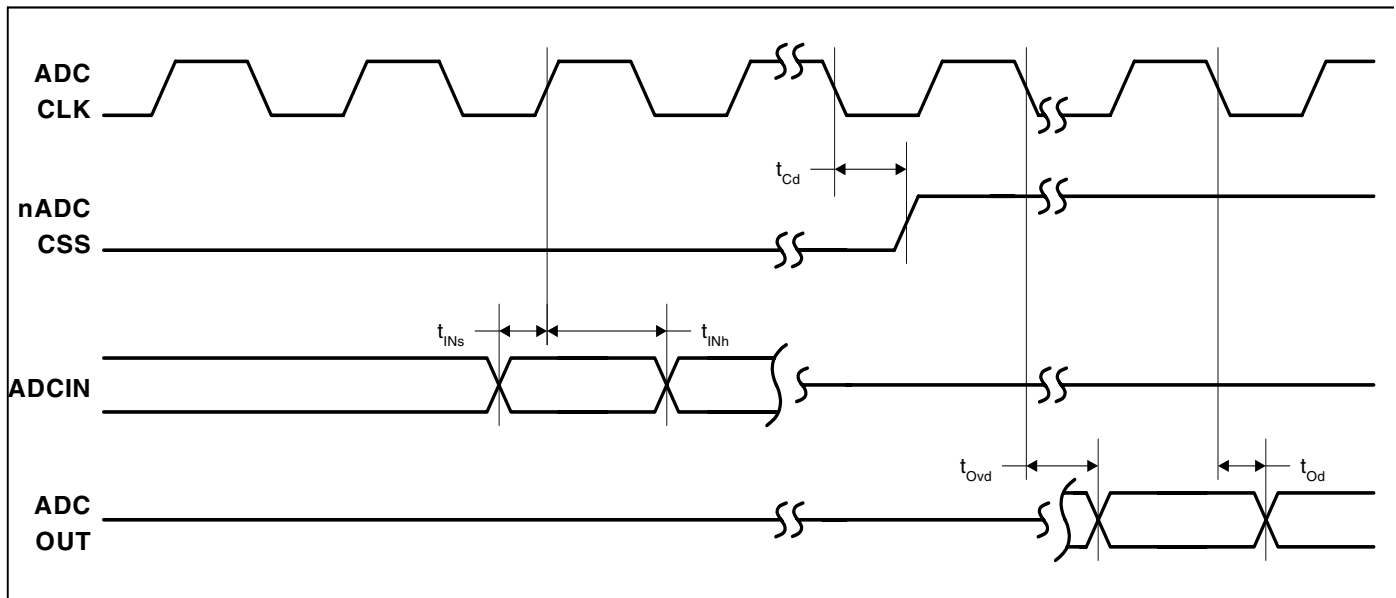

Figure 7. SSI1 Interface Timing Measurement

## SSI2 Interface

Parameter	Symbol	Min	Max	Unit
SSICLK period (slave mode)	$t_{clk\_per}$	185	2050	ns
SSICLK high time	$t_{clk\_high}$	925	1025	ns
SSICLK low time	$t_{clk\_low}$	925	1025	ns
SSICLK rise/fall time	$t_{clkrf}$	3	18	ns
SSICLK rising edge to RX and/or TX frame sync high time	$t_{FRd}$	-	3	ns
SSICLK rising edge to RX and/or TX frame sync low time	$t_{FRa}$	-	8	ns
SSIRXFR and/or SSITXFR period	$t_{FR\_per}$	960	990	ns
SSIRXDA setup to SSICLK falling edge time	$t_{RXs}$	3	7	ns
SSIRXDA hold from SSICLK falling edge time	$t_{RXh}$	3	7	ns
SSICLK rising edge to SSITXDA data valid delay time	$t_{TXd}$	-	2	ns
SSITXDA valid time	$t_{TXv}$	960	990	ns

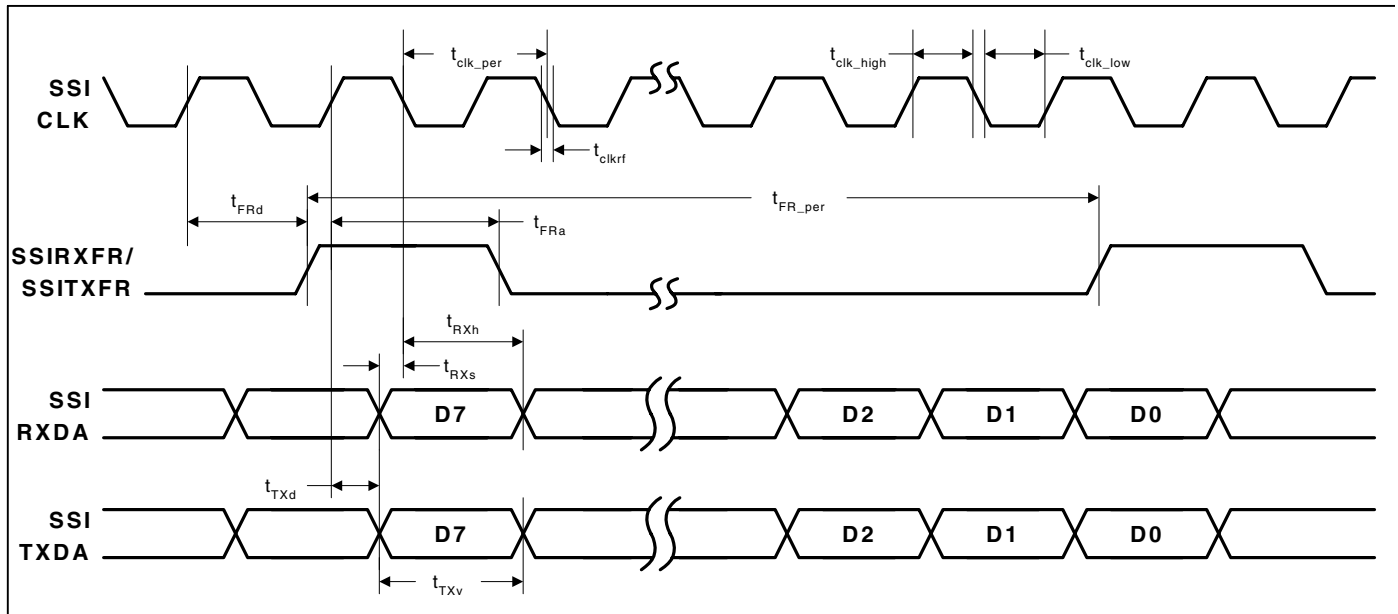

Figure 8. SSI2 Interface Timing Measurement

## LCD Interface

Parameter	Symbol	Min	Max	Unit
CL[2] falling to CL[1] rising delay time	$t_{CL1d}$	- 10	25	ns
CL[1] falling to CL[2] rising delay time	$t_{CL2d}$	80	3,475	ns
CL[1] falling to FRM transition time	$t_{FRMd}$	300	10,425	ns
CL[1] falling to M transition time	$t_{Md}$	- 10	20	ns
CL[2] rising to DD (display data) transition time	$t_{DDd}$	- 10	20	ns

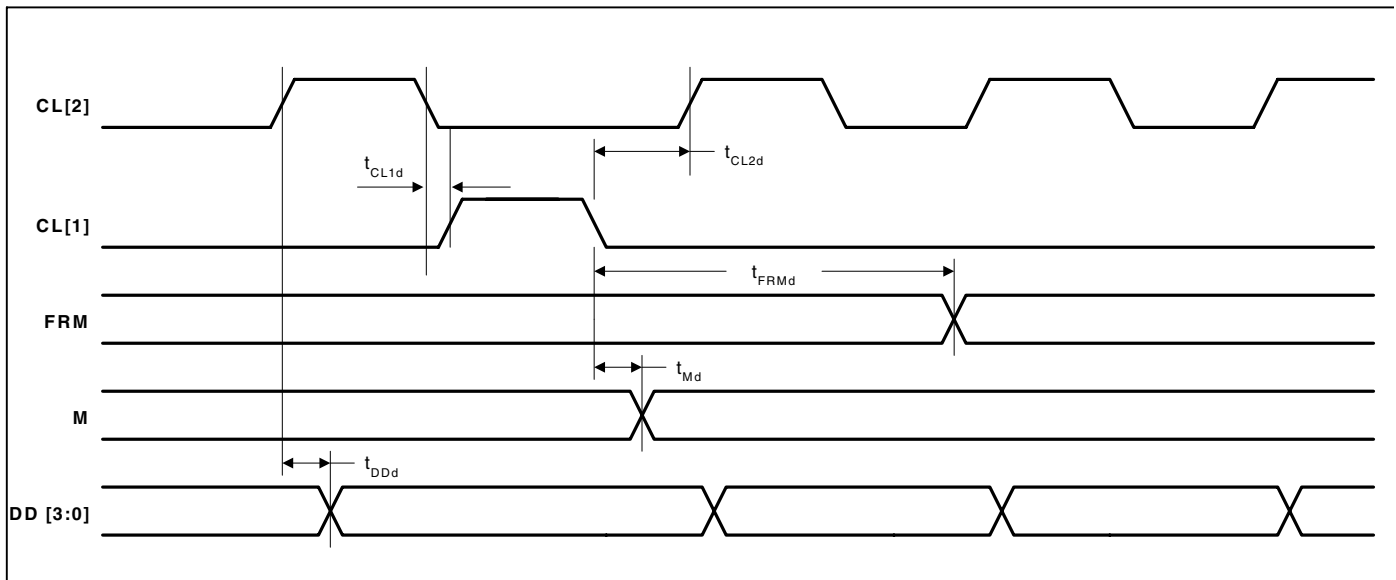
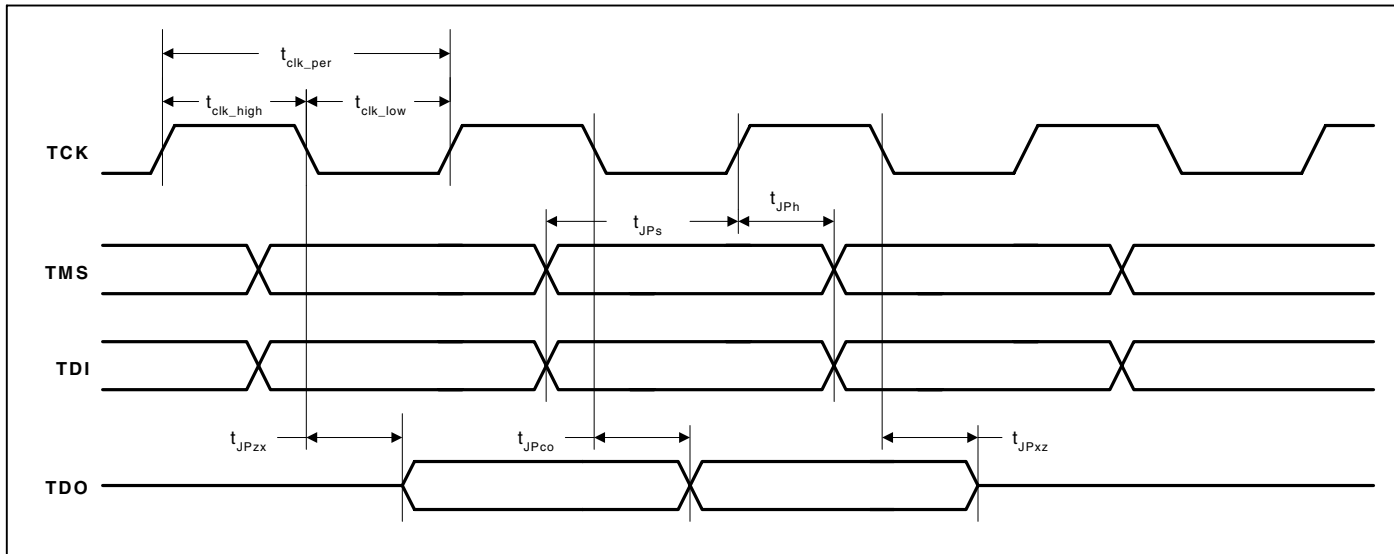

Figure 9. LCD Controller Timing Measurement

## JTAG Interface

Parameter	Symbol	Min	Max	Units
TCK clock period	$t_{clk\_per}$	2	-	ns
TCK clock high time	$t_{clk\_high}$	1	-	ns
TCK clock low time	$t_{clk\_low}$	1	-	ns
JTAG port setup time	$t_{JP_s}$	-	0	ns
JTAG port hold time	$t_{JP_h}$	-	3	ns
JTAG port clock to output	$t_{JP_{co}}$	-	10	ns
JTAG port high impedance to valid output	$t_{JP_{zx}}$	-	12	ns
JTAG port valid output to high impedance	$t_{JP_{xz}}$	-	19	ns



**Figure 10. JTAG Timing Measurement**

## Packages

### 208-Pin LQFP Package Characteristics

#### 208-Pin LQFP Package Specifications

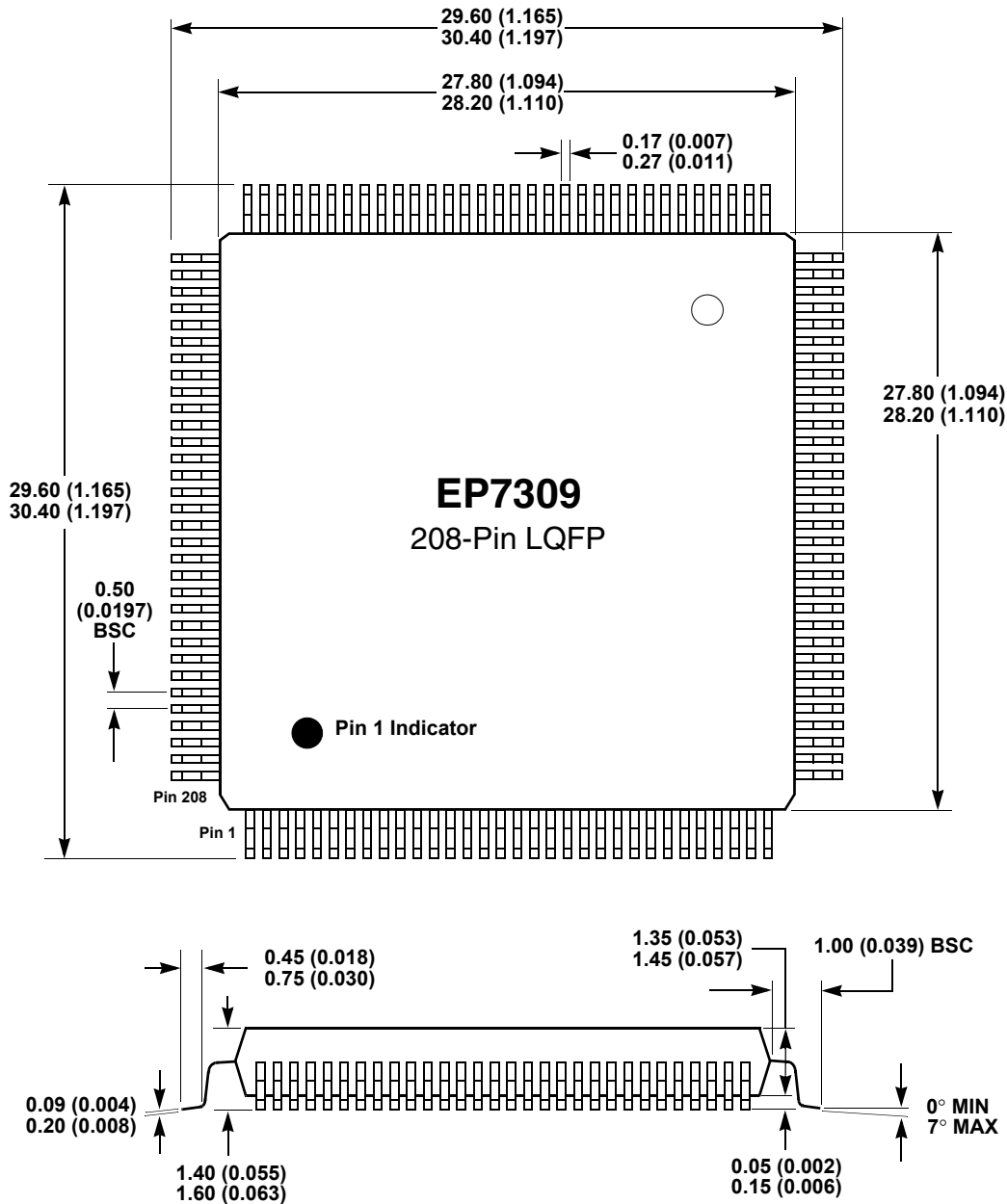
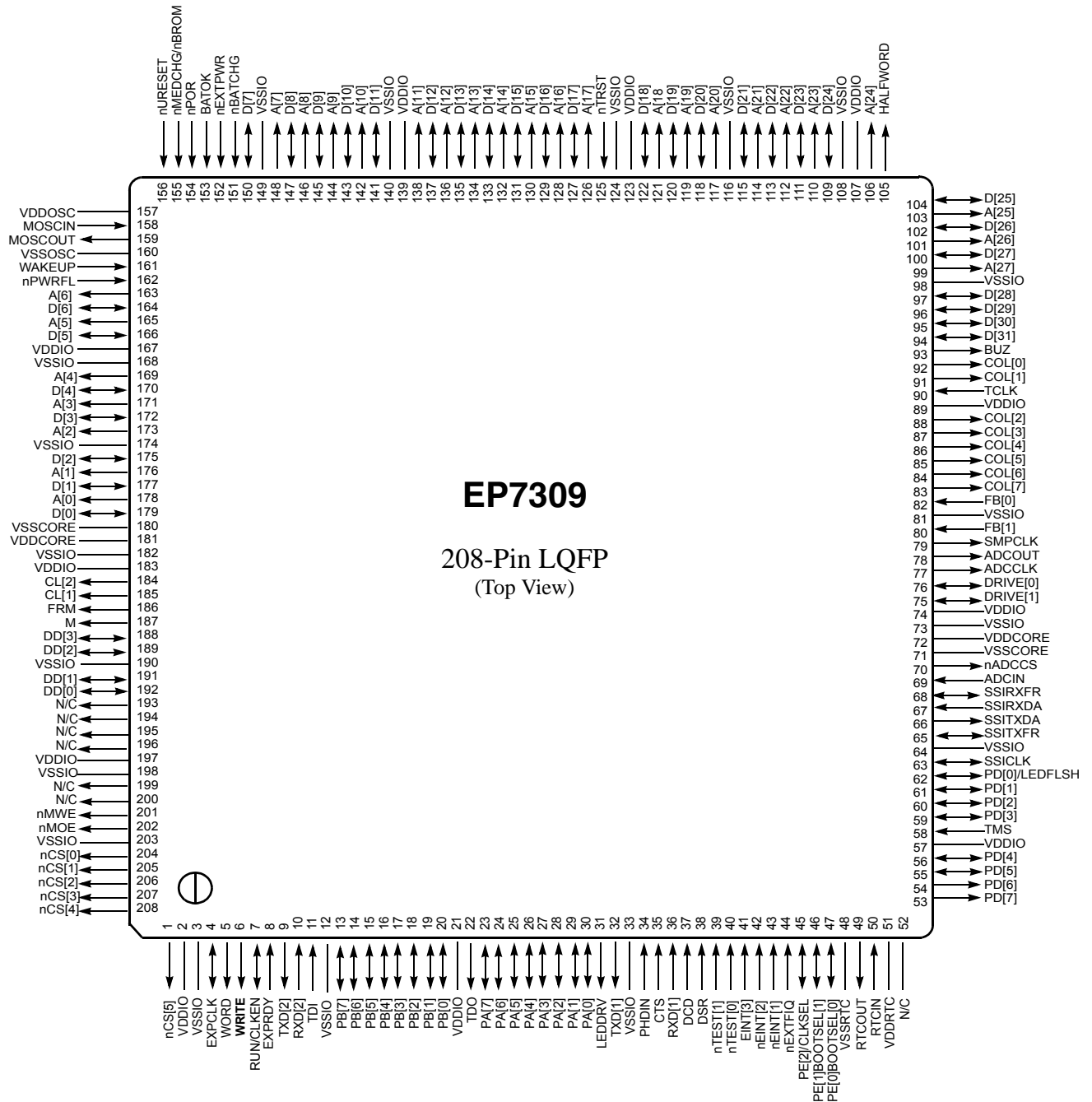

Figure 11. 208-Pin LQFP Package Outline Drawing

- Note:
- 1) Dimensions are in millimeters (inches), and controlling dimension is millimeter.
  - 2) Drawing above does not reflect exact package pin count.
  - 3) Before beginning any new design with this device, please contact Cirrus Logic for the latest package information.
  - 4) For pin locations, please see [Figure 12](#). For pin descriptions see the EP7309 User's Manual.

**208-Pin LQFP Pin Diagram**

**Figure 12. 208-Pin LQFP (Low Profile Quad Flat Pack) Pin Diagram**

- Note:
1. N/C should not be grounded but left as no connects.
  2. Pin differences between the EP7212 and the EP7309 are bolded.

## 208-Pin LQFP Numeric Pin Listing

Table 19. 208-Pin LQFP Numeric Pin Listing

Pin No.	Signal	Type	Strength	Reset State
1	nCS[5]	O	1	High
2	VDDIO	Pad Pwr		
3	VSSIO	Pad Gnd		
4	EXPCLK	I/O	1	
5	WORD	Out	1	Low
6	WRITE	Out	1	Low
7	RUN/CLKEN	O	1	Low
8	EXPRDY	I	1	
9	TXD[2]	O	1	High
10	RXD[2]	I		
11	TDI	I	with p/u*	
12	VSSIO	Pad Gnd		
13	PB[7]	I/O	1	Input
14	PB[6]	I/O	1	Input
15	PB[5]	I/O	1	Input
16	PB[4]	I/O	1	Input
17	PB[3]	I/O	1	Input
18	PB[2]	I/O	1	Input
19	PB[1]/PRDY2	I/O	1	Input
20	PB[0]/PRDY1	I/O	1	Input
21	VDDIO	Pad Pwr		
22	TDO	O	1	Three state
23	PA[7]	I/O	1	Input
24	PA[6]	I/O	1	Input
25	PA[5]	I/O	1	Input
26	PA[4]	I/O	1	Input
27	PA[3]	I/O	1	Input
28	PA[2]	I/O	1	Input
29	PA[1]	I/O	1	Input
30	PA[0]	I/O	1	Input
31	LEDDRV	O	1	Low
32	TXD[1]	O	1	High
33	VSSIO	Pad Gnd	1	High
34	PHDIN	I		
35	CTS	I		
36	RXD[1]	I		

Table 19. 208-Pin LQFP Numeric Pin Listing (Continued)

Pin No.	Signal	Type	Strength	Reset State
37	DCD	I		
38	DSR	I		
39	nTEST[1]	I	With p/u*	
40	nTEST[0]	I	With p/u*	
41	EINT[3]	I		
42	nEINT[2]	I		
43	nEINT[1]	I		
44	nEXTFIQ	I		
45	PE[2]/CLKSEL	I/O	1	Input
46	PE[1]/ BOOTSEL[1]	I/O	1	Input
47	PE[0]/ BOOTSEL[0]	I/O	1	Input
48	VSSRTC	RTC Gnd		
49	RTCCOUT	O		
50	RTCCIN	I		
51	VDDRTC	RTC power		
52	N/C			
53	PD[7]	I/O	1	Low
54	PD[6]	I/O	1	Low
55	PD[5]	I/O	1	Low
56	PD[4]	I/O	1	Low
57	VDDIO	Pad Pwr		
58	TMS	I	with p/u*	
59	PD[3]	I/O	1	Low
60	PD[2]	I/O	1	Low
61	PD[1]	I/O	1	Low
62	PD[0]/LEDFLSH	I/O	1	Low
63	SSICLK	I/O	1	Input
64	VSSIO	Pad Gnd		
65	SSITXFR	I/O	1	Low
66	SSITXDA	O	1	Low
67	SSIRXDA	I		
68	SSIRXFR	I/O		Input
69	ADCIN	I		
70	nADCCS	O	1	High
71	VSSCORE	Core Gnd		
72	VDDCORE	Core Pwr		

**Table 19. 208-Pin LQFP Numeric Pin Listing (Continued)**

Pin No.	Signal	Type	Strength	Reset State
73	VSSIO	Pad Gnd		
74	VDDIO	Pad Pwr		
75	DRIVE[1]	I/O	2	High / Low
76	DRIVE[0]	I/O	2	High / Low
77	ADCCLK	O	1	Low
78	ADCOUT	O	1	Low
79	SMPCLK	O	1	Low
80	FB[1]	I		
81	VSSIO	Pad Gnd		
82	FB[0]	I		
83	COL[7]	O	1	High
84	COL[6]	O	1	High
85	COL[5]	O	1	High
86	COL[4]	O	1	High
87	COL[3]	O	1	High
88	COL[2]	O	1	High
89	VDDIO	Pad Pwr		
90	TCLK	I		
91	COL[1]	O	1	High
92	COL[0]	O	1	High
93	BUZ	O	1	Low
94	D[31]	I/O	1	Low
95	D[30]	I/O	1	Low
96	D[29]	I/O	1	Low
97	D[28]	I/O	1	Low
98	VSSIO	Pad Gnd		
99	A[27]	O	2	Low
100	D[27]	I/O	1	Low
101	A[26]	O	2	Low
102	D[26]	I/O	1	Low
103	A[25]	O	2	Low
104	D[25]	I/O	1	Low
105	HALFWORD	O	1	Low
106	A[24]	O	1	Low
107	VDDIO	Pad Pwr		—
108	VSSIO	Pad Gnd		—
109	D[24]	I/O	1	Low

**Table 19. 208-Pin LQFP Numeric Pin Listing (Continued)**

Pin No.	Signal	Type	Strength	Reset State
110	A[23]	O	1	Low
111	D[23]	I/O	1	Low
112	A[22]	O	1	Low
113	D[22]	I/O	1	Low
114	A[21]	O	1	Low
115	D[21]	I/O	1	Low
116	VSSIO	Pad Gnd		
117	A[20]	O	1	Low
118	D[20]	I/O	1	Low
119	A[19]	O	1	Low
120	D[19]	I/O	1	Low
121	A[18]	O	1	Low
122	D[18]	I/O	1	Low
123	VDDIO	Pad Pwr		
124	VSSIO	Pad Gnd		
125	nTRST	I		
126	A[17]	O	1	Low
127	D[17]	I/O	1	Low
128	A[16]	O	1	Low
129	D[16]	I/O	1	Low
130	A[15]	O	1	Low
131	D[15]	I/O	1	Low
132	A[14]	O	1	Low
133	D[14]	I/O	1	Low
134	A[13]	O	1	Low
135	D[13]	I/O	1	Low
136	A[12]	O	1	Low
137	D[12]	I/O	1	Low
138	A[11]	O	1	Low
139	VDDIO	Pad Pwr		
140	VSSIO	Pad Gnd		
141	D[11]	I/O	1	Low
142	A[10]	O	1	Low
143	D[10]	I/O	1	Low
144	A[9]	O	1	Low
145	D[9]	I/O	1	Low
146	A[8]	O	1	Low
147	D[8]	I/O	1	Low

Table 19. 208-Pin LQFP Numeric Pin Listing (Continued)

Pin No.	Signal	Type	Strength	Reset State
148	A[7]	O	1	Low
149	VSSIO	Pad Gnd		
150	D[7]	I/O	1	Low
151	nBATCHG	I		
152	nEXTPWR	I		
153	BATOK	I		
154	nPOR	I	Schmitt	
155	nMEDCHG/ nBROM	I		
156	nURESET	I	Schmitt	
157	VDDOSC	Osc Pwr		
158	MOSCIN	Osc		
159	MOSCOU	Osc		
160	VSSOSC	Osc Gnd		
161	WAKEUP	I	Schmitt	
162	nPWRFL	I		
163	A[6]	O	1	Low
164	D[6]	I/O	1	Low
165	A[5]	Out	1	Low
166	D[5]	I/O	1	Low
167	VDDIO	Pad Pwr		
168	VSSIO	Pad Gnd		
169	A[4]	O	1	Low
170	D[4]	I/O	1	Low
171	A[3]	O	2	Low
172	D[3]	I/O	1	Low
173	A[2]	O	2	Low
174	VSSIO	Pad Gnd		
175	D[2]	I/O	1	Low
176	A[1]	O	2	Low
177	D[1]	I/O	1	Low
178	A[0]	O	2	Low
179	D[0]	I/O	1	Low
180	VSS CORE	Core Gnd		
181	VDD CORE	Core Pwr		
182	VSSIO	Pad Gnd		
183	VDDIO	Pad Pwr		
184	CL[2]	O	1	Low
185	CL[1]	O	1	Low

Table 19. 208-Pin LQFP Numeric Pin Listing (Continued)

Pin No.	Signal	Type	Strength	Reset State
186	FRM	O	1	Low
187	M	O	1	Low
188	DD[3]	I/O	1	Low
189	DD[2]	I/O	1	Low
190	VSSIO	Pad Gnd		
191	DD[1]	I/O	1	Low
192	DD[0]	I/O	1	Low
193	N/C	O	1	High
194	N/C	O	1	High
195	N/C	I/O	2	Low
196	N/C	I/O	2	Low
197	VDDIO	Pad Pwr		
198	VSSIO	Pad Gnd		
199	N/C	I/O	2	Low
200	N/C	I/O	2	Low
201	nMWE	O	1	High
202	nMOE	O	1	High
203	VSSIO	Pad Gnd		
204	nCS[0]	O	1	High
205	nCS[1]	O	1	High
206	nCS[2]	O	1	High
207	nCS[3]	O	1	High
208	nCS[4]	O	1	High

\*With p/u' means with internal pull-up on the pin.

## 204-Ball TFBGA Package Characteristics

### 204-Ball TFBGA Package Specifications

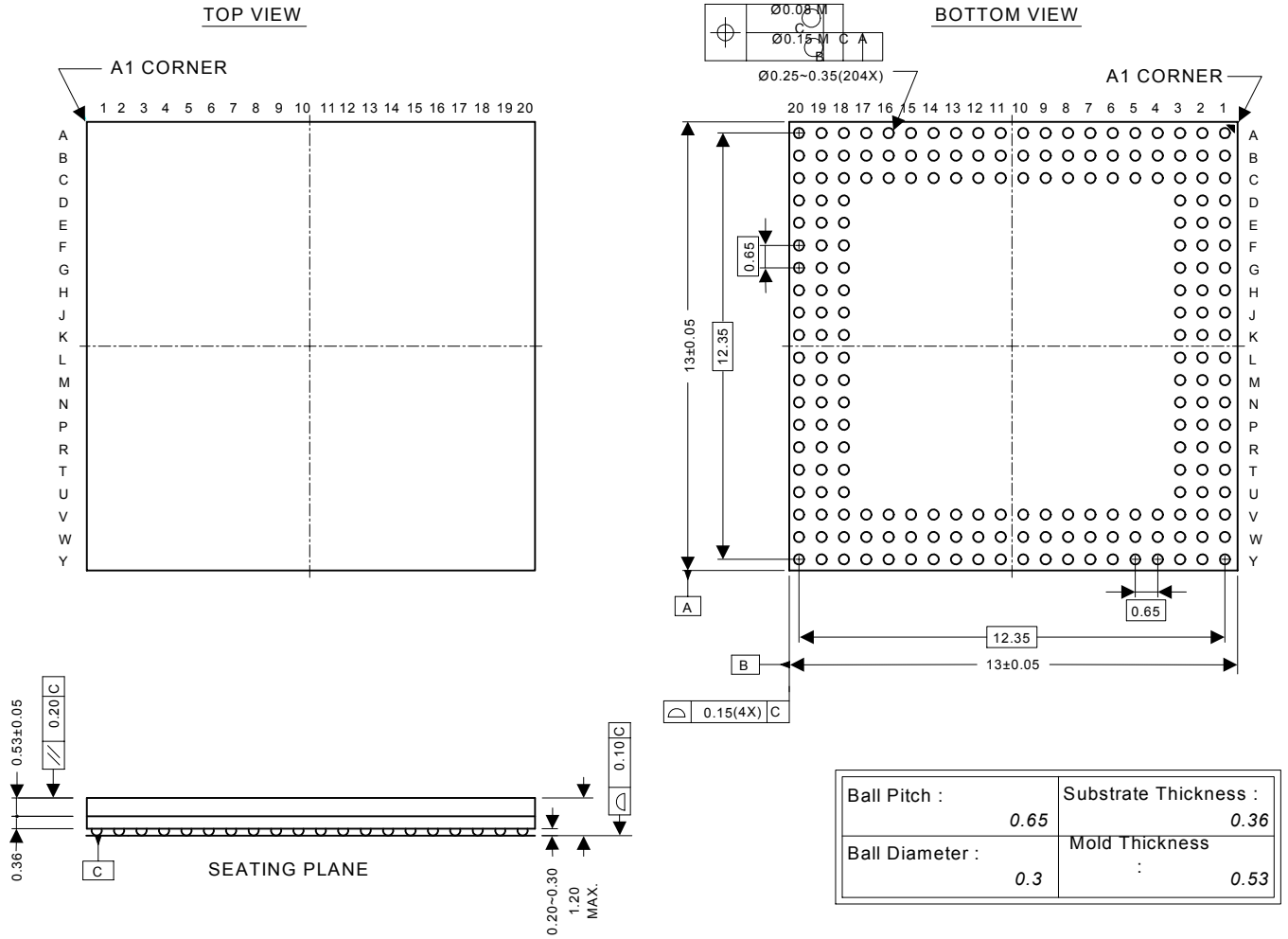

**Figure 13. 204-Ball TFBGA Package**

**204-Ball TFBGA Pinout (Top View)**

	1	2	3	4	5	6	7	8	9	10	11	12	13	14	15	16	17	18	19	20	
A	VDDR	EXPCLK	nCS3	nCS1	nMWE	N/C	N/C	DD2	FRM	CL1	GNDD	D1	A2	D4	A5	nPWRFL	MOSCOUT	GNDR	GNDR	GNDR	A
B	WORD	VDDR	nCS5	nCS2	nMOE	N/C	N/C	DD1	M	CL2	D0	A1	D3	A4	D6	WAKEUP	MOSCIN	GNDR	GNDR	nURESET	B
C	RUN/ CLKEN	EXPRDY	VDDR	nCS4	nCS0	N/C	N/C	DD0	DD3	VDDD	A0	D2	A3	D5	A6	GNDO	VDDO	GNDR	BATOK	nPOR	C
D	PB7	RXD2	VDDR															GNDR	nBATCHG	A7	D
E	PB4	TXD2	WRITE															nMEDCHG /nBROM	nEXTPWR	D9	E
F	PB3	PB6	TDI															D7	A8	D10	F
G	PB1	PB2	PB5															D8	A9	D11	G
H	PA7	TDO	PB0															A10	D12	A12	H
J	PA4	PA5	PA6															A11	D13	A13	J
K	PA1	PA2	VDDR															D14	A14	D15	K
L	TXD1	LEDDR	PA3															VDDR	D16	A16	L
M	RXD1	CTS	PA0															A15	A17	nTRST	M
N	DSR	nTEST1	PHDIN															D17	D19	A18	N
P	EINT3	nEINT2	DCD															D18	A20	D20	P
R	nEXTFIQ	PE2/ CLKSEL	nTEST0															A19	D22	A21	R
T	PE1/ BOOT SEL1	PE0/ BOOT SEL0	nEINT1															D21	D23	A22	T
U	GNDC	RTCOUT	RTCIN															HALF WORD	D24	A23	U
V	VDDC	GNDR	GNDR	PD7	PD4	PD2	SSICLK	SSIRXDA	nADCCS	VDDR	ADCCLK	COL7	COL4	TCLK	BUZ	D29	A26	VDDR	VDDR	A24	V
W	GNDR	GNDR	GNDR	PD6	TMS	PD1	SSITXFR	SSIRXFR	GNDD1	DRIVE1	ADCOUT	FB0	COL5	COL2	COL0	D30	A27	D26	VDDR	D25	W
Y	GNDR	GNDR	GNDR	PD5	PD3	PD0/ LED FLSH	SSITXDA	ADCIN	VDD1	DRIVE0	SMPCLK	FB1	COL6	COL3	COL1	D31	D28	D27	A25	VDDR	Y

## 204-Ball TFBGA Ball Listing

The list is ordered by ball location.

**Table 20. 204-Ball TFBGA Ball Listing**

Ball Location	Name	Strength †	Reset State	Type	Description
A1	VDDIO			Pad power	Digital I/O power, 3.3 V
A2	EXPCLK	1		I	Expansion clock input
A3	nCS[3]	1	High	O	Chip select 3
A4	nCS[1]	1	High	O	Chip select 1
A5	nMWE/nSDWE	1	High	O	ROM, expansion write enable/ SDRAM write enable control signal
A6	N/C				
A7	N/C				
A8	DD[2]	1	Low	O	LCD serial display data
A9	FRM	1	Low	O	LCD frame synchronization pulse
A10	CL[1]	1	Low	O	LCD line clock
A11	VSSCORE			Core ground	Core ground
A12	D[1]	1	Low	I/O	Data I/O
A13	A[2]	2	Low	O	System byte address
A14	D[4]	1	Low	I/O	Data I/O
A15	A[5]	1	Low	O	System byte address
A16	nPWRFL			I	Power fail sense input
A17	MOSCOU			O	Main oscillator out
A18	VSSIO			Pad ground	I/O ground
A19	VSSIO			Pad ground	I/O ground
A20	VSSIO			Pad ground	I/O ground
B1	WORD	1	Low	O	Word access select output
B2	VDDIO			Pad power	Digital I/O power, 3.3 V
B3	nCS[5]	1	Low	O	Chip select 5
B4	nCS[2]	1	High	O	Chip select 2
B5	nMOE/nSDCAS	1	High	O	ROM, expansion OP enable/SDRAM CAS control signal
B6	N/C				
B7	N/C				
B8	DD[1]	1	Low	O	LCD serial display data
B9	M	1	Low	O	LCD AC bias drive
B10	CL[2]	1	Low	O	LCD pixel clock out
B11	D[0]	1	Low	I/O	Data I/O
B12	A[1]	2	Low	O	System byte address
B13	D[3]	2	Low	I/O	Data I/O
B14	A[4]	1	Low	O	System byte address

Table 20. 204-Ball TFBGA Ball Listing (Continued)

Ball Location	Name	Strength †	Reset State	Type	Description
B15	D[6]	1	Low	I/O	Data I/O
B16	WAKEUP	Schmitt		I	System wake up input
B17	MOSCIN			I	Main oscillator input
B18	VSSIO			Pad ground	I/O ground
B19	VSSIO			Pad ground	I/O ground
B20	nURESET	Schmitt		I	User reset input
C1	RUN/CLKEN	1	Low	0	Run output / clock enable output
C2	EXPRDY	1		I	Expansion port ready input
C3	VDDIO			Pad power	Digital I/O power, 3.3 V
C4	nCS[4]	1	High	O	Chip select 4
C5	nCS[0]	1	High	O	Chip select 0
C6	N/C				
C7	N/C				
C8	DD[0]	1	Low	O	LCD serial display data
C9	DD[3]	1	Low	O	LCD serial display data
C10	VDDCORE			Core power	Digital core power, 2.5 V
C11	A[0]	2	Low	O	System byte address
C12	D[2]	1	Low	I/O	Data I/O
C13	A[3]	2	Low	O	System byte address
C14	D[5]	1	Low	I/O	Data I/O
C15	A[6]	1	Low	O	System byte address
C16	VSSOSC			Oscillator ground	PLL ground
C17	VDDOSC			Oscillator power	Oscillator power in, 2.5V
C18	VSSIO			Pad ground	I/O ground
C19	BATOK			I	Battery ok input

**Table 20. 204-Ball TFBGA Ball Listing (Continued)**

Ball Location	Name	Strength †	Reset State	Type	Description
C20	nPOR	Schmitt		I	Power-on reset input
D1	PB[7]	1	Input †	I	GPIO port B
D2	RXD[2]			I	UART 2 receive data input
D3	VDDIO			Pad power	Digital I/O power, 3.3V
D18	VSSIO			Pad ground	I/O ground
D19	nBATCHG			I	Battery changed sense input
D20	A[7]	1	Low	O	System byte address
E1	PB[4]	1	Input †	I	GPIO port B
E2	TXD[2]	1	High	O	UART 2 transmit data output
E3	WRITE/nSDRAS	1	Low	O	Transfer direction / SDRAM RAS signal output
E18	nMEDCHG/nBROM			I	Media change interrupt input / internal ROM boot enable
E19	nEXTPWR			I	External power supply sense input
E20	D[9]	1	Low	I/O	Data I/O
F1	PB[3]	1	Input †	I/O	GPIO port B
F2	PB[6]	1	Input †	I/O	GPIO port B
F3	TDI	with p/u*		I	JTAG data input
F18	D[7]	1	Low	I/O	Data I/O
F19	A[8]	1	Low	O	System byte address
F20	D[10]	1	Low	I/O	Data I/O
G1	PB[1]	1	Input †	I/O	
G2	PB[2]	1	Input †	I/O	GPIO port B
G3	PB[5]	1	Input †	I/O	GPIO port B
G18	D[8]	1	Input †	I/O	Data I/O
G19	A[9]	1	Low	O	System byte address
G20	D[11]	1	Low	I/O	Data I/O
H1	PA[7]	1	Input †	I/O	GPIO port A
H[2]	TDO	1	Input †	O	JTAG data out
H[3]	PB[0]	1	Input †	I/O	GPIO port B
H[18]	A[10]	1	Low	O	System byte address
H19	D[12]	1	Low	I/O	Data I/O
H20	A[12]	1	Low	O	System byte address
J1	PA[4]	1	Input †	I/O	GPIO port A

Table 20. 204-Ball TFBGA Ball Listing (Continued)

Ball Location	Name	Strength †	Reset State	Type	Description
J2	PA[5]	1	Input †	I/O	GPIO port A
J3	PA[6]	1	Input †	I/O	GPIO port A
J18	A[11]	1	Low	O	System byte address
J19	D[13]	1	Low	I/O	Data I/O
J20	A[13]/DRA[14]	1	Low	O	System byte address / SDRAM address
K1	PA[1]	1	Input †	I/O	GPIO port A
K2	PA[2]	1	Input †	I/O	GPIO port A
K3	VDDIO			Pad power	Digital I/O power, 3.3V
K18	D[14]	1	Low	I/O	Data I/O
K19	A[14]/DRA[13]	1	Low	O	System byte address / SDRAM address
K20	D[15]	1	Low	I/O	Data I/O
L1	TXD[1]	1	High	O	UART 1 transmit data out
L2	LEDDRV	1	Low	O	IR LED drive
L3	PA[3]	1	Input †	I/O	GPIO port A
L18	VDDIO			Pad power	Digital I/O power, 3.3V
L19	D[16]	1	Low	I/O	Data I/O
L20	A[16]/DRA[11]	1	Low	O	System byte address / SDRAM address
M1	RXD[1]			I	UART 1 receive data input
M2	CTS			I	UART 1 clear to send input
M3	PA[0]	1	Input †	I/O	GPIO port A
M18	A[15]/DRA[12]	1	Low	O	System byte address / SDRAM address
M19	A[17]/DRA[10]	1	Low	O	System byte address / SDRAM address
M20	nTRST			I	JTAG async reset input
N1	DSR			I	UART 1 data set ready input
N2	nTEST[1]	With p/u*		I	Test mode select input
N3	PHDIN			I	Photodiode input
N18	D[17]	1	Low	I/O	Data I/O
N19	D[19]	1	Low	I/O	Data I/O
N20	A[18]/DRA[9]	1	Low	O	System byte address / SDRAM address
P1	EINT[3]			I	External interrupt
P2	nEINT[2]			I	External interrupt input
P3	DCD			I	UART 1 data carrier detect
P18	D[18]	1	Low	I/O	Data I/O
P19	A[20]/DRA[7]	1	Low	O	System byte address / SDRAM address

**Table 20. 204-Ball TFBGA Ball Listing (Continued)**

Ball Location	Name	Strength †	Reset State	Type	Description
P20	D[20]	1	Low	I/O	Data I/O
R1	nEXTFIQ			I	External fast interrupt input
R2	PE[2]/CLKSEL	1	Input †	I/O	GPIO port E / clock input mode select
R3	nTEST[0]	With p/u*		I	Test mode select input
R18	A[19]/DRA[8]	1	Low	O	System byte address / SDRAM address
R19	D[22]	1	Low	I/O	Data I/O
R20	A[21]/DRA[6]	1	Low	O	System byte address / SDRAM address
T1	PE[1]/BOOTSEL[1]	1	Input †	I/O	GPIO port E / boot mode select
T2	PE[0]/BOOTSEL[0]	1	Input †	I/O	GPIO port E / boot mode select
T3	nEINT[1]			I	External interrupt input
T18	D[21]	1	Low	I/O	Data I/O
T19	D[23]	1	Low	I/O	Data I/O
T20	A[22]/DRA[5]	1	Low	O	System byte address / SDRAM address
U1	VSSRTC			RTC ground	Real time clock ground
U2	RTCOUT			O	Real time clock oscillator output
U3	RTCIN			I/O	Real time clock oscillator input
U18	HALFWORD	1	Low	O	Halfword access select output
U19	D[24]	1	Low	I/O	Data I/O
U20	A[23]/DRA[4]	1	Low	O	System byte address / SDRAM address
V1	VDDRTC			RTC power	Real time clock power, 2.5V
V2	VSSIO			Pad ground	I/O ground
V3	VSSIO			Pad ground	I/O ground
V4	PD[7]/SDQM[1]	1	Low	I/O	GPIO port D / SDRAM byte lane mask
V5	PD[4]	1	Low	I/O	GPIO port D
V6	PD[2]	1	Low	I/O	GPIO port D
V7	SSICLK	1	Input †	I/O	DAI/CODEC/SSI2 serial clock
V8	SSIRXDA			I/O	DAI/CODEC/SSI2 serial data input
V9	nADCCS	1	High	O	SSI1 ADC chip select
V10	VDDIO			Pad power	Digital I/O power, 3.3V
V11	ADCCLK	1	Low	O	SSI1 ADC serial clock
V12	COL[7]	1	High	O	Keyboard scanner column drive
V13	COL[4]	1	High	O	Keyboard scanner column drive
V14	TCLK			I	JTAG clock
V15	BUZ	1	Low	O	Buzzer drive output
V16	D[29]	1	Low	I/O	Data I/O

Table 20. 204-Ball TFBGA Ball Listing (Continued)

Ball Location	Name	Strength <sup>†</sup>	Reset State	Type	Description
V17	A[26]/DRA[1]	2	Low	O	System byte address / SDRAM address
V18	VDDIO			Pad power	Digital I/O power, 3.3 V
V19	VDDIO			Pad power	Digital I/O power, 3.3 V
V20	A[24]/DRA[3]		Low	O	System byte address / SDRAM address
W1	VSSIO			Pad ground	I/O ground
W2	VSSIO			Pad ground	I/O ground
W3	VSSIO			Pad ground	I/O ground
W4	PD[6]/SDQM[0]	1	Low	I/O	GPIO port D / SDRAM byte lane mask
W5	TMS	with p/u*		I	JTAG mode select
W6	PD[1]	1	Low	I/O	GPIO port D
W7	SSITXFR	1	Low	I/O	DAI/CODEC/SSI2 frame sync
W8	SSIRXFR	1	Input <sup>‡</sup>	I/O	DAI/CODEC/SSI2 frame sync
W9	VSSCORE			Core Ground	Core Ground
W10	DRIVE[1]	2	High / Low	I/O	PWM drive output
W11	ADCOUT	1	Low	O	SSI1 ADC serial data output
W12	FB[0]			I	PWM feedback input
W13	COL[5]	1	High	O	Keyboard scanner column drive
W14	COL[2]	1	High	O	Keyboard scanner column drive
W15	COL[0]	1	High	O	Keyboard scanner column drive
W16	D[30]	1	Low	I/O	Data I/O
W17	A[27]/DRA[0]	2	Low	O	System byte address / SDRAM address
W18	D[26]	1	Low	I/O	Data I/O
W19	VDDIO			Pad power	Digital I/O power, 3.3V
W20	D[25]	1	Low	I/O	Data I/O
Y1	VSSIO			Pad ground	I/O ground
Y2	VSSIO			Pad ground	I/O ground
Y3	VSSIO			Pad ground	I/O ground
Y4	PD[5]	1	Low	I/O	GPIO port D
Y5	PD[3]	1	Low	I/O	GPIO port D
Y6	PD[0]/LEDFLSH	1	Low	I/O	GPIO port D / LED blinker output
Y7	SSITXDA	1	Low	O	DAI/CODEC/SSI2 serial data output
Y8	ADCIN			I	SSI1 ADC serial input
Y9	VDDCORE			Core power	Digital core power, 2.5V
Y10	DRIVE[0]	2	Input <sup>‡</sup>	I/O	PWM drive output

**Table 20. 204-Ball TFBGA Ball Listing (Continued)**

Ball Location	Name	Strength †	Reset State	Type	Description
Y11	SMPCLK	1	Low	O	SSI1 ADC sample clock
Y12	FB[1]			I	PWM feedback input
Y13	COL[6]	1	High	O	Keyboard scanner column drive
Y14	COL[3]	1	High	O	Keyboard scanner column drive
Y15	COL[1]	1	High	O	Keyboard scanner column drive
Y16	D[31]	1	Low	I/O	Data I/O
Y17	D[28]	1	Low	I/O	Data I/O
Y18	D[27]	1	Low	I/O	Data I/O
Y19	A[25]/DRA[2]	2	Low	O	System byte address / SDRAM address
Y20	VDDIO			Pad power	Digital I/O power, 3.3V

\* "With p/u" means with internal pull-up of 100 KOhms on the pin.

† Strength 1 = 4 ma

Strength 2 = 12 ma

‡ Input. Port A,B,D,E GPIOs default to input at nPOR and URESET conditions.

## 256-Ball PBGA Package Characteristics

### 256-Ball PBGA Package Specifications

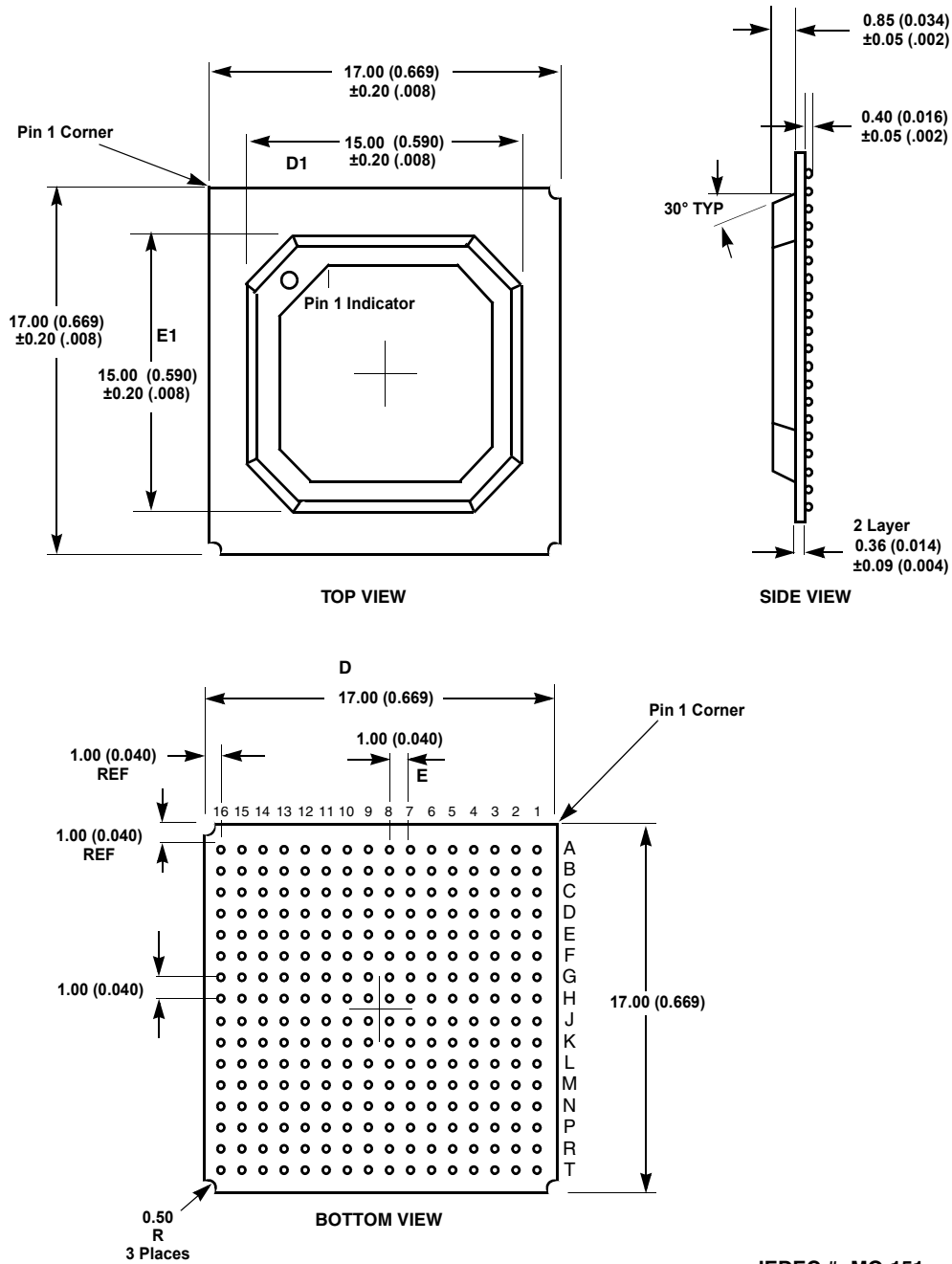

JEDEC #: MO-151  
Ball Diameter: 0.50 mm ± 0.10 mm  
17 ¥ 17 ¥ 1.61 mm body

Figure 14. 256-Ball PBGA Package

- Note:
- 1) For pin locations see [Table 21](#).
  - 2) Dimensions are in millimeters (inches), and controlling dimension is millimeter
  - 3) Before beginning any new EP7309 design, contact Cirrus Logic for the latest package information.

**256-Ball PBGA Pinout (Top View)**

	1	2	3	4	5	6	7	8	9	10	11	12	13	14	15	16	
A	VDDIO	nCS[4]	nCS[1]	N/C	N/C	DD[1]	M	VDDIO	D[0]	D[2]	A[3]	VDDIO	A[6]	MOSCOU	VDDOSC	VSSIO	A
B	nCS[5]	VDDIO	nCS[3]	nMOE	VDDIO	N/C	DD[2]	CL[1]	VDDCORE	D[1]	A[2]	A[4]	A[5]	WAKEUP	VDDIO	nURESET	B
C	VDDIO	EXPCLK	VSSIO	VDDIO	VSSIO	VSSIO	VSSIO	VDDIO	VSSIO	VSSIO	VSSIO	VDDIO	VSSIO	VSSIO	nPOR	nEXTPWR	C
D	WRITE	EXPRDY	VSSIO	VDDIO	nCS[2]	nMWE	N/C	CL[2]	VSSRTC	D[4]	nPWRFL	MOSCIN	VDDIO	VSSIO	D[7]	D[8]	D
E	RXD[2]	PB[7]	TDI	WORD	VSSIO	nCS[0]	N/C	FRM	A[0]	D[5]	VSSOSC	VSSIO	nMEDCHG/ nBROM	VDDIO	D[9]	D[10]	E
F	PB[5]	PB[3]	VSSIO	TXD[2]	RUN/ CLKEN	VSSIO	N/C	DD[3]	A[1]	D[6]	VSSRTC	BATOK	nBATCHG	VSSIO	D[11]	VDDIO	F
G	PB[1]	VDDIO	TDO	PB[4]	PB[6]	VSSRTC	VSSRTC	DD[0]	D[3]	VSSRTC	A[7]	A[8]	A[9]	VSSIO	D[12]	D[13]	G
H	PA[7]	PA[5]	VSSIO	PA[4]	PA[6]	PB[0]	PB[2]	VSSRTC	VSSRTC	A[10]	A[11]	A[12]	A[13]	VSSIO	D[14]	D[15]	H
J	PA[3]	PA[1]	VSSIO	PA[2]	PA[0]	TXD[1]	CTS	VSSRTC	VSSRTC	A[17]	A[16]	A[15]	A[14]	nTRST	D[16]	D[17]	J
K	LEDDRV	PHDIN	VSSIO	DCD	nTEST[1]	EINT[3]	VSSRTC	ADCIN	COL[4]	TCLK	D[20]	D[19]	D[18]	VSSIO	VDDIO	VDDIO	K
L	RXD[1]	DSR	VDDIO	nEINT[1]	PE[2]/ CLKSEL	VSSRTC	PD[0]/ LEDFLSH	VSSRTC	COL[6]	D[31]	VSSRTC	A[22]	A[21]	VSSIO	A[18]	A[19]	L
M	nTEST[0]	nEINT[2]	VDDIO	PE[0]/ BOOTSEL[0]	TMS	VDDIO	SSITXFR	DRIVE[1]	FB[0]	COL[0]	D[27]	VSSIO	A[23]	VDDIO	A[20]	D[21]	M
N	nEXTFIQ	PE[1]/ BOOTSEL[1]	VSSIO	VDDIO	PD[5]	PD[2]	SSIRXDA	ADCCLK	SMPCLK	COL[2]	D[29]	D[26]	HALFWORD	VSSIO	D[22]	D[23]	N
P	VSSRTC	RTCOU	VSSIO	VSSIO	VDDIO	VSSIO	VSSIO	VDDIO	VSSIO	VDDIO	VSSIO	VSSIO	VDDIO	VSSIO	D[24]	VDDIO	P
R	RTCIN	VDDIO	PD[4]	PD[1]	SSITXDA	nADCCS	VDDIO	ADCOUT	COL[7]	COL[3]	COL[1]	D[30]	A[27]	A[25]	VDDIO	A[24]	R
T	VDDRTC	PD[7]	PD[6]	PD[3]	SSICLK	SSIRXFR	VDDCORE	DRIVE[0]	FB[1]	COL[5]	VDDIO	BUZ	D[28]	A[26]	D[25]	VSSIO	T

**256-Ball PBGA Ball Listing**

The list is ordered by ball location.

**Table 21. 256-Ball PBGA Ball Listing**

Ball Location	Name	Type	Description
A1	VDDIO	Pad power	Digital I/O power, 3.3V
A2	nCS[4]	O	Chip select out
A3	nCS[1]	O	Chip select out
A4	N/C	O	
A5	N/C	O	
A6	DD[1]	O	LCD serial display data
A7	M	O	LCD AC bias drive
A8	VDDIO	Pad power	Digital I/O power, 3.3V
A9	D[0]	I/O	Data I/O
A10	D[2]	I/O	Data I/O
A11	A[3]	O	System byte address

**Table 21. 256-Ball PBGA Ball Listing (Continued)**

Ball Location	Name	Type	Description
A12	VDDIO	Pad power	Digital I/O power, 3.3V
A13	A[6]	O	System byte address
A14	MOSCOU	O	Main oscillator out
A15	VDDOSC	Oscillator power	Oscillator power in, 2.5V
A16	VSSIO	Pad ground	I/O ground
B1	nCS[5]	O	Chip select out
B2	VDDIO	Pad power	I/O ground
B3	nCS[3]	O	Chip select out
B4	nMOE	O	ROM, expansion OP enable
B5	VDDIO	Pad power	Digital I/O power, 3.3V
B6	N/C	O	

Table 21. 256-Ball PBGA Ball Listing (Continued)

Ball Location	Name	Type	Description
B7	DD[2]	O	LCD serial display data
B8	CL[1]	O	LCD line clock
B9	VDDCORE	Core power	Digital core power, 2.5V
B10	D[1]	I/O	Data I/O
B11	A[2]	O	System byte address
B12	A[4]	O	System byte address
B13	A[5]	O	System byte address
B14	WAKEUP	I	System wake up input
B15	VDDIO	Pad power	Digital I/O power, 3.3V
B16	nURESET	I	User reset input
C1	VDDIO	Pad power	Digital I/O power, 3.3V
C2	EXPCLK	I	Expansion clock input
C3	VSSIO	Pad ground	I/O ground
C4	VDDIO	Pad power	Digital I/O power, 3.3V
C5	VSSIO	Pad ground	I/O ground
C6	VSSIO	Pad ground	I/O ground
C7	VSSIO	Pad ground	I/O ground
C8	VDDIO	Pad power	Digital I/O power, 3.3V
C9	VSSIO	Pad ground	I/O ground
C10	VSSIO	Pad ground	I/O ground
C11	VSSIO	Pad ground	I/O ground
C12	VDDIO	Pad power	Digital I/O power, 3.3V
C13	VSSIO	Pad ground	I/O ground
C14	VSSIO	Pad ground	I/O ground
C15	nPOR	I	Power-on reset input
C16	nEXTPWR	I	External power supply sense input
D1	WRITE	O	Transfer direction
D2	EXPRDY	I	Expansion port ready input
D3	VSSIO	Pad ground	I/O ground
D4	VDDIO	Pad power	Digital I/O power, 3.3V
D5	nCS[2]	O	Chip select out
D6	nMWE	O	ROM, expansion write enable
D7	N/C	O	
D8	CL[2]	O	LCD pixel clock out
D9	VSSRTC	Core ground	Real time clock ground
D10	D[4]	I/O	Data I/O
D11	nPWRFL	I	Power fail sense input
D12	MOSCIN	I	Main oscillator input
D13	VDDIO	Pad power	Digital I/O power, 3.3V
D14	VSSIO	Pad ground	I/O ground
D15	D[7]	I/O	Data I/O
D16	D[8]	I/O	Data I/O
E1	RXD[2]	I	UART 2 receive data input
E2	PB[7]	I	GPIO port B
E3	TDI	I	JTAG data input
E4	WORD	O	Word access select output
E5	VSSIO	Pad ground	I/O ground
E6	nCS[0]	O	Chip select out

Table 21. 256-Ball PBGA Ball Listing (Continued)

Ball Location	Name	Type	Description
E7	N/C	O	
E8	FRM	O	LCD frame synchronization pulse
E9	A[0]	O	System byte address
E10	D[5]	I/O	Data I/O
E11	VSSOSC	Oscillator ground	PLL ground
E12	VSSIO	Pad ground	I/O ground
E13	nMEDCHG/nBROM	I	Media change interrupt input / internal rom boot enable
E14	VDDIO	Pad power	Digital I/O power, 3.3V
E15	D[9]	I/O	Data I/O
E16	D[10]	I/O	Data I/O
F1	PB[5]	I	GPIO port B
F2	PB[3]	I	GPIO port B
F3	VSSIO	Pad ground	I/O ground
F4	TXD[2]	O	UART 2 transmit data output
F5	RUN/CLKEN	O	Run output / clock enable output
F6	VSSIO	Pad ground	I/O ground
F7	N/C	O	
F8	DD[3]	O	LCD serial display data
F9	A[1]	O	System byte address
F10	D[6]	I/O	Data I/O
F11	VSSRTC	RTC ground	Real time clock ground
F12	BATOK	I	Battery ok input
F13	nBATCHG	I	Battery changed sense input
F14	VSSIO	Pad ground	I/O ground
F15	D[11]	I/O	Data I/O
F16	VDDIO	Pad power	Digital I/O power, 3.3V
G1	PB[1]/PRDY[2]	I	GPIO port B / CL-PS6700 interface signal
G2	VDDIO	Pad power	Digital I/O power, 3.3V
G3	TDO	O	JTAG data out
G4	PB[4]	I	GPIO port B
G5	PB[6]	I	GPIO port B
G6	VSSRTC	Core ground	Real time clock ground
G7	VSSRTC	RTC ground	Real time clock ground
G8	DD[0]	O	LCD serial display data
G9	D[3]	I/O	Data I/O
G10	VSSRTC	RTC ground	Real time clock ground
G11	A[7]	O	System byte address
G12	A[8]	O	System byte address
G13	A[9]	O	System byte address
G14	VSSIO	Pad ground	I/O ground
G15	D[12]	I/O	Data I/O
G16	D[13]	I/O	Data I/O
H1	PA[7]	I	GPIO port A
H2	PA[5]	I	GPIO port A
H3	VSSIO	Pad ground	I/O ground
H4	PA[4]	I	GPIO port A
H5	PA[6]	I	GPIO port A

**Table 21. 256-Ball PBGA Ball Listing (Continued)**

Ball Location	Name	Type	Description
H6	PB[0]/PRDY[1]	I	GPIO port B / CL-PS6700 interface signal
H7	PB[2]	I	GPIO port B
H8	VSSRTC	RTC ground	Real time clock ground
H9	VSSRTC	RTC ground	Real time clock ground
H10	A[10]	O	System byte address
H11	A[11]	O	System byte address
H12	A[12]	O	System byte address
H13	A[13]	O	System byte address
H14	VSSIO	Pad ground	I/O ground
H15	D[14]	I/O	Data I/O
H16	D[15]	I/O	Data I/O
J1	PA[3]	I	GPIO port A
J2	PA[1]	I	GPIO port A
J3	VSSIO	Pad ground	I/O ground
J4	PA[2]	I	GPIO port A
J5	PA[0]	I	GPIO port A
J6	TXD[1]	O	UART 1 transmit data out
J7	CTS	I	UART 1 clear to send input
J8	VSSRTC	RTC ground	Real time clock ground
J9	VSSRTC	RTC ground	Real time clock ground
J10	A[17]	O	System byte address
J11	A[16]	O	System byte address
J12	A[15]	O	System byte address
J13	A[14]	O	System byte address
J14	nTRST	I	JTAG async reset input
J15	D[16]	I/O	Data I/O
J16	D[17]	I/O	Data I/O
K1	LEDDRV	O	IR LED driver
K2	PHDIN	I	Photodiode input
K3	VSSIO	Pad ground	I/O ground
K4	DCD	I	UART 1 data carrier detect
K5	nTEST[1]	I	Test mode select input
K6	EINT[3]	I	External interrupt
K7	VSSRTC	RTC ground	Real time clock ground
K8	ADCIN	I	SSI1 ADC serial input
K9	COL[4]	O	Keyboard scanner column drive
K10	TCLK	I	JTAG clock
K11	D[20]	I/O	Data I/O
K12	D[19]	I/O	Data I/O
K13	D[18]	I/O	Data I/O
K14	VSSIO	Pad ground	I/O ground
K15	VDDIO	Pad power	Digital I/O power, 3.3V
K16	VDDIO	Pad power	Digital I/O power, 3.3V
L1	RXD[1]	I	UART 1 receive data input
L2	DSR	I	UART 1 data set ready input
L3	VDDIO	Pad power	Digital I/O power, 3.3V
L4	nEINT[1]	I	External interrupt input
L5	PE[2]/CLKSEL	I	GPIO port E / clock input mode select

**Table 21. 256-Ball PBGA Ball Listing (Continued)**

Ball Location	Name	Type	Description
L6	VSSRTC	RTC ground	Real time clock ground
L7	PD[0]/LEDFLSH	I/O	GPIO port D / LED blinker output
L8	VSSRTC	Core ground	Real time clock ground
L9	COL[6]	O	Keyboard scanner column drive
L10	D[31]	I/O	Data I/O
L11	VSSRTC	RTC ground	Real time clock ground
L12	A[22]	O	System byte address
L13	A[21]	O	System byte address
L14	VSSIO	Pad ground	I/O ground
L15	A[18]	O	System byte address
L16	A[19]	O	System byte address
M1	nTEST[0]	I	Test mode select input
M2	nEINT[2]	I	External interrupt input
M3	VDDIO	Pad power	Digital I/O power, 3.3V
M4	PE[0]/BOOTSEL[0]	I	GPIO port E / Boot mode select
M5	TMS	I	JTAG mode select
M6	VDDIO	Pad power	Digital I/O power, 3.3V
M7	SSITXFR	I/O	DAI/CODEC/SSI2 frame sync
M8	DRIVE[1]	I/O	PWM drive output
M9	FB[0]	I	PWM feedback input
M10	COL[0]	O	Keyboard scanner column drive
M11	D[27]	I/O	Data I/O
M12	VSSIO	Pad ground	I/O ground
M13	A[23]	O	System byte address
M14	VDDIO	Pad power	Digital I/O power, 3.3V
M15	A[20]	O	System byte address
M16	D[21]	I/O	Data I/O
N1	nEXTFIQ	I	External fast interrupt input
N2	PE[1]/BOOTSEL[1]	I	GPIO port E / boot mode select
N3	VSSIO	Pad ground	I/O ground
N4	VDDIO	Pad power	Digital I/O power, 3.3V
N5	PD[5]	I/O	GPIO port D
N6	PD[2]	I/O	GPIO port D
N7	SSIRXDA	I/O	DAI/CODEC/SSI2 serial data input
N8	ADCCLK	O	SSI1 ADC serial clock
N9	SMPCLK	O	SSI1 ADC sample clock
N10	COL[2]	O	Keyboard scanner column drive
N11	D[29]	I/O	Data I/O
N12	D[26]	I/O	Data I/O
N13	HALFWORD	O	Halfword access select output
N14	VSSIO	Pad ground	I/O ground
N15	D[22]	I/O	Data I/O
N16	D[23]	I/O	Data I/O
P1	VSSRTC	RTC ground	Real time clock ground
P2	RTCOUT	O	Real time clock oscillator output
P3	VSSIO	Pad ground	I/O ground
P4	VSSIO	Pad ground	I/O ground
P5	VDDIO	Pad power	Digital I/O power, 3.3V

Table 21. 256-Ball PBGA Ball Listing (Continued)

Ball Location	Name	Type	Description
P6	VSSIO	Pad ground	I/O ground
P7	VSSIO	Pad ground	I/O ground
P8	VDDIO	Pad power	Digital I/O power, 3.3V
P9	VSSIO	Pad ground	I/O ground
P10	VDDIO	Pad power	Digital I/O power, 3.3V
P11	VSSIO	Pad ground	I/O ground
P12	VSSIO	Pad ground	I/O ground
P13	VDDIO	Pad power	Digital I/O power
P14	VSSIO	Pad ground	I/O ground
P15	D[24]	I/O	Data I/O
P16	VDDIO	Pad power	Digital I/O power, 3.3V
R1	RTCIN	I/O	Real time clock oscillator input
R2	VDDIO	Pad power	Digital I/O power, 3.3V
R3	PD[4]	I/O	GPIO port D
R4	PD[1]	I/O	GPIO port D
R5	SSITXDA	O	DAI/CODEC/SSI2 serial data output
R6	nADCCS	O	SSI1 ADC chip select
R7	VDDIO	Pad power	Digital I/O power, 3.3V
R8	ADCOUT	O	SSI1 ADC serial data output
R9	COL[7]	O	Keyboard scanner column drive
R10	COL[3]	O	Keyboard scanner column drive
R11	COL[1]	O	Keyboard scanner column drive
R12	D[30]	I/O	Data I/O
R13	A[27]	O	System byte address
R14	A[25]	O	System byte address
R15	VDDIO	Pad power	Digital I/O power, 3.3V
R16	A[24]	O	System byte address
T1	VDDRRTC	RTC power	Real time clock power, 2.5V
T2	PD[7]	I/O	GPIO port D
T3	PD[6]	I/O	GPIO port D
T4	PD[3]	I/O	GPIO port D
T5	SSICLK	I/O	DAI/CODEC/SSI2 serial clock
T6	SSIRXFR	–	DAI/CODEC/SSI2 frame sync
T7	VDDCORE	Core power	Core power, 2.5V
T8	DRIVE[0]	I/O	PWM drive output
T9	FB[1]	I	PWM feedback input
T10	COL[5]	O	Keyboard scanner column drive
T11	VDDIO	Pad power	Digital I/O power, 3.3V
T12	BUZ	O	Buzzer drive output
T13	D[28]	I/O	Data I/O
T14	A[26]	O	System byte address
T15	D[25]	I/O	Data I/O
T16	VSSIO	Pad ground	I/O ground

## JTAG Boundary Scan Signal Ordering

**Table 22. JTAG Boundary Scan Signal Ordering**

<b>LQFP Pin No.</b>	<b>TFBGA Ball</b>	<b>PBGA Ball</b>	<b>Signal</b>	<b>Type</b>	<b>Position</b>
1	B3	B1	nCS[5]	O	1
4	A2	C2	EXPCLK	I/O	3
5	B1	E4	WORD	O	6
6	E3	D1	WRITE	O	8
7	C1	F5	RUN/CLKEN	O	10
8	C2	D2	EXPRDY	I	13
9	E2	F4	TXD2	O	14
10	D2	E1	RXD2	I	16
13	F3	E2	PB[7]	I/O	17
14	D1	G5	PB[6]	I/O	20
15	F2	F1	PB[5]	I/O	23
16	G3	G4	PB[4]	I/O	26
17	E1	F2	PB[3]	I/O	29
18	F1	H7	PB[2]	I/O	32
19	G2	G1	PB[1]/PRDY2	I/O	35
20	G1	H6	PB[0]/PRDY1	I/O	38
23	H3	H1	PA[7]	I/O	41
24	H1	H5	PA[6]	I/O	44
25	J3	H2	PA[5]	I/O	47
26	J2	H4	PA[4]	I/O	50
27	J1	J1	PA[3]	I/O	53
28	L3	J4	PA[2]	I/O	56
29	K2	J2	PA[1]	I/O	59
30	K1	J5	PA[0]	I/O	62
31	M3	K1	LEDDR	O	65
32	L2	J6	TXD1	O	67
34	L1	K2	PHDIN	I	69
35	N3	J7	CTS	I	70
36	M2	L1	RXD1	I	71
37	M1	K4	DCD	I	72
38	P3	L2	DSR	I	73
39	N1	K5	nTEST1	I	74
40	N2	M1	nTEST0	I	75
41	R3	K6	EINT3	I	76
42	P1	M2	nEINT2	I	77
43	P2	L4	nEINT1	I	78

Table 22. JTAG Boundary Scan Signal Ordering (Continued)

LQFP Pin No.	TFBGA Ball	PBGA Ball	Signal	Type	Position
44	T3	N1	nEXTFIQ	I	79
45	R1	L5	PE[2]/CLKSEL	I/O	80
46	R2	N2	PE[1]/BOOTSEL1	I/O	83
47	T1	M4	PE[0]/BOOTSEL0	I/O	86
53	T2	T2	PD[7]	I/O	89
54	V4	T3	PD[6]	I/O	92
55	W4	N5	PD[5]	I/O	95
56	Y4	R3	PD[4]	I/O	98
59	V5	T4	PD[3]	I/O	101
60	W5	N6	PD[2]	I/O	104
61	Y5	R4	PD[1]	I/O	107
62	V6	L7	PD[0]/LEDFLSH	O	110
68	W6	T6	SSIRXFR	I/O	122
69	Y6	K8	ADCIN	I	125
70	W8	R6	nADCCS	O	126
75	Y8	M8	DRIVE1	I/O	128
76	V9	T8	DRIVE0	I/O	131
77	W10	N8	ADCCLK	O	134
78	Y10	R8	ADCOUT	O	136
79	V11	N9	SMPCLK	O	138
80	W11	T9	FB1	I	140
82	Y11	M9	FB0	I	141
83	Y12	R9	COL7	O	142
84	W12	L9	COL6	O	144
85	V12	T10	COL5	O	146
86	Y13	K9	COL4	O	148
87	W13	R10	COL3	O	150
88	V13	N10	COL2	O	152
91	Y14	R11	COL1	O	154
92	W14	M10	COL0	O	156
93	A1	T12	BUZ	O	158
94	V14	L10	D[31]	I/O	160
95	Y15	R12	D[30]	I/O	163
96	W15	N11	D[29]	I/O	166
97	V15	T13	D[28]	I/O	169
99	Y16	R13	A[27]	Out	172
100	W16	M11	D[27]	I/O	174
101	V16	T14	A[26]	O	177

**Table 22. JTAG Boundary Scan Signal Ordering (Continued)**

<b>LQFP Pin No.</b>	<b>TFBGA Ball</b>	<b>PBGA Ball</b>	<b>Signal</b>	<b>Type</b>	<b>Position</b>
102	Y17	N12	D[26]	I/O	179
103	W17	R14	A[25]	O	182
104	Y18	T15	D[25]	I/O	184
105	V17	N13	HALFWORD	O	187
106	W18	R16	A[24]	O	189
109	Y19	P15	D[24]	I/O	191
110	W20	M13	A[23]	O	194
111	U18	N16	D[23]	I/O	196
112	V20	L12	A[22]	O	199
113	U19	N15	D[22]	I/O	201
114	U20	L13	A[21]	O	204
115	T19	M16	D[21]	I/O	206
117	T20	M15	A[20]	O	209
118	R19	K11	D[20]	I/O	211
119	R20	L16	A[19]	O	214
120	T18	K12	D[19]	I/O	216
121	P19	L15	A[18]	O	219
122	P20	K13	D[18]	I/O	221
126	R18	J10	A[17]	O	224
127	N19	J16	D[17]	I/O	226
128	N20	J11	A[16]	O	229
129	P18	J15	D[16]	I/O	231
130	M19	J12	A[15]	O	234
131	N18	H16	D[15]	I/O	236
132	L20	J13	A[14]	O	239
133	L19	H15	D[14]	I/O	241
134	M18	H13	A[13]	O	244
135	K20	G16	D[13]	I/O	246
136	K19	H12	A[12]	O	249
137	K18	G15	D[12]	I/O	251
138	J20	H11	A[11]	O	254
141	J19	F15	D[11]	I/O	256
142	H20	H10	A[10]	O	259
143	H19	E16	D[10]	I/O	261
144	J18	G13	A[9]	O	264
145	K3	E15	D[9]	I/O	266
146	Y3	G12	A[8]	O	269
147	G20	D16	D[8]	I/O	271

Table 22. JTAG Boundary Scan Signal Ordering (Continued)

LQFP Pin No.	TFBGA Ball	PBGA Ball	Signal	Type	Position
148	H18	G11	A[7]	O	274
150	F20	D15	D[7]	I/O	276
151	G19	F13	nBATCHG	I	279
152	E20	C16	nEXTPWR	I	280
153	F19	F12	BATOK	I	281
154	G18	C15	nPOR	I	282
155	D20	E13	nMEDCHG/nBROM	I	283
156	F18	B16	nURESET	I	284
161	D19	B14	WAKEUP	I	285
162	E19	D11	nPWRFL	I	286
163	C19	A13	A[6]	O	287
164	C20	F10	D[6]	I/O	289
165	E18	B13	A[5]	O	292
166	B20	E10	D[5]	I/O	294
169	B16	B12	A[4]	O	297
170	A16	D10	D[4]	I/O	299
171	C15	A11	A[3]	O	302
172	B15	G9	D[3]	I/O	304
173	A15	B11	A[2]	O	307
175	C14	A10	D[2]	I/O	309
176	B14	F9	A[1]	O	312
177	A14	B10	D[1]	I/O	314
178	C13	E9	A[0]	O	317
179	B13	A9	D[0]	I/O	319
184	A13	D8	CL2	O	322
185	C12	B8	CL1	O	324
186	B12	E8	FRM	O	326
187	A12	A7	M	O	328
188	C11	F8	DD[3]	I/O	330
189	B11	B7	DD[2]	I/O	333
191	B10	A6	DD[1]	I/O	336
192	A10	G8	DD[0]	I/O	339
193	A9	B6	N/C	O	342
194	B9	D7	N/C	O	344
195	C9	A5	N/C	I/O	346
196	A8	E7	N/C	I/O	349
199	B8	F7	N/C	I/O	352
200	C8	A4	N/C	I/O	355

Table 22. JTAG Boundary Scan Signal Ordering (Continued)

LQFP Pin No.	TFBGA Ball	PBGA Ball	Signal	Type	Position
201	A7	D6	nMWE	O	358
202	B7	B4	nMOE	O	360
204	C7	E6	nCS[0]	O	362
205	A6	A3	nCS[1]	O	364
206	B6	D5	nCS[2]	O	366
207	C6	B3	nCS[3]	O	368
208	A5	A2	nCS[4]	O	370

- 1) See EP7309 Users' Manual for pin naming / functionality.
- 2) For each pad, the JTAG connection ordering is input, output, then enable as applicable.

## CONVENTIONS

This section presents acronyms, abbreviations, units of measurement, and conventions used in this data sheet.

### Acronyms and Abbreviations

Table 23 lists abbreviations and acronyms used in this data sheet.

Table 23. Acronyms and Abbreviations

Acronym/ Abbreviation	Definition
A/D	analog-to-digital
ADC	analog-to-digital converter
CODEC	coder / decoder
D/A	digital-to-analog
DMA	direct-memory access
EPB	embedded peripheral bus
FCS	frame check sequence
FIFO	first in / first out
FIQ	fast interrupt request
GPIO	general purpose I/O
ICT	in circuit test
IR	infrared
IRQ	standard interrupt request
IrDA	Infrared Data Association
JTAG	Joint Test Action Group
LCD	liquid crystal display
LED	light-emitting diode
LQFP	low profile quad flat pack
LSB	least significant bit
MIPS	millions of instructions per second
MMU	memory management unit
MSB	most significant bit
PBGA	plastic ball grid array
PCB	printed circuit board
PDA	personal digital assistant
PLL	phase locked loop
p/u	pull-up resistor
RISC	reduced instruction set computer
RTC	Real-Time Clock
SIR	slow (9600–115.2 kbps) infrared
SRAM	static random access memory
SSI	synchronous serial interface

Table 23. Acronyms and Abbreviations (Continued)

Acronym/ Abbreviation	Definition
TAP	test access port
TLB	translation lookaside buffer
UART	universal asynchronous receiver

### Units of Measurement

Table 24. Unit of Measurement

Symbol	Unit of Measure
°C	degree Celsius
fs	sample frequency
Hz	hertz (cycle per second)
kbps	kilobits per second
KB	kilobyte (1,024 bytes)
kHz	kilohertz
kΩ	kilohm
Mbps	megabits (1,048,576 bits) per second
MB	megabyte (1,048,576 bytes)
MBps	megabytes per second
MHz	megahertz (1,000 kilohertz)
μA	microampere
μF	microfarad
μW	microwatt
μs	microsecond (1,000 nanoseconds)
mA	milliampere
mW	milliwatt
ms	millisecond (1,000 microseconds)
ns	nanosecond
V	volt
W	watt

## General Conventions

Hexadecimal numbers are presented with all letters in uppercase and a lowercase “h” appended or with a 0x at the beginning. For example, 0x14 and 03CAh are hexadecimal numbers. Binary numbers are enclosed in single quotation marks when in text (for example, ‘11’ designates a binary number). Numbers not indicated by an “h”, 0x or quotation marks are decimal.

Registers are referred to by acronym, with bits listed in brackets separated by a colon (:) (for example, CODR[7:0]), and are described in the EP7309 User’s Manual. The use of “TBD” indicates values that are “to be determined,” “n/a” designates “not available,” and “n/c” indicates a pin that is a “no connect.”

## Pin Description Conventions

Abbreviations used for signal directions are listed in Table 25.

Table 25. Pin Description Conventions

Abbreviation	Direction
I	Input
O	Output
I/O	Input or Output

## Ordering Information

Model	Package	Temperature
EP7309-CB	256-pin BGA, 17mm X 17mm	0 to +70 °C
EP7309-CBZ (Lead Free)		
EP7309-CV	208-pin LQFP.	
EP7309-CVZ (Lead Free)		
EP7309-IB	256-pin BGA, 17mm X 17mm	-40 to +85 °C.
EP7309-IBZ (Lead Free)		
EP7309-IR	204-pin BGA, 13mm X 13mm.	

## Environmental, Manufacturing, & Handling Information

Model Number	Peak Reflow Temp	MSL Rating*	Max Floor Life
EP7309-CB	225 °C	3	7 Days
EP7309-CBZ (Lead Free)	260 °C		
EP7309-CV	225 °C		
EP7309-CVZ (Lead Free)	260 °C		
EP7309-IB	225 °C		
EP7309-IBZ (Lead Free)	260 °C		
EP7309-IR	225 °C		

\* MSL (Moisture Sensitivity Level) as specified by IPC/JEDEC J-STD-020.

## Revision History

Revision	Date	Changes
PP1	NOV 2003	First preliminary release.
F1	AUG 2005	Updated SDRAM timing. Added MSL data.

---

### Contacting Cirrus Logic Support

For all product questions and inquiries contact a Cirrus Logic Sales Representative.

To find the one nearest to you go to [www.cirrus.com](http://www.cirrus.com)

---

#### IMPORTANT NOTICE

Cirrus Logic, Inc. and its subsidiaries ("Cirrus") believe that the information contained in this document is accurate and reliable. However, the information is subject to change without notice and is provided "AS IS" without warranty of any kind (express or implied). Customers are advised to obtain the latest version of relevant information to verify, before placing orders, that information being relied on is current and complete. All products are sold subject to the terms and conditions of sale supplied at the time of order acknowledgment, including those pertaining to warranty, indemnification, and limitation of liability. No responsibility is assumed by Cirrus for the use of this information, including use of this information as the basis for manufacture or sale of any items, or for infringement of patents or other rights of third parties. This document is the property of Cirrus and by furnishing this information, Cirrus grants no license, express or implied under any patents, mask work rights, copyrights, trademarks, trade secrets or other intellectual property rights. Cirrus owns the copyrights associated with the information contained herein and gives consent for copies to be made of the information only for use within your organization with respect to Cirrus integrated circuits or other products of Cirrus. This consent does not extend to other copying such as copying for general distribution, advertising or promotional purposes, or for creating any work for resale.

CERTAIN APPLICATIONS USING SEMICONDUCTOR PRODUCTS MAY INVOLVE POTENTIAL RISKS OF DEATH, PERSONAL INJURY, OR SEVERE PROPERTY OR ENVIRONMENTAL DAMAGE ("CRITICAL APPLICATIONS"). CIRRUS PRODUCTS ARE NOT DESIGNED, AUTHORIZED OR WARRANTED FOR USE IN AIRCRAFT SYSTEMS, MILITARY APPLICATIONS, PRODUCTS SURGICALLY IMPLANTED INTO THE BODY, AUTOMOTIVE SAFETY OR SECURITY DEVICES, LIFE SUPPORT PRODUCTS OR OTHER CRITICAL APPLICATIONS. INCLUSION OF CIRRUS PRODUCTS IN SUCH APPLICATIONS IS UNDERSTOOD TO BE FULLY AT THE CUSTOMER'S RISK AND CIRRUS DISCLAIMS AND MAKES NO WARRANTY, EXPRESS, STATUTORY OR IMPLIED, INCLUDING THE IMPLIED WARRANTIES OF MERCHANTABILITY AND FITNESS FOR PARTICULAR PURPOSE, WITH REGARD TO ANY CIRRUS PRODUCT THAT IS USED IN SUCH A MANNER. IF THE CUSTOMER OR CUSTOMER'S CUSTOMER USES OR PERMITS THE USE OF CIRRUS PRODUCTS IN CRITICAL APPLICATIONS, CUSTOMER AGREES, BY SUCH USE, TO FULLY INDEMNIFY CIRRUS, ITS OFFICERS, DIRECTORS, EMPLOYEES, DISTRIBUTORS AND OTHER AGENTS FROM ANY AND ALL LIABILITY, INCLUDING ATTORNEYS' FEES AND COSTS, THAT MAY RESULT FROM OR ARISE IN CONNECTION WITH THESE USES.

Cirrus Logic, Cirrus, and the Cirrus Logic logo designs are trademarks of Cirrus Logic, Inc. All other brand and product names in this document may be trademarks or service marks of their respective owners.

SPI is a trademark of Motorola, Inc.

Microwire is a trademark of National Semiconductor Corporation.

LINUX is a registered trademark of Linus Torvalds.

Microsoft Windows and Microsoft are registered trademarks of Microsoft Corporation.

## Looking for pricing, stock, or lifecycle information?

Click below to explore more details on WIN SOURCE:

 [View EP7309-CV](#) on WIN SOURCE

 [Cirrus Logic Inc.](#) Information

## Optimize Your Supply Chain with WIN SOURCE Solutions

-  Global Sourcing Solution
-  Obsolete Management
-  Cost Control Management
-  Shortage Management
-  Alternative Solution
-  Excess Inventory Management