

bq2404x 1A, Single-Input, Single Cell Li-Ion and Li-Pol Battery Charger With Auto Start

1 Features

- Charging
 - 1% Charge Voltage Accuracy
 - 10% Charge Current Accuracy
 - Pin Selectable USB 100mA and 500mA Maximum Input Current Limit
 - Programmable Termination and Precharge Threshold, bq24040 and bq24045
 - High voltage (4.35V) Chemistry Support with bq24045
- Protection
 - 30V Input Rating; with 6.6V or 7.1V Input Overvoltage Protection
 - Input Voltage Dynamic Power Management
 - 125°C Thermal Regulation; 150°C Thermal Shutdown Protection
 - OUT Short-Circuit Protection and ISET short detection
 - Operation over JEITA Range via Battery NTC – 1/2 Fast-Charge-Current at Cold, 4.06V at Hot, bq24040 and bq24045
 - Fixed 10 Hour Safety Timer, bq24040 and bq24045
- System
 - Automatic Termination and Timer Disable Mode (TTDM) for Absent Battery Pack With Thermistor, bq24040 and bq24045
 - Status Indication – Charging/Done
 - Available in Small 2x2mm² DFN-10 Package
 - Integrated Auto Start Function for Production Line Testing, bq24041

2 Applications

- Smart Phones
- PDAs
- MP3 Players
- Low-Power Handheld Devices

3 Description

The bq2404x series of devices are highly integrated Li-Ion and Li-Pol linear chargers devices targeted at space-limited portable applications. The devices operate from either a USB port or AC adapter. The high input voltage range with input overvoltage protection supports low-cost unregulated adapters.

The bq2404x has a single power output that charges the battery. A system load can be placed in parallel with the battery as long as the average system load does not keep the battery from charging fully during the 10 hour safety timer.

The battery is charged in three phases: conditioning, constant current and constant voltage. In all charge phases, an internal control loop monitors the IC junction temperature and reduces the charge current if an internal temperature threshold is exceeded.

The charger power stage and charge current sense functions are fully integrated. The charger function has high accuracy current and voltage regulation loops, charge status display, and charge termination. The pre-charge current and termination current threshold are programmed via an external resistor on the bq24040 and bq24045. The fast charge current value is also programmable via an external resistor.

Device Information⁽¹⁾

PART NUMBER	PACKAGE	BODY SIZE (NOM)
bq24040	WSON (10)	2.00 mm x 2.00 mm
bq24041	WSON (10)	2.00 mm x 2.00 mm
bq24045	WSON (10)	2.00 mm x 2.00 mm

(1) For all available packages, see the orderable addendum at the end of the data sheet.

Simplified Schematic

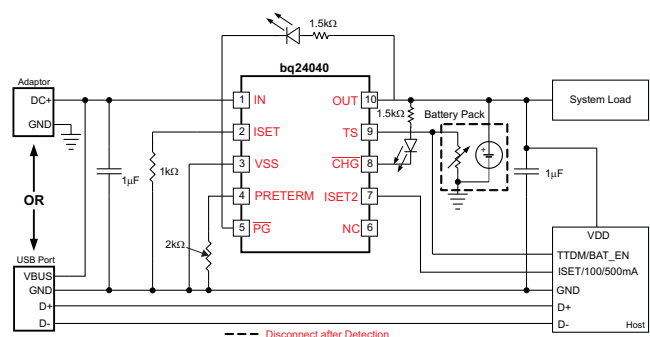

Table of Contents

1 Features	1	8.2 Functional Block Diagram	12
2 Applications	1	8.3 Feature Description	13
3 Description	1	8.4 Device Functional Modes	16
4 Revision History	2	9 Application and Implementation	21
5 Device Comparison	4	9.1 Application Information	21
6 Pin Configuration and Functions	4	9.2 Typical Applications	21
7 Specifications	5	10 Power Supply Recommendations	29
7.1 Absolute Maximum Ratings	5	11 Layout	29
7.2 ESD Ratings	5	11.1 Layout Guidelines	29
7.3 Recommended Operating Conditions	5	11.2 Layout Example	29
7.4 Thermal Information	6	12 Device and Documentation Support	30
7.5 Electrical Characteristics	6	12.1 Documentation Support	30
7.6 Timing Requirements	9	12.2 Related Links	30
7.7 Typical Operational Characteristics (Protection Circuits Waveforms)	10	12.3 Trademarks	30
8 Detailed Description	11	12.4 Electrostatic Discharge Caution	30
8.1 Overview	11	12.5 Glossary	30
		13 Mechanical, Packaging, and Orderable Information	30

4 Revision History

NOTE: Page numbers for previous revisions may differ from page numbers in the current version.

Changes from Revision E (February 2014) to Revision F

Page

• Changed the <i>Device Information</i> table header information, and removed the package designation from the device number	1
• Changed the <i>Terminal Configuration and Functions</i> To: Pin Configuration and Functions	4
• The storage temperature range has been moved to the Absolute Maximum Ratings⁽¹⁾	5
• Changed the <i>Handling Ratings</i> table To: ESD Ratings and updated the guidelines	5
• Added the package family to the column heading in the Thermal Information	6
• Added the NOTE to the Application and Implementation	21

Changes from Revision D (March 2013) to Revision E

Page

• Added <i>Handling Ratings</i> table, <i>Feature Description</i> section, <i>Device Functional Modes</i> section, <i>Application and Implementation</i> section, <i>Power Supply Recommendations</i> section, <i>Layout</i> section, <i>Device and Documentation Support</i> section, and <i>Mechanical, Packaging, and Orderable Information</i> section	1
• Changed the Dissipation Rating table to the Thermal Information	6
• Changed $V_{O_HT(REG)}$ in the Electrical Characteristics table to include new values bq24045	7
• Added the Timing Requirements table	9
• Deleted the last sentence in the first paragraph of the TS (bq24040/5) section	18
• Added the Application Performance Curves	24

Changes from Revision C (February 2013) to Revision D	Page
• Changed Feature From: Fixed 10 Hour Safety Timer To: Fixed 10 Hour Safety Timer, bq24040 and bq24045	1
• Changed the OUT terminal <i>DESCRIPTION</i>	4
• Changed R _{ISET} NOM value in the ROC table From: 49.9 kΩ To: 10.8 kΩ	5
• Changed R _{ISET_SHORT} test conditions From: R _{ISET} : 600Ω → 250Ω To: R _{ISET} : 540Ω → 250Ω	6
• Changed I _{OUT_CL} test conditions From: R _{ISET} : 600Ω → 250Ω To: R _{ISET} : 540Ω → 250Ω	6
• Deleted: Internally Set: bq24041 from the TERMINATION section	7
• Added bq24040 and bq24045 only to the BATTERY CHARGING TIMERS AND FAULT TIMERS section	9
• Changed text in the ISET section From: "maximum current between 1.1A and 1.35A" To: "maximum current between 1.05A and 1.4A"	17
• Changed the Timers section	19
• Deleted: I _{OUT_TERM} = 54mA from the Typical Application Circuit: bq24041, with ASI and ASO conditions	27

Changes from Revision B (June 2012) to Revision C	Page
• Added device bq24045	1
• Added additional K _{ISET} information to the Electrical Characteristics table	7
• Added graph - Load Regulation	10
• Added graph - Line Regulation	10

Changes from Revision A (September 2009) to Revision B	Page
• Changed all occurrences of Li-Ion To: Li-Ion and Li-Pol	1

Changes from Original (August 2009) to Revision A	Page
• Changed the status of the devices From: Product Preview To: Production Data	1

5 Device Comparison

PART #	V _{O(REG)}	V _{OVP}	PreTerm	ASI/ASO	TS/BAT_EN	PG	PACKAGE
bq24040	4.20 V	6.6 V	Yes	No	TS (JEITA)	Yes	10 terminal 2 x 2mm ² DFN
bq24041	4.20 V	7.1 V	No	Yes	$\overline{\text{BAT_EN}}$ Termination Disabled	Yes	10 terminal 2 x 2mm ² DFN
bq24045	4.35V	6.6V	Yes	No	TS (JEITA)	Yes	10 terminal 2 x 2mm ² DFN

6 Pin Configuration and Functions

**bq24040 and bq24045
DSQ (WSON)
Top View**

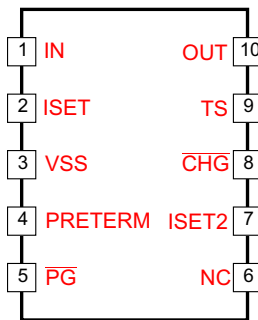

**bq24041
DSQ (WSON)
Top View**

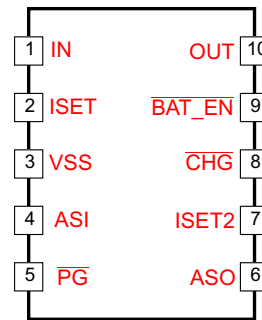

Pin Functions

NAME	bq24040 bq24045	bq24041	I/O	DESCRIPTION
IN	1	1	I	Input power, connected to external DC supply (AC adapter or USB port). Expected range of bypass capacitors 1μF to 10μF, connect from IN to V _{SS} .
OUT	10	10	O	Battery Connection. System Load may be connected. Expected range of bypass capacitors 1μF to 10μF.
PRE-TERM	4	–	I	Programs the Current Termination Threshold (5 to 50% of I _{out} which is set by ISET) and Sets the Pre-Charge Current to twice the Termination Current Level. Expected range of programming resistor is 1k to 10kΩ (2k: I _{pgm} /10 for term; I _{pgm} /5 for precharge)
ISET	2	2	I	Programs the Fast-charge current setting. External resistor from ISET to VSS defines fast charge current value. Range is 10.8k (50mA) to 540Ω (1000mA).
ISET2	7	7	I	Programming the Input/Output Current Limit for the USB or Adaptor source: bq24040/5 => High = 500mA _{max} , Low = ISET, FLOAT = 100mA _{max} . bq24041 => High = 410mA _{max} , Low = ISET, FLOAT = 100mA _{max} .
TS	9 ⁽¹⁾	–	I	Temperature sense terminal connected to bq24040/5 -10k at 25°C NTC thermistor, in the battery pack. Floating T terminal or pulling High puts part in TTDM “Charger” Mode and disable TS monitoring, Timers and Termination. Pulling terminal Low disables the IC. If NTC sensing is not needed, connect this terminal to VSS through an external 10 kΩ resistor. A 250kΩ from TS to ground will prevent IC entering TTDM mode when battery with thermistor is removed.
$\overline{\text{BAT_EN}}$	–	9	I	Charge Enable Input (active low)
VSS	3	3	–	Ground terminal
$\overline{\text{CHG}}$	8	8	O	Low (FET on) indicates charging and Open Drain (FET off) indicates no Charging or Charge complete.
$\overline{\text{PG}}$	5	5	O	Low (FET on) indicates the input voltage is above UVLO and the OUT (battery) voltage.
ASI	–	4	I	Auto start External input. Internal 200kΩ pull-down.
ASO	–	6	O	Auto Start Logic Output
NC	6	–	NA	Do not make a connection to this terminal (for internal use) – Do not route through this terminal
Thermal PAD and Package	Pad 2x2mm ²	Pad 2x2mm ²	–	There is an internal electrical connection between the exposed thermal pad and the VSS terminal of the device. The thermal pad must be connected to the same potential as the VSS terminal on the printed circuit board. Do not use the thermal pad as the primary ground input for the device. VSS terminal must be connected to ground at all times

(1) Spins have different terminal definitions

7 Specifications

7.1 Absolute Maximum Ratings⁽¹⁾

over operating free-air temperature range (unless otherwise noted)

		MIN	MAX	UNIT
Input Voltage	IN (with respect to VSS)	–0.3	30	V
	OUT (with respect to VSS)	–0.3	7	V
	PRE-TERM, ISET, ISET2, TS, $\overline{\text{CHG}}$, $\overline{\text{PG}}$, ASI, ASO (with respect to VSS)	–0.3	7	V
Input Current	IN		1.25	A
Output Current (Continuous)	OUT		1.25	A
Output Sink Current	$\overline{\text{CHG}}$		15	mA
T _J	Junction temperature	–40	150	°C
T _{STG}	Storage temperature	–65	150	°C

- (1) Stresses beyond those listed under absolute maximum ratings may cause permanent damage to the device. These are stress ratings only, and functional operation of the device at these or any other conditions beyond those indicated under recommended operating conditions is not implied. Exposure to absolute-maximum-rated conditions for extended periods may affect device reliability. All voltage values are with respect to the network ground terminal unless otherwise noted.

7.2 ESD Ratings

		VALUE	UNIT
V _(ESD)	Electrostatic discharge ⁽¹⁾	Human-body model (HBM), per ANSI/ESDA/JEDEC JS-001 ⁽²⁾	±3000
		Charged-device model (CDM), per JEDEC specification JESD22-C101 ⁽³⁾	±1500

- (1) The test was performed on IC terminals that may potentially be exposed to the customer at the product level. The bq2404x IC requires a minimum of the listed capacitance, external to the IC, to pass the ESD test. The D+ D- lines require clamp diodes such as CM1213A-02SR from CMD to protect the IC for this testing.
- (2) JEDEC document JEP155 states that 500-V HBM allows safe manufacturing with a standard ESD control process.
- (3) JEDEC document JEP157 states that 250-V CDM allows safe manufacturing with a standard ESD control process.

7.3 Recommended Operating Conditions⁽¹⁾

		MIN	NOM	UNIT
V _{IN}	IN voltage range	3.5	28	V
	IN operating voltage range, Restricted by V _{DPM} and V _{OVp}	4.45	6.45	V
I _{IN}	Input current, IN terminal		1	A
I _{OUT}	Current, OUT terminal		1	A
T _J	Junction temperature	0	125	°C
R _{PRE-TERM}	Programs precharge and termination current thresholds	1	10	kΩ
R _{ISET}	Fast-charge current programming resistor	0.540	10.8	kΩ
R _{TS}	10k NTC thermistor range without entering $\overline{\text{BAT_EN}}$ or TTDM	1.66	258	kΩ

- (1) Operation with V_{IN} less than 4.5V or in drop-out may result in reduced performance.

7.4 Thermal Information

THERMAL METRIC ⁽¹⁾		DSQ (WSON)	UNIT
		10 PINS	
θ_{JA}	Junction-to-ambient thermal resistance	63.5	°C/W
θ_{JCTop}	Junction-to-case (top) thermal resistance	79.5	
θ_{JB}	Junction-to-board thermal resistance	33.9	
Ψ_{JT}	Junction-to-top characterization parameter	7.8	
Ψ_{JB}	Junction-to-board characterization parameter	34.3	
θ_{JCbot}	Junction-to-case (bottom) thermal resistance	7.5	

(1) For more information about traditional and new thermal metrics, see the *IC Package Thermal Metrics* application report, [SPRA953](#).

7.5 Electrical Characteristics

Over junction temperature range $0^{\circ}\text{C} \leq T_J \leq 125^{\circ}\text{C}$ and recommended supply voltage (unless otherwise noted)

PARAMETER		TEST CONDITIONS	MIN	TYP	MAX	UNIT
INPUT						
UVLO	Undervoltage lock-out Exit	V_{IN} : 0V → 4V Update based on sim/char	3.15	3.3	3.45	V
V_{HYS_UVLO}	Hysteresis on V_{UVLO_RISE} falling	V_{IN} : 4V → 0V, $V_{UVLO_FALL} = V_{UVLO_RISE} - V_{HYS_UVLO}$	175	227	280	mV
V_{IN_DT}	Input power good detection threshold is $V_{OUT} + V_{IN_DT}$	(Input power good if $V_{IN} > V_{OUT} + V_{IN_DT}$); $V_{OUT} = 3.6V$, V_{IN} : 3.5V → 4V	30	80	145	mV
V_{HYS_INDT}	Hysteresis on V_{IN_DT} falling	$V_{OUT} = 3.6V$, V_{IN} : 4V → 3.5V		31		mV
V_{OVP}	Input over-voltage protection threshold	V_{IN} : 5V → 12V (bq24040, bq24045)	6.5	6.65	6.8	V
		V_{IN} : 5V → 12V (bq24041)	6.9	7.1	7.3	
V_{HYS_OVP}	Hysteresis on OVP	V_{IN} : 11V → 5V		95		mV
V_{IN_DPM}	USB/Adaptor low input voltage protection. Restricts Iout at V_{IN_DPM}	Feature active in USB mode; Limit Input Source Current to 50mA; $V_{OUT} = 3.5V$; $R_{ISET} = 825\Omega$	4.34	4.4	4.46	V
		Feature active in Adaptor mode; Limit Input Source Current to 50mA; $V_{OUT} = 3.5V$; $R_{ISET} = 825\Omega$	4.24	4.3	4.46	
$I_{IN_USB_CL}$	USB input I-Limit 100mA	$ISET2 = \text{Float}$; $R_{ISET} = 825\Omega$	85	92	100	mA
	USB input I-Limit 500mA, bq24040, bq24045	$ISET2 = \text{High}$; $R_{ISET} = 825\Omega$	430	462	500	
	USB input I-Limit 380mA, bq24041	$ISET2 = \text{High}$; $R_{ISET} = 825\Omega$	350	386	420	
ISET SHORT CIRCUIT TEST						
R_{ISET_SHORT}	Highest Resistor value considered a fault (short). Monitored for Iout>90mA	R_{ISET} : 540Ω → 250Ω, Iout latches off. Cycle power to Reset.	280		500	Ω
I_{OUT_CL}	Maximum OUT current limit Regulation (Clamp)	$V_{IN} = 5V$, $V_{OUT} = 3.6V$, $V_{ISET2} = \text{Low}$, R_{ISET} : 540Ω → 250Ω, Iout latches off after t_{DGL_SHORT}	1.05		1.4	A
BATTERY SHORT PROTECTION						
$V_{OUT(SC)}$	OUT terminal short-circuit detection threshold/ precharge threshold	V_{out} : 3V → 0.5V, no deglitch	0.75	0.8	0.85	V
$V_{OUT(SC_HYS)}$	OUT terminal Short hysteresis	Recovery $\geq V_{OUT(SC)} + V_{OUT(SC_HYS)}$; Rising, no Deglitch		77		mV
$I_{OUT(SC)}$	Source current to OUT terminal during short-circuit detection		10	15	20	mA
QUIESCENT CURRENT						
$I_{OUT(PDOWN)}$	Battery current into OUT terminal	$V_{IN} = 0V$			1	μA
$I_{OUT(DONE)}$	OUT terminal current, charging terminated	$V_{IN} = 6V$, $V_{OUT} > V_{OUT(REG)}$			6	
$I_{IN(STDBY)}$	Standby current into IN terminal	TS = LO, $V_{IN} \leq 6V$			125	μA
I_{CC}	Active supply current, IN terminal	TS = open, $V_{IN} = 6V$, TTDM – no load on OUT terminal, $V_{OUT} > V_{OUT(REG)}$, IC enabled		0.8	1	mA

Electrical Characteristics (continued)

 Over junction temperature range $0^{\circ}\text{C} \leq T_J \leq 125^{\circ}\text{C}$ and recommended supply voltage (unless otherwise noted)

PARAMETER		TEST CONDITIONS	MIN	TYP	MAX	UNIT
BATTERY CHARGER FAST-CHARGE						
$V_{\text{OUT(REG)}}$	Battery regulation voltage	$V_{\text{IN}} = 5.5\text{V}$, $I_{\text{OUT}} = 25\text{mA}$, ($V_{\text{TS-45}^{\circ}\text{C}} \leq V_{\text{TS}} \leq V_{\text{TS-0}^{\circ}\text{C}}$, bq24040)	4.16	4.2	4.23	V
		$V_{\text{IN}} = 5.5\text{V}$, $I_{\text{OUT}} = 25\text{mA}$, ($V_{\text{TS-45}^{\circ}\text{C}} \leq V_{\text{TS}} \leq V_{\text{TS-0}^{\circ}\text{C}}$, bq24045)	4.30	4.35	4.40	
$V_{\text{O-HT(REG)}}$	Battery hot regulation Voltage	$V_{\text{IN}} = 5.5\text{V}$, $I_{\text{OUT}} = 25\text{mA}$, ($V_{\text{TS-45}^{\circ}\text{C}} \leq V_{\text{TS}} \leq V_{\text{TS-0}^{\circ}\text{C}}$, bq24040)	4.02	4.06	4.1	V
		$V_{\text{IN}} = 5.5\text{V}$, $I_{\text{OUT}} = 25\text{mA}$, ($V_{\text{TS-45}^{\circ}\text{C}} \leq V_{\text{TS}} \leq V_{\text{TS-0}^{\circ}\text{C}}$, bq24045)	4.16	4.2	4.23	
$I_{\text{OUT(RANGE)}}$	Programmed Output "fast charge" current range	$V_{\text{OUT(REG)}} > V_{\text{OUT}} > V_{\text{LOWV}}$; $V_{\text{IN}} = 5\text{V}$, ISET2=Lo, $R_{\text{ISET}} = 540$ to $10.8\text{k}\Omega$	10		1000	mA
$V_{\text{DO(IN-OUT)}}$	Drop-Out, $V_{\text{IN}} - V_{\text{OUT}}$	Adjust V_{IN} down until $I_{\text{OUT}} = 0.5\text{A}$, $V_{\text{OUT}} = 4.15\text{V}$, $R_{\text{ISET}} = 540$, ISET2 = Lo (adaptor mode); $T_J \leq 100^{\circ}\text{C}$		325	500	mV
I_{OUT}	Output "fast charge" formula	$V_{\text{OUT(REG)}} > V_{\text{OUT}} > V_{\text{LOWV}}$; $V_{\text{IN}} = 5\text{V}$, ISET2 = Lo		$K_{\text{ISET}}/R_{\text{ISET}}$		A
K_{ISET}	Fast charge current factor	$R_{\text{ISET}} = K_{\text{ISET}}/I_{\text{OUT}}$; $50 < I_{\text{OUT}} < 1000$ mA	510	540	570	A Ω
		$R_{\text{ISET}} = K_{\text{ISET}}/I_{\text{OUT}}$; $25 < I_{\text{OUT}} < 50$ mA	480	527	600	
		$R_{\text{ISET}} = K_{\text{ISET}}/I_{\text{OUT}}$; $10 < I_{\text{OUT}} < 25$ mA	350	520	680	
K_{ISET}	Fast charge current factor (bq24045)	$R_{\text{ISET}} = K_{\text{ISET}}/I_{\text{OUT}}$; $50 < I_{\text{OUT}} < 1000$ mA	510	560	585	A Ω
		$R_{\text{ISET}} = K_{\text{ISET}}/I_{\text{OUT}}$; $25 < I_{\text{OUT}} < 50$ mA	480	557	596	
		$R_{\text{ISET}} = K_{\text{ISET}}/I_{\text{OUT}}$; $10 < I_{\text{OUT}} < 25$ mA	350	555	680	
PRECHARGE – SET BY PRE-TERM terminal: bq24040 / bq24045; Internally Set: bq24041						
V_{LOWV}	Pre-charge to fast-charge transition threshold		2.4	2.5	2.6	V
$I_{\text{PRE-TERM}}$	See the Termination Section					
$\%_{\text{PRECHG}}$	Pre-charge current, default setting	$V_{\text{OUT}} < V_{\text{LOWV}}$; $R_{\text{ISET}} = 1080\Omega$; bq24040: R_{PRE-TERM}= High Z ; bq24041: Internally Fixed	18	20	22	$\%I_{\text{OUT-CC}}$
	Pre-charge current formula	$R_{\text{PRE-TERM}} = K_{\text{PRE-CHG}} (\Omega/\%) \times \%_{\text{PRE-CHG}} (\%)$		$R_{\text{PRE-TERM}}/K_{\text{PRE-CHG}}\%$		
$K_{\text{PRE-CHG}}$	% Pre-charge Factor	$V_{\text{OUT}} < V_{\text{LOWV}}$, $V_{\text{IN}} = 5\text{V}$, $R_{\text{PRE-TERM}} = 2\text{k}$ to $10\text{k}\Omega$; $R_{\text{ISET}} = 1080\Omega$, $R_{\text{PRE-TERM}} = K_{\text{PRE-CHG}} \times \%_{\text{FAST-CHG}}$, where $\%_{\text{FAST-CHG}}$ is 20 to 100%	90	100	110	$\Omega/\%$
		$V_{\text{OUT}} < V_{\text{LOWV}}$, $V_{\text{IN}} = 5\text{V}$, $R_{\text{PRE-TERM}} = 1\text{k}$ to $2\text{k}\Omega$; $R_{\text{ISET}} = 1080\Omega$, $R_{\text{PRE-TERM}} = K_{\text{PRE-CHG}} \times \%_{\text{FAST-CHG}}$, where $\%_{\text{FAST-CHG}}$ is 10% to 20%	84	100	117	$\Omega/\%$
TERMINATION – SET BY PRE-TERM terminal: bq24040 / bq24045						
$\%_{\text{TERM}}$	Termination Threshold Current, default setting	$V_{\text{OUT}} > V_{\text{RCH}}$; $R_{\text{ISET}} = 1\text{k}$; bq24040 / bq24045: R_{PRE-TERM}= High Z	9	10	11	$\%I_{\text{OUT-CC}}$
	Termination Current Threshold Formula, bq24040 / bq24045	$R_{\text{PRE-TERM}} = K_{\text{TERM}} (\Omega/\%) \times \%_{\text{TERM}} (\%)$		$R_{\text{PRE-TERM}}/K_{\text{TERM}}$		
K_{TERM}	% Term Factor	$V_{\text{OUT}} > V_{\text{RCH}}$, $V_{\text{IN}} = 5\text{V}$, $R_{\text{PRE-TERM}} = 2\text{k}$ to $10\text{k}\Omega$; $R_{\text{ISET}} = 750\Omega$ $K_{\text{TERM}} \times \%_{\text{FAST-CHG}}$, where $\%_{\text{FAST-CHG}}$ is 10 to 50%	182	200	216	$\Omega/\%$
		$V_{\text{OUT}} > V_{\text{RCH}}$, $V_{\text{IN}} = 5\text{V}$, $R_{\text{PRE-TERM}} = 1\text{k}$ to $2\text{k}\Omega$; $R_{\text{ISET}} = 750\Omega$ $K_{\text{TERM}} \times \%_{\text{ISET}}$, where $\%_{\text{ISET}}$ is 5 to 10%	174	199	224	
$I_{\text{PRE-TERM}}$	Current for programming the term. and prechg with resistor. $I_{\text{Term-Start}}$ is the initial PRE-TERM current.	$R_{\text{PRE-TERM}} = 2\text{k}$, $V_{\text{OUT}} = 4.15\text{V}$	71	75	81	μA
$\%_{\text{TERM}}$	Termination current formula			$R_{\text{TERM}}/K_{\text{TERM}}\%$		
$I_{\text{Term-Start}}$	Elevated PRE-TERM current for, $t_{\text{Term-Start}}$ during start of charge to prevent recharge of full battery,		80	85	92	μA
RECHARGE OR REFRESH – bq24040 / bq24045						
V_{RCH}	Recharge detection threshold – Normal Temp	$V_{\text{IN}} = 5\text{V}$, $V_{\text{TS}} = 0.5\text{V}$, $V_{\text{OUT}}: 4.25\text{V} \rightarrow V_{\text{RCH}}$	$V_{\text{O(REG)}}^{-0.120}$	$V_{\text{O(REG)}}^{-0.095}$	$V_{\text{O(REG)}}^{-0.070}$	V
	Recharge detection threshold – Hot Temp	$V_{\text{IN}} = 5\text{V}$, $V_{\text{TS}} = 0.2\text{V}$, $V_{\text{OUT}}: 4.15\text{V} \rightarrow V_{\text{RCH}}$	$V_{\text{O-HT(REG)}}^{-0.130}$	$V_{\text{O-HT(REG)}}^{-0.105}$	$V_{\text{O-HT(REG)}}^{-0.080}$	V
BATTERY DETECT ROUTINE – bq24040 / bq24045 (NOTE: In Hot mode $V_{\text{O(REG)}}$ becomes $V_{\text{O-HT(REG)}}$)						
$V_{\text{REG-BD}}$	V_{OUT} Reduced regulation during battery detect	$V_{\text{IN}} = 5\text{V}$, $V_{\text{TS}} = 0.5\text{V}$, Battery Absent	$V_{\text{O(REG)}}^{-0.450}$	$V_{\text{O(REG)}}^{-0.400}$	$V_{\text{O(REG)}}^{-0.350}$	V
$I_{\text{BD-SINK}}$	Sink current during $V_{\text{REG-BD}}$		7		10	mA
$V_{\text{BD-HI}}$	High battery detection threshold	$V_{\text{IN}} = 5\text{V}$, $V_{\text{TS}} = 0.5\text{V}$, Battery Absent	$V_{\text{O(REG)}}^{-0.150}$	$V_{\text{O(REG)}}^{-0.100}$	$V_{\text{O(REG)}}^{-0.050}$	V
$V_{\text{BD-LO}}$	Low battery detection threshold	$V_{\text{IN}} = 5\text{V}$, $V_{\text{TS}} = 0.5\text{V}$, Battery Absent	$V_{\text{REG-BD}}^{+0.50}$	$V_{\text{REG-BD}}^{+0.1}$	$V_{\text{REG-BD}}^{+0.15}$	V

Electrical Characteristics (continued)

 Over junction temperature range $0^{\circ}\text{C} \leq T_J \leq 125^{\circ}\text{C}$ and recommended supply voltage (unless otherwise noted)

PARAMETER		TEST CONDITIONS	MIN	TYP	MAX	UNIT
BATTERY-PACK NTC MONITOR; TS Terminal: bq24040 / bq24045: 10k NTC						
$I_{\text{NTC-10k}}$	NTC bias current	$V_{\text{TS}} = 0.3\text{V}$	48	50	52	μA
$I_{\text{NTC-DIS-10k}}$	10k NTC bias current when Charging is disabled.	$V_{\text{TS}} = 0\text{V}$	27	30	34	μA
$I_{\text{NTC-FLDBK-10k}}$	INTC is reduced prior to entering TTDM to keep cold thermistor from entering TTDM	V_{TS} : Set to 1.525V	4	5	6.5	μA
$V_{\text{TTDM(TS)}}$	Termination and timer disable mode Threshold – Enter	V_{TS} : 0.5V \rightarrow 1.7V; Timer Held in Reset	1550	1600	1650	mV
$V_{\text{HYS-TTDM(TS)}}$	Hysteresis exiting TTDM	V_{TS} : 1.7V \rightarrow 0.5V; Timer Enabled		100		mV
$V_{\text{CLAMP(TS)}}$	TS maximum voltage clamp	$V_{\text{TS}} = \text{Open (Float)}$	1800	1950	2000	mV
$V_{\text{TS}_I\text{-FLDBK}}$	TS voltage where INTC is reduce to keep thermistor from entering TTDM	INTC adjustment (90 to 10%; 45 to 6.6 μs) takes place near this spec threshold. V_{TS} : 1.425V \rightarrow 1.525V		1475		mV
C_{TS}	Optional Capacitance – ESD			0.22		μF
$V_{\text{TS-0}^{\circ}\text{C}}$	Low temperature CHG Pending	Low Temp Charging to Pending; V_{TS} : 1V \rightarrow 1.5V	1205	1230	1255	mV
$V_{\text{HYS-0}^{\circ}\text{C}}$	Hysteresis at 0°C	Charge pending to low temp charging; V_{TS} : 1.5V \rightarrow 1V		86		mV
$V_{\text{TS-10}^{\circ}\text{C}}$	Low temperature, half charge	Normal charging to low temp charging; V_{TS} : 0.5V \rightarrow 1V	765	790	815	mV
$V_{\text{HYS-10}^{\circ}\text{C}}$	Hysteresis at 10°C	Low temp charging to normal CHG; V_{TS} : 1V \rightarrow 0.5V		35		mV
$V_{\text{TS-45}^{\circ}\text{C}}$	High temperature at 4.1V	Normal charging to high temp CHG; V_{TS} : 0.5V \rightarrow 0.2V	263	278	293	mV
$V_{\text{HYS-45}^{\circ}\text{C}}$	Hysteresis at 45°C	High temp charging to normal CHG; V_{TS} : 0.2V \rightarrow 0.5V		10.7		mV
$V_{\text{TS-60}^{\circ}\text{C}}$	High temperature Disable	High temp charge to pending; V_{TS} : 0.2V \rightarrow 0.1V	170	178	186	mV
$V_{\text{HYS-60}^{\circ}\text{C}}$	Hysteresis at 60°C	Charge pending to high temp CHG; V_{TS} : 0.1V \rightarrow 0.2V		11.5		mV
$V_{\text{TS-EN-10k}}$	Charge Enable Threshold, (10k NTC)	V_{TS} : 0V \rightarrow 0.175V;	80	88	96	mV
$V_{\text{TS-DIS-HYS-10k}}$	HYS below $V_{\text{TS-EN-10k}}$ to Disable, (10k NTC)	V_{TS} : 0.125V \rightarrow 0V;		12		mV
THERMAL REGULATION						
$T_{\text{J(REG)}}$	Temperature regulation limit			125		$^{\circ}\text{C}$
$T_{\text{J(OFF)}}$	Thermal shutdown temperature			155		$^{\circ}\text{C}$
$T_{\text{J(OFF-HYS)}}$	Thermal shutdown hysteresis			20		$^{\circ}\text{C}$
BAT_EN , bq24041						
$I_{\text{BAT_EN}}$	Current Sourced out of terminal	$V_{\text{BAT_EN}} < 1.4\text{V}$	2.3	5	9	μA
V_{IL}	Logic LOW enables charger		0		0.4	V
V_{IH}	Logic HIGH disables charger		1.1		6	V
V_{CLAMP}	Floating Clamp Voltage	Floating BAT_EN terminal	1.4	1.6	1.8	V
LOGIC LEVELS ON ISET2						
V_{IL}	Logic LOW input voltage	Sink 8 μA			0.4	V
V_{IH}	Logic HIGH input voltage	Source 8 μA	1.4			V
I_{IL}	Sink current required for LO	$V_{\text{ISET2}} = 0.4\text{V}$	2		9	μA
I_{IH}	Source current required for HI	$V_{\text{ISET2}} = 1.4\text{V}$	1.1		8	μA
V_{FLT}	ISET2 Float Voltage		575	900	1225	mV
AUTO START, ASI AND ASO TERMINALS, bq24041						
V_{ASIL}	Has 200k Internal Pull-down				0.4	V
V_{ASIH}			1.3			V
V_{ASOL}	Auto Start Output Sinks 1mA				0.4	V
V_{ASOH}	Auto Start Input Sources 1mA		$V_{\text{OUT}} - 0.4$			V
LOGIC LEVELS ON CHG AND PG						
V_{OL}	Output LOW voltage	$I_{\text{SINK}} = 5\text{mA}$			0.4	V
I_{LEAK}	Leakage current into IC	$V_{\text{CHG}} = 5\text{V}$, $V_{\text{PG}} = 5\text{V}$			1	μA

7.6 Timing Requirements

			MIN	TYP	MAX	UNIT
INPUT						
$t_{DGL(PG_PWR)}$	Deglitch time on exiting sleep.	Time measured from V_{IN} : 0V → 5V 1 μ s rise-time to $\overline{PG} = \text{low}$, $V_{OUT} = 3.6V$		45		μ s
$t_{DGL(PG_NO_PWR)}$	Deglitch time on V_{HYS_INDT} power down. Same as entering sleep.	Time measured from V_{IN} : 5V → 3.2V 1 μ s fall-time to $\overline{PG} = \text{OC}$, $V_{OUT} = 3.6V$		29		ms
$t_{DGL(OVP_SET)}$	Input over-voltage blanking time	V_{IN} : 5V → 12V		113		μ s
$t_{DGL(OVP_REC)}$	Deglitch time exiting OVP	Time measured from V_{IN} : 12V → 5V 1 μ s fall-time to $\overline{PG} = \text{LO}$		30		μ s
ISET SHORT CIRCUIT TEST						
t_{DGL_SHORT}	Deglitch time transition from ISET short to I_{OUT} disable	Clear fault by disconnecting IN or cycling (high / low) TS/BAT_EN		1		ms
PRECHARGE – SET BY PRETERM PIN: bq24040 / bq24045; Internally Set: bq24041						
$t_{DGL1(LOWV)}$	Deglitch time on pre-charge to fast-charge transition			70		μ s
$t_{DGL2(LOWV)}$	Deglitch time on fast-charge to pre-charge transition			32		ms
TERMINATION – SET BY PRE-TERM PIN: bq24040 / bq24045						
$t_{DGL(TERM)}$	Deglitch time, termination detected			29		ms
$t_{Term-Start}$	Elevated termination threshold initially active for $t_{Term-Start}$			1.25		min
RECHARGE OR REFRESH – bq24040 / bq24045						
$t_{DGL1(RCH)}$	Deglitch time, recharge threshold detected	$V_{IN} = 5V$, $V_{TS} = 0.5V$, $V_{OUT} = 4.25V \rightarrow 3.5V$ in 1 μ s; $t_{DGL(RCH)}$ is time to ISET ramp		29		ms
$t_{DGL2(RCH)}$	Deglitch time, recharge threshold detected in OUT-Detect Mode	$V_{IN} = 5V$, $V_{TS} = 0.5V$, $V_{OUT} = 3.5V$ inserted; $t_{DGL(RCH)}$ is time to ISET ramp		3.6		ms
BATTERY DETECT ROUTINE – bq24040 / bq24045 (NOTE: In Hot mode $V_{O(REG)}$ becomes $V_{O_HT(REG)}$)						
$t_{DGL(HI/LOW_REG)}$	Regulation time at V_{REG} or V_{REG-BD}			25		ms
BATTERY CHARGING TIMERS AND FAULT TIMERS: bq24040 and bq24045 only						
t_{PRECHG}	Pre-charge safety timer value	Restarts when entering Pre-charge; Always enabled when in pre-charge.	1700	1940	2250	s
t_{MAXCH}	Charge safety timer value	Clears fault or resets at UVLO, TS/BAT_EN disable, OUT Short, exiting LOWV and Refresh	34000	38800	45000	s
BATTERY-PACK NTC MONITOR; TS Terminal: bq24040 / bq24045: 10k NTC						
$t_{DGL(TTDM)}$	Deglitch exit TTDM between states			57		ms
	Deglitch enter TTDM between states			8		μ s
$t_{DGL(TS_10C)}$	Deglitch for TS thresholds: 10C.	Normal to Cold Operation; V_{TS} : 0.6V → 1V		50		ms
		Cold to Normal Operation; V_{TS} : 1V → 0.6V		12		ms
$t_{DGL(TS)}$	Deglitch for TS thresholds: 0/45/60C.	Battery charging		30		ms

7.7 Typical Operational Characteristics (Protection Circuits Waveforms)

SETUP: bq24040 typical applications schematic; $V_{IN} = 5V$, $V_{BAT} = 3.6V$ (unless otherwise indicated)

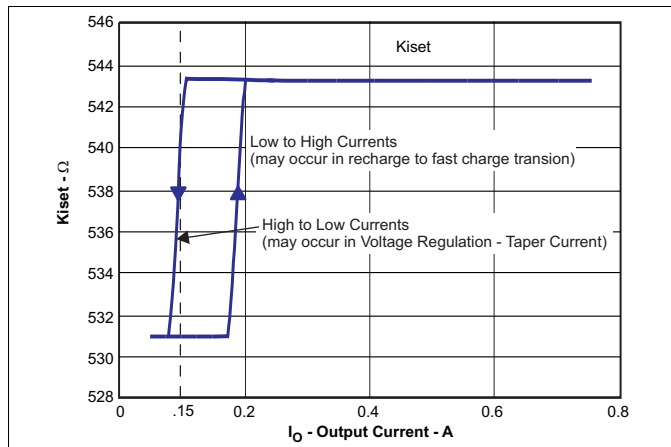

Figure 1. Kiset for Low and High Currents

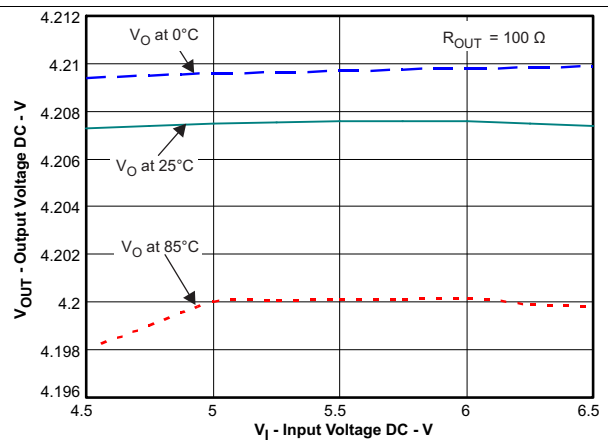

Figure 2. Line Regulation

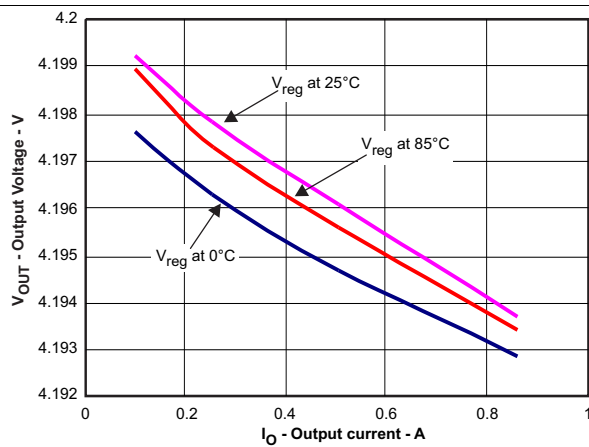

Figure 3. Load Regulation Over Temperature

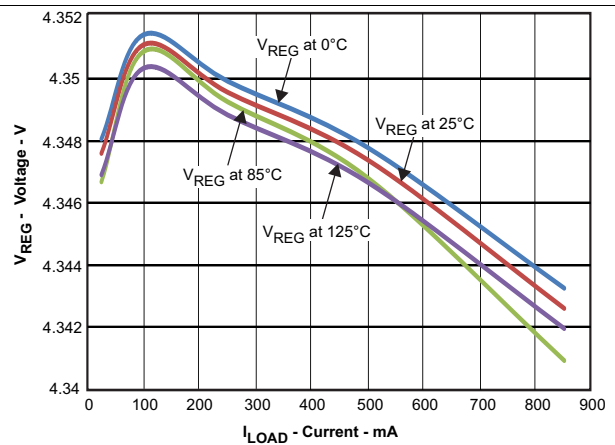

Figure 4. Load Regulation

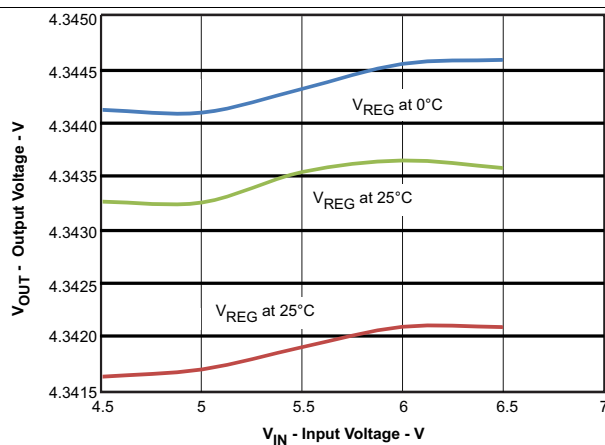

Figure 5. Line Regulation

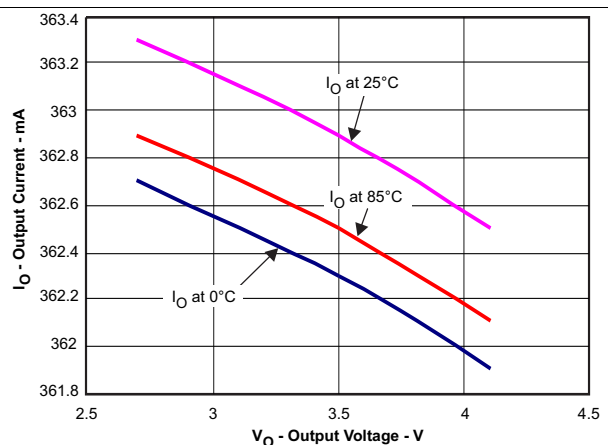

Figure 6. Current Regulation Over Temperature

8 Detailed Description

8.1 Overview

The bq2404x is a highly integrate family of 2x2 single cell Li-Ion and Li-Pol chargers. The charger can be used to charge a battery, power a system or both. The charger has three phases of charging: Pre-charge to recover a fully discharged battery, fast-charge constant current to supply the buck charge safely and voltage regulation to safely reach full capacity. The charger is very flexible, allowing programming of the fast-charge current and Pre-charge/Termination Current (bq24040/5 only). This charger is designed to work with a USB connection or Adaptor (DC out). The charger also checks to see if a battery is present.

The charger also comes with a full set of safety features: JEITA Temperature Standard (bq24040/5 only), Over-Voltage Protection, DPM-IN, Safety Timers, and ISET short protection. All of these features and more are described in detail below.

The charger is designed for a single power path from the input to the output to charge a single cell Li-Ion or Li-Pol battery pack. Upon application of a 5VDC power source the ISET and OUT short checks are performed to assure a proper charge cycle.

If the battery voltage is below the LOWV threshold, the battery is considered discharged and a preconditioning cycle begins. The amount of precharge current can be programmed using the PRE-TERM terminal which programs a percent of fast charge current (10 to 100%) as the precharge current. This feature is useful when the system load is connected across the battery “stealing” the battery current. The precharge current can be set higher to account for the system loading while allowing the battery to be properly conditioned. The PRE-TERM terminal is a dual function terminal which sets the precharge current level and the termination threshold level. The termination “current threshold” is always half of the precharge programmed current level.

Once the battery voltage has charged to the VLOWV threshold, fast charge is initiated and the fast charge current is applied. The fast charge constant current is programmed using the ISET terminal. The constant current provides the bulk of the charge. Power dissipation in the IC is greatest in fast charge with a lower battery voltage. If the IC reaches 125°C the IC enters thermal regulation, slows the timer clock by half and reduce the charge current as needed to keep the temperature from rising any further. [Figure 8](#) shows the charging profile with thermal regulation. Typically under normal operating conditions, the IC’s junction temperature is less than 125°C and thermal regulation is not entered.

Once the cell has charged to the regulation voltage the voltage loop takes control and holds the battery at the regulation voltage until the current tapers to the termination threshold. The termination can be disabled if desired. The CHG terminal is low (LED on) during the first charge cycle only and turns off once the termination threshold is reached, regardless if termination, for charge current, is enabled or disabled.

Further details are mentioned in the Operating Modes section.

8.2 Functional Block Diagram

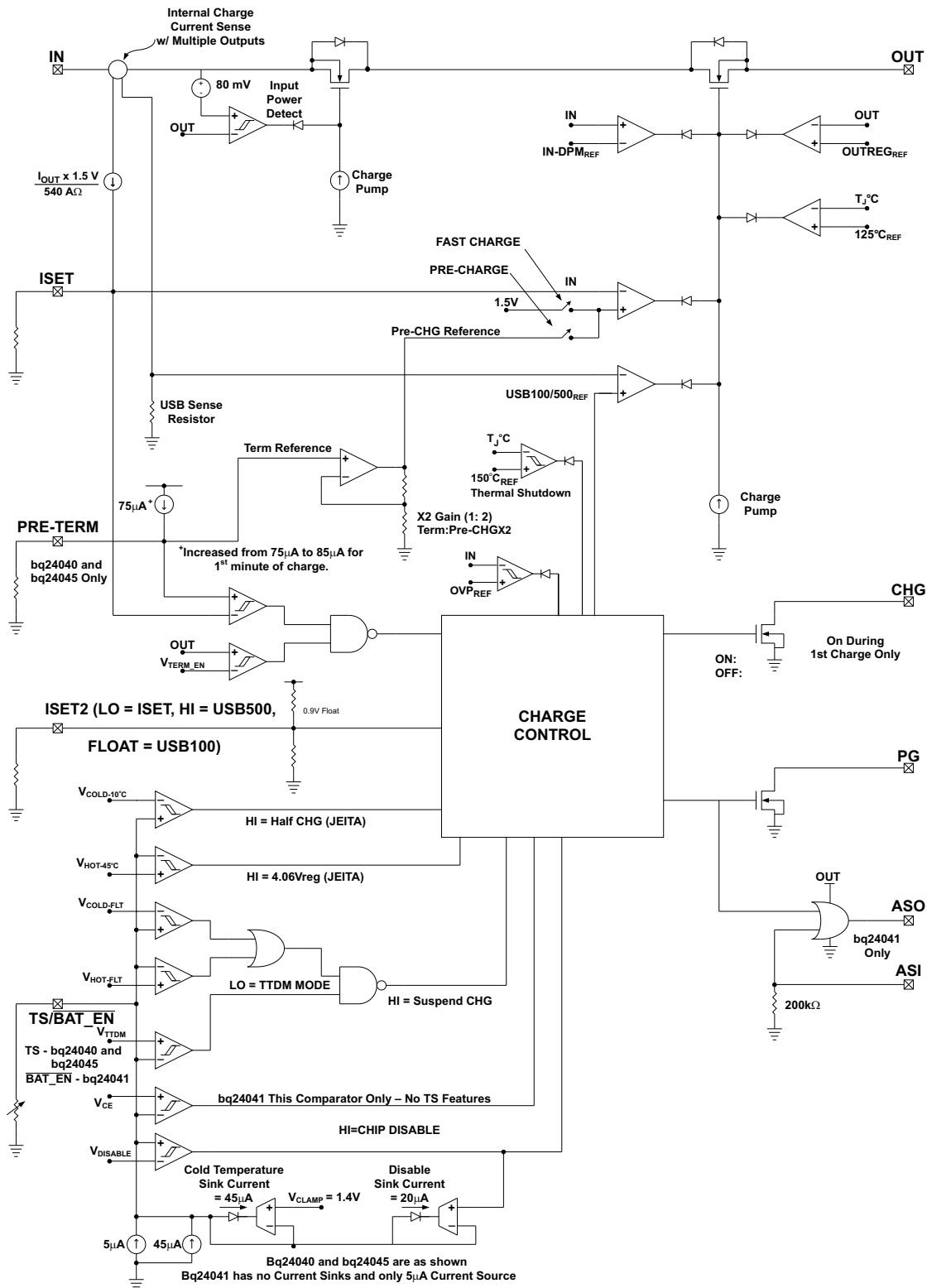

Functional Block Diagram (continued)

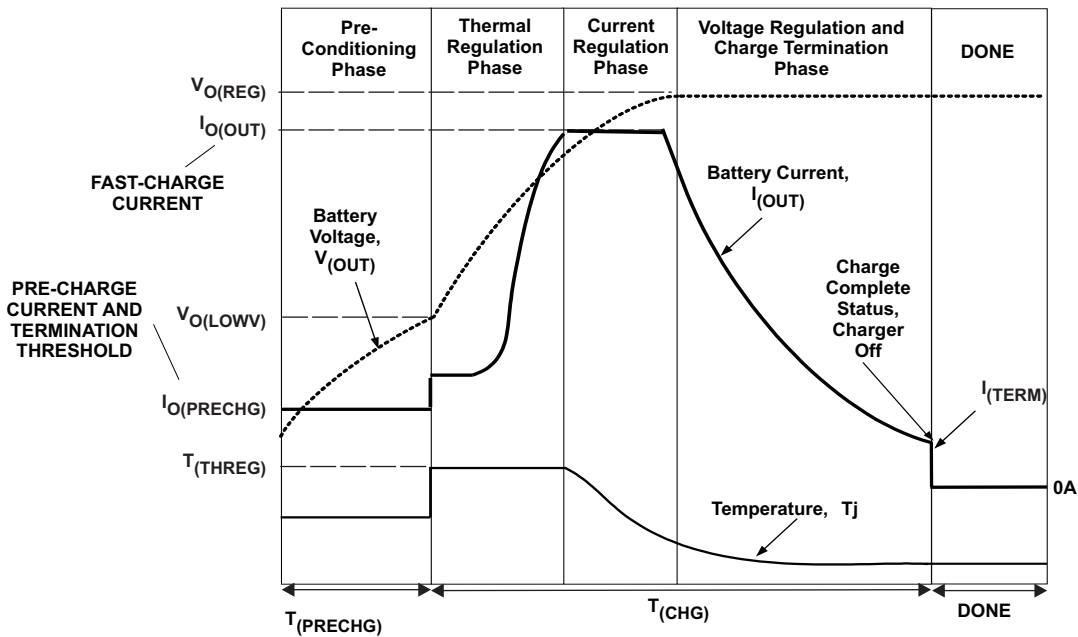

Figure 8. Charging Profile With Thermal Regulation

8.3 Feature Description

8.3.1 Power-Down or Undervoltage Lockout (UVLO)

The bq2404x family is in power down mode if the IN terminal voltage is less than UVLO. The part is considered “dead” and all the terminals are high impedance. Once the IN voltage rises above the UVLO threshold the IC will enter Sleep Mode or Active mode depending on the OUT terminal (battery) voltage.

8.3.2 Power-up

The IC is alive after the IN voltage ramps above UVLO (see sleep mode), resets all logic and timers, and starts to perform many of the continuous monitoring routines. Typically the input voltage quickly rises through the UVLO and sleep states where the IC declares power good, starts the qualification charge at 100mA, sets the input current limit threshold base on the ISET2 terminal, starts the safety timer and enables the CHG terminal. See Figure 9.

8.3.3 Sleep Mode

If the IN terminal voltage is between $V_{OUT} + V_{DT}$ and UVLO, the charge current is disabled, the safety timer counting stops (not reset) and the PG and CHG terminals are high impedance. As the input voltage rises and the charger exits sleep mode, the PG terminal goes low, the safety timer continues to count, charge is enabled and the CHG terminal returns to its previous state. See Figure 10.

8.3.4 New Charge Cycle

A new charge cycle is started when a good power source is applied, performing a chip disable/enable (TS terminal/BAT_EN), exiting Termination and Timer Disable Mode (TTDM), detecting a battery insertion or the OUT voltage dropterminalg below the VRCH threshold. The CHG terminal is active low only during the first charge cycle, therefore exiting TTDM or a dropterminalg below VRCH will not turn on the CHG terminal FET, if the CHG terminal is already high impedance.

Feature Description (continued)

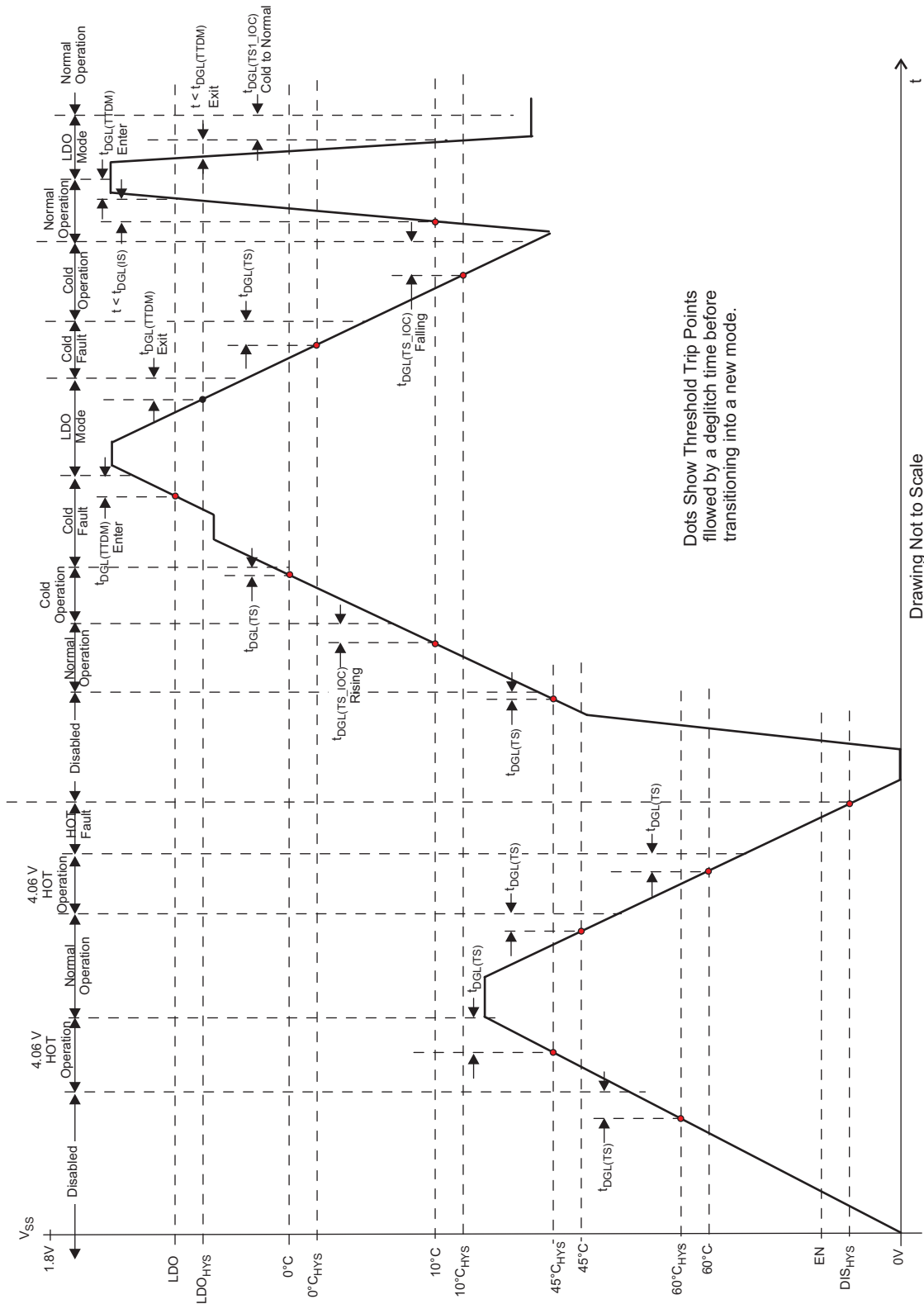

Figure 9. TS Battery Temperature Bias Threshold and Deglitch Timers

Feature Description (continued)

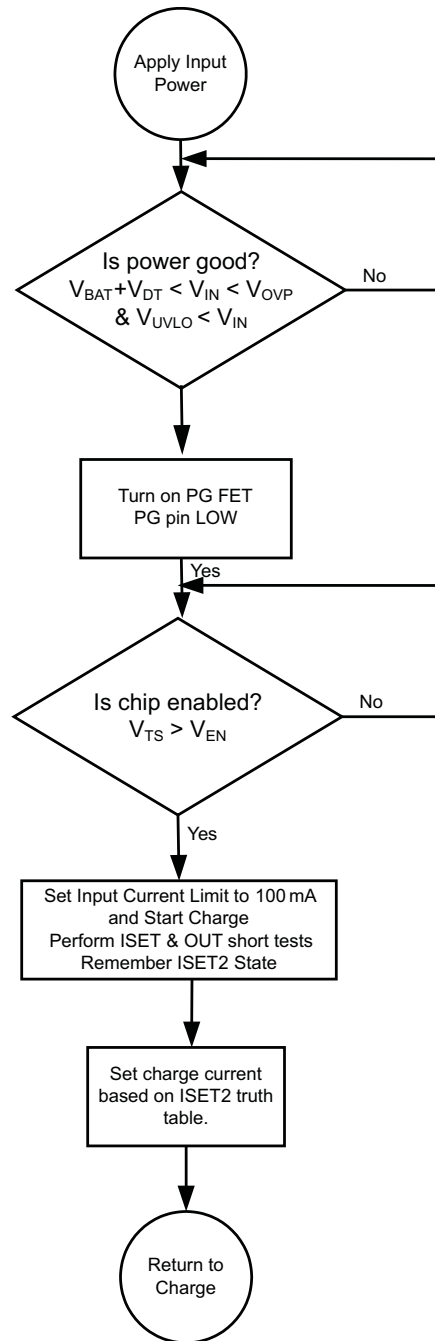

Figure 10. bq2404x Power-Up Flow Diagram

8.3.5 Overvoltage-Protection (OVP) – Continuously Monitored

If the input source applies an overvoltage, the pass FET, if previously on, turns off after a deglitch, $t_{BLK(OVP)}$. The timer ends and the **CHG** and **PG** terminal goes to a high impedance state. Once the overvoltage returns to a normal voltage, the **PG** terminal goes low, timer continues, charge continues and the **CHG** terminal goes low after a 25ms deglitch. **PG** terminal is optional on some packages

Feature Description (continued)

8.3.6 Power Good Indication ($\overline{\text{PG}}$)

After application of a 5V source, the input voltage rises above the UVLO and sleep thresholds ($V_{\text{IN}} > V_{\text{BAT}} + V_{\text{DT}}$), but is less than OVP ($V_{\text{IN}} < V_{\text{OVP}}$), then the PG FET turns on and provides a low impedance path to ground. See [Figure 20](#), [Figure 21](#), and [Figure 33](#).

8.3.7 $\overline{\text{CHG}}$ Terminal Indication

The charge terminal has an internal open drain FET which is on (pulls down to V_{SS}) during the first charge only (independent of TTDM) and is turned off once the battery reaches voltage regulation and the charge current tapers to the termination threshold set by the PRE-TERM resistor. The bq24041 does not terminate charge, however, the $\overline{\text{CHG}}$ terminal will turn off once the battery current reaches 10% of the programmed charge current.

The charge terminal is high impedance in sleep mode and OVP (if $\overline{\text{PG}}$ is high impedance) and return to its previous state once the condition is removed.

Cycling input power, pulling the TS terminal low and releasing or entering pre-charge mode causes the $\overline{\text{CHG}}$ terminal to go reset (go low if power is good and a discharged battery is attached) and is considered the start of a first charge.

8.4 Device Functional Modes

8.4.1 $\overline{\text{CHG}}$ and $\overline{\text{PG}}$ LED Pull-up Source

For host monitoring, a pull-up resistor is used between the "STATUS" terminal and the V_{CC} of the host and for a visual indication a resistor in series with an LED is connected between the "STATUS" terminal and a power source. If the CHG or PG source is capable of exceeding 7V, a 6.2V zener should be used to clamp the voltage. If the source is the OUT terminal, note that as the battery changes voltage, and the brightness of the LEDs vary.

Charging State	$\overline{\text{CHG}}$ FET/LED
1st Charge after VIN applied	ON
Refresh Charge	OFF
OVP	
SLEEP	
TEMP FAULT	ON for 1st Charge

V_{IN} Power Good State	$\overline{\text{PG}}$ FET/LED
UVLO	OFF
SLEEP Mode	
OVP Mode	
Normal Input ($V_{\text{OUT}} + V_{\text{DT}} < V_{\text{IN}} < V_{\text{OUP}}$)	ON
PG is independent of chip disable	

8.4.2 Auto Start-up (bq24041)

The auto start-up feature is an OR gate with two inputs; an internal power good signal (logic 1 when $V_{\text{IN}} > V_{\text{BAT}} + V_{\text{IN-DT}}$) and an external input from ASI terminal (internal 100k pull-down). The ASO terminal outputs a signal that can be used as a system boot signal. The OR gate is powered by the OUT terminal and the OUT terminal must be powered by an external source (battery or P/S) or via the IN terminal for the ASO terminal to deliver a logic High. The ASI and/or the internal power good signal have to be logic high for the ASO to be logic high. The ASI/ASO, OUT and PG signals are used in production testing to test the system without a battery.

8.4.3 IN-DPM (V_{IN-DPM} or IN-DPM)

The IN-DPM feature is used to detect an input source voltage that is folding back (voltage dropterminalg), reaching its current limit due to excessive load. When the input voltage drops to the V_{IN-DPM} threshold the internal pass FET starts to reduce the current until there is no further drop in voltage at the input. This would prevent a source with voltage less than V_{IN-DPM} to power the out terminal. This works well with current limited adaptors and USB ports as long as the nominal voltage is above 4.3V and 4.4V respectively. This is an added safety feature that helps protect the source from excessive loads.

8.4.4 OUT

The Charger's OUT terminal provides current to the battery and to the system, if present. This IC can be used to charge the battery plus power the system, charge just the battery or just power the system (TTDM) assuming the loads do not exceed the available current. The OUT terminal is a current limited source and is inherently protected against shorts. If the system load ever exceeds the output programmed current threshold, the output will be discharged unless there is sufficient capacitance or a charged battery present to supplement the excessive load.

8.4.5 ISET

An external resistor is used to Program the Output Current (50 to 1000mA) and can be used as a current monitor.

$$R_{ISET} = K_{ISET} \div I_{OUT} \tag{1}$$

Where:

- I_{OUT} is the desired fast charge current;
- K_{ISET} is a gain factor found in the electrical specification

For greater accuracy at lower currents, part of the sense FET is disabled to give better resolution. Figure 1 shows the transition from low current to higher current. Going from higher currents to low currents, there is hysteresis and the transition occurs around 0.15A.

The ISET resistor is short protected and will detect a resistance lower than #340Ω. The detection requires at least 80mA of output current. If a "short" is detected, then the IC will latch off and can only be reset by cycling the power. The OUT current is internally clamped to a maximum current between 1.05A and 1.4A and is independent of the ISET short detection circuitry, as shown in Figure 12. Also, see Figure 28 and Figure 29.

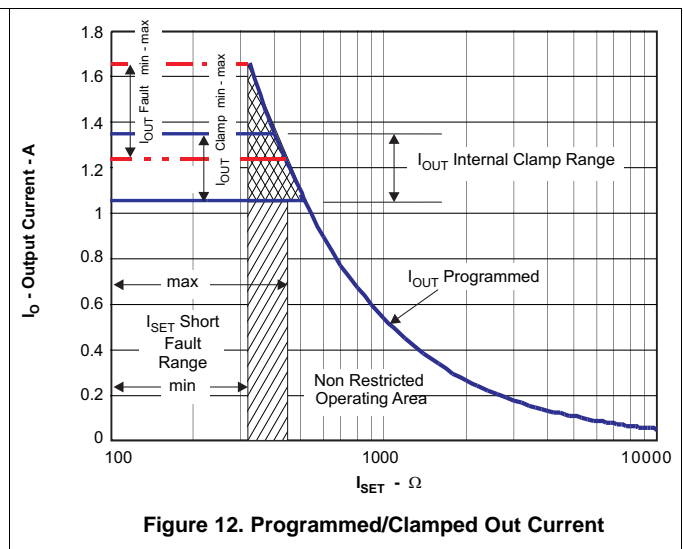
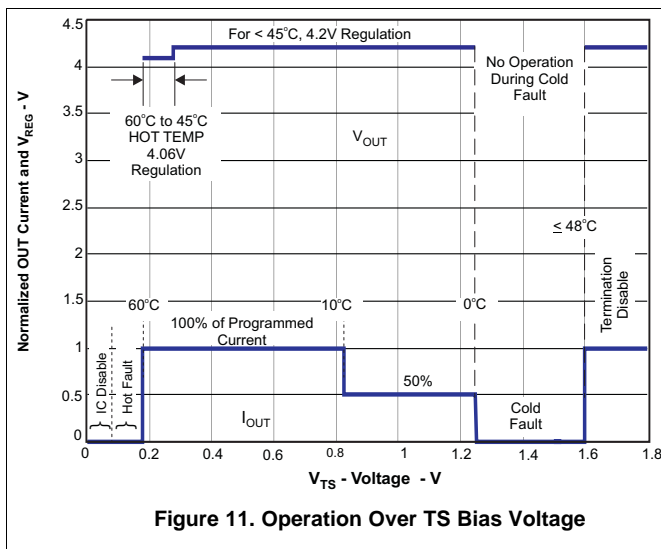

8.4.6 PRE_TERM – Pre-Charge and Termination Programmable Threshold, bq24040/5

Pre-Term is used to program both the pre-charge current and the termination current threshold. The pre-charge current level is a factor of two higher than the termination current level. The termination can be set between 5 and 50% of the programmed output current level set by ISET. If left floating the termination and pre-charge are set internally at 10/20% respectively. The pre-charge-to-fast-charge, V_{lowv} threshold is set to 2.5V.

$$R_{PRE-TERM} = \%Term \times K_{TERM} = \%Pre-CHG \times K_{PRE-CHG} \quad (2)$$

Where:

- %Term is the percent of fast charge current where termination occurs;
- %Pre-CHG is the percent of fast charge current that is desired during precharge;
- K_{TERM} and $K_{PRE-CHG}$ are gain factors found in the electrical specifications.

8.4.7 ISET2

Is a 3-state input and programs the Input Current Limit/Regulation Threshold. A low will program a regulated fast charge current via the ISET resistor and is the maximum allowed input/output current for any ISET2 setting, Float will program a 100mA Current limit and High will program a 500mA Current limit.

Below are two configurations for driving the 3-state ISET2 terminal:

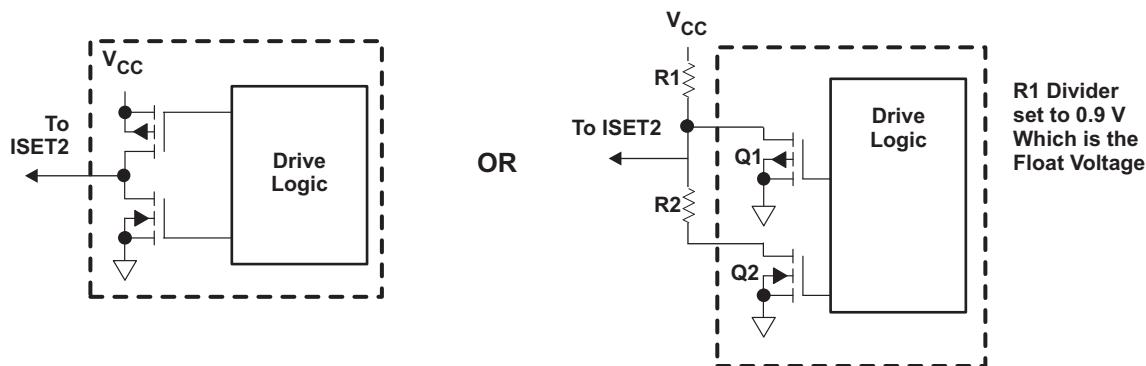

Figure 13. 3-state ISET2 Terminal Circuits

8.4.8 TS (bq24040/5)

The TS function for the bq24040/5 is designed to follow the new JEITA temperature standard for Li-Ion and Li-Pol batteries. There are now four thresholds, 60°C, 45°C, 10°C, and 0°C. Normal operation occurs between 10°C and 45°C. If between 0°C and 10°C the charge current level is cut in half and if between 45°C and 60°C the regulation voltage is reduced to 4.1Vmax, see [Figure 11](#).

The TS feature is implemented using an internal 50µA current source to bias the thermistor (designed for use with a 10k NTC $\beta = 3370$ (SEMITEC 103AT-2 or Mitsubishi TH05-3H103F) connected from the TS terminal to V_{SS} . If this feature is not needed, a fixed 10kΩ can be placed between TS and V_{SS} to allow normal operation. This may be done if the host is monitoring the thermistor and then the host would determine when to pull the TS terminal low to disable charge.

The TS terminal has two additional features, when the TS terminal is pulled low or floated/driven high. A low disables charge (similar to a high on the BAT_EN feature) and a high puts the charger in TTDM.

Above 60°C or below 0°C the charge is disabled. Once the thermistor reaches $\approx -10^\circ\text{C}$ the TS current folds back to keep a cold thermistor (between -10°C and -50°C) from placing the IC in the TTDM mode. If the TS terminal is pulled low into disable mode, the current is reduce to $\approx 30\mu\text{A}$, see [Figure 9](#). Since the I_{TS} current is fixed along with the temperature thresholds, it is not possible to use thermistor values other than the 10k NTC (at 25°C).

8.4.9 Termination and Timer Disable Mode (TTDM) - TS Terminal High

The battery charger is in TTDM when the TS terminal goes high from removing the thermistor (removing battery pack/floating the TS terminal) or by pulling the TS terminal up to the TTDM threshold.

When entering TTDM, the 10 hour safety timer is held in reset and termination is disabled. A battery detect routine is run to see if the battery was removed or not. If the battery was removed then the $\overline{\text{CHG}}$ terminal will go to its high impedance state if not already there. If a battery is detected the $\overline{\text{CHG}}$ terminal does not change states until the current tapers to the termination threshold, where the $\overline{\text{CHG}}$ terminal goes to its high impedance state if not already there (the regulated output will remain on).

The charging profile does not change (still has pre-charge, fast-charge constant current and constant voltage modes). This implies the battery is still charged safely and the current is allowed to taper to zero.

When coming out of TTDM, the battery detect routine is run and if a battery is detected, then a new charge cycle begins and the $\overline{\text{CHG}}$ LED turns on.

If TTDM is not desired upon removing the battery with the thermistor, one can add a 237k resistor between TS and V_{SS} to disable TTDM. This keeps the current source from driving the TS terminal into TTDM. This creates $\pm 0.1^\circ\text{C}$ error at hot and a $\pm 3^\circ\text{C}$ error at cold.

8.4.10 Timers, bq24040 and bq24045 only

The pre-charge timer is set to 30 minutes. The pre-charge current, can be programmed to off-set any system load, making sure that the 30 minutes is adequate. The bq24041 does not have a safety timer.

The fast charge timer is fixed at 10 hours and can be increased real time by going into thermal regulation, IN-DPM or if in USB current limit. The timer clock slows by a factor of 2, resulting in a clock that counts half as fast when in these modes. If either the 30 minute or ten hour timer times out, the charging is terminated and the $\overline{\text{CHG}}$ terminal goes high impedance if not already in that state. The timer is reset by disabling the IC, cycling power or going into and out of TTDM.

8.4.11 Termination

Once the OUT terminal goes above V_{RCH} , (reaches voltage regulation) and the current tapers down to the termination threshold, the $\overline{\text{CHG}}$ terminal goes high impedance and a battery detect routine is run to determine if the battery was removed or the battery is full. If the battery is present, the charge current will terminate. If the battery was removed along with the thermistor, then the TS terminal is driven high and the charge enters TTDM. If the battery was removed and the TS terminal is held in the active region, then the battery detect routine will continue until a battery is inserted.

8.4.12 Battery Detect Routine

The battery detect routine should check for a missing battery while keeping the OUT terminal at a useable voltage. Whenever the battery is missing the $\overline{\text{CHG}}$ terminal should be high impedance.

The battery detect routine is run when entering and exiting TTDM to verify if battery is present, or run all the time if battery is missing and not in TTDM. On power-up, if battery voltage is greater than V_{RCH} threshold, a battery detect routine is run to determine if a battery is present.

The battery detect routine is disabled while the IC is in TTDM, or has a TS fault. See [Figure 14](#) for the Battery Detect Flow Diagram.

8.4.13 Refresh Threshold

After termination, if the OUT terminal voltage drops to V_{RCH} (100mV below regulation) then a new charge is initiated, but the $\overline{\text{CHG}}$ terminal remains at a high impedance (off).

8.4.14 Starting a Charge on a Full Battery

The termination threshold is raised by $\pm 14\%$, for the first minute of a charge cycle so if a full battery is removed and reinserted or a new charge cycle is initiated, that the new charge terminates (less than 1 minute). Batteries that have relaxed many hours may take several minutes to taper to the termination threshold and terminate charge.

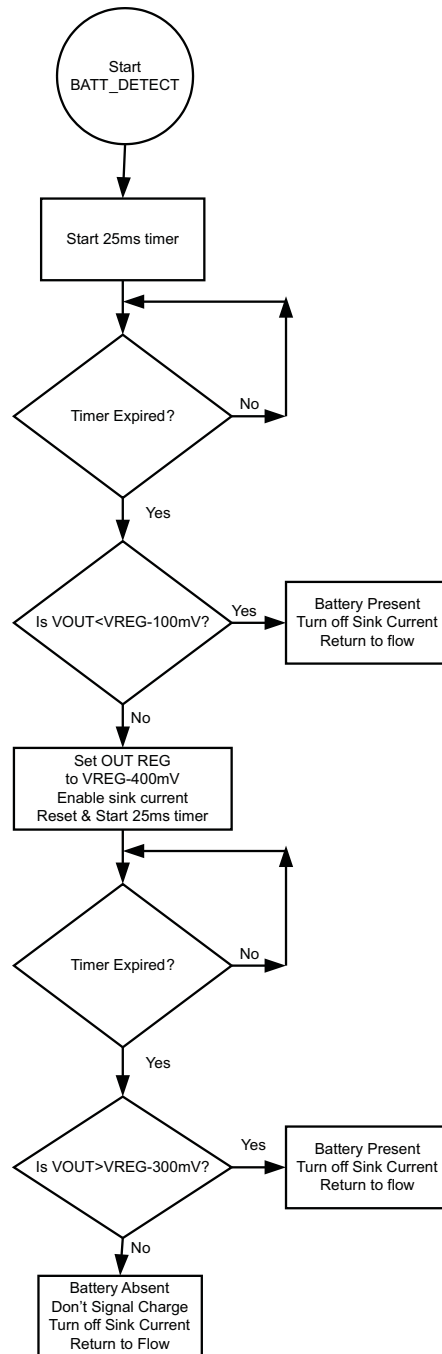

Figure 14. Battery Detect Routine (bq24040)

9 Application and Implementation

NOTE

Information in the following applications sections is not part of the TI component specification, and TI does not warrant its accuracy or completeness. TI's customers are responsible for determining suitability of components for their purposes. Customers should validate and test their design implementation to confirm system functionality.

9.1 Application Information

The bq2404x series of devices are highly integrated Li-Ion and Li-Pol linear chargers devices targeted at space-limited portable applications. The devices operate from either a USB port or AC adaptor. The high input voltage range with input overvoltage protection supports low-cost unregulated adapters. These devices have a single power output that charges the battery. A system load can be placed in parallel with the battery as long as the average system load does not keep the battery from charging fully during the 10 hour safety timer.

9.2 Typical Applications

9.2.1 Typical Application: bq24040 and bq24045

$I_{OUT_FAST_CHG} = 540\text{mA}$; $I_{OUT_PRE_CHG} = 108\text{mA}$; $I_{OUT_TERM} = 54\text{mA}$

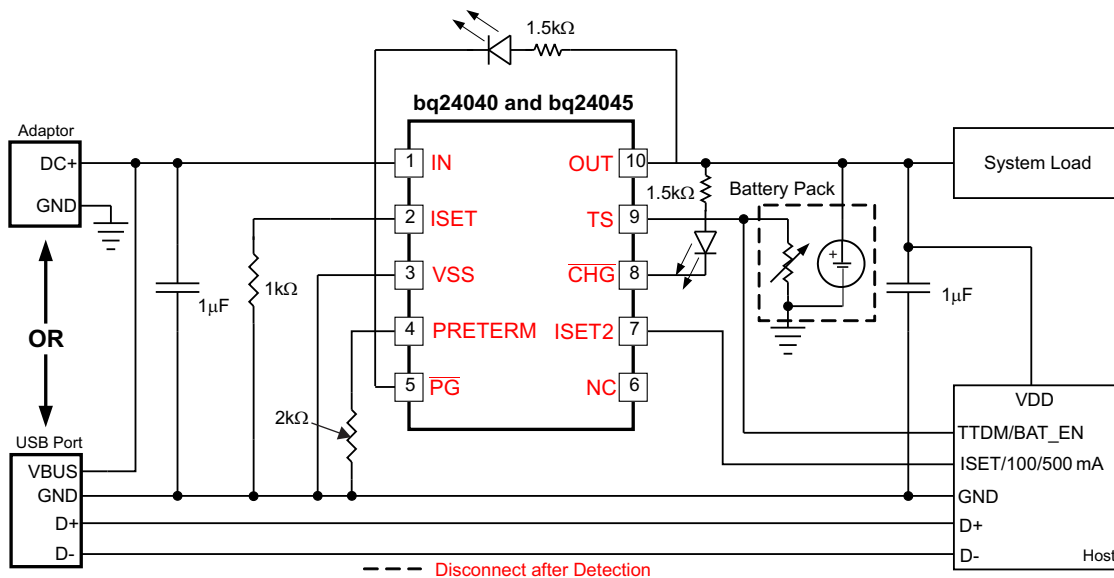

Figure 15. Typical Application Circuit: bq24040 and bq24045

9.2.1.1 Design Requirements

- Supply voltage = 5 V
- Fast charge current: $I_{OUT_FC} = 540\text{ mA}$; ISET-terminal 2
- Termination Current Threshold: $\%I_{OUT_FC} = 10\%$ of Fast Charge or $\sim 54\text{mA}$
- Pre-Charge Current by default is twice the termination Current or $\sim 108\text{mA}$
- TS – Battery Temperature Sense = 10k NTC (103AT)

Typical Applications (continued)

9.2.1.2 Detailed Design Procedures

9.2.1.2.1 Calculations

9.2.1.2.1.1 Program the Fast Charge Current, ISET:

$$R_{ISET} = [K_{(ISET)} / I_{(OUT)}] \quad (3)$$

From the [Electrical Characteristics](#) table:

- $K_{(SET)} = 540A\Omega$
- $R_{ISET} = [540A\Omega / 0.54A] = 1.0 \text{ k}\Omega$

Selecting the closest standard value, use a 1.0 k Ω resistor between ISET (terminal 16) and Vss.

9.2.1.2.1.2 Program the Termination Current Threshold, ITERM:

$$R_{PRE-TERM} = K_{(TERM)} \times \%I_{OUT-FC} \quad (4)$$

$$R_{PRE-TERM} = 200\Omega/\% \times 10\% = 2\text{k}\Omega \quad (5)$$

Selecting the closest standard value, use a 2 k Ω resistor between ITERM (terminal 15) and Vss.

One can arrive at the same value by using 20% for a pre-charge value (factor of 2 difference).

$$R_{PRE-TERM} = K_{(PRE-CHG)} \times \%I_{OUT-FC} \quad (6)$$

$$R_{PRE-TERM} = 100\Omega/\% \times 20\% = 2\text{k}\Omega \quad (7)$$

9.2.1.2.1.3 TS Function (bq24040)

Use a 10k NTC thermistor in the battery pack (103AT).

To Disable the temp sense function, use a fixed 10k resistor between the TS (terminal 1) and Vss.

9.2.1.2.1.4 \overline{CHG} and PG

LED Status: connect a 1.5k resistor in series with a LED between the OUT terminal and the \overline{CHG} terminal.

Connect a 1.5k resistor in series with a LED between the OUT terminal and the and PG terminal.

Processor Monitoring: Connect a pull-up resistor between the processor's power rail and the \overline{CHG} terminal.

Connect a pull-up resistor between the processor's power rail and the PG terminal.

9.2.1.2.2 Selecting In and Out Terminal Capacitors

In most applications, all that is needed is a high-frequency decoupling capacitor (ceramic) on the power terminal, input and output terminals. Using the values shown on the application diagram, is recommended. After evaluation of these voltage signals with real system operational conditions, one can determine if capacitance values can be adjusted toward the minimum recommended values (DC load application) or higher values for fast high amplitude pulsed load applications. Note if designed for high input voltage sources (bad adaptors or wrong adaptors), the capacitor needs to be rated appropriately. Ceramic capacitors are tested to 2x their rated values so a 16V capacitor may be adequate for a 30V transient (verify tested rating with capacitor manufacturer).

9.2.1.2.3 Thermal Package

The bq2404x family is packaged in a thermally enhanced MLP package. The package includes a thermal pad to provide an effective thermal contact between the IC and the printed circuit board (PCB). The power pad should be directly connected to the VSS terminal. Full PCB design guidelines for this package are provided in the application note entitled: *QFN/SON PCB Attachment* Application Note ([SLUA271](#)). The most common measure of package thermal performance is thermal impedance (θ_{JA}) measured (or modeled) from the chip junction to the air surrounding the package surface (ambient). The mathematical expression for θ_{JA} is:

$$\theta_{JA} = (T_J - T) / P \quad (8)$$

Where:

- T_J = chip junction temperature
- T = ambient temperature
- P = device power dissipation

Typical Applications (continued)

Factors that can influence the measurement and calculation of θ_{JA} include:

1. Whether or not the device is board mounted
2. Trace size, composition, thickness, and geometry
3. Orientation of the device (horizontal or vertical)
4. Volume of the ambient air surrounding the device under test and airflow
5. Whether other surfaces are in close proximity to the device being tested

Due to the charge profile of Li-Ion and Li-Pol batteries the maximum power dissipation is typically seen at the beginning of the charge cycle when the battery voltage is at its lowest. Typically after fast charge begins the pack voltage increases to $\approx 3.4V$ within the first 2 minutes. The thermal time constant of the assembly typically takes a few minutes to heat up so when doing maximum power dissipation calculations, 3.4V is a good minimum voltage to use. This is verified, with the system and a fully discharged battery, by plotting temperature on the bottom of the PCB under the IC (pad should have multiple vias), the charge current and the battery voltage as a function of time. The fast charge current will start to taper off if the part goes into thermal regulation.

The device power dissipation, P , is a function of the charge rate and the voltage drop across the internal PowerFET. It can be calculated from the following equation when a battery pack is being charged :

$$P = [V_{(IN)} - V_{(OUT)}] \times I_{(OUT)} + [V_{(OUT)} - V_{(BAT)}] \times I_{(BAT)} \quad (9)$$

The thermal loop feature reduces the charge current to limit excessive IC junction temperature. It is recommended that the design not run in thermal regulation for typical operating conditions (nominal input voltage and nominal ambient temperatures) and use the feature for non typical situations such as hot environments or higher than normal input source voltage. With that said, the IC will still perform as described, if the thermal loop is always active.

9.2.1.2.3.1 Leakage Current Effects on Battery Capacity

To determine how fast a leakage current on the battery will discharge the battery is an easy calculation. The time from full to discharge can be calculated by dividing the Amp-Hour Capacity of the battery by the leakage current. For a 0.75Ahr battery and a 10 μ A leakage current (750mAHr/0.010mA = 75000 Hours), it would take 75k hours or 8.8 years to discharge. In reality the self discharge of the cell would be much faster so the 10 μ A leakage would be considered negligible.

Typical Applications (continued)

9.2.1.3 Application Performance Curves

SETUP: bq24040 typical applications schematic; $V_{IN} = 5V$, $V_{BAT} = 3.6V$ (unless otherwise indicated)

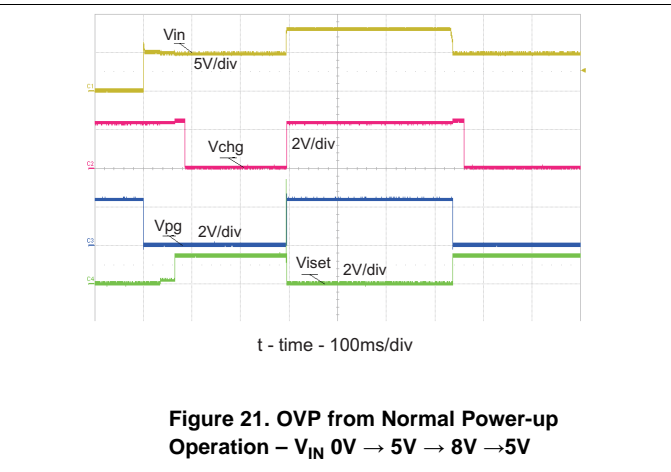
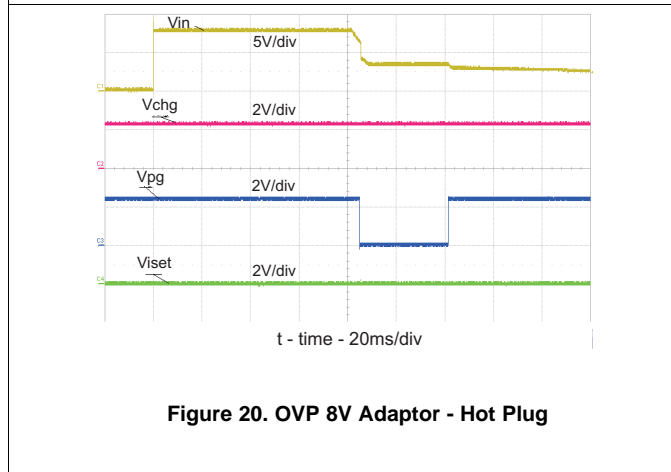
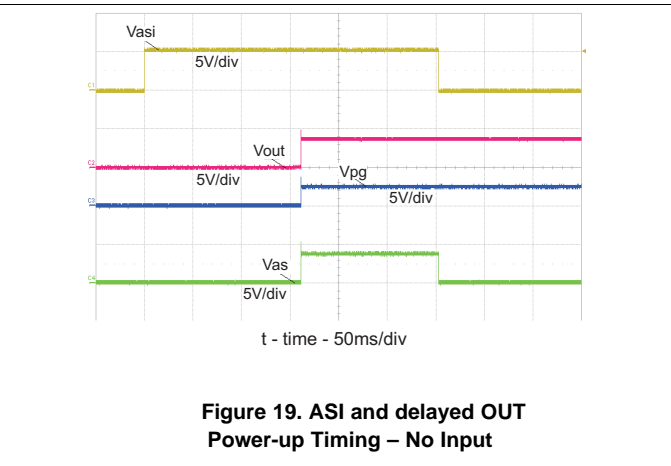
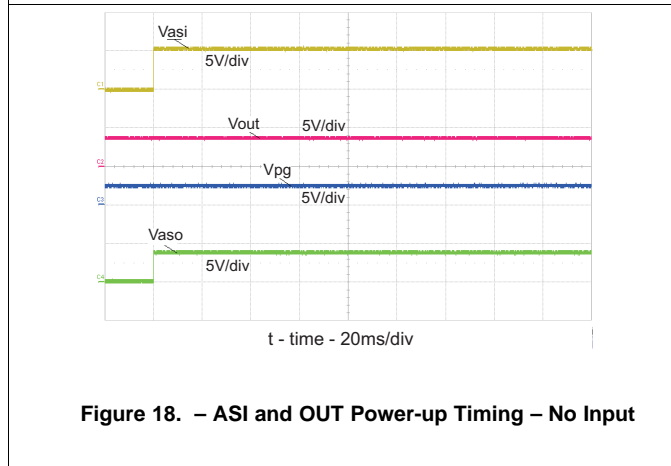
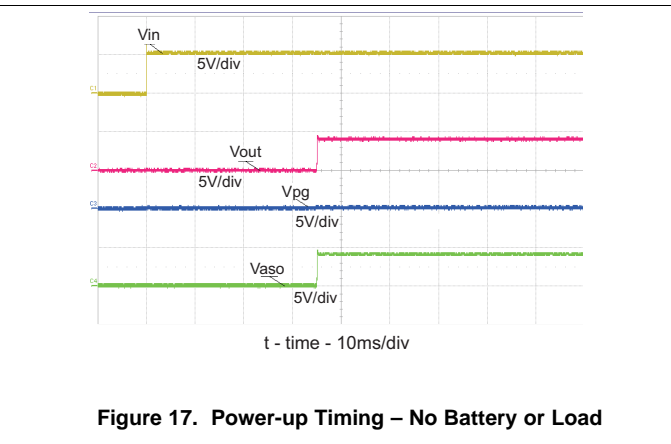
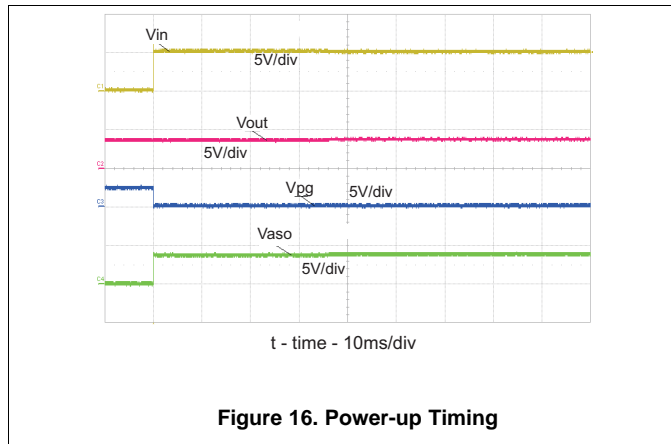

Typical Applications (continued)

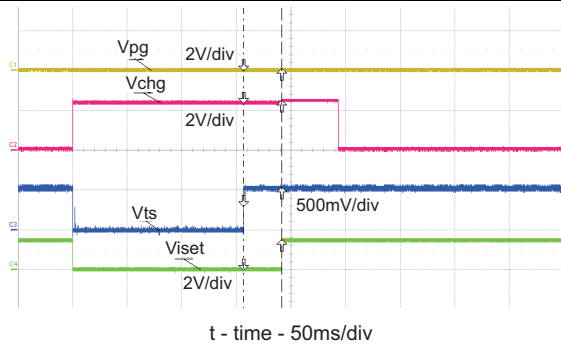
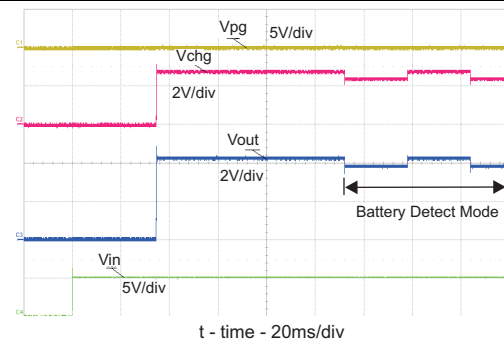

Figure 22. TS Enable and Disable



Fixed 10kΩ resistor, between TS and GND.
Figure 23. Hot Plug Source w/No Battery – Battery Detection

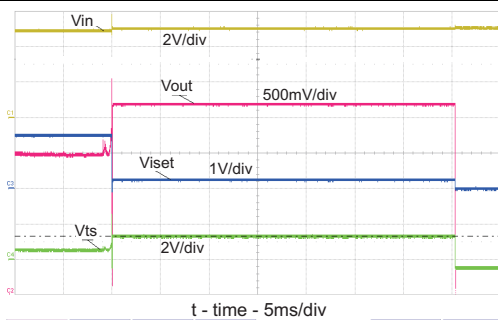

Figure 24. Battery Removal – GND Removed 1st, 42 Ω Load

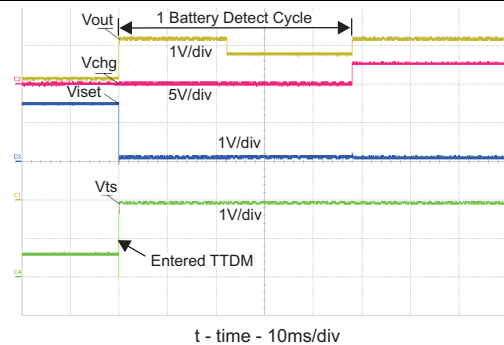
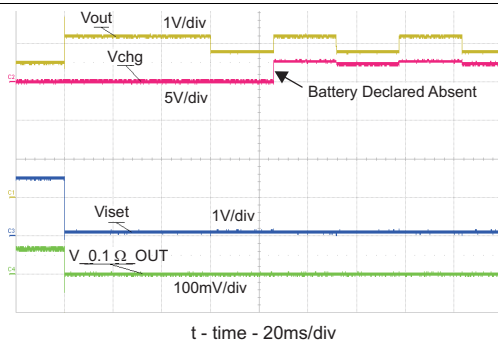
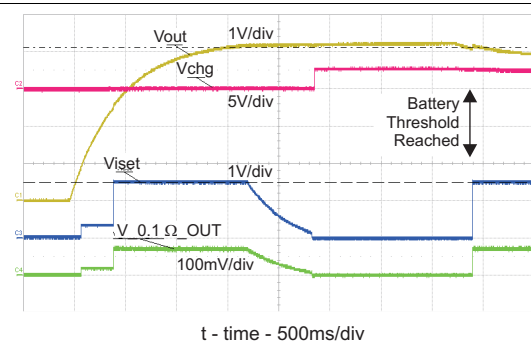

Figure 25. Battery Removal with OUT and TS Disconnect 1st, With 100 Ω Load



Continuous battery detection when not in TTDM

Figure 26. Battery Removal with fixed TS = 0.5V



CH4: I_{OUT} (1A/Div)
Battery voltage swept from 0V to 4.25V to 3.9V.

Figure 27. Battery Charge Profile

Typical Applications (continued)

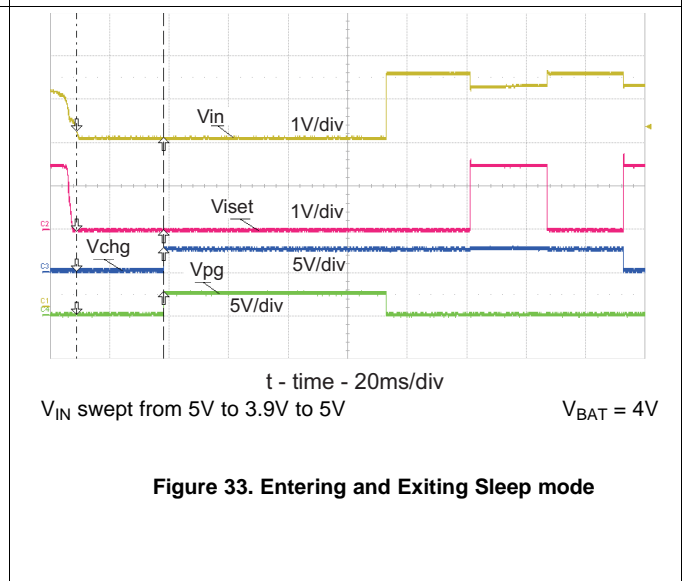
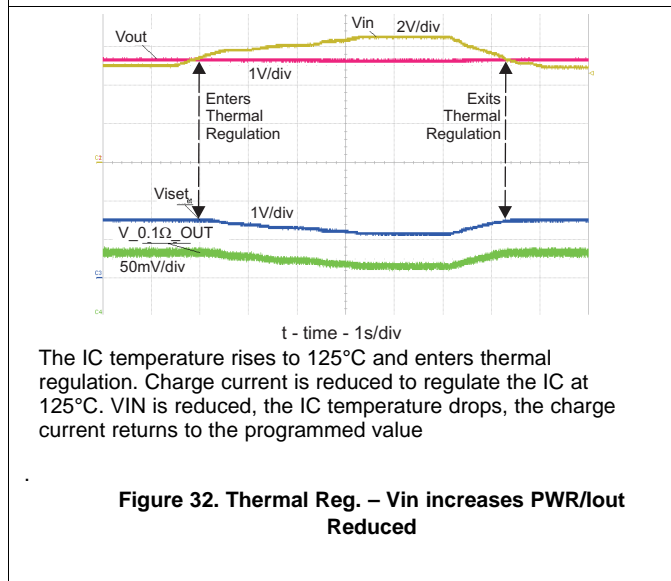
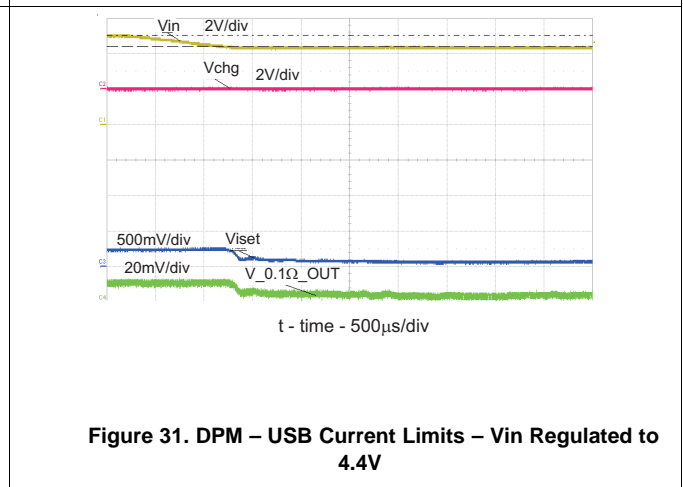
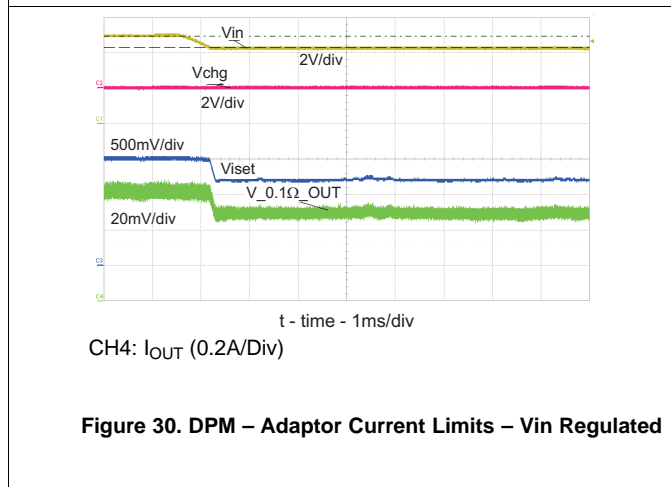
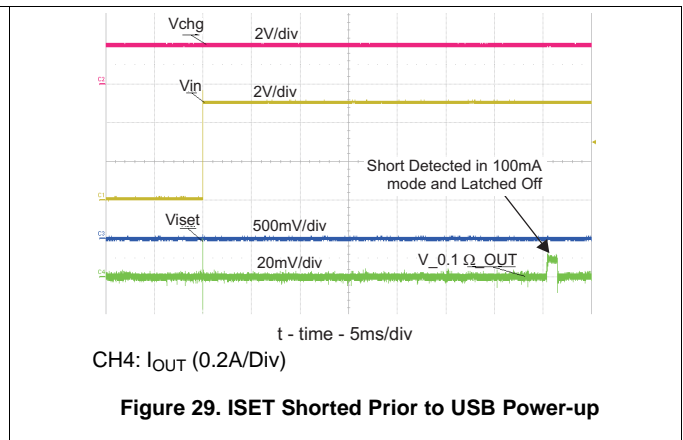
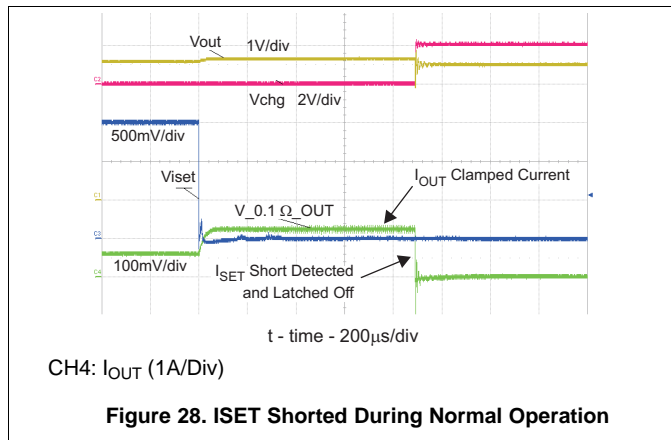

Typical Applications (continued)

9.2.2 Typical Application Circuit: bq24041, with ASI and ASO

$I_{OUT_FAST_CHG} = 540\text{mA}$; $I_{OUT_PRE_CHG} = 108\text{mA}$

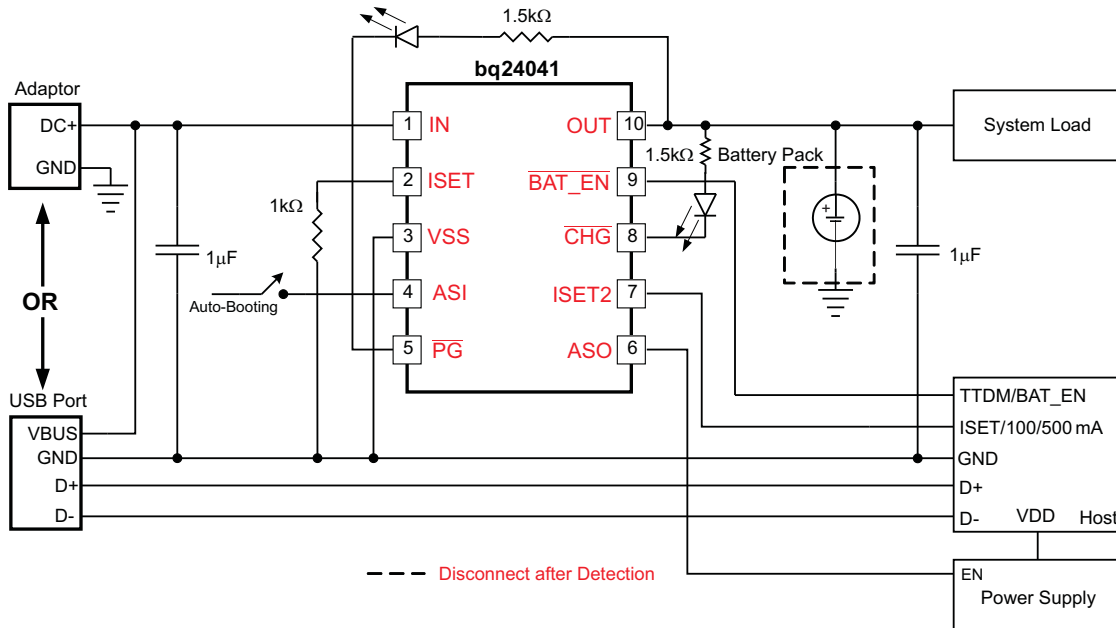

Figure 34. Typical Application Circuit: bq24041, with ASI and ASO

9.2.2.1 Design Requirements

See [Typical Application: bq24040 and bq24045](#) for design requirements.

9.2.2.2 Detailed Design Procedures

See [Typical Application: bq24040 and bq24045](#) for detailed design procedures.

Typical Applications (continued)
9.2.2.3 Application Performance Curves

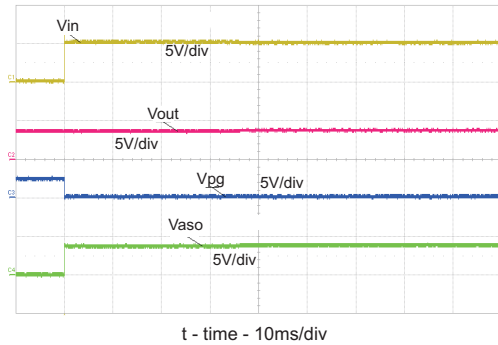
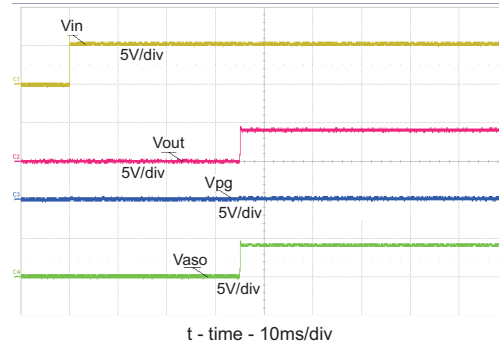
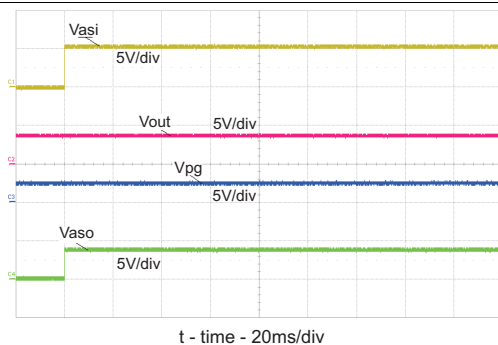
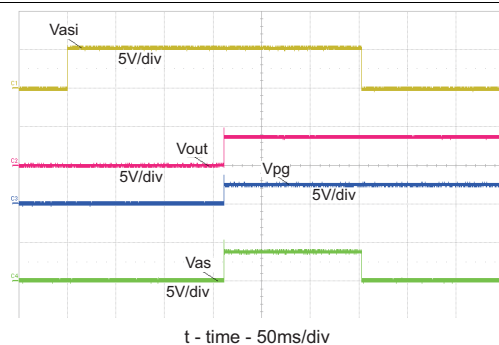
 SETUP: bq24041 typical applications schematic; $V_{IN} = 5V$, $V_{BAT} = 3.6V$ (unless otherwise indicated)

Figure 35. Power-up Timing, bq24041

Figure 36. Power-up Timing – No Battery or Load, bq24041

Figure 37. – ASI and OUT Power-up Timing – No Input, bq24041

Figure 38. ASI and delayed OUT Power-up Timing – No Input, bq24041

10 Power Supply Recommendations

The devices are designed to operate from an input voltage supply range between 3.5 V and 28 V and current capability of at least the maximum designed charge current. This input supply should be well regulated. If located more than a few inches from the bq24040x IN and GND terminals, a larger capacitor is recommended.

11 Layout

11.1 Layout Guidelines

To obtain optimal performance, the decoupling capacitor from IN to GND (thermal pad) and the output filter capacitors from OUT to GND (thermal pad) should be placed as close as possible to the bq2405x, with short trace runs to both IN, OUT and GND (thermal pad).

- All low-current GND connections should be kept separate from the high-current charge or discharge paths from the battery. Use a single-point ground technique incorporating both the small signal ground path and the power ground path.
- The high current charge paths into IN terminal and from the OUT terminal must be sized appropriately for the maximum charge current in order to avoid voltage drops in these traces
- The bq2404x family is packaged in a thermally enhanced MLP package. The package includes a thermal pad to provide an effective thermal contact between the IC and the printed circuit board (PCB); this thermal pad is also the main ground connection for the device. Connect the thermal pad to the PCB ground connection. It is best to use multiple 10mil vias in the power pad of the IC and close enough to conduct the heat to the bottom ground plane. The bottom ground plane should avoid traces that “cut off” the thermal path. The thinner the PCB the less temperature rise. The EVM PCB has a thickness of 0.031 inches and uses 2 oz. (2.8mil thick) copper on top and bottom, and is a good example of optimal thermal performance.

11.2 Layout Example

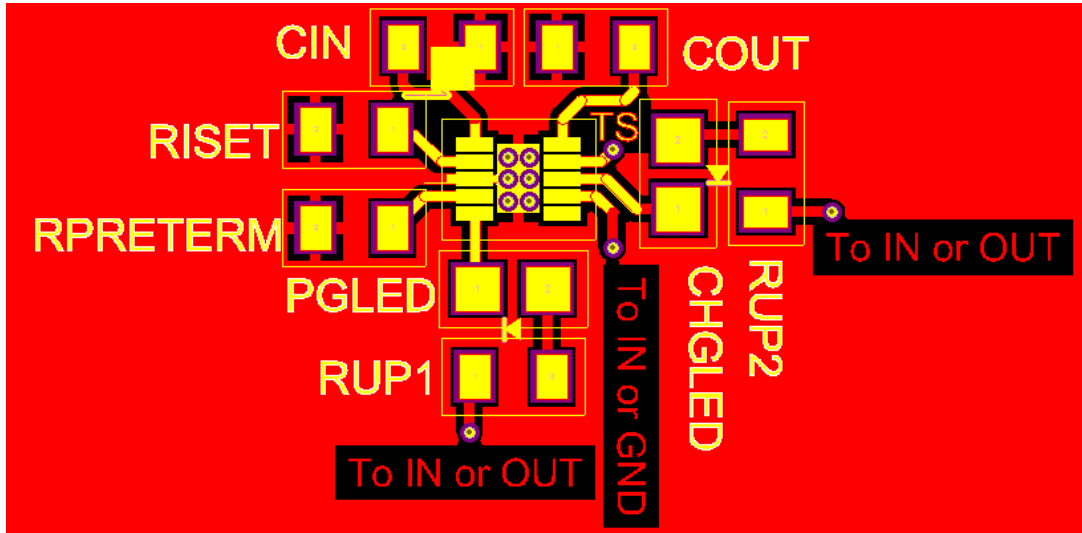

Figure 39. Layout

12 Device and Documentation Support

12.1 Documentation Support

QFN/SON PCB Attachment Application Report, [SLUA271](#)

12.2 Related Links

The table below lists quick access links. Categories include technical documents, support and community resources, tools and software, and quick access to sample or buy.

Table 1. Related Links

PARTS	PRODUCT FOLDER	SAMPLE & BUY	TECHNICAL DOCUMENTS	TOOLS & SOFTWARE	SUPPORT & COMMUNITY
bq24040	Click here	Click here	Click here	Click here	Click here
bq24041	Click here	Click here	Click here	Click here	Click here
bq24045	Click here	Click here	Click here	Click here	Click here

12.3 Trademarks

All trademarks are the property of their respective owners.

12.4 Electrostatic Discharge Caution



These devices have limited built-in ESD protection. The leads should be shorted together or the device placed in conductive foam during storage or handling to prevent electrostatic damage to the MOS gates.

12.5 Glossary

[SLYZ022](#) — *TI Glossary*.

This glossary lists and explains terms, acronyms, and definitions.

13 Mechanical, Packaging, and Orderable Information

The following pages include mechanical packaging and orderable information. This information is the most current data available for the designated devices. This data is subject to change without notice and revision of this document. For browser-based versions of this data sheet, refer to the left-hand navigation.

PACKAGING INFORMATION

Orderable Device	Status (1)	Package Type	Package Drawing	Pins	Package Qty	Eco Plan (2)	Lead/Ball Finish (6)	MSL Peak Temp (3)	Op Temp (°C)	Device Marking (4/5)	Samples
BQ24040DSQR	ACTIVE	WSO	DSQ	10	3000	Green (RoHS & no Sb/Br)	CU NIPDAU	Level-2-260C-1 YEAR	0 to 125	NXE	Samples
BQ24040DSQT	ACTIVE	WSO	DSQ	10	250	Green (RoHS & no Sb/Br)	CU NIPDAU	Level-2-260C-1 YEAR	0 to 125	NXE	Samples
BQ24041DSQR	ACTIVE	WSO	DSQ	10	3000	Green (RoHS & no Sb/Br)	CU NIPDAU	Level-2-260C-1 YEAR		NXF	Samples
BQ24041DSQT	ACTIVE	WSO	DSQ	10	250	Green (RoHS & no Sb/Br)	CU NIPDAU	Level-2-260C-1 YEAR		NXF	Samples
BQ24045DSQR	ACTIVE	WSO	DSQ	10	3000	Green (RoHS & no Sb/Br)	CU NIPDAU	Level-2-260C-1 YEAR		SII	Samples
BQ24045DSQT	ACTIVE	WSO	DSQ	10	250	Green (RoHS & no Sb/Br)	CU NIPDAU	Level-2-260C-1 YEAR		SII	Samples

(1) The marketing status values are defined as follows:

ACTIVE: Product device recommended for new designs.

LIFEBUY: TI has announced that the device will be discontinued, and a lifetime-buy period is in effect.

NRND: Not recommended for new designs. Device is in production to support existing customers, but TI does not recommend using this part in a new design.

PREVIEW: Device has been announced but is not in production. Samples may or may not be available.

OBSELETE: TI has discontinued the production of the device.

(2) Eco Plan - The planned eco-friendly classification: Pb-Free (RoHS), Pb-Free (RoHS Exempt), or Green (RoHS & no Sb/Br) - please check <http://www.ti.com/productcontent> for the latest availability information and additional product content details.

TBD: The Pb-Free/Green conversion plan has not been defined.

Pb-Free (RoHS): TI's terms "Lead-Free" or "Pb-Free" mean semiconductor products that are compatible with the current RoHS requirements for all 6 substances, including the requirement that lead not exceed 0.1% by weight in homogeneous materials. Where designed to be soldered at high temperatures, TI Pb-Free products are suitable for use in specified lead-free processes.

Pb-Free (RoHS Exempt): This component has a RoHS exemption for either 1) lead-based flip-chip solder bumps used between the die and package, or 2) lead-based die adhesive used between the die and leadframe. The component is otherwise considered Pb-Free (RoHS compatible) as defined above.

Green (RoHS & no Sb/Br): TI defines "Green" to mean Pb-Free (RoHS compatible), and free of Bromine (Br) and Antimony (Sb) based flame retardants (Br or Sb do not exceed 0.1% by weight in homogeneous material)

(3) MSL, Peak Temp. - The Moisture Sensitivity Level rating according to the JEDEC industry standard classifications, and peak solder temperature.

(4) There may be additional marking, which relates to the logo, the lot trace code information, or the environmental category on the device.

(5) Multiple Device Markings will be inside parentheses. Only one Device Marking contained in parentheses and separated by a "~" will appear on a device. If a line is indented then it is a continuation of the previous line and the two combined represent the entire Device Marking for that device.

⁽⁶⁾ Lead/Ball Finish - Orderable Devices may have multiple material finish options. Finish options are separated by a vertical ruled line. Lead/Ball Finish values may wrap to two lines if the finish value exceeds the maximum column width.

Important Information and Disclaimer: The information provided on this page represents TI's knowledge and belief as of the date that it is provided. TI bases its knowledge and belief on information provided by third parties, and makes no representation or warranty as to the accuracy of such information. Efforts are underway to better integrate information from third parties. TI has taken and continues to take reasonable steps to provide representative and accurate information but may not have conducted destructive testing or chemical analysis on incoming materials and chemicals. TI and TI suppliers consider certain information to be proprietary, and thus CAS numbers and other limited information may not be available for release.

In no event shall TI's liability arising out of such information exceed the total purchase price of the TI part(s) at issue in this document sold by TI to Customer on an annual basis.

TAPE AND REEL INFORMATION

QUADRANT ASSIGNMENTS FOR PIN 1 ORIENTATION IN TAPE

*All dimensions are nominal

Device	Package Type	Package Drawing	Pins	SPQ	Reel Diameter (mm)	Reel Width W1 (mm)	A0 (mm)	B0 (mm)	K0 (mm)	P1 (mm)	W (mm)	Pin1 Quadrant
BQ24040DSQR	WSON	DSQ	10	3000	180.0	8.4	2.3	2.3	1.15	4.0	8.0	Q2
BQ24040DSQT	WSON	DSQ	10	250	180.0	8.4	2.3	2.3	1.15	4.0	8.0	Q2
BQ24041DSQR	WSON	DSQ	10	3000	179.0	8.4	2.2	2.2	1.2	4.0	8.0	Q2
BQ24041DSQT	WSON	DSQ	10	250	179.0	8.4	2.2	2.2	1.2	4.0	8.0	Q2
BQ24045DSQR	WSON	DSQ	10	3000	180.0	8.4	2.3	2.3	1.15	4.0	8.0	Q2
BQ24045DSQT	WSON	DSQ	10	250	180.0	8.4	2.3	2.3	1.15	4.0	8.0	Q2

TAPE AND REEL BOX DIMENSIONS

*All dimensions are nominal

Device	Package Type	Package Drawing	Pins	SPQ	Length (mm)	Width (mm)	Height (mm)
BQ24040DSQR	WSON	DSQ	10	3000	210.0	185.0	35.0
BQ24040DSQT	WSON	DSQ	10	250	210.0	185.0	35.0
BQ24041DSQR	WSON	DSQ	10	3000	195.0	200.0	45.0
BQ24041DSQT	WSON	DSQ	10	250	195.0	200.0	45.0
BQ24045DSQR	WSON	DSQ	10	3000	210.0	185.0	35.0
BQ24045DSQT	WSON	DSQ	10	250	210.0	185.0	35.0

EXAMPLE BOARD LAYOUT

DSQ0010A

WSON - 0.8 mm max height

PLASTIC SMALL OUTLINE - NO LEAD

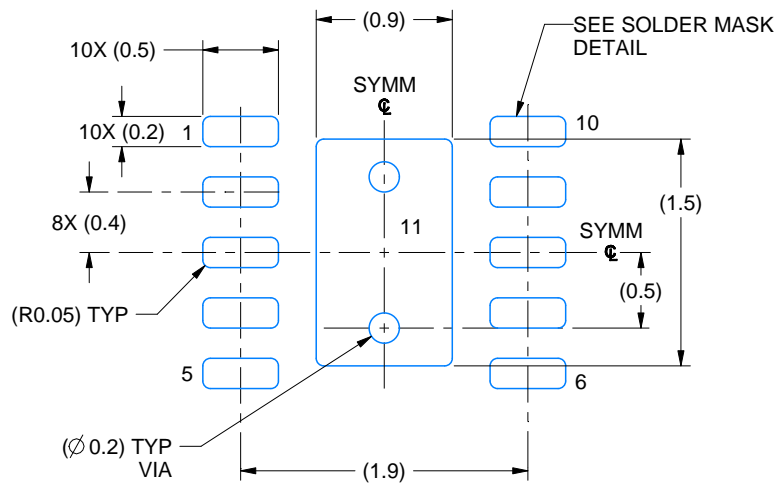

LAND PATTERN EXAMPLE
EXPOSED METAL SHOWN
SCALE: 20X

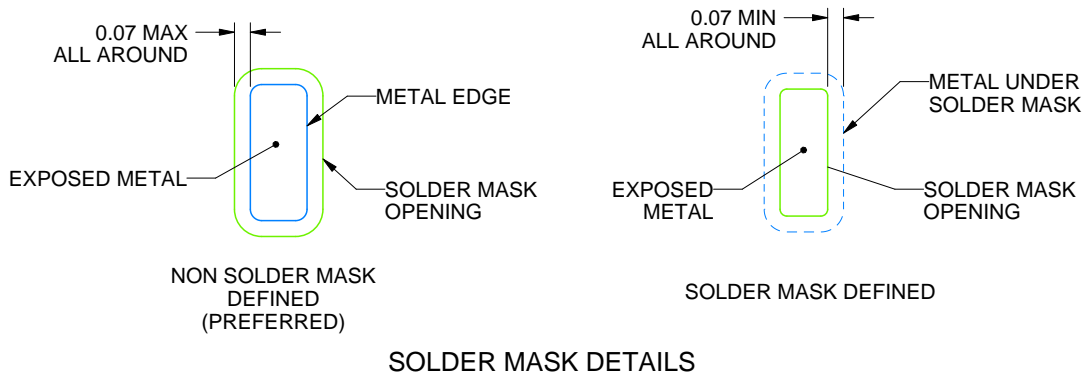

SOLDER MASK DETAILS

4218906/A 04/2019

NOTES: (continued)

- This package is designed to be soldered to a thermal pad on the board. For more information, see Texas Instruments literature number SLUA271 (www.ti.com/lit/slua271).
- Vias are optional depending on application, refer to device data sheet. If any vias are implemented, refer to their locations shown on this view. It is recommended that vias under paste be filled, plugged or tented.

EXAMPLE STENCIL DESIGN

DSQ0010A

WSON - 0.8 mm max height

PLASTIC SMALL OUTLINE - NO LEAD

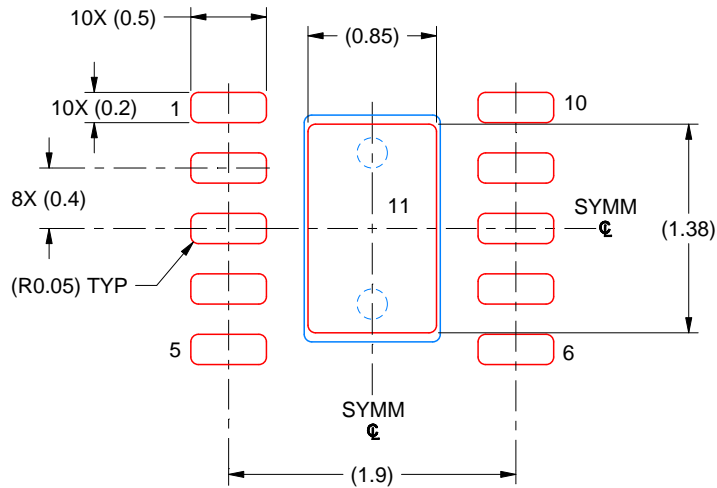

SOLDER PASTE EXAMPLE
BASED ON 0.125 MM THICK STENCIL
SCALE: 20X

EXPOSED PAD 11
87% PRINTED SOLDER COVERAGE BY AREA UNDER PACKAGE

4218906/A 04/2019

NOTES: (continued)

6. Laser cutting apertures with trapezoidal walls and rounded corners may offer better paste release. IPC-7525 may have alternate design recommendations.

IMPORTANT NOTICE AND DISCLAIMER

TI PROVIDES TECHNICAL AND RELIABILITY DATA (INCLUDING DATASHEETS), DESIGN RESOURCES (INCLUDING REFERENCE DESIGNS), APPLICATION OR OTHER DESIGN ADVICE, WEB TOOLS, SAFETY INFORMATION, AND OTHER RESOURCES "AS IS" AND WITH ALL FAULTS, AND DISCLAIMS ALL WARRANTIES, EXPRESS AND IMPLIED, INCLUDING WITHOUT LIMITATION ANY IMPLIED WARRANTIES OF MERCHANTABILITY, FITNESS FOR A PARTICULAR PURPOSE OR NON-INFRINGEMENT OF THIRD PARTY INTELLECTUAL PROPERTY RIGHTS.

These resources are intended for skilled developers designing with TI products. You are solely responsible for (1) selecting the appropriate TI products for your application, (2) designing, validating and testing your application, and (3) ensuring your application meets applicable standards, and any other safety, security, or other requirements. These resources are subject to change without notice. TI grants you permission to use these resources only for development of an application that uses the TI products described in the resource. Other reproduction and display of these resources is prohibited. No license is granted to any other TI intellectual property right or to any third party intellectual property right. TI disclaims responsibility for, and you will fully indemnify TI and its representatives against, any claims, damages, costs, losses, and liabilities arising out of your use of these resources.

TI's products are provided subject to TI's Terms of Sale (www.ti.com/legal/termsofsale.html) or other applicable terms available either on ti.com or provided in conjunction with such TI products. TI's provision of these resources does not expand or otherwise alter TI's applicable warranties or warranty disclaimers for TI products.

Mailing Address: Texas Instruments, Post Office Box 655303, Dallas, Texas 75265
Copyright © 2019, Texas Instruments Incorporated

Looking for pricing, stock, or lifecycle information?

Click below to explore more details on WIN SOURCE:

 [View BQ24041DSQR on WIN SOURCE](#)

 [Texas Instruments](#) Information

Optimize Your Supply Chain with WIN SOURCE Solutions

-  Global Sourcing Solution
-  Obsolete Management
-  Cost Control Management
-  Shortage Management
-  Alternative Solution
-  Excess Inventory Management