



**THE DATASHEET OF  
SN74ALVTH32374KR**



SN54ALVTH32374, SN74ALVTH32374  
2.5-V/3.3-V 32-BIT EDGE-TRIGGERED D-TYPE FLIP-FLOPS  
WITH 3-STATE OUTPUTS

SCES280 – SEPTEMBER 1999

- State-of-the-Art Advanced BiCMOS Technology (ABT) *Widebus*™ Design for 2.5-V and 3.3-V Operation and Low Static Power Dissipation
- Support Mixed-Mode Signal Operation (5-V Input and Output Voltages With 2.3-V to 3.6-V  $V_{CC}$ )
- Typical  $V_{OLP}$  (Output Ground Bounce)  $< 0.8$  V at  $V_{CC} = 3.3$  V,  $T_A = 25^\circ\text{C}$
- High Drive ( $-24/24$  mA at 2.5-V  $V_{CC}$  and  $-32/64$  mA at 3.3-V  $V_{CC}$ )
- $I_{off}$  and Power-Up 3-State Support Hot Insertion
- Use Bus Hold on Data Inputs in Place of External Pullup/Pulldown Resistors to Prevent the Bus From Floating
- Auto3-State Eliminates Bus Current Loading When Output Exceeds  $V_{CC} + 0.5$  V
- Flow-Through Architecture Facilitates Printed Circuit Board Layout
- Distributed  $V_{CC}$  and GND Pin Configuration Minimizes High-Speed Switching Noise
- ESD Protection Exceeds JESD-22
  - 2000-V Human-Body Model
  - 200-V Machine Model (A115-A)
  - 1000-V Charged-Device Model (C101) (A114-A)
- Latch-Up Performance Exceeds 100 mA Per JESD 78, Class II
- Packaged in Plastic Fine-Pitch Ball Grid Array Package

NOTE: For tape and reel order entry:  
The GKER package is abbreviated to KR.

## description

The 'ALVTH32374 devices are 32-bit edge-triggered D-type flip-flops with 3-state outputs designed for 2.5-V or 3.3-V)  $V_{CC}$  operation, but with the capability to provide a TTL interface to a 5-V system environment. These devices are particularly suitable for implementing buffer registers, I/O ports, bidirectional bus drivers, and working registers.

These devices can be used as four 8-bit flip-flops, two 16-bit flip-flops, or one 32-bit flip-flop. On the positive transition of the clock (CLK), the Q outputs of the flip-flops take on the logic levels set up at the data (D) inputs.

A buffered output-enable ( $\overline{OE}$ ) input can be used to place the eight outputs in either a normal logic state (high or low logic levels) or the high-impedance state. In the high-impedance state, the outputs neither load nor drive the bus lines significantly. The high-impedance state and increased drive provide the capability to drive bus lines without interface or pullup components.

$\overline{OE}$  does not affect internal operations of the flip-flop. Old data can be retained or new data can be entered while the outputs are in the high-impedance state.

When  $V_{CC}$  is between 0 and 1.2 V, the device is in the high-impedance state during power up or power down. However, to ensure the high-impedance state above 1.2 V,  $\overline{OE}$  should be tied to  $V_{CC}$  through a pullup resistor; the minimum value of the resistor is determined by the current-sinking capability of the driver.

These devices are fully specified for hot-insertion applications using  $I_{off}$  and power-up 3-state. The  $I_{off}$  circuitry disables the outputs, preventing damaging current backflow through the device when they are powered down. The power-up 3-state circuitry places the outputs in the high-impedance state during power up and power down, which prevents driver conflict.

Active bus-hold circuitry is provided to hold unused or floating data inputs at a valid logic level.

The SN54ALVTH32374 is characterized for operation over the full military temperature range of  $-55^\circ\text{C}$  to  $125^\circ\text{C}$ . The SN74ALVTH32374 is characterized for operation from  $-40^\circ\text{C}$  to  $85^\circ\text{C}$ .



Please be aware that an important notice concerning availability, standard warranty, and use in critical applications of Texas Instruments semiconductor products and disclaimers thereto appears at the end of this data sheet.

Widebus is a trademark of Texas Instruments Incorporated.

UNLESS OTHERWISE NOTED this document contains PRODUCTION DATA information current as of publication date. Products conform to specifications per the terms of Texas Instruments standard warranty. Production processing does not necessarily include testing of all parameters.

 **TEXAS  
INSTRUMENTS**

POST OFFICE BOX 655303 • DALLAS, TEXAS 75265

Copyright © 1999, Texas Instruments Incorporated

**SN54ALVTH32374, SN74ALVTH32374**  
**2.5-V/3.3-V 32-BIT EDGE-TRIGGERED D-TYPE FLIP-FLOPS**  
**WITH 3-STATE OUTPUTS**

SCES280 – SEPTEMBER 1999

**FUNCTION TABLE**  
 (each flip-flop)

INPUTS			OUTPUT Q
$\overline{OE}$	CLK	D	
L	↑	H	H
L	↑	L	L
L	H or L	X	$Q_0$
H	X	X	Z

**GKE PACKAGE**  
 (TOP VIEW)

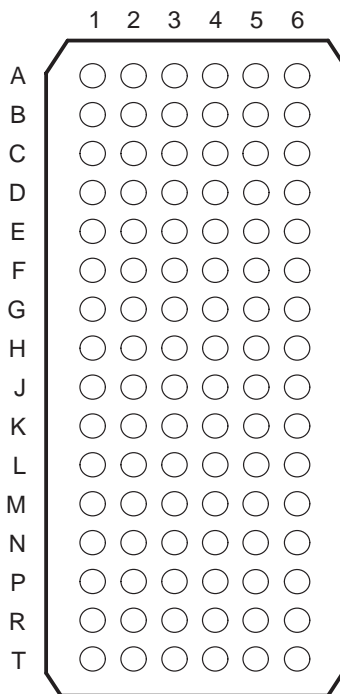

**terminal assignments**

	1	2	3	4	5	6
<b>A</b>	1Q2	1Q1	$\overline{1OE}$	1CLK	1D1	1D2
<b>B</b>	1Q4	1Q3	GND	GND	1D3	1D4
<b>C</b>	1Q6	1Q5	1V <sub>CC</sub>	1V <sub>CC</sub>	1D5	1D6
<b>D</b>	1Q8	1Q7	GND	GND	1D7	1D8
<b>E</b>	2Q2	2Q1	GND	GND	2D1	2D2
<b>F</b>	2Q4	2Q3	1V <sub>CC</sub>	1V <sub>CC</sub>	2D3	2D4
<b>G</b>	2Q6	2Q5	GND	GND	2D5	2D6
<b>H</b>	2Q7	2Q8	$\overline{2OE}$	2CLK	2D8	2D7
<b>J</b>	3Q2	3Q1	$\overline{3OE}$	3CLK	3D1	3D2
<b>K</b>	3Q4	3Q3	GND	GND	3D3	3D4
<b>L</b>	3Q6	3Q5	2V <sub>CC</sub>	2V <sub>CC</sub>	3D5	3D6
<b>M</b>	3Q8	3Q7	GND	GND	3D7	3D8
<b>N</b>	4Q2	4Q1	GND	GND	4D1	4D2
<b>P</b>	4Q4	4Q3	2V <sub>CC</sub>	2V <sub>CC</sub>	4D3	4D4
<b>R</b>	4Q6	4Q5	GND	GND	4D5	4D6
<b>T</b>	4Q7	4Q8	$\overline{4OE}$	4CLK	4D8	4D7

**SN54ALVTH32374, SN74ALVTH32374**  
**2.5-V/3.3-V 32-BIT EDGE-TRIGGERED D-TYPE FLIP-FLOPS**  
**WITH 3-STATE OUTPUTS**

SCES280 – SEPTEMBER 1999

**logic diagram (positive logic)**

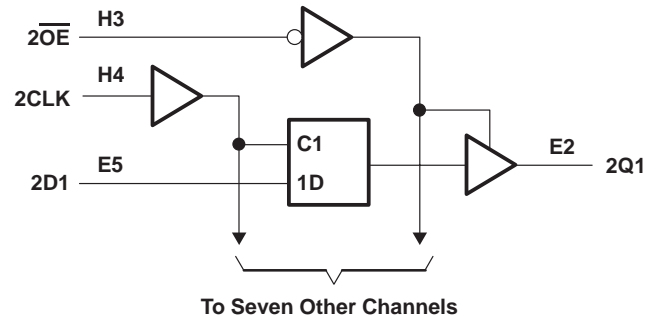
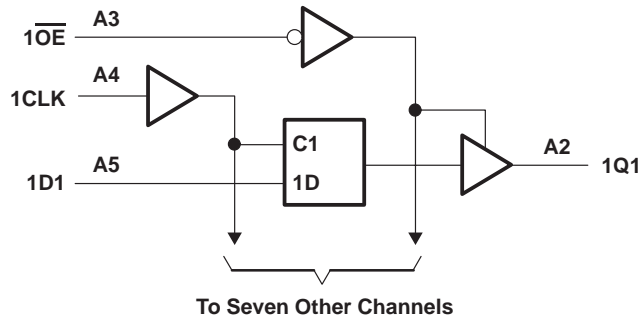

NOTE A: 1V<sub>CC</sub> is associated with these channels.

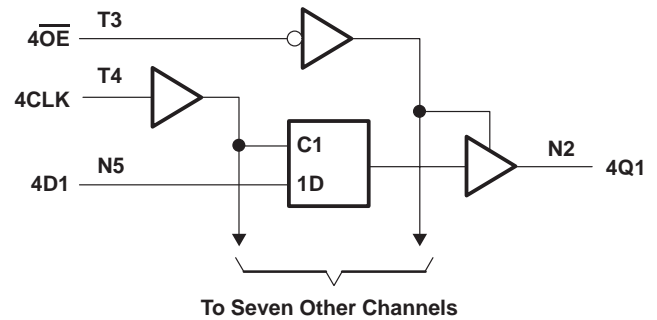
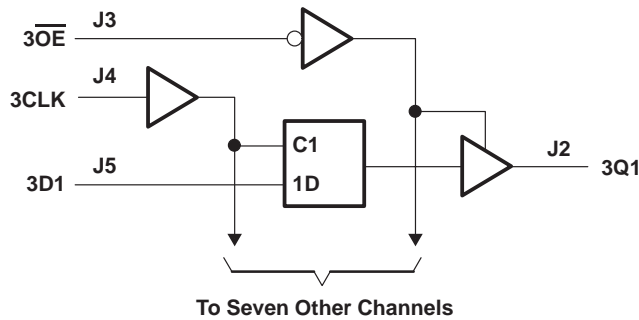

NOTE B: 2V<sub>CC</sub> is associated with these channels.

**absolute maximum ratings over operating free-air temperature range (unless otherwise noted)†**

Supply voltage range, V <sub>CC</sub> .....	-0.5 V to 4.6 V
Input voltage range, V <sub>I</sub> (see Note 1) .....	-0.5 V to 7 V
Voltage range applied to any output in the high-impedance or power-off state, V <sub>O</sub> (see Note 1) .....	-0.5 V to 7 V
Voltage range applied to any output in the high state, V <sub>O</sub> (see Note 1) .....	-0.5 V to 7 V
Output current in the low state, I <sub>O</sub> : SN54ALVTH32374 .....	96 mA
SN74ALVTH32374 .....	128 mA
Output current in the high state, I <sub>O</sub> : SN54ALVTH32374 .....	-48 mA
SN74ALVTH32374 .....	-64 mA
Input clamp current, I <sub>IK</sub> (V <sub>I</sub> < 0) .....	-50 mA
Output clamp current, I <sub>OK</sub> (V <sub>O</sub> < 0) .....	-50 mA
Package thermal impedance, θ <sub>JA</sub> (see Note 2) .....	40°C/W
Storage temperature range, T <sub>stg</sub> .....	-65°C to 150°C

† Stresses beyond those listed under "absolute maximum ratings" may cause permanent damage to the device. These are stress ratings only, and functional operation of the device at these or any other conditions beyond those indicated under "recommended operating conditions" is not implied. Exposure to absolute-maximum-rated conditions for extended periods may affect device reliability.

- NOTES: 1. The input and output negative-voltage ratings may be exceeded if the input and output clamp-current ratings are observed.  
 2. The package thermal impedance is calculated in accordance with JESD 51.

# SN54ALVTH32374, SN74ALVTH32374

## 2.5-V/3.3-V 32-BIT EDGE-TRIGGERED D-TYPE FLIP-FLOPS

### WITH 3-STATE OUTPUTS

SCES280 – SEPTEMBER 1999

#### recommended operating conditions, $V_{CC} = 2.5\text{ V} \pm 0.2\text{ V}$ (see Note 3)

		SN54ALVTH32374			SN74ALVTH32374			UNIT
		MIN	TYP	MAX	MIN	TYP	MAX	
$V_{CC}$	Supply voltage	2.3		2.7	2.3		2.7	V
$V_{IH}$	High-level input voltage	1.7			1.7			V
$V_{IL}$	Low-level input voltage			0.7			0.7	V
$V_I$	Input voltage	0	$V_{CC}$	5.5	0	$V_{CC}$	5.5	V
$I_{OH}$	High-level output current			-6			-8	mA
$I_{OL}$	Low-level output current			6			8	mA
	Low-level output current; current duty cycle $\leq 50\%$ ; $f \geq 1\text{ kHz}$			18			24	
$\Delta t/\Delta v$	Input transition rise or fall rate	Outputs enabled		10	10		ns/V	
$\Delta t/\Delta V_{CC}$	Power-up ramp rate	200			200			$\mu\text{s/V}$
$T_A$	Operating free-air temperature	-55		125	-40		85	$^{\circ}\text{C}$

NOTE 3: All unused control inputs of the device must be held at  $V_{CC}$  or GND to ensure proper device operation. Refer to the TI application report, *Implications of Slow or Floating CMOS Inputs*, literature number SCBA004.

#### recommended operating conditions, $V_{CC} = 3.3\text{ V} \pm 0.3\text{ V}$ (see Note 3)

		SN54ALVTH32374			SN74ALVTH32374			UNIT
		MIN	TYP	MAX	MIN	TYP	MAX	
$V_{CC}$	Supply voltage	3		3.6	3		3.6	V
$V_{IH}$	High-level input voltage	2			2			V
$V_{IL}$	Low-level input voltage			0.8			0.8	V
$V_I$	Input voltage	0	$V_{CC}$	5.5	0	$V_{CC}$	5.5	V
$I_{OH}$	High-level output current			-24			-32	mA
$I_{OL}$	Low-level output current			24			32	mA
	Low-level output current; current duty cycle $\leq 50\%$ ; $f \geq 1\text{ kHz}$			48			64	
$\Delta t/\Delta v$	Input transition rise or fall rate	Outputs enabled		10	10		ns/V	
$\Delta t/\Delta V_{CC}$	Power-up ramp rate	200			200			$\mu\text{s/V}$
$T_A$	Operating free-air temperature	-55		125	-40		85	$^{\circ}\text{C}$

NOTE 3: All unused control inputs of the device must be held at  $V_{CC}$  or GND to ensure proper device operation. Refer to the TI application report, *Implications of Slow or Floating CMOS Inputs*, literature number SCBA004.

**SN54ALVTH32374, SN74ALVTH32374**  
**2.5-V/3.3-V 32-BIT EDGE-TRIGGERED D-TYPE FLIP-FLOPS**  
**WITH 3-STATE OUTPUTS**

SCES280 – SEPTEMBER 1999

**electrical characteristics over recommended operating free-air temperature range,**  
 **$V_{CC} = 2.5\text{ V} \pm 0.2\text{ V}$  (unless otherwise noted)**

PARAMETER		TEST CONDITIONS	SN54ALVTH32374		SN74ALVTH32374		UNIT
			MIN	TYP†	MAX	MIN	
$V_{IK}$		$V_{CC} = 2.3\text{ V}$ , $I_I = -18\text{ mA}$			-1.2		V
$V_{OH}$		$V_{CC} = 2.3\text{ V to }2.7\text{ V}$ , $I_{OH} = -100\text{ }\mu\text{A}$	$V_{CC}-0.2$		$V_{CC}-0.2$		V
		$V_{CC} = 2.3\text{ V}$	1.8		1.8		
$V_{OL}$		$V_{CC} = 2.3\text{ V to }2.7\text{ V}$ , $I_{OL} = 100\text{ }\mu\text{A}$	0.2		0.2		V
		$V_{CC} = 2.3\text{ V}$	0.4				
			0.4		0.4		
			0.5		0.5		
$I_I$	Control inputs	$V_{CC} = 2.7\text{ V}$ , $V_I = V_{CC}$ or GND	$\pm 1$		$\pm 1$		$\mu\text{A}$
		$V_{CC} = 0$ or $2.7\text{ V}$ , $V_I = 5.5\text{ V}$	10		10		
	Data inputs	$V_{CC} = 2.7\text{ V}$ , $V_I = 5.5\text{ V}$	10		10		
		$V_{CC} = 2.7\text{ V}$ , $V_I = V_{CC}$	1		1		
$I_{off}$		$V_{CC} = 0$ , $V_I$ or $V_O = 0$ to $4.5\text{ V}$			$\pm 100$		$\mu\text{A}$
$I_{BHL}^\ddagger$		$V_{CC} = 2.3\text{ V}$ , $V_I = 0.7\text{ V}$	115		115		$\mu\text{A}$
$I_{BHH}^\S$		$V_{CC} = 2.3\text{ V}$ , $V_I = 1.7\text{ V}$	-10		-10		$\mu\text{A}$
$I_{BHLO}^\P$		$V_{CC} = 2.7\text{ V}$ , $V_I = 0$ to $V_{CC}$	300		300		$\mu\text{A}$
$I_{BHHO}^\#$		$V_{CC} = 2.7\text{ V}$ , $V_I = 0$ to $V_{CC}$	-300		-300		$\mu\text{A}$
$I_{EX}^{\ \}$		$V_{CC} = 2.3\text{ V}$ , $V_O = 5.5\text{ V}$	125		125		$\mu\text{A}$
$I_{OZ(PU/PD)}^*$		$V_{CC} \leq 1.2\text{ V}$ , $V_O = 0.5\text{ V to }V_{CC}$ , $V_I = \text{GND or }V_{CC}$ , $\overline{OE} = \text{don't care}$	$\pm 100$		$\pm 100$		$\mu\text{A}$
$I_{OZH}$		$V_{CC} = 2.7\text{ V}$ , $V_O = 2.3\text{ V}$ , $V_I = 0.7\text{ V or }1.7\text{ V}$	5		5		$\mu\text{A}$
$I_{OZL}$		$V_{CC} = 2.7\text{ V}$ , $V_O = 0.5\text{ V}$ , $V_I = 0.7\text{ V or }1.7\text{ V}$	-5		-5		$\mu\text{A}$
$I_{CC}$		$V_{CC} = 2.7\text{ V}$ , $I_O = 0$ , $V_I = V_{CC}$ or GND	Outputs high		0.04 0.1		mA
			Outputs low		2.3 4.5		
			Outputs disabled		0.04 0.1		
$C_i$		$V_{CC} = 2.5\text{ V}$ , $V_I = 2.5\text{ V or }0$	3.5		3.5		pF
$C_o$		$V_{CC} = 2.5\text{ V}$ , $V_O = 2.5\text{ V or }0$	6		6		pF

† All typical values are at  $V_{CC} = 2.5\text{ V}$ ,  $T_A = 25^\circ\text{C}$ .

‡ The bus-hold circuit can sink at least the minimum low sustaining current at  $V_{IL}$  max.  $I_{BHL}$  should be measured after lowering  $V_{IN}$  to GND and then raising it to  $V_{IL}$  max.

§ The bus-hold circuit can source at least the minimum high sustaining current at  $V_{IH}$  min.  $I_{BHH}$  should be measured after raising  $V_{IN}$  to  $V_{CC}$  and then lowering it to  $V_{IH}$  min.

¶ An external driver must source at least  $I_{BHLO}$  to switch this node from low to high.

# An external driver must sink at least  $I_{BHHO}$  to switch this node from high to low.

|| Current into an output in the high state when  $V_O > V_{CC}$

\*High-impedance state during power up or power down

# SN54ALVTH32374, SN74ALVTH32374

## 2.5-V/3.3-V 32-BIT EDGE-TRIGGERED D-TYPE FLIP-FLOPS

### WITH 3-STATE OUTPUTS

SCES280 – SEPTEMBER 1999

electrical characteristics over recommended operating free-air temperature range,  
 $V_{CC} = 3.3\text{ V} \pm 0.3\text{ V}$  (unless otherwise noted)

PARAMETER	TEST CONDITIONS		SN54ALVTH32374			SN74ALVTH32374			UNIT	
			MIN	TYP†	MAX	MIN	TYP†	MAX		
$V_{IK}$	$V_{CC} = 3\text{ V}$ , $I_I = -18\text{ mA}$		-1.2			-1.2			V	
$V_{OH}$	$V_{CC} = 3\text{ V to } 3.6\text{ V}$ , $I_{OH} = -100\text{ }\mu\text{A}$		$V_{CC}-0.2$			$V_{CC}-0.2$			V	
	$V_{CC} = 3\text{ V}$	$I_{OH} = -24\text{ mA}$	2			2				
$V_{OL}$	$V_{CC} = 3\text{ V to } 3.6\text{ V}$ , $I_{OL} = 100\text{ }\mu\text{A}$		0.2			0.2			V	
	$V_{CC} = 3\text{ V}$	$I_{OL} = 16\text{ mA}$				0.4				
		$I_{OL} = 24\text{ mA}$	0.5							
		$I_{OL} = 32\text{ mA}$				0.5				
		$I_{OL} = 48\text{ mA}$	0.55							
$I_I$	Control inputs	$V_{CC} = 3.6\text{ V}$ , $V_I = V_{CC}$ or GND	$\pm 1$			$\pm 1$			$\mu\text{A}$	
		$V_{CC} = 0$ or $3.6\text{ V}$ , $V_I = 5.5\text{ V}$	10			10				
	Data inputs	$V_{CC} = 3.6\text{ V}$	$V_I = 5.5\text{ V}$	10			10			
			$V_I = V_{CC}$	1			1			
		$V_I = 0$	-5			-5				
$I_{off}$	$V_{CC} = 0$ ,	$V_I$ or $V_O = 0$ to $4.5\text{ V}$				$\pm 100$			$\mu\text{A}$	
$I_{BHL}^{\ddagger}$	$V_{CC} = 3\text{ V}$ ,	$V_I = 0.8\text{ V}$	75			75			$\mu\text{A}$	
$I_{BHH}^{\S}$	$V_{CC} = 3\text{ V}$ ,	$V_I = 2\text{ V}$	-75			-75			$\mu\text{A}$	
$I_{BHLO}^{\text{¶}}$	$V_{CC} = 3.6\text{ V}$ ,	$V_I = 0$ to $V_{CC}$	500			500			$\mu\text{A}$	
$I_{BHHO}^{\#}$	$V_{CC} = 3.6\text{ V}$ ,	$V_I = 0$ to $V_{CC}$	-500			-500			$\mu\text{A}$	
$I_{EX}^{\parallel}$	$V_{CC} = 3\text{ V}$ ,	$V_O = 5.5\text{ V}$	125			125			$\mu\text{A}$	
$I_{OZ(PU/PD)}^{\star}$	$V_{CC} \leq 1.2\text{ V}$ , $V_O = 0.5\text{ V}$ to $V_{CC}$ , $V_I = \text{GND}$ or $V_{CC}$ , $\overline{OE} = \text{don't care}$		$\pm 100$			$\pm 100$			$\mu\text{A}$	
$I_{OZH}$	$V_{CC} = 3.6\text{ V}$	$V_O = 3\text{ V}$ , $V_I = 0.8\text{ V}$ or $2\text{ V}$	5			5			$\mu\text{A}$	
$I_{OZL}$	$V_{CC} = 3.6\text{ V}$	$V_O = 0.5\text{ V}$ , $V_I = 0.8\text{ V}$ or $2\text{ V}$	-5			-5			$\mu\text{A}$	
$I_{CC}$	$V_{CC} = 3.6\text{ V}$ , $I_O = 0$ , $V_I = V_{CC}$ or GND	Outputs high	0.07 0.1		0.07 0.1				mA	
		Outputs low	3.2 5		3.2 5					
		Outputs disabled	0.07 0.1		0.07 0.1					
$\Delta I_{CC}^{\square}$	$V_{CC} = 3\text{ V to } 3.6\text{ V}$ , One input at $V_{CC} - 0.6\text{ V}$ , Other inputs at $V_{CC}$ or GND		0.4			0.4			mA	
$C_i$	$V_{CC} = 3.3\text{ V}$ ,	$V_I = 3.3\text{ V}$ or 0	3.5			3.5			pF	
$C_o$	$V_{CC} = 3.3\text{ V}$ ,	$V_O = 3.3\text{ V}$ or 0	6			6			pF	

† All typical values are at  $V_{CC} = 3.3\text{ V}$ ,  $T_A = 25^\circ\text{C}$ .

‡ The bus-hold circuit can sink at least the minimum low sustaining current at  $V_{IL}$  max.  $I_{BHL}$  should be measured after lowering  $V_{IN}$  to GND and then raising it to  $V_{IL}$  max.

§ The bus-hold circuit can source at least the minimum high sustaining current at  $V_{IH}$  min.  $I_{BHH}$  should be measured after raising  $V_{IN}$  to  $V_{CC}$  and then lowering it to  $V_{IH}$  min.

¶ An external driver must source at least  $I_{BHLO}$  to switch this node from low to high.

# An external driver must sink at least  $I_{BHHO}$  to switch this node from high to low.

|| Current into an output in the high state when  $V_O > V_{CC}$

☆ High-impedance state during power up or power down

□ This is the increase in supply current for each input that is at the specified TTL voltage level rather than  $V_{CC}$  or GND.

PRODUCT PREVIEW information concerns products in the formative or design phase of development. Characteristic data and other specifications are design goals. Texas Instruments reserves the right to change or discontinue these products without notice.



**SN54ALVTH32374, SN74ALVTH32374**  
**2.5-V/3.3-V 32-BIT EDGE-TRIGGERED D-TYPE FLIP-FLOPS**  
**WITH 3-STATE OUTPUTS**

SCES280 – SEPTEMBER 1999

**timing requirements over recommended operating free-air temperature range,  $V_{CC} = 2.5\text{ V} \pm 0.2\text{ V}$  (unless otherwise noted) (see Figure 1)**

		SN54ALVTH32374		SN74ALVTH32374		UNIT
		MIN	MAX	MIN	MAX	
$f_{\text{clock}}$	Clock frequency	150		150		MHz
$t_w$	Pulse duration, CLK high or low	1.5		1.5		ns
$t_{\text{su}}$	Setup time, data before CLK $\uparrow$	Data high	1.1	1		ns
		Data low	1.4	1.3		
$t_h$	Hold time, data after CLK $\uparrow$	Data high	0.6	0.5		ns
		Data low	0.9	0.8		

**timing requirements over recommended operating free-air temperature range,  $V_{CC} = 3.3\text{ V} \pm 0.3\text{ V}$  (unless otherwise noted) (see Figure 2)**

		SN54ALVTH32374		SN74ALVTH32374		UNIT
		MIN	MAX	MIN	MAX	
$f_{\text{clock}}$	Clock frequency	250		250		MHz
$t_w$	Pulse duration, CLK high or low	1.5		1.5		ns
$t_{\text{su}}$	Setup time, data before CLK $\uparrow$	Data high	1.1	1		ns
		Data low	1.6	1.5		
$t_h$	Hold time, data after CLK $\uparrow$	Data high	0.6	0.5		ns
		Data low	1.1	1		

**switching characteristics over recommended operating free-air temperature range,  $C_L = 30\text{ pF}$ ,  $V_{CC} = 2.5\text{ V} \pm 0.2\text{ V}$  (unless otherwise noted) (see Figure 1)**

PARAMETER	FROM (INPUT)	TO (OUTPUT)	SN54ALVTH32374		SN74ALVTH32374		UNIT
			MIN	MAX	MIN	MAX	
$f_{\text{max}}$			150		150		MHz
$t_{\text{PLH}}$	CLK	Q	1.4	3.9	1.5	3.8	ns
$t_{\text{PHL}}$			1.4	3.9	1.5	3.8	
$t_{\text{PZH}}$	$\overline{\text{OE}}$	Q	1	4.2	1	4.1	ns
$t_{\text{PZL}}$			1	3.8	1	3.7	
$t_{\text{PHZ}}$	$\overline{\text{OE}}$	Q	1.7	4.3	1.8	4.2	ns
$t_{\text{PLZ}}$			1	3.5	1	3.4	

**switching characteristics over recommended operating free-air temperature range,  $C_L = 50\text{ pF}$ ,  $V_{CC} = 3.3\text{ V} \pm 0.3\text{ V}$  (unless otherwise noted) (see Figure 2)**

PARAMETER	FROM (INPUT)	TO (OUTPUT)	SN54ALVTH32374		SN74ALVTH32374		UNIT
			MIN	MAX	MIN	MAX	
$f_{\text{max}}$			250		250		MHz
$t_{\text{PLH}}$	CLK	Q	1	3.4	1	3.2	ns
$t_{\text{PHL}}$			1	3.3	1	3.2	
$t_{\text{PZH}}$	$\overline{\text{OE}}$	Q	1	3.9	1	3.8	ns
$t_{\text{PZL}}$			1	3.4	1	3.3	
$t_{\text{PHZ}}$	$\overline{\text{OE}}$	Q	1	4.7	1	4.6	ns
$t_{\text{PLZ}}$			1	4.4	1	4.2	

PRODUCT PREVIEW information concerns products in the formative or design phase of development. Characteristic data and other specifications are design goals. Texas Instruments reserves the right to change or discontinue these products without notice.



SN54ALVTH32374, SN74ALVTH32374  
 2.5-V/3.3-V 32-BIT EDGE-TRIGGERED D-TYPE FLIP-FLOPS  
 WITH 3-STATE OUTPUTS

SCES280 – SEPTEMBER 1999

PARAMETER MEASUREMENT INFORMATION

$V_{CC} = 2.5\text{ V} \pm 0.2\text{ V}$

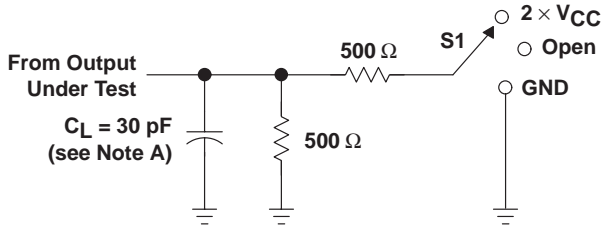

LOAD CIRCUIT

TEST	S1
$t_{PLH}/t_{PHL}$	Open
$t_{PLZ}/t_{PZL}$	2 $\times V_{CC}$
$t_{PHZ}/t_{PZH}$	GND

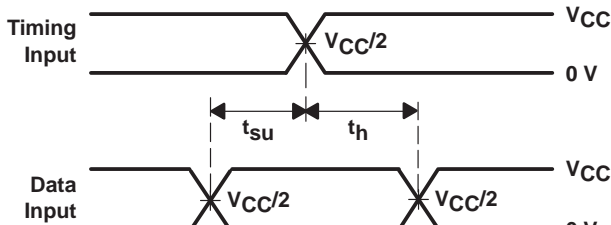

VOLTAGE WAVEFORMS  
 SETUP AND HOLD TIMES

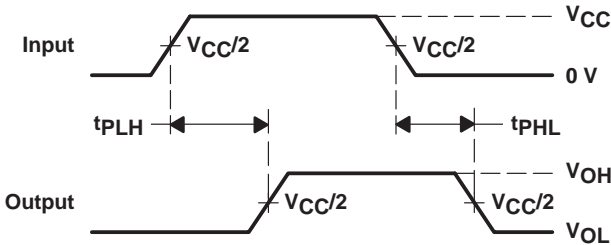

VOLTAGE WAVEFORMS  
 PROPAGATION DELAY TIMES

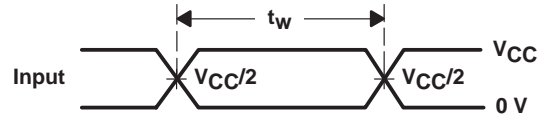

VOLTAGE WAVEFORMS  
 PULSE DURATION

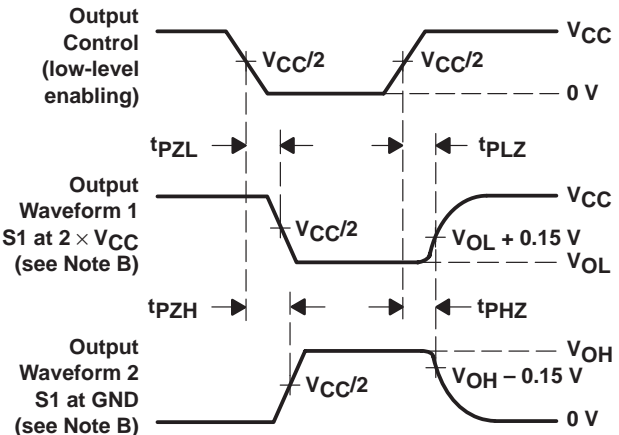

VOLTAGE WAVEFORMS  
 ENABLE AND DISABLE TIMES

- NOTES: A.  $C_L$  includes probe and jig capacitance.  
 B. Waveform 1 is for an output with internal conditions such that the output is low except when disabled by the output control. Waveform 2 is for an output with internal conditions such that the output is high except when disabled by the output control.  
 C. All input pulses are supplied by generators having the following characteristics: PRR  $\leq 10\text{ MHz}$ ,  $Z_O = 50\ \Omega$ ,  $t_r \leq 2\text{ ns}$ ,  $t_f \leq 2\text{ ns}$ .  
 D. The outputs are measured one at a time with one transition per measurement.

Figure 1. Load Circuit and Voltage Waveforms

SN54ALVTH32374, SN74ALVTH32374  
2.5-V/3.3-V 32-BIT EDGE-TRIGGERED D-TYPE FLIP-FLOPS  
WITH 3-STATE OUTPUTS

SCES280 – SEPTEMBER 1999

**PARAMETER MEASUREMENT INFORMATION**

$V_{CC} = 3.3\text{ V} \pm 0.3\text{ V}$

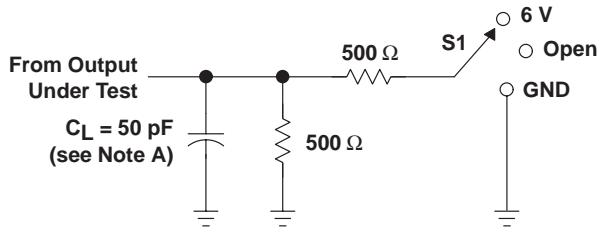

**LOAD CIRCUIT**

TEST	S1
$t_{PLH}/t_{PHL}$	Open
$t_{PLZ}/t_{PZL}$	6 V
$t_{PHZ}/t_{PZH}$	GND

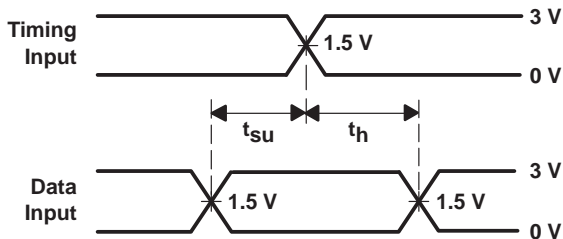

**VOLTAGE WAVEFORMS  
SETUP AND HOLD TIMES**

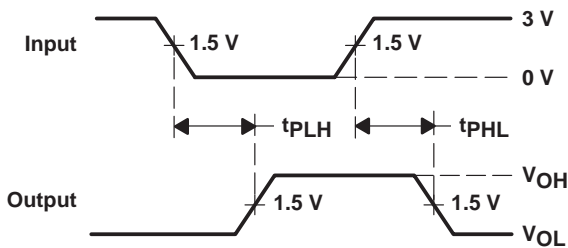

**VOLTAGE WAVEFORMS  
PROPAGATION DELAY TIMES  
INVERTING AND NONINVERTING OUTPUTS**

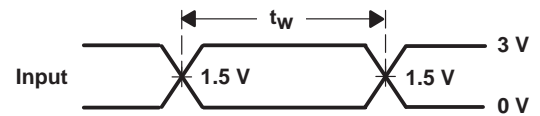

**VOLTAGE WAVEFORMS  
PULSE DURATION**

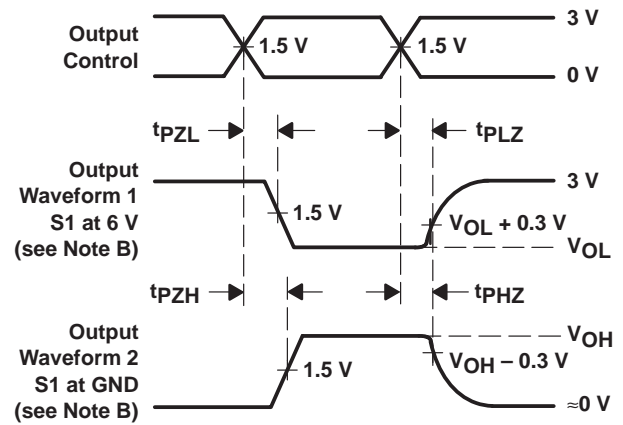

**VOLTAGE WAVEFORMS  
ENABLE AND DISABLE TIMES  
LOW- AND HIGH-LEVEL ENABLING**

- NOTES:
- $C_L$  includes probe and jig capacitance.
  - Waveform 1 is for an output with internal conditions such that the output is low except when disabled by the output control. Waveform 2 is for an output with internal conditions such that the output is high except when disabled by the output control.
  - All input pulses are supplied by generators having the following characteristics:  $PRR \leq 10\text{ MHz}$ ,  $Z_O = 50\ \Omega$ ,  $t_r \leq 2.5\text{ ns}$ ,  $t_f \leq 2.5\text{ ns}$ .
  - The outputs are measured one at a time with one transition per measurement.

**Figure 2. Load Circuit and Voltage Waveforms**

**PACKAGING INFORMATION**

Orderable Device	Status (1)	Package Type	Package Drawing	Pins	Package Qty	Eco Plan (2)	Lead/Ball Finish	MSL Peak Temp (3)	Op Temp (°C)	Top-Side Markings (4)	Samples
74ALVTH32374ZKER	ACTIVE	LFBGA	ZKE	96	1000	Green (RoHS & no Sb/Br)	SNAGCU	Level-3-260C-168 HR	-40 to 85	VL374	<a href="#">Samples</a>
SN74ALVTH32374KR	NRND	LFBGA	GKE	96	1000	TBD	SNPB	Level-2-235C-1 YEAR	-40 to 85	VL374	

(1) The marketing status values are defined as follows:

**ACTIVE:** Product device recommended for new designs.

**LIFEBUY:** TI has announced that the device will be discontinued, and a lifetime-buy period is in effect.

**NRND:** Not recommended for new designs. Device is in production to support existing customers, but TI does not recommend using this part in a new design.

**PREVIEW:** Device has been announced but is not in production. Samples may or may not be available.

**OBSOLETE:** TI has discontinued the production of the device.

(2) Eco Plan - The planned eco-friendly classification: Pb-Free (RoHS), Pb-Free (RoHS Exempt), or Green (RoHS & no Sb/Br) - please check <http://www.ti.com/productcontent> for the latest availability information and additional product content details.

**TBD:** The Pb-Free/Green conversion plan has not been defined.

**Pb-Free (RoHS):** TI's terms "Lead-Free" or "Pb-Free" mean semiconductor products that are compatible with the current RoHS requirements for all 6 substances, including the requirement that lead not exceed 0.1% by weight in homogeneous materials. Where designed to be soldered at high temperatures, TI Pb-Free products are suitable for use in specified lead-free processes.

**Pb-Free (RoHS Exempt):** This component has a RoHS exemption for either 1) lead-based flip-chip solder bumps used between the die and package, or 2) lead-based die adhesive used between the die and leadframe. The component is otherwise considered Pb-Free (RoHS compatible) as defined above.

**Green (RoHS & no Sb/Br):** TI defines "Green" to mean Pb-Free (RoHS compatible), and free of Bromine (Br) and Antimony (Sb) based flame retardants (Br or Sb do not exceed 0.1% by weight in homogeneous material)

(3) MSL, Peak Temp. -- The Moisture Sensitivity Level rating according to the JEDEC industry standard classifications, and peak solder temperature.

(4) Multiple Top-Side Markings will be inside parentheses. Only one Top-Side Marking contained in parentheses and separated by a "~" will appear on a device. If a line is indented then it is a continuation of the previous line and the two combined represent the entire Top-Side Marking for that device.

**Important Information and Disclaimer:**The information provided on this page represents TI's knowledge and belief as of the date that it is provided. TI bases its knowledge and belief on information provided by third parties, and makes no representation or warranty as to the accuracy of such information. Efforts are underway to better integrate information from third parties. TI has taken and continues to take reasonable steps to provide representative and accurate information but may not have conducted destructive testing or chemical analysis on incoming materials and chemicals. TI and TI suppliers consider certain information to be proprietary, and thus CAS numbers and other limited information may not be available for release.

In no event shall TI's liability arising out of such information exceed the total purchase price of the TI part(s) at issue in this document sold by TI to Customer on an annual basis.

**TAPE AND REEL INFORMATION**

**QUADRANT ASSIGNMENTS FOR PIN 1 ORIENTATION IN TAPE**

\*All dimensions are nominal

Device	Package Type	Package Drawing	Pins	SPQ	Reel Diameter (mm)	Reel Width W1 (mm)	A0 (mm)	B0 (mm)	K0 (mm)	P1 (mm)	W (mm)	Pin1 Quadrant
74ALVTH32374ZKER	LFBGA	ZKE	96	1000	330.0	24.4	5.7	13.7	2.0	8.0	24.0	Q1
SN74ALVTH32374KR	LFBGA	GKE	96	1000	330.0	24.4	5.7	13.7	2.0	8.0	24.0	Q1

**TAPE AND REEL BOX DIMENSIONS**

\*All dimensions are nominal

Device	Package Type	Package Drawing	Pins	SPQ	Length (mm)	Width (mm)	Height (mm)
74ALVTH32374ZKER	LFBGA	ZKE	96	1000	336.6	336.6	41.3
SN74ALVTH32374KR	LFBGA	GKE	96	1000	336.6	336.6	41.3

GKE (R-PBGA-N96)

PLASTIC BALL GRID ARRAY

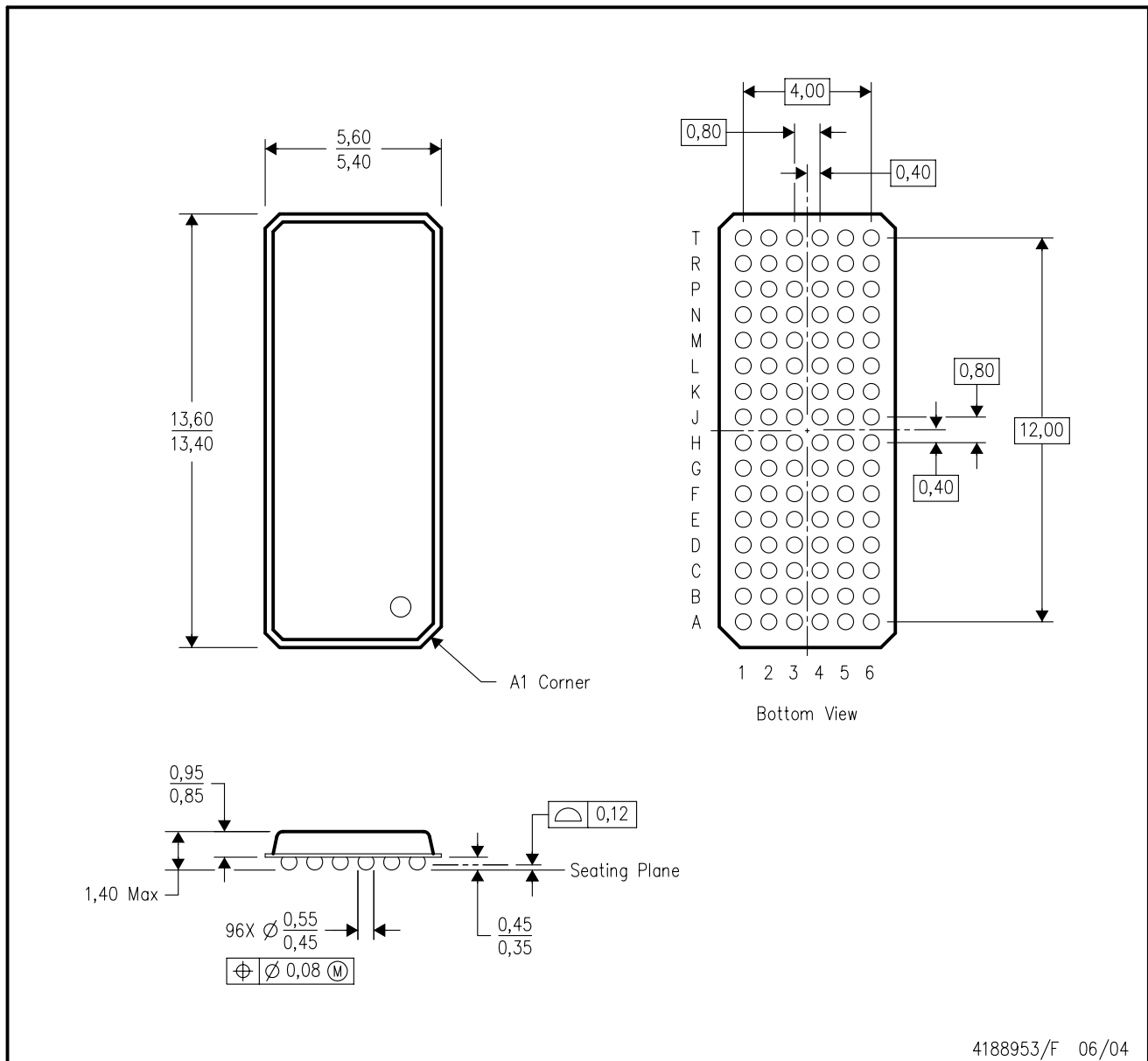

4188953/F 06/04

- NOTES:
- A. All linear dimensions are in millimeters.
  - B. This drawing is subject to change without notice.
  - C. Falls within JEDEC MO-205 variation CC.
  - D. This package is tin-lead (SnPb). Refer to the 96 ZKE package (drawing 4204493) for lead-free.

ZKE (R-PBGA-N96)

PLASTIC BALL GRID ARRAY

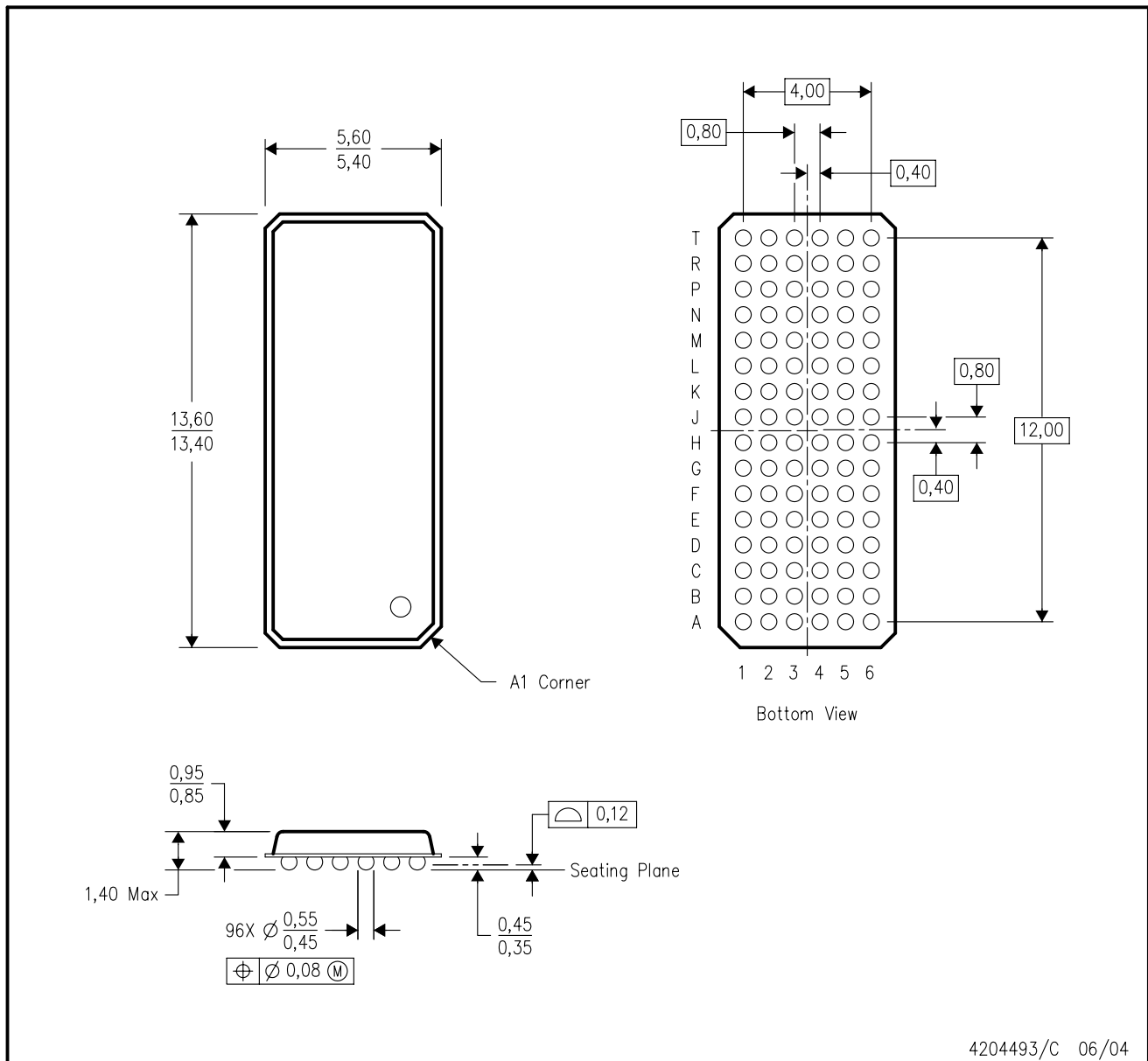

- NOTES:
- A. All linear dimensions are in millimeters.
  - B. This drawing is subject to change without notice.
  - C. Falls within JEDEC MO-205 variation CC.
  - D. This package is lead-free. Refer to the 96 GKE package (drawing 4188953) for tin-lead (SnPb).

## IMPORTANT NOTICE

Texas Instruments Incorporated and its subsidiaries (TI) reserve the right to make corrections, enhancements, improvements and other changes to its semiconductor products and services per JESD46, latest issue, and to discontinue any product or service per JESD48, latest issue. Buyers should obtain the latest relevant information before placing orders and should verify that such information is current and complete. All semiconductor products (also referred to herein as "components") are sold subject to TI's terms and conditions of sale supplied at the time of order acknowledgment.

TI warrants performance of its components to the specifications applicable at the time of sale, in accordance with the warranty in TI's terms and conditions of sale of semiconductor products. Testing and other quality control techniques are used to the extent TI deems necessary to support this warranty. Except where mandated by applicable law, testing of all parameters of each component is not necessarily performed.

TI assumes no liability for applications assistance or the design of Buyers' products. Buyers are responsible for their products and applications using TI components. To minimize the risks associated with Buyers' products and applications, Buyers should provide adequate design and operating safeguards.

TI does not warrant or represent that any license, either express or implied, is granted under any patent right, copyright, mask work right, or other intellectual property right relating to any combination, machine, or process in which TI components or services are used. Information published by TI regarding third-party products or services does not constitute a license to use such products or services or a warranty or endorsement thereof. Use of such information may require a license from a third party under the patents or other intellectual property of the third party, or a license from TI under the patents or other intellectual property of TI.

Reproduction of significant portions of TI information in TI data books or data sheets is permissible only if reproduction is without alteration and is accompanied by all associated warranties, conditions, limitations, and notices. TI is not responsible or liable for such altered documentation. Information of third parties may be subject to additional restrictions.

Resale of TI components or services with statements different from or beyond the parameters stated by TI for that component or service voids all express and any implied warranties for the associated TI component or service and is an unfair and deceptive business practice. TI is not responsible or liable for any such statements.

Buyer acknowledges and agrees that it is solely responsible for compliance with all legal, regulatory and safety-related requirements concerning its products, and any use of TI components in its applications, notwithstanding any applications-related information or support that may be provided by TI. Buyer represents and agrees that it has all the necessary expertise to create and implement safeguards which anticipate dangerous consequences of failures, monitor failures and their consequences, lessen the likelihood of failures that might cause harm and take appropriate remedial actions. Buyer will fully indemnify TI and its representatives against any damages arising out of the use of any TI components in safety-critical applications.

In some cases, TI components may be promoted specifically to facilitate safety-related applications. With such components, TI's goal is to help enable customers to design and create their own end-product solutions that meet applicable functional safety standards and requirements. Nonetheless, such components are subject to these terms.

No TI components are authorized for use in FDA Class III (or similar life-critical medical equipment) unless authorized officers of the parties have executed a special agreement specifically governing such use.

Only those TI components which TI has specifically designated as military grade or "enhanced plastic" are designed and intended for use in military/aerospace applications or environments. Buyer acknowledges and agrees that any military or aerospace use of TI components which have **not** been so designated is solely at the Buyer's risk, and that Buyer is solely responsible for compliance with all legal and regulatory requirements in connection with such use.

TI has specifically designated certain components as meeting ISO/TS16949 requirements, mainly for automotive use. In any case of use of non-designated products, TI will not be responsible for any failure to meet ISO/TS16949.

### Products

Audio	<a href="http://www.ti.com/audio">www.ti.com/audio</a>
Amplifiers	<a href="http://amplifier.ti.com">amplifier.ti.com</a>
Data Converters	<a href="http://dataconverter.ti.com">dataconverter.ti.com</a>
DLP® Products	<a href="http://www.dlp.com">www.dlp.com</a>
DSP	<a href="http://dsp.ti.com">dsp.ti.com</a>
Clocks and Timers	<a href="http://www.ti.com/clocks">www.ti.com/clocks</a>
Interface	<a href="http://interface.ti.com">interface.ti.com</a>
Logic	<a href="http://logic.ti.com">logic.ti.com</a>
Power Mgmt	<a href="http://power.ti.com">power.ti.com</a>
Microcontrollers	<a href="http://microcontroller.ti.com">microcontroller.ti.com</a>
RFID	<a href="http://www.ti-rfid.com">www.ti-rfid.com</a>
OMAP Applications Processors	<a href="http://www.ti.com/omap">www.ti.com/omap</a>
Wireless Connectivity	<a href="http://www.ti.com/wirelessconnectivity">www.ti.com/wirelessconnectivity</a>

### Applications

Automotive and Transportation	<a href="http://www.ti.com/automotive">www.ti.com/automotive</a>
Communications and Telecom	<a href="http://www.ti.com/communications">www.ti.com/communications</a>
Computers and Peripherals	<a href="http://www.ti.com/computers">www.ti.com/computers</a>
Consumer Electronics	<a href="http://www.ti.com/consumer-apps">www.ti.com/consumer-apps</a>
Energy and Lighting	<a href="http://www.ti.com/energy">www.ti.com/energy</a>
Industrial	<a href="http://www.ti.com/industrial">www.ti.com/industrial</a>
Medical	<a href="http://www.ti.com/medical">www.ti.com/medical</a>
Security	<a href="http://www.ti.com/security">www.ti.com/security</a>
Space, Avionics and Defense	<a href="http://www.ti.com/space-avionics-defense">www.ti.com/space-avionics-defense</a>
Video and Imaging	<a href="http://www.ti.com/video">www.ti.com/video</a>

### TI E2E Community

[e2e.ti.com](http://e2e.ti.com)

## Looking for pricing, stock, or lifecycle information?

Click below to explore more details on WIN SOURCE:

 [View SN74ALVTH32374KR on WIN SOURCE](#)

 [Texas Instruments](#) Information

## Optimize Your Supply Chain with WIN SOURCE Solutions

-  Global Sourcing Solution
-  Obsolete Management
-  Cost Control Management
-  Shortage Management
-  Alternative Solution
-  Excess Inventory Management