



**THE DATASHEET OF
MC10H600FNR2**



MC10H600, MC100H600

9-Bit TTL to ECL Translator

Description

The MC10H/100H600 is a 9-bit, dual supply TTL to ECL translator. Devices in the ON Semiconductor 9-bit translator series utilize the PLCC-28 for optimal power pinning, signal flow-through and electrical performance.

The H600 features both ECL and TTL logic enable controls for maximum flexibility.

The 10H version is compatible with MECL 10H ECL logic levels. The 100H version is compatible with 100K levels.

Features

- 9-Bit Ideal for Byte-Parity Applications
- Flow-Through Configuration
- Extra TTL and ECL Power/Ground Pins to Minimize Switching Noise
- ECL and TTL Enable Inputs
- Dual Supply
- 3.5 ns Max D to Q
- PNP TTL Inputs for Low Loading
- Choice of ECL Compatibility:
MECL 10H (10Hxxx) or 100K (100Hxxx)
- Pb-Free Packages are Available*



ON Semiconductor®

<http://onsemi.com>

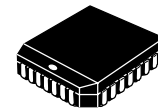

PLCC-28
FN SUFFIX
CASE 776

MARKING DIAGRAM*

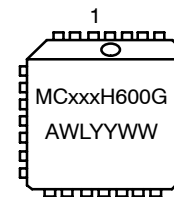

xxx = 10 or 100
A = Assembly Location
WL = Wafer Lot
YY = Year
WW = Work Week
G = Pb-Free Package

*For additional marking information, refer to Application Note AND8002/D.

ORDERING INFORMATION

See detailed ordering and shipping information in the package dimensions section on page 4 of this data sheet.

*For additional information on our Pb-Free strategy and soldering details, please download the ON Semiconductor Soldering and Mounting Techniques Reference Manual, SOLDERRM/D.

MC10H600, MC100H600

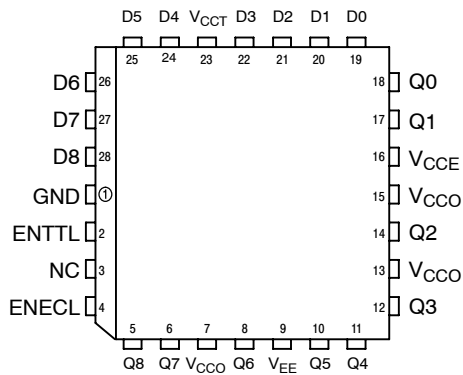

Figure 1. Pinout: PLCC-28 (Top View)

Table 1. PIN NAMES

PIN	FUNCTION
GND	TTL Ground (0 V)
V _{CCE}	ECL V _{CC} (0 V)
V _{CCO}	ECL V _{CC} (0 V) – Outputs
V _{CCT}	TTL Supply (+5.0 V)
V _{EE}	ECL Supply (-5.2/-4.5 V)
D0–D8	Data Inputs (TTL)
Q0–Q8	Data Outputs (ECL)
ENECL	Enable Control (ECL)
ENTTL	Enable Control (TTL)

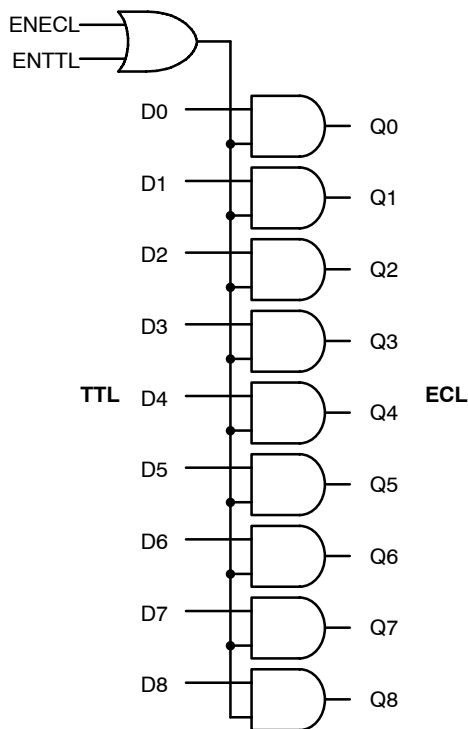

Figure 2. Logic Symbol

Table 2. TRUTH TABLE

ENECL	ENTTL	D	Q
H	X	H	H
H	X	L	L
X	H	H	H
X	H	L	L
L	L	X	L

Table 3. DC CHARACTERISTICS: V_{CCT} = 5.0 V ± 10%; V_{EE} = -5.2 V ± 5% (10H version); V_{EE} = -4.2 V to -5.5 V (100H)

Symbol	Parameter	0°C		25°C		75°C		Unit
		Min	Max	Min	Max	Min	Max	
Power Supply Current								
I _{EE}	ECL							
		10H	-125		-125		-125	mA
		100H	-122		-123		-132	
I _{CCH}	TTL		48		48		48	mA
I _{CCL}			50		50		50	

NOTE: Device will meet the specifications after thermal equilibrium has been established when mounted in a test socket or printed circuit board with maintained transverse airflow greater than 500 lfm. Electrical parameters are guaranteed only over the declared operating temperature range. Functional operation of the device exceeding these conditions is not implied. Device specification limit values are applied individually under normal operating conditions and not valid simultaneously.

MC10H600, MC100H600

Table 4. 10H ECL DC CHARACTERISTICS: $V_{CCT} = 5.0\text{ V} \pm 10\%$; $V_{EE} = -5.2\text{ V} \pm 5\%$

Symbol	Parameter	Condition	0°C		25°C		75°C		Unit
			Min	Max	Min	Max	Min	Max	
I_{INH} I_{IL}	Input HIGH Current Input LOW Current		0.5	225	0.5	175	0.5	175	μA μA
V_{IH} V_{IL}	Input HIGH Voltage Input LOW Voltage		-1170 -1950	-840 -1480	-1130 -1950	-810 -1480	-1070 -1950	-735 -1450	mV
V_{OH} V_{OL}	Output HIGH Voltage Output LOW Voltage	50 Ω to -2.0 V	-1020 -1950	-840 -1630	-980 -1950	-810 -1630	-920 -1950	-735 -1600	mV

NOTE: Device will meet the specifications after thermal equilibrium has been established when mounted in a test socket or printed circuit board with maintained transverse airflow greater than 500 lfm. Electrical parameters are guaranteed only over the declared operating temperature range. Functional operation of the device exceeding these conditions is not implied. Device specification limit values are applied individually under normal operating conditions and not valid simultaneously.

Table 5. 100H ECL DC CHARACTERISTICS: $V_{CCT} = 5.0\text{ V} \pm 10\%$; $V_{EE} = -4.2\text{ V}$ to -5.5 V

Symbol	Parameter	Condition	0°C		25°C		75°C		Unit
			Min	Max	Min	Max	Min	Max	
I_{INH} I_{IL}	Input HIGH Current Input LOW Current		0.5	255	0.5	175	0.5	175	μA μA
V_{IH} V_{IL}	Input HIGH Voltage Input LOW Voltage		-1165 -1810	-880 -1475	-1165 -1810	-880 -1475	-1165 -1810	-880 -1475	mV
V_{OH} V_{OL}	Output HIGH Voltage Output LOW Voltage	50 Ω to -2.0 V	-1025 -1810	-880 -1620	-1025 -1810	-880 -1620	-1025 -1810	-880 -1620	mV

NOTE: Device will meet the specifications after thermal equilibrium has been established when mounted in a test socket or printed circuit board with maintained transverse airflow greater than 500 lfm. Electrical parameters are guaranteed only over the declared operating temperature range. Functional operation of the device exceeding these conditions is not implied. Device specification limit values are applied individually under normal operating conditions and not valid simultaneously.

Table 6. TTL DC CHARACTERISTICS: $V_{CCT} = 5.0\text{ V} \pm 10\%$; $V_{EE} = -5.2\text{ V} \pm 5\%$ (10H); $V_{EE} = -4.2\text{ V}$ to -5.5 V (100H)

Symbol	Parameter	Condition	0°C		25°C		75°C		Unit
			Min	Max	Min	Max	Min	Max	
V_{IH} V_{IL}	Input HIGH Voltage Input LOW Voltage		2.0	0.8	2.0	0.8	2.0	0.8	V V
I_{IH}	Input HIGH Current	$V_{IN} = 2.7\text{ V}$ $V_{IN} = 7.0\text{ V}$		20 100		20 100		20 100	μA
I_{IL}	Input LOW Current	$V_{IN} = 0.5\text{ V}$		-0.6		-0.6		-0.6	mA
V_{IK}	Input Clamp Voltage	$I_{IN} = -18\text{ mA}$		-1.2		-1.2		-1.2	V

NOTE: Device will meet the specifications after thermal equilibrium has been established when mounted in a test socket or printed circuit board with maintained transverse airflow greater than 500 lfm. Electrical parameters are guaranteed only over the declared operating temperature range. Functional operation of the device exceeding these conditions is not implied. Device specification limit values are applied individually under normal operating conditions and not valid simultaneously.

MC10H600, MC100H600

Table 7. AC CHARACTERISTICS: $V_{CCT} = 5.0\text{ V} \pm 10\%$; $V_{EE} = -5.2\text{ V} \pm 5\%$ (10H); $V_{EE} = -4.2\text{ V}$ to -5.5 V (100H)

Symbol	Parameter		Condition	0°C		25°C		75°C		Unit
				Min	Max	Min	Max	Min	Max	
t_{PLH} t_{PHL}	Propagation Delay to Output	D	50 Ω to -2.0 V	1.4	3.0	1.5	3.2	1.7	3.5	ns
		ENECL/ ENTTL		1.8	3.7	1.9	3.9	2.0	4.1	ns
t_R t_F	Output Rise/Fall Time 20% - 80%			0.5	1.5	0.5	1.5	0.5	1.5	ns

NOTE: Device will meet the specifications after thermal equilibrium has been established when mounted in a test socket or printed circuit board with maintained transverse airflow greater than 500 lfm. Electrical parameters are guaranteed only over the declared operating temperature range. Functional operation of the device exceeding these conditions is not implied. Device specification limit values are applied individually under normal operating conditions and not valid simultaneously.

ORDERING INFORMATION

Device	Package	Shipping [†]
MC10H600FN	PLCC-28	37 Units / Rail
MC10H600FNG	PLCC-28 (Pb-Free)	37 Units / Rail
MC10H600FNR2	PLCC-28	500 / Tape & Reel
MC10H600FNR2G	PLCC-28 (Pb-Free)	500 / Tape & Reel
MC100H600FN	PLCC-28	37 Units / Rail
MC100H600FNG	PLCC-28 (Pb-Free)	37 Units / Rail
MC100H600FNR2	PLCC-28	500 / Tape & Reel
MC100H600FNR2G	PLCC-28 (Pb-Free)	500 / Tape & Reel

[†]For information on tape and reel specifications, including part orientation and tape sizes, please refer to our Tape and Reel Packaging Specifications Brochure, BRD8011/D.

Resource Reference of Application Notes

- AN1405/D** - ECL Clock Distribution Techniques
- AN1406/D** - Designing with PECL (ECL at +5.0 V)
- AN1503/D** - ECLinPS™ I/O SPICE Modeling Kit
- AN1504/D** - Metastability and the ECLinPS Family
- AN1568/D** - Interfacing Between LVDS and ECL
- AN1672/D** - The ECL Translator Guide
- AND8001/D** - Odd Number Counters Design
- AND8002/D** - Marking and Date Codes
- AND8020/D** - Termination of ECL Logic Devices
- AND8066/D** - Interfacing with ECLinPS
- AND8090/D** - AC Characteristics of ECL Devices

MC10H600, MC100H600

PACKAGE DIMENSIONS

PLCC-28
FN SUFFIX
PLASTIC PLCC PACKAGE
CASE 776-02
ISSUE E

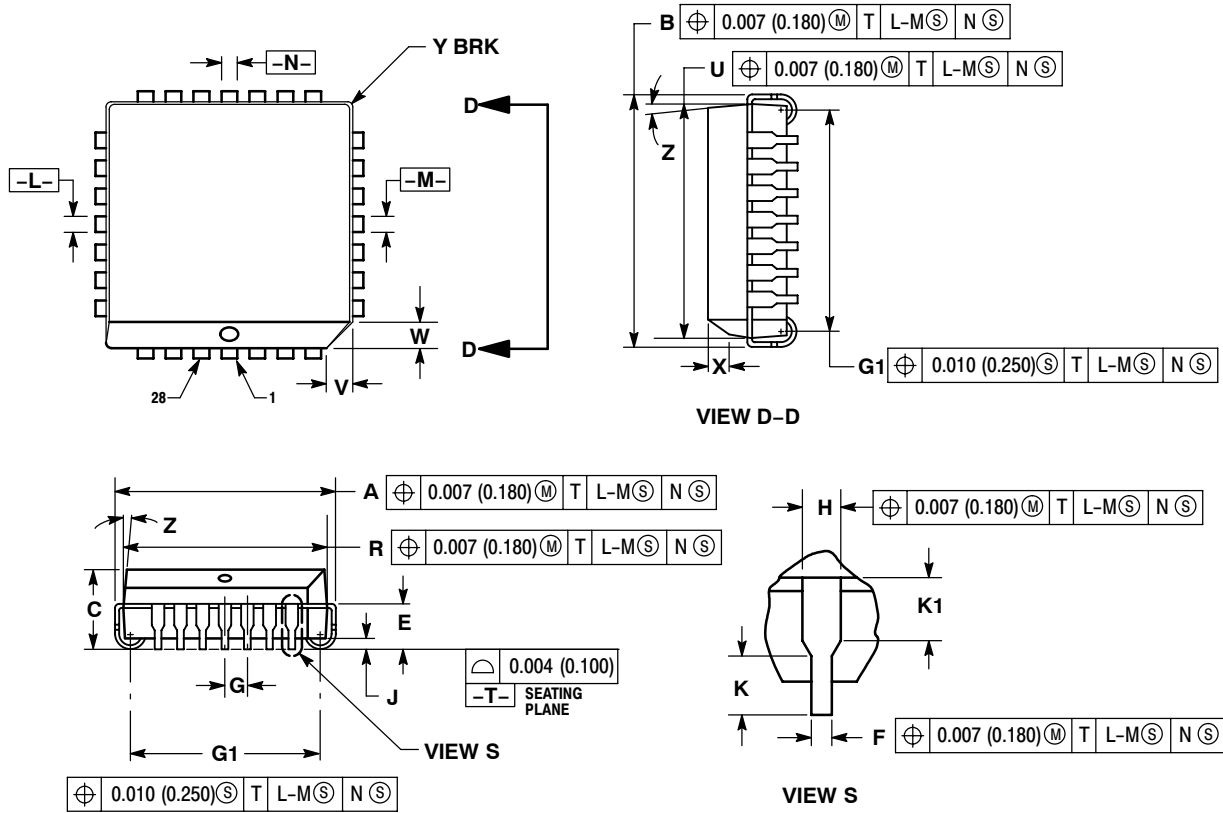

NOTES:

- DATUMS -L-, -M-, AND -N- DETERMINED WHERE TOP OF LEAD SHOULDER EXITS PLASTIC BODY AT MOLD PARTING LINE.
- DIMENSION G1, TRUE POSITION TO BE MEASURED AT DATUM -T-, SEATING PLANE.
- DIMENSIONS R AND U DO NOT INCLUDE MOLD FLASH. ALLOWABLE MOLD FLASH IS 0.010 (0.250) PER SIDE.
- DIMENSIONING AND TOLERANCING PER ANSI Y14.5M, 1982.
- CONTROLLING DIMENSION: INCH.
- THE PACKAGE BOTTOM MAY BE SMALLER THAN THE PACKAGE TOP BY UP TO 0.012 (0.300). DIMENSIONS R AND U ARE DETERMINED AT THE OUTERMOST EXTREMES OF THE PLASTIC BODY EXCLUSIVE OF MOLD FLASH, TIE BAR BURRS, GATE BURRS AND INTERLEAD FLASH, BUT INCLUDING ANY MISMATCH BETWEEN THE TOP AND BOTTOM OF THE PLASTIC BODY.
- DIMENSION H DOES NOT INCLUDE DAMBAR PROTRUSION OR INTRUSION. THE DAMBAR PROTRUSION(S) SHALL NOT CAUSE THE H DIMENSION TO BE GREATER THAN 0.037 (0.940). THE DAMBAR INTRUSION(S) SHALL NOT CAUSE THE H DIMENSION TO BE SMALLER THAN 0.025 (0.635).

DIM	INCHES		MILLIMETERS	
	MIN	MAX	MIN	MAX
A	0.485	0.495	12.32	12.57
B	0.485	0.495	12.32	12.57
C	0.165	0.180	4.20	4.57
E	0.090	0.110	2.29	2.79
F	0.013	0.019	0.33	0.48
G	0.050 BSC		1.27 BSC	
H	0.026	0.032	0.66	0.81
J	0.020	---	0.51	---
K	0.025	---	0.64	---
R	0.450	0.456	11.43	11.58
U	0.450	0.456	11.43	11.58
V	0.042	0.048	1.07	1.21
W	0.042	0.048	1.07	1.21
X	0.042	0.056	1.07	1.42
Y	---	0.020	---	0.50
Z	2° 10°		2° 10°	
G1	0.410	0.430	10.42	10.92
K1	0.040	---	1.02	---

MC10H600, MC100H600

ECLinPS is a trademark of Semiconductor Components Industries, LLC (SCILLC).

ON Semiconductor and **ON** are registered trademarks of Semiconductor Components Industries, LLC (SCILLC). SCILLC reserves the right to make changes without further notice to any products herein. SCILLC makes no warranty, representation or guarantee regarding the suitability of its products for any particular purpose, nor does SCILLC assume any liability arising out of the application or use of any product or circuit, and specifically disclaims any and all liability, including without limitation special, consequential or incidental damages. "Typical" parameters which may be provided in SCILLC data sheets and/or specifications can and do vary in different applications and actual performance may vary over time. All operating parameters, including "Typicals" must be validated for each customer application by customer's technical experts. SCILLC does not convey any license under its patent rights nor the rights of others. SCILLC products are not designed, intended, or authorized for use as components in systems intended for surgical implant into the body, or other applications intended to support or sustain life, or for any other application in which the failure of the SCILLC product could create a situation where personal injury or death may occur. Should Buyer purchase or use SCILLC products for any such unintended or unauthorized application, Buyer shall indemnify and hold SCILLC and its officers, employees, subsidiaries, affiliates, and distributors harmless against all claims, costs, damages, and expenses, and reasonable attorney fees arising out of, directly or indirectly, any claim of personal injury or death associated with such unintended or unauthorized use, even if such claim alleges that SCILLC was negligent regarding the design or manufacture of the part. SCILLC is an Equal Opportunity/Affirmative Action Employer. This literature is subject to all applicable copyright laws and is not for resale in any manner.

PUBLICATION ORDERING INFORMATION

LITERATURE FULFILLMENT:

Literature Distribution Center for ON Semiconductor
P.O. Box 5163, Denver, Colorado 80217 USA
Phone: 303-675-2175 or 800-344-3860 Toll Free USA/Canada
Fax: 303-675-2176 or 800-344-3867 Toll Free USA/Canada
Email: orderlit@onsemi.com

N. American Technical Support: 800-282-9855 Toll Free
USA/Canada
Europe, Middle East and Africa Technical Support:
Phone: 421 33 790 2910
Japan Customer Focus Center
Phone: 81-3-5773-3850

ON Semiconductor Website: www.onsemi.com
Order Literature: <http://www.onsemi.com/orderlit>

For additional information, please contact your local
Sales Representative

Looking for pricing, stock, or lifecycle information?

Click below to explore more details on WIN SOURCE:

 [View MC10H600FNR2 on WIN SOURCE](#)

 [ON Semiconductor](#) Information

Optimize Your Supply Chain with WIN SOURCE Solutions

-  Global Sourcing Solution
-  Obsolete Management
-  Cost Control Management
-  Shortage Management
-  Alternative Solution
-  Excess Inventory Management