



**THE DATASHEET OF
D2SW-P01L3D**



D2SW-P

Sealed Subminiature Basic Switch

Sealed Basic Switch with Simplified Construction, Mounting Compatible with SS and D2SW Series.

- Rubber packing construction keeps dust off and offers temporary waterproofing protection (IEC IP67).
- Switch rating of 2 A at 250 VAC possible with a single-leaf movable spring. Models for micro loads are also available.
- Solder, quick-connect terminals (#110), PCB terminals, and molded lead wires are available.
- UL, CSA, VDE safety standard approved models are available upon request.

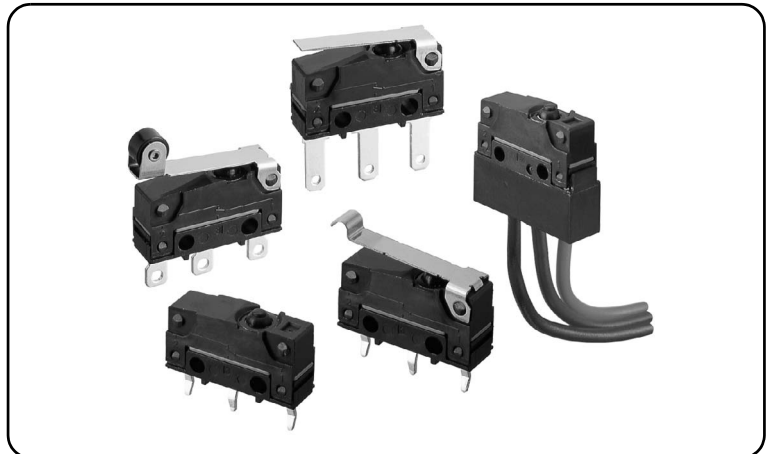

D2SW-P

RoHS Compliant

Model Number Legend

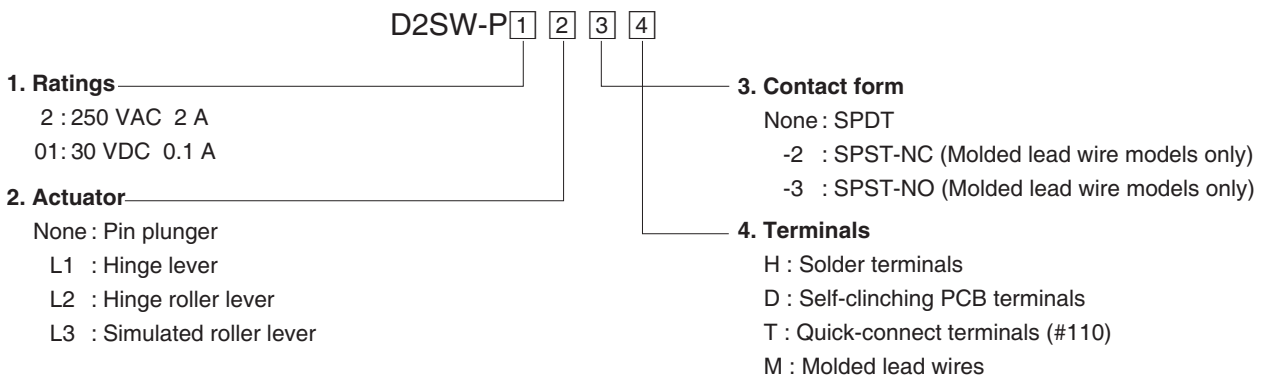

List of Models (Contact your dealer for detailed delivery date.)

Actuator	Terminals	Ratings Contact Form	2 A	0.1 A
Pin plunger	Solder terminals	SPDT	D2SW-P2H	D2SW-P01H
	Quick-connect terminals (#110)		D2SW-P2T	D2SW-P01T
	PCB terminals		D2SW-P2D	D2SW-P01D
	Molded lead wires	SPDT	D2SW-P2M	D2SW-P01M
		SPST-NC	D2SW-P2-2M	D2SW-P01-2M
	SPST-NO	D2SW-P2-3M	D2SW-P01-3M	
Hinge lever	Solder terminals	SPDT	D2SW-P2L1H	D2SW-P01L1H
	Quick-connect terminals (#110)		D2SW-P2L1T	D2SW-P01L1T
	PCB terminals		D2SW-P2L1D	D2SW-P01L1D
	Molded lead wires		D2SW-P2L1M	D2SW-P01L1M
Hinge roller lever	Solder terminals	SPDT	D2SW-P2L2H	D2SW-P01L2H
	Quick-connect terminals (#110)		D2SW-P2L2T	D2SW-P01L2T
	PCB terminals		D2SW-P2L2D	D2SW-P01L2D
	Molded lead wires		D2SW-P2L2M	D2SW-P01L2M
Simulated roller lever	Solder terminals	SPDT	D2SW-P2L3H	D2SW-P01L3H
	Quick-connect terminals (#110)		D2SW-P2L3T	D2SW-P01L3T
	PCB terminals		D2SW-P2L3D	D2SW-P01L3D
	Molded lead wires		D2SW-P2L3M	D2SW-P01L3M

Separator (Sold Separately), Terminal Connector (Sold Separately) ➔ Refer to "Micro Switch Common Accessories"

Contact Form

● SPDT

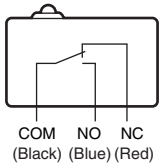

● SPST-NC (Molded lead wire models only)

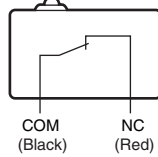

● SPST-NO (Molded lead wire models only)

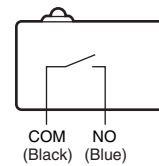

The color in parentheses indicates the color of the lead wire.

Contact Specifications

Item	Model	D2SW-P2 models	D2SW-P01 models
Contact	Specification	Rivet	Crossbar
	Material	Silver	Gold alloy
	Gap (Standard value)	0.5 mm	
Minimum applicable load (reference value)*		160 mA at 5 VDC	1 mA at 5 VDC

* Please refer to "●Using Micro Loads" in "Precautions" for more information on the minimum applicable load.

Ratings

Model	Rated voltage	Resistive load
D2SW-P2 models	250 VAC	2 A
	30 VDC	
D2SW-P01 models	125 VAC	0.1 A
	30 VDC	

Note. The above rating values apply under the following test conditions.

- (1) Ambient temperature: 20±2°C
- (2) Ambient humidity: 65±5%
- (3) Operating frequency: 20 operations/min

Approved Safety Standards

The items shown in the "List of Models" are not standard approved models.

Consult your OMRON sales representative for specific models with standard approvals.

UL (UL1054/CSA C22.2 No.55)

Rated voltage	Model	D2SW-P2	D2SW-P01
125 VAC		-	0.1 A
250 VAC		2 A	-
30 VDC		2 A	0.1 A

VDE (EN61058-1)

Rated voltage	Model	D2SW-P2	D2SW-P01
125 VAC		-	0.1 A
250 VAC		2 A	-
30 VDC		2 A	0.1 A

Testing conditions: 5E4 (50,000 operations) T55 (0°C to 55°C)

Characteristics

Item	Model	D2SW-P2 models	D2SW-P01 models
Permissible operating speed		0.1 mm to 500 mm/s (for pin plunger models)	
Permissible operating frequency	Mechanical	120 operations/min	
	Electrical	30 operations/min	
Insulation resistance		100 mΩ min. (500 VDC with insulation tester)	
Contact resistance (initial value)	Terminal models	50 mΩ max.	100 mΩ max.
	Molded lead wire models	100 mΩ max.	150 mΩ max.
Dielectric strength *1	Between terminals of the same polarity	1,000 VAC 50/60 Hz for 1 min	600 VAC 50/60 Hz for 1 min
	Between current-carrying metal parts and ground	1,500 VAC 50/60 Hz for 1 min	
	Between each terminals and non-current-carrying metal parts	1,500 VAC 50/60 Hz for 1 min	
Vibration resistance *2	Malfunction	10 to 55 Hz, 1.5-mm double amplitude	
Shock resistance	Destruction	1,000 m/s ² {approx. 100G} max.	
	Malfunction *2	300 m/s ² {approx. 30G} max.	
Durability *3	Mechanical	1,000,000 operations min. (60 operations/min)	
	Electrical	50,000 operations min. (20 operations/min)	200,000 operations min. (20 operations/min)
Degree of protection	Terminal models	IEC IP67 (excluding the terminals on terminal models)	
	Molded lead wire models	IEC IP67	
Degree of protection against electric shock		Class I	
Proof tracking index (PTI)		250	
Ambient operating temperature		-20°C to +70°C (at ambient humidity of 60% max.) (with no icing or condensation)	
Ambient operating humidity		85% max. (for +5 to +35°C)	
Weight		Approx. 2 g (for pin plunger models with terminals)	

Note. The data given above are initial values.

*1. The dielectric strength shown in the table indicates values for models with a Separator.

*2. The values are at Free Position and Total Travel Position values for pin plunger, and Total Travel Position value for lever. Close or open circuit of contact is 1 ms max.

*3. For testing conditions, consult your OMRON sales representative.

Terminals and Shapes (Unit: mm)

●Solder terminals

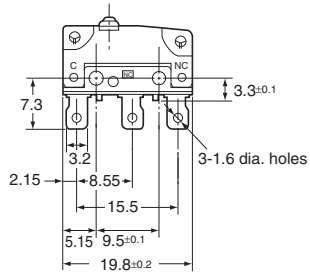

●Quick-connect terminals (#110)

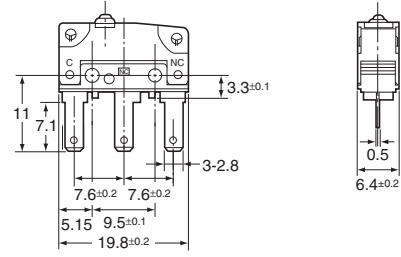

●PCB terminals

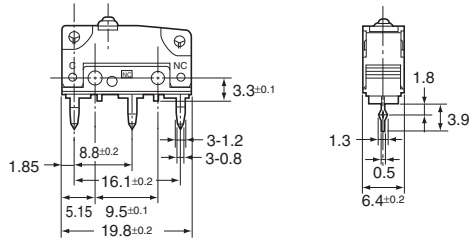

●Molded lead wires

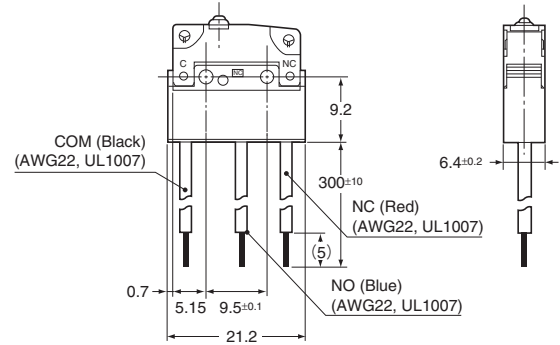

<PCB Mounting Dimensions (Reference)>

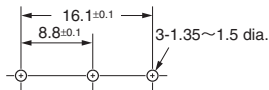

Mounting Holes (Unit: mm)

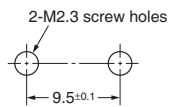

Dimensions (Unit: mm) / Operating Characteristics

The illustrations and drawings are for solder terminal models.

Refer to "Terminals and Shapes" of previous page for details on models with quick-connect terminals (#110) or PCB terminals or molded lead wires.

The □ in the model number is for the contact form code or the terminal code. See the "List of Models" for available combinations of models.

●Pin Plunger Models

D2SW-P2□□

D2SW-P01□□

D
2
S
W
P

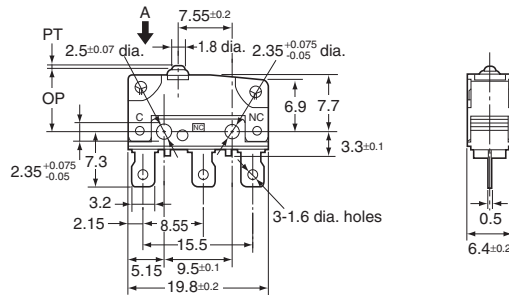

Operating characteristics		Model	D2SW-P2□□ D2SW-P01□□
Operating Force	OF	Max.	1.8 N {184 gf}
Releasing Force	RF	Min.	0.2 N {20 gf}
Pretravel	PT	Max.	0.6 mm
Overtravel	OT	Min.	0.4 mm
Movement Differential	MD	Max.	0.15 mm
Operating Position	OP		8.4±0.3mm

●Hinge Lever Models

D2SW-P2L1□□

D2SW-P01L1□□

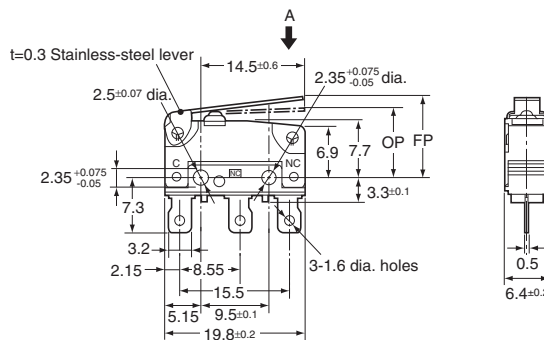
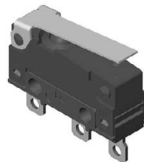

Operating characteristics		Model	D2SW-P2L1□□ D2SW-P01L1□□
Operating Force	OF	Max.	0.6 N {61 gf}
Releasing Force	RF	Min.	0.05 N {5 gf}
Overtravel	OT	Min.	0.8 mm
Movement Differential	MD	Max.	0.8 mm
Free Position	FP	Max.	13.6 mm
Operating Position	OP		8.8±0.8 mm

●Hinge Roller Lever Models

D2SW-P2L2□□

D2SW-P01L2□□

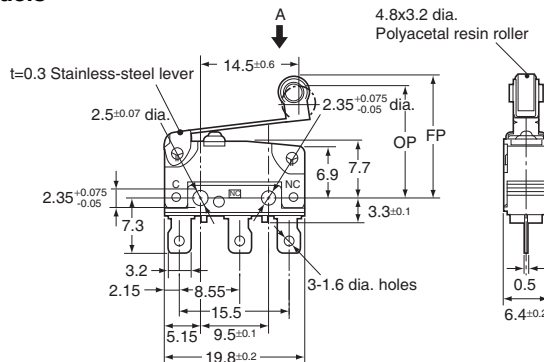
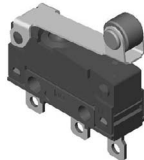

Operating characteristics		Model	D2SW-P2L2□□ D2SW-P01L2□□
Operating Force	OF	Max.	0.6 N {61 gf}
Releasing Force	RF	Min.	0.05 N {5 gf}
Overtravel	OT	Min.	0.8 mm
Movement Differential	MD	Max.	0.8 mm
Free Position	FP	Max.	19.3 mm
Operating Position	OP		14.5±0.8 mm

●Simulated Roller Lever Models

D2SW-P2L3□□

D2SW-P01L3□□

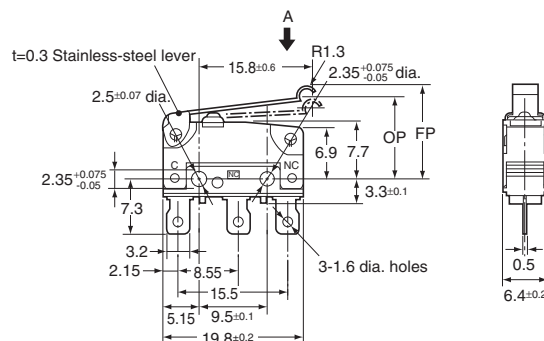
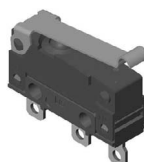

Operating characteristics		Model	D2SW-P2L3□□ D2SW-P01L3□□
Operating Force	OF	Max.	0.6 N {61 gf}
Releasing Force	RF	Min.	0.05 N {5 gf}
Overtravel	OT	Min.	0.8 mm
Movement Differential	MD	Max.	0.8 mm
Free Position	FP	Max.	15.5 mm
Operating Position	OP		10.7±0.8 mm

Note 1. Unless otherwise specified, a tolerance of ±0.4 mm applies to all dimensions.

Note 2. The operating characteristics are for operation in the A direction (↓).

Precautions

★ Please refer to "Basic Switches Common Precautions" for correct use.

Cautions

●Degree of Protection

- Do not use this product in water.
Although this models satisfy the test conditions for the standard given below, this test is to check the ingress of water into the switch enclosure after submerging the Switch in water for a given time. Satisfying this test condition does not mean that the Switch can be used in water.

JIS C0920:

Degrees of protection provided by enclosures of electrical apparatus (IP Code)

IEC 60529:

Degrees of protection provided by enclosures (IP Code)

Degree of protection: IP67

(check water intrusion after immersion for 30 min submerged 1 m underwater)

- Do not operate the Switch when it is exposed to water spray, or when water drops adhere to the Switch surface, or during sudden temperature changes, otherwise water may intrude into the interior of the Switch due to a suction effect.
- Prevent the Switch from coming into contact with oil and chemicals.
Otherwise, damage to or deterioration of Switch materials may result.
- Do not use the Switch in areas where it is exposed to silicon adhesives, oil, or grease, otherwise faulty contact may result due to the generation of silicon oxide.
- The environment-resistant performance of the switch differs depending on operating loads, ambient atmospheres, and installation conditions, etc. Please perform an operating test of the switch in advance under actual usage conditions.

●Soldering

●Connecting to Solder Terminals

When soldering the lead wire to the terminal, first insert the lead wire conductor through the terminal hole and then conduct soldering.

Complete the soldering at the iron tip temperature between 350 to 400°C within 3 seconds, and do not apply any external force for 1 minute after soldering. Soldering at a excessively high temperature or soldering for more than 3 s may deteriorate the characteristics of the Switch.

●Connecting to Quick-connect Terminals

Wire the quick-connect terminals (#110) with receptacles. Insert the terminals straight into the receptacles. Applying excessive external force laterally may cause deformation of terminals and may damage the housings.

●Connecting to PCB terminals

When using automatic soldering baths, we recommend soldering at 260±5°C within 5 seconds. Make sure that the liquid surface of the solder does not flow over the edge of the board.

When soldering terminals manually, complete the soldering at the iron tip temperature between 350 to 400°C within 3 seconds, and do not apply any external force for 1 minute after soldering. When applying solder, keep the solder away from the case of the Switch and do not allow solder or flux to flow into the case.

●Side-actuated (Cam/Dog) Operation

- When using a cam or dog to operate the Switch, factors such as the operating speed, operating frequency, push-button indentation, and material and shape of the cam or dog will affect the durability of the Switch. Confirm performance specifications under actual operation conditions before using the Switch in applications.

Correct Use

●Mounting

- Turn OFF the power supply before mounting or removing the Switch, wiring, or performing maintenance or inspection. Failure to do so may result in electric shock or burning.
- Use M2.3 mounting screws with plane washers or spring washers to securely mount the Switch.
Tighten the screws to a torque of 0.23 to 0.26 N·m {2.3 to 2.7 kgf·cm}. Exceeding the specified torque may result in deterioration of the sealing or damage.

●Operating Body

- Use an operating body with low frictional resistance and of a shape that will not interfere with the sealing rubber, otherwise the plunger may be damaged or the sealing may deteriorate. With the pin plunger models, set the Switch so that the plunger can be pushed in from directly above. Since the plunger is covered with a rubber cap, applying a force from lateral directions may cause damage to the plunger or reduction in the sealing capability. Since the plunger is covered with a rubber cap, applying a force from lateral directions may cause damage to the plunger or reduction in the sealing capability.

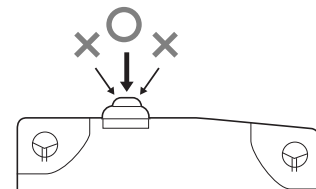

●Handling

- Do not handle the Switch in a way that may cause damage to the sealing rubber.
- When handling the Switch, ensure that uneven pressure or, as shown in the following diagram, pressure in a direction other than the operating direction is not applied to the Actuator, otherwise the Actuator or Switch may be damaged, or durability may be decreased.

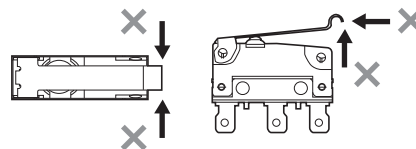

●Wiring Molded Lead Wire Models

- When wiring molded lead wire models, ensure that there is no force applied on the wire or that there are no sharp bends near the parts where the wire is drawn out. Otherwise, damage to the Switch or deterioration in the sealing may result.

●Using Micro Loads

- Using a model for ordinary loads to open or close the contact of a micro load circuit may result in faulty contact. Use models that operate in the following range. However, even when using micro load models within the following operating range, if inrush current occurs when the contact is opened or closed, it may increase the contact wear and so decrease durability. Therefore, insert a contact protection circuit where necessary. The N-level reference value applies for the minimum applicable load. This value indicates the malfunction reference level for the reliability level of 60% (λ_{60}). (JIS C5003) The equation $\lambda_{60}=0.5 \times 10^{-6} / \text{operations}$ indicates that the estimated malfunction rate is less than $\frac{1}{2,000,000}$ operations with a reliability level of 60%.

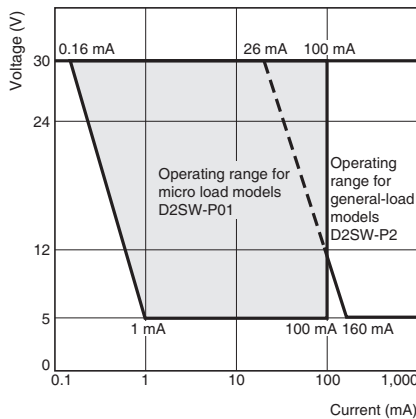

• Application examples provided in this document are for reference only. In actual applications, confirm equipment functions and safety before using the product.
 • Consult your OMRON representative before using the product under conditions which are not described in the manual or applying the product to nuclear control systems, railroad systems, aviation systems, vehicles, combustion systems, medical equipment, amusement machines, safety equipment, and other systems or equipment that may have a serious influence on lives and property if used improperly. Make sure that the ratings and performance characteristics of the product provide a margin of safety for the system or equipment, and be sure to provide the system or equipment with double safety mechanisms.

Note: Do not use this document to operate the Unit.

OMRON Corporation

ELECTRONIC AND MECHANICAL COMPONENTS COMPANY



Contact: www.omron.com/ecb

Cat. No. B109-E1-04

0812(0207)(O)

Looking for pricing, stock, or lifecycle information?

Click below to explore more details on WIN SOURCE:

-  [View D2SW-P01L3D on WIN SOURCE](#)
-  [Omron Information](#)

Optimize Your Supply Chain with WIN SOURCE Solutions

-  Global Sourcing Solution
-  Obsolete Management
-  Cost Control Management
-  Shortage Management
-  Alternative Solution
-  Excess Inventory Management