



**THE DATASHEET OF
CS20-22MOF1**



High Voltage Phase Control Thyristor

in High Voltage ISOPLUS i4-PAC™

$$\begin{aligned}
 V_{\text{DRM}} = V_{\text{RRM}} &= 2200 \text{ V} \\
 I_{\text{T(AV)}} &= 18 \text{ A} \\
 I_{\text{TSM}} &= 200 \text{ A}
 \end{aligned}$$

V_{RSM} V_{DSM} V	V_{RRM} V_{DRM} V	Type
2300	2200	CS 20-22moF1

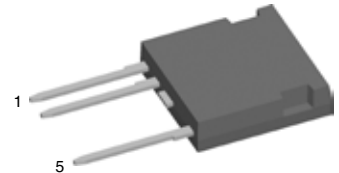
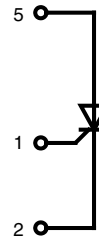

Thyristor		Maximum Ratings	
Symbol	Conditions		
$V_{\text{DRM}} / \text{RRM}$		2200	V
$I_{\text{T(AV)}}$	sine 180°; $T_{\text{C}} = 90^{\circ}\text{C}$	18	A
$I_{\text{T(AV)}}$	square; $d = 1/3$; $T_{\text{C}} = 90^{\circ}\text{C}$	16	A
I_{TSM}	sine 180°; $t = 10 \text{ ms}$; $V_{\text{R}} = 0 \text{ V}$; $T_{\text{VJ}} = 25^{\circ}\text{C}$	200	A
$(di/dt)_{\text{cr}}$	$T_{\text{VJ}} = T_{\text{VJM}}$ repetitive, $I_{\text{T}} = 40 \text{ A}$ $f = 50 \text{ Hz}$; $t_{\text{p}} = 200 \mu\text{s}$	100	A/ μs
	$V_{\text{D}} = 2/3 V_{\text{DRM}}$ $I_{\text{G}} = 0.45 \text{ A}$ $di_{\text{G}}/dt = 0.45 \text{ A}/\mu\text{s}$ non repetitive, $I_{\text{T}} = 20 \text{ A}$	250	A/ μs
$(dv/dt)_{\text{cr}}$	$T_{\text{VJ}} = T_{\text{VJM}}$; $V_{\text{D}} = 2/3 V_{\text{DRM}}$ $R_{\text{GK}} = \infty$; method 1 (linear voltage rise)	2500	V/ μs
		Characteristic Values ($T_{\text{VJ}} = 25^{\circ}\text{C}$, unless otherwise specified)	
Symbol	Conditions	typ.	max.
V_{T}	$I_{\text{T}} = 20 \text{ A}$; $T_{\text{VJ}} = 25^{\circ}\text{C}$ $T_{\text{VJ}} = 125^{\circ}\text{C}$	1.3 1.3	1.5 V
V_{GT}	$V_{\text{D}} = 6 \text{ V}$		2.3 V
I_{GT}			250 mA
V_{GD}	$V_{\text{D}} = 2/3 V_{\text{DRM}}$; $T_{\text{VJ}} = T_{\text{VJM}}$		0.2 V
I_{GD}			5 mA
I_{L}	$t_{\text{p}} = 10 \mu\text{s}$; $V_{\text{D}} = 6 \text{ V}$ $I_{\text{G}} = 0.45 \text{ A}$; $di_{\text{G}}/dt = 0.45 \text{ A}/\mu\text{s}$		500 mA
I_{H}	$V_{\text{D}} = 6 \text{ V}$; $R_{\text{GK}} = \infty$		150 mA
t_{gd}	$V_{\text{D}} = 1/2 V_{\text{DRM}}$ $I_{\text{G}} = 0.45 \text{ A}$; $di_{\text{G}}/dt = 0.45 \text{ A}/\mu\text{s}$		2 μs
$I_{\text{R}}, I_{\text{D}}$	$V_{\text{R}} = V_{\text{RRM}}$; $V_{\text{D}} = V_{\text{DRM}}$; $T_{\text{VJ}} = 25^{\circ}\text{C}$ $T_{\text{VJ}} = 125^{\circ}\text{C}$		50 μA mA
R_{thJC}	DC current		0.92 K/W

Features

- high voltage thyristor
 - for line frequency
 - chip technology for long term stability
- ISOPLUS i4-PAC™
 - high voltage package
 - isolated back surface
 - enlarged creepage towards heatsink
 - enlarged creepage between high voltage pins
 - application friendly pinout
 - high reliability
 - industry standard outline

Applications

- controlled rectifiers
 - power supplies
 - drives
- AC switches
- capacitor discharge control
 - flash tubes
 - X-ray and laser generators

Component		
Symbol	Conditions	Maximum Ratings
T_{VJ}		-40 ... +125 °C
T_{stg}		-55 ... +125 °C
V_{ISOL}	$I_{ISOL} \leq 1 \text{ mA}; 50/60 \text{ Hz}$	2500 V~
F_C	mounting force with clip	20...120 N

Symbol	Conditions	Characteristic Values	
		min.	typ.
d_S, d_A	A pin - K pin	7	mm
	pin - backside metal	5.5	mm
R_{thCH}	with heatsink compound		0.15 K/W
Weight			5.5 g

Dimensions in mm (1 mm = 0.0394")

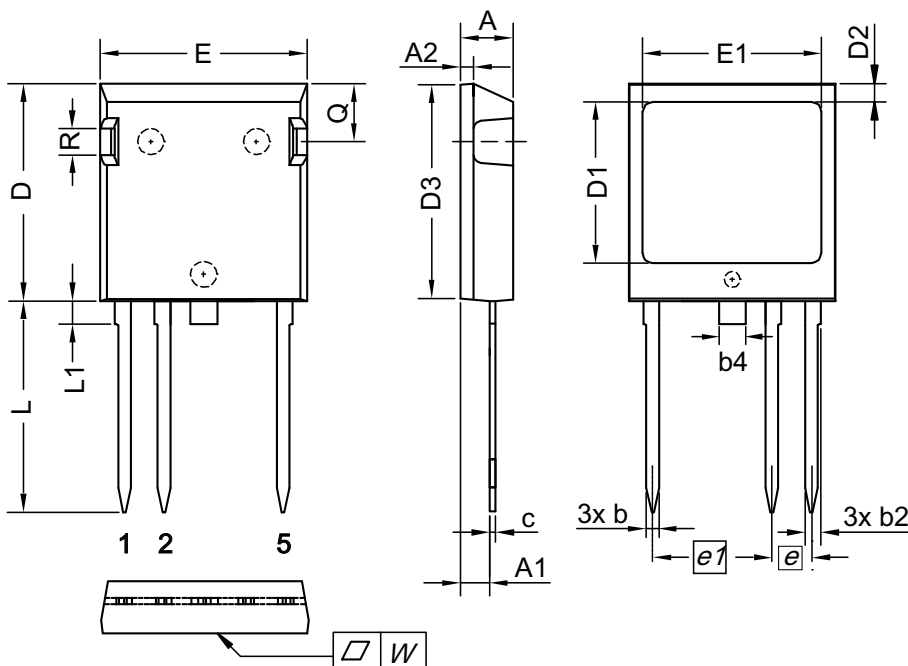

Dim.	Millimeter		Inches	
	min	max	min	max
A	4.83	5.21	0.190	0.205
A1	2.59	3.00	0.102	0.118
A2	1.17	2.16	0.046	0.085
b	1.14	1.40	0.045	0.055
b2	1.47	1.73	0.058	0.068
b4	2.54	2.79	0.100	0.110
c	0.51	0.74	0.020	0.029
D	20.80	21.34	0.819	0.840
D1	14.99	15.75	0.590	0.620
D2	1.65	2.03	0.065	0.080
D3	20.30	20.70	0.799	0.815
E	19.56	20.29	0.770	0.799
E1	16.76	17.53	0.660	0.690
e	3.81 BSC		0.150 BSC	
e1	11.43 BSC		0.450 BSC	
L	19.81	21.34	0.780	0.840
L1	2.11	2.59	0.083	0.102
Q	5.33	6.20	0.210	0.244
R	2.54	4.57	0.100	0.180
W	-	0.10	-	0.004

Die konvexe Form des Substrates ist typ. < 0.05 mm über der Kunststoffoberfläche der Bauteilunterseite
 The convexbow of substrate is typ. < 0.05 mm over plastic surface level of device bottom side

Looking for pricing, stock, or lifecycle information?

Click below to explore more details on WIN SOURCE:

- ⊖ [View CS20-22MOF1 on WIN SOURCE](#)
- ⊖ [IXYS Information](#)

Optimize Your Supply Chain with WIN SOURCE Solutions

- ✓ Global Sourcing Solution
- ✓ Obsolete Management
- ✓ Cost Control Management
- ✓ Shortage Management
- ✓ Alternative Solution
- ✓ Excess Inventory Management