



THE DATASHEET OF LM392DGKR



FEATURES

- **Wide Power-Supply Voltage Range**
 - Single Supply: 3 V to 32 V
 - Dual Supply: ± 1.5 V to ± 16 V
- **Low Supply-Current Drain Essentially Independent of Supply Voltage: 600 μ A**
- **Low Input Biasing Current: 50 nA**
- **Low Input Offset Voltage: 2 mV**
- **Low Input Offset Current: 5 nA**
- **Input Common-Mode Voltage Range Includes Ground**
- **Differential Input Voltage Range Equals Power-Supply Voltage**
- **Additional Operational Amplifier Features**
 - Internally Frequency Compensated for Unity Gain
 - Large DC Voltage Gain: 100 dB
 - Wide Bandwidth (Unity Gain): 1 MHz
 - Large Output Voltage Swing: 0 V to $V_+ - 1.5$ V

- **Additional Comparator Features**
 - Low Output Saturation Voltage: 250 mV at 4 mA
 - Output Voltage Compatible With All Types of Logic Systems

ADVANTAGES

- **Eliminates Need for Dual Power Supplies**
- **An Internally Compensated Operational Amplifier and a Precision Comparator in the Same Package**
- **Allows Sensing at or Near Ground**

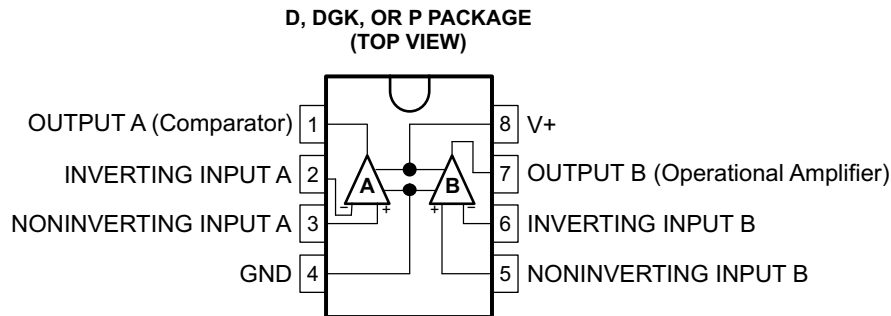

DESCRIPTION/ORDERING INFORMATION

The LM392 consists of two independent building-block circuits. One is a high-gain internally-frequency-compensated operational amplifier, and the other is a precision voltage comparator. Both the operational amplifier and the voltage comparator are designed to operate from a single power supply over a wide range of voltages. Both circuits have input stages that force the common-mode input down to ground when operating from a single power supply. Operation from split power supplies also is possible, and the low power-supply current is independent of the magnitude of the supply voltage.

Applications include transducer amplifiers with pulse shapers, DC gain blocks with level detectors, and VCOs, as well as all conventional operational amplifier or voltage-comparator circuits. The LM392 can be operated directly from the standard 5-V power-supply voltage used in digital systems, and the output of the comparator interfaces directly with either TTL or CMOS logic. In addition, the low-power drain makes the LM392 extremely useful in the design of portable equipment.



Please be aware that an important notice concerning availability, standard warranty, and use in critical applications of Texas Instruments semiconductor products and disclaimers thereto appears at the end of this data sheet.

ORDERING INFORMATION

T _A	PACKAGE ⁽¹⁾		ORDERABLE PART NUMBER	TOP-SIDE MARKING
0°C to 70°C	MSOP – DGK	Reel of 250	LM392DGKT	PREVIEW
		Reel of 2500	LM392DGKR	
	PDIP – P	Tube of 50	LM392P	LM392P
	SOIC – D	Tube of 75	LM392D	LM392
		Reel of 2500	LM392DR	

(1) Package drawings, standard packing quantities, thermal data, symbolization, and PCB design guidelines are available at www.ti.com/sc/package.

SCHEMATIC DIAGRAM

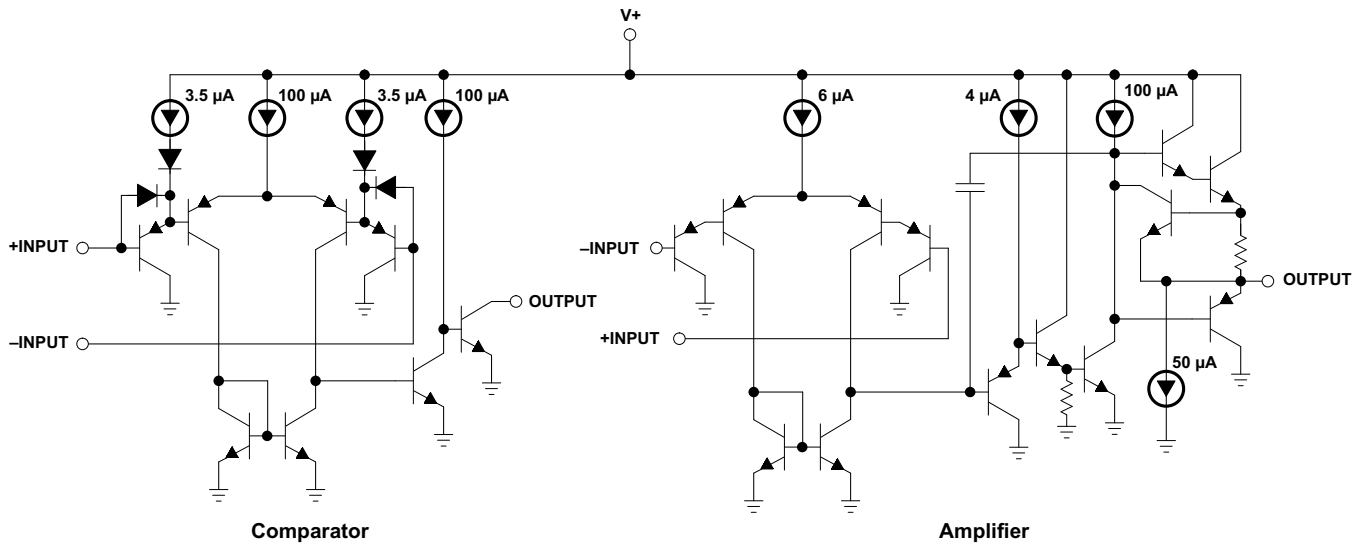

Absolute Maximum Ratings⁽¹⁾

over operating free-air temperature range (unless otherwise noted)

		MIN	MAX	UNIT
V+	Supply voltage	Single supply	32	V
		Dual supply	±16	
V _{ID}	Differential input voltage		32	V
V _{IN}	Input voltage range	–0.3	32	V
I _I	Input current ⁽²⁾	V _{IN} < –0.3 V	50	mA
t _{short}	Duration of output short circuit to ground ⁽³⁾		Continuous	
θ _{JA}	Package thermal impedance, junction to free air ⁽⁴⁾	D package	97	°C/W
		DGK package	172	
		P package	84	
T _{lead}	Lead temperature during soldering	10 s maximum	260	°C
T _{stg}	Storage temperature range	–65	150	°C

- (1) Stresses beyond those listed under *Absolute Maximum Ratings* may cause permanent damage to the device. These are stress ratings only, and functional operation of the device at these or any other conditions beyond those indicated under *Recommended Operating Conditions* is not implied. Exposure to absolute-maximum-rated conditions for extended periods may affect device reliability.
- (2) This input current exists only when the voltage at any of the input leads is driven negative. It is due to the collector-base junction of the input PNP transistors becoming forward biased and thereby acting as input diode clamps. In addition to this diode action, there is also lateral NPN parasitic transistor action on the device. This transistor action can cause the output voltages of the amplifiers to go to the V+ voltage level (or to ground for a large overdrive) for the time duration that an input is driven negative. This is not destructive, and normal output states reestablish when the input voltage, which was negative, again returns to a value greater than –0.3 V (at 25°C).
- (3) Short circuits from the output to V+ can cause excessive heating and eventual destruction. When considering short circuits to ground, the maximum output current is approximately 40 mA for the operational amplifier and 30 mA for the comparator, independent of the magnitude of V+. At values of supply voltage in excess of 15 V, continuous short circuits can exceed the power dissipation ratings and cause eventual destruction.
- (4) Package thermal impedance is calculated in accordance with JESD 51-7.

Recommended Operating Conditions

		MIN	MAX	UNIT	
V+	Supply voltage	Single supply	3	32	V
		Dual supply	±1.5	±16	
T _A	Operating free-air temperature	0	70	°C	

Electrical Characteristics

V+ = 5 V (unless otherwise noted)

PARAMETER		TEST CONDITIONS		T _A	MIN	TYP	MAX	UNIT
V _{IO}	Input offset voltage	At output switch point, V _O ≈ 1.4 V, R _S = 0 Ω, V+ = 5 V to 30 V, V _{CM} = 0 V to (V+ – 1.5 V)		25°C		±2	±5	mV
				0°C to 70°C			±7	
I _{IB}	Input bias current	IN(+) or IN(–), V _{CM} = 0 V ⁽¹⁾		25°C		50	205	nA
		IN(+) or IN(–)		0°C to 70°C			400	
I _{IO}	Input offset current	IN(+) – IN(–)		25°C		±5	±50	nA
				0°C to 70°C			150	
V _{CM}	Input common-mode voltage ⁽²⁾	V+ = 30 V		25°C	0		V+ – 1.5	V
				0°C to 70°C	0		V+ – 2	
I+	Supply current	R _L = ∞	V+ = 30 V	0°C to 70°C		1	2	mA
			V+ = 5 V			0.5	1	
	Amplifier-to-amplifier coupling	f = 1 kHz to 20 kHz, Input referred ⁽³⁾		25°C		–100		dB
V _{DI}	Differential input voltage	All V _{IN} ≥ 0 V (or V–, if used) ⁽⁴⁾		0°C to 70°C			32	V

- (1) The direction of the input current is out of the device due to the PNP input stage. This current essentially is constant and independent of the state of the output, so no loading change exists on the input lines.
- (2) The input common-mode voltage or either input signal voltage should not be allowed to go negative by more than 0.3 V. The upper end of the common-mode voltage range is V+ – 1.5 V, but either or both inputs can go to 32 V without damage.
- (3) Due to proximity of external components, ensure that coupling is not originating via the stray capacitance between these external parts. This typically can be detected, as this type of capacitive coupling increases at higher frequencies.
- (4) Positive excursions of input voltage may exceed the power-supply level. As long as the other input voltage remains within the common-mode range, the comparator provides a proper output state. The input voltage to the operational amplifier should not exceed the power-supply level. The input voltage state must not be less than –0.3 V (or 0.3 V below the magnitude of the negative power supply, if used) on either amplifier.

Electrical Characteristics, Operational Amplifier Only

V+ = 5 V (unless otherwise noted)

PARAMETER		TEST CONDITIONS		T _A	MIN	TYP	MAX	UNIT
A _{VD}	Large signal voltage gain	V+ = 15 V, V _O swing = 1 V to 11 V, R _L = 2 kΩ		25°C	25	100		V/mV
V _{OS}	Output voltage swing	R _L = 2 kΩ		25°C	0		V+ – 1.5	V
CMRR	Common-mode rejection ratio	V _{CM} = 0 V to (V+ – 1.5 V)		25°C	65	70		dB
k _{SVR}	Power-supply rejection ratio			25°C	65	100		dB
I _{source}	Output source current	V _{IN(+)} = 1 V, V _{IN(–)} = 0 V, V+ = 15 V, V _O = 2 V		25°C	20	40		mA
I _{sink}	Output sink current	V _{IN(–)} = 1 V, V _{IN(+)} = 0 V, V+ = 15 V	V _O = 2 V	25°C		10	20	mA
			V _O = 200 mV			12	50	μA
αV _{IO}	Input offset voltage drift	R _S = 0 Ω		0°C to 70°C		7		μV/°C
αI _{IO}	Input offset current drift	R _S = 0 Ω		0°C to 70°C		10		pA/°C

Electrical Characteristics, Comparator Only
 $V_+ = 5\text{ V}$ (unless otherwise noted)

PARAMETER		TEST CONDITIONS	T_A	MIN	TYP	MAX	UNIT
V_G	Voltage gain	$R_L \geq 15\text{ k}\Omega$, $V_+ = 15\text{ V}$	25°C	50	200		V/mV
t_{LSR}	Large signal response time	$V_{IN} = \text{TTL logic swing}$, $V_{REF} = 1.4\text{ V}$, $V_{RL} = 5\text{ V}$, $R_L = 5.1\text{ k}\Omega$	25°C		300		ns
t_R	Response time	$V_{RL} = 5\text{ V}$, $R_L = 5.1\text{ k}\Omega$	25°C		1.3		μs
I_{SINK}	Output sink current	$V_{IN(-)} = 1\text{ V}$, $V_{IN(+)} = 0\text{ V}$, $V_O \geq 1.5\text{ V}$	25°C	6	16		mA
V_S	Saturation voltage	$V_{IN(-)} \geq 1\text{ V}$, $V_{IN(+)} = 0$, $I_{SINK} \leq 4\text{ mA}$	25°C		250	400	mV
			0°C to 70°C			700	
I_{LO}	Output leakage current	$V_{IN(-)} = 0$, $V_{IN(+)} \geq 1\text{ V}$	$V_O = 5\text{ V}$	25°C		0.1	nA
			$V_O = 30\text{ V}$	0°C to 70°C			1

PACKAGING INFORMATION

Orderable Device	Status (1)	Package Type	Package Drawing	Pins	Package Qty	Eco Plan (2)	Lead/Ball Finish (6)	MSL Peak Temp (3)	Op Temp (°C)	Device Marking (4/5)	Samples
LM392D	ACTIVE	SOIC	D	8	75	Green (RoHS & no Sb/Br)	CU NIPDAU	Level-1-260C-UNLIM	0 to 70	LM392	Samples
LM392DGKR	ACTIVE	VSSOP	DGK	8	2500	Green (RoHS & no Sb/Br)	CU NIPDAU	Level-1-260C-UNLIM	0 to 70	M7L	Samples
LM392DGKT	ACTIVE	VSSOP	DGK	8	250	Green (RoHS & no Sb/Br)	CU NIPDAU	Level-1-260C-UNLIM	0 to 70	M7L	Samples
LM392DGKTG4	ACTIVE	VSSOP	DGK	8	250	Green (RoHS & no Sb/Br)	CU NIPDAU	Level-1-260C-UNLIM	0 to 70	M7L	Samples
LM392DR	ACTIVE	SOIC	D	8	2500	Green (RoHS & no Sb/Br)	CU NIPDAU CU SN	Level-1-260C-UNLIM	0 to 70	LM392	Samples
LM392DRG4	ACTIVE	SOIC	D	8	2500	Green (RoHS & no Sb/Br)	CU NIPDAU	Level-1-260C-UNLIM	0 to 70	LM392	Samples
LM392P	ACTIVE	PDIP	P	8	50	Green (RoHS & no Sb/Br)	CU NIPDAU	N / A for Pkg Type	0 to 70	LM392P	Samples

(1) The marketing status values are defined as follows:

ACTIVE: Product device recommended for new designs.

LIFEBUY: TI has announced that the device will be discontinued, and a lifetime-buy period is in effect.

NRND: Not recommended for new designs. Device is in production to support existing customers, but TI does not recommend using this part in a new design.

PREVIEW: Device has been announced but is not in production. Samples may or may not be available.

OBSELETE: TI has discontinued the production of the device.

(2) **RoHS:** TI defines "RoHS" to mean semiconductor products that are compliant with the current EU RoHS requirements for all 10 RoHS substances, including the requirement that RoHS substance do not exceed 0.1% by weight in homogeneous materials. Where designed to be soldered at high temperatures, "RoHS" products are suitable for use in specified lead-free processes. TI may reference these types of products as "Pb-Free".

RoHS Exempt: TI defines "RoHS Exempt" to mean products that contain lead but are compliant with EU RoHS pursuant to a specific EU RoHS exemption.

Green: TI defines "Green" to mean the content of Chlorine (Cl) and Bromine (Br) based flame retardants meet JS709B low halogen requirements of <=100ppm threshold. Antimony trioxide based flame retardants must also meet the <=1000ppm threshold requirement.

(3) MSL, Peak Temp. - The Moisture Sensitivity Level rating according to the JEDEC industry standard classifications, and peak solder temperature.

(4) There may be additional marking, which relates to the logo, the lot trace code information, or the environmental category on the device.

(5) Multiple Device Markings will be inside parentheses. Only one Device Marking contained in parentheses and separated by a "-" will appear on a device. If a line is indented then it is a continuation of the previous line and the two combined represent the entire Device Marking for that device.

⁽⁶⁾ Lead/Ball Finish - Orderable Devices may have multiple material finish options. Finish options are separated by a vertical ruled line. Lead/Ball Finish values may wrap to two lines if the finish value exceeds the maximum column width.

Important Information and Disclaimer: The information provided on this page represents TI's knowledge and belief as of the date that it is provided. TI bases its knowledge and belief on information provided by third parties, and makes no representation or warranty as to the accuracy of such information. Efforts are underway to better integrate information from third parties. TI has taken and continues to take reasonable steps to provide representative and accurate information but may not have conducted destructive testing or chemical analysis on incoming materials and chemicals. TI and TI suppliers consider certain information to be proprietary, and thus CAS numbers and other limited information may not be available for release.

In no event shall TI's liability arising out of such information exceed the total purchase price of the TI part(s) at issue in this document sold by TI to Customer on an annual basis.

TAPE AND REEL INFORMATION

QUADRANT ASSIGNMENTS FOR PIN 1 ORIENTATION IN TAPE

*All dimensions are nominal

Device	Package Type	Package Drawing	Pins	SPQ	Reel Diameter (mm)	Reel Width W1 (mm)	A0 (mm)	B0 (mm)	K0 (mm)	P1 (mm)	W (mm)	Pin1 Quadrant
LM392DGKR	VSSOP	DGK	8	2500	330.0	12.4	5.3	3.4	1.4	8.0	12.0	Q1
LM392DGKT	VSSOP	DGK	8	250	177.8	12.4	5.3	3.4	1.4	8.0	12.0	Q1
LM392DR	SOIC	D	8	2500	330.0	12.8	6.4	5.2	2.1	8.0	12.0	Q1
LM392DR	SOIC	D	8	2500	330.0	12.4	6.4	5.2	2.1	8.0	12.0	Q1
LM392DRG4	SOIC	D	8	2500	330.0	12.4	6.4	5.2	2.1	8.0	12.0	Q1

TAPE AND REEL BOX DIMENSIONS

*All dimensions are nominal

Device	Package Type	Package Drawing	Pins	SPQ	Length (mm)	Width (mm)	Height (mm)
LM392DGKR	VSSOP	DGK	8	2500	358.0	335.0	35.0
LM392DGKT	VSSOP	DGK	8	250	202.0	201.0	28.0
LM392DR	SOIC	D	8	2500	364.0	364.0	27.0
LM392DR	SOIC	D	8	2500	340.5	338.1	20.6
LM392DRG4	SOIC	D	8	2500	340.5	338.1	20.6



D0008A

PACKAGE OUTLINE

SOIC - 1.75 mm max height

SMALL OUTLINE INTEGRATED CIRCUIT

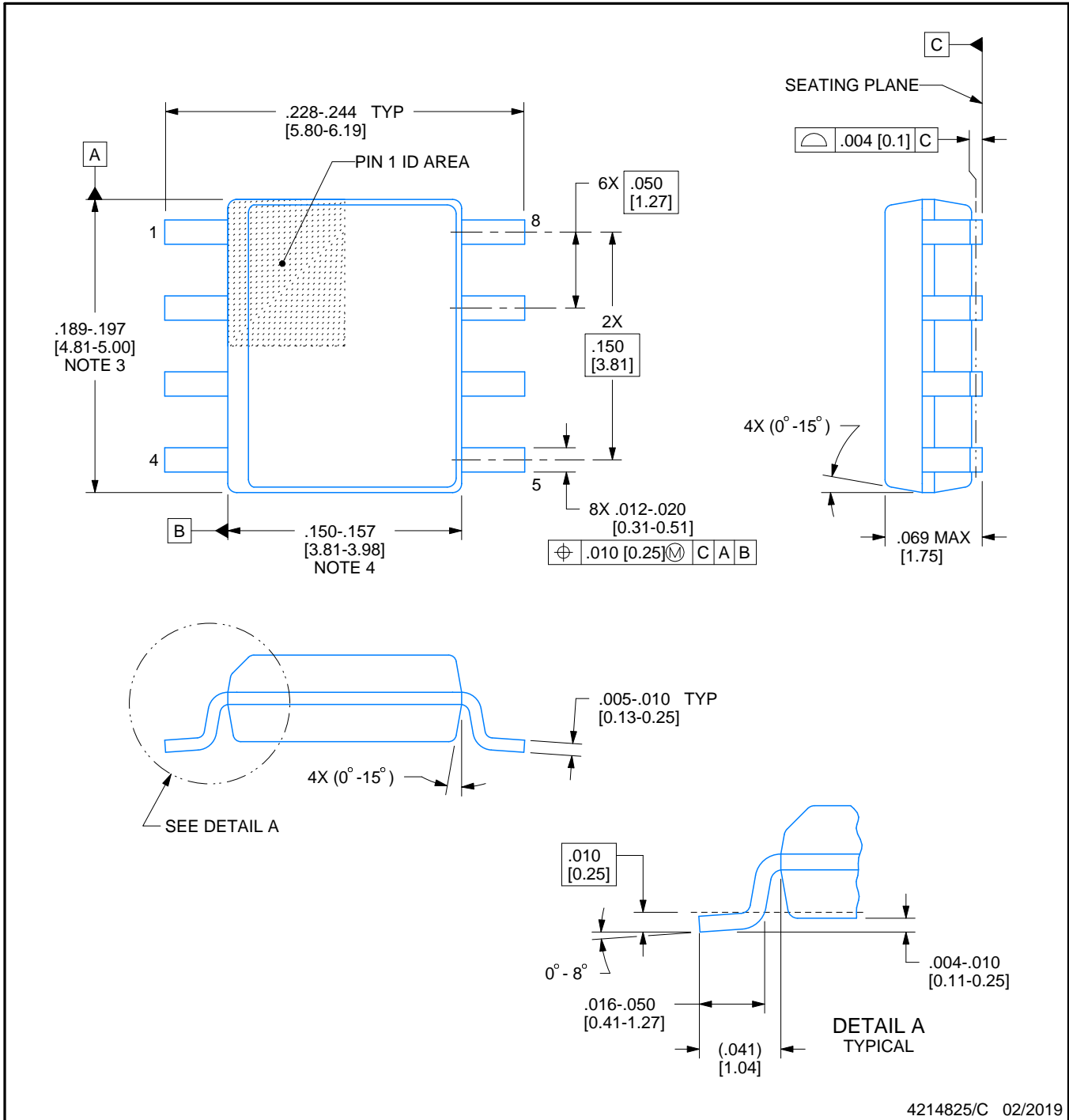

4214825/C 02/2019

NOTES:

1. Linear dimensions are in inches [millimeters]. Dimensions in parenthesis are for reference only. Controlling dimensions are in inches. Dimensioning and tolerancing per ASME Y14.5M.
2. This drawing is subject to change without notice.
3. This dimension does not include mold flash, protrusions, or gate burrs. Mold flash, protrusions, or gate burrs shall not exceed .006 [0.15] per side.
4. This dimension does not include interlead flash.
5. Reference JEDEC registration MS-012, variation AA.

EXAMPLE BOARD LAYOUT

D0008A

SOIC - 1.75 mm max height

SMALL OUTLINE INTEGRATED CIRCUIT



LAND PATTERN EXAMPLE
 EXPOSED METAL SHOWN
 SCALE:8X



SOLDER MASK DETAILS

4214825/C 02/2019

NOTES: (continued)

- 6. Publication IPC-7351 may have alternate designs.
- 7. Solder mask tolerances between and around signal pads can vary based on board fabrication site.

EXAMPLE STENCIL DESIGN

D0008A

SOIC - 1.75 mm max height

SMALL OUTLINE INTEGRATED CIRCUIT



SOLDER PASTE EXAMPLE
BASED ON .005 INCH [0.125 MM] THICK STENCIL
SCALE:8X

4214825/C 02/2019

NOTES: (continued)

8. Laser cutting apertures with trapezoidal walls and rounded corners may offer better paste release. IPC-7525 may have alternate design recommendations.
9. Board assembly site may have different recommendations for stencil design.

P (R-PDIP-T8)

PLASTIC DUAL-IN-LINE PACKAGE



- NOTES:
- A. All linear dimensions are in inches (millimeters).
 - B. This drawing is subject to change without notice.
 - C. Falls within JEDEC MS-001 variation BA.

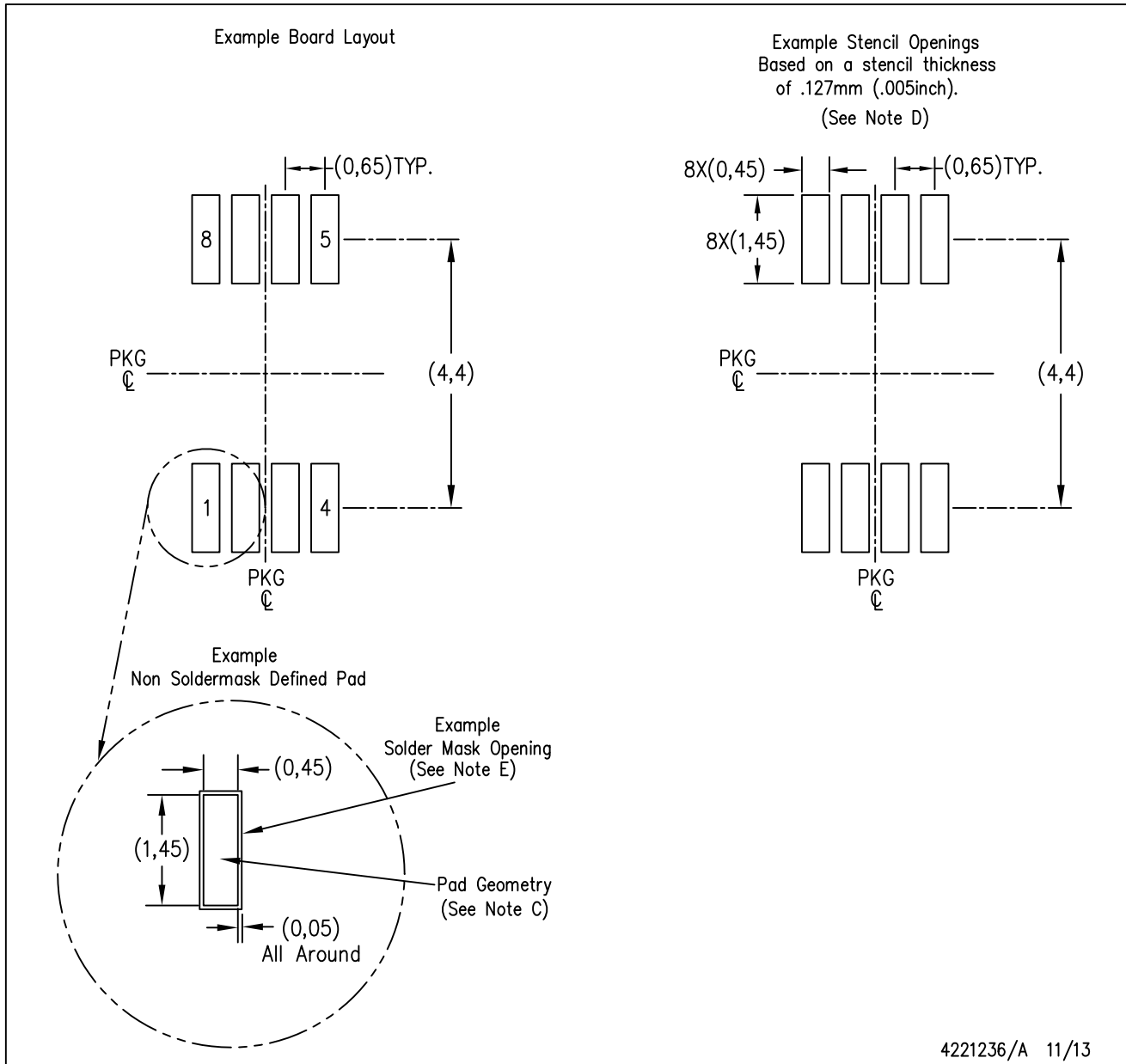

- NOTES:
- A. All linear dimensions are in millimeters.
 - B. This drawing is subject to change without notice.
 - C. Publication IPC-7351 is recommended for alternate designs.
 - D. Laser cutting apertures with trapezoidal walls and also rounding corners will offer better paste release. Customers should contact their board assembly site for stencil design recommendations. Refer to IPC-7525 for other stencil recommendations.
 - E. Customers should contact their board fabrication site for solder mask tolerances between and around signal pads.

IMPORTANT NOTICE AND DISCLAIMER

TI PROVIDES TECHNICAL AND RELIABILITY DATA (INCLUDING DATASHEETS), DESIGN RESOURCES (INCLUDING REFERENCE DESIGNS), APPLICATION OR OTHER DESIGN ADVICE, WEB TOOLS, SAFETY INFORMATION, AND OTHER RESOURCES "AS IS" AND WITH ALL FAULTS, AND DISCLAIMS ALL WARRANTIES, EXPRESS AND IMPLIED, INCLUDING WITHOUT LIMITATION ANY IMPLIED WARRANTIES OF MERCHANTABILITY, FITNESS FOR A PARTICULAR PURPOSE OR NON-INFRINGEMENT OF THIRD PARTY INTELLECTUAL PROPERTY RIGHTS.

These resources are intended for skilled developers designing with TI products. You are solely responsible for (1) selecting the appropriate TI products for your application, (2) designing, validating and testing your application, and (3) ensuring your application meets applicable standards, and any other safety, security, or other requirements. These resources are subject to change without notice. TI grants you permission to use these resources only for development of an application that uses the TI products described in the resource. Other reproduction and display of these resources is prohibited. No license is granted to any other TI intellectual property right or to any third party intellectual property right. TI disclaims responsibility for, and you will fully indemnify TI and its representatives against, any claims, damages, costs, losses, and liabilities arising out of your use of these resources.

TI's products are provided subject to TI's Terms of Sale (www.ti.com/legal/termsofsale.html) or other applicable terms available either on ti.com or provided in conjunction with such TI products. TI's provision of these resources does not expand or otherwise alter TI's applicable warranties or warranty disclaimers for TI products.

Mailing Address: Texas Instruments, Post Office Box 655303, Dallas, Texas 75265
Copyright © 2019, Texas Instruments Incorporated

Looking for pricing, stock, or lifecycle information?

Click below to explore more details on WIN SOURCE:

 [View LM392DGKR](#) on WIN SOURCE

 [Texas Instruments](#) Information

Optimize Your Supply Chain with WIN SOURCE Solutions

-  Global Sourcing Solution
-  Obsolete Management
-  Cost Control Management
-  Shortage Management
-  Alternative Solution
-  Excess Inventory Management