



# THE DATASHEET OF CAT4104V-GT3



# 700 mA Quad Channel Constant Current LED Driver

## CAT4104

### Description

The CAT4104 provides four matched low dropout current sinks to drive high-brightness LED strings up to 175 mA per channel. The LED channel current is set by an external resistor connected to the RSET pin. The LED pins are compatible with high voltage up to 25 V supporting applications with long strings of LEDs.

The EN/PWM logic input supports the device enable and high frequency external Pulse Width Modulation (PWM) dimming control.

Thermal shutdown protection is incorporated in the device to disable the LED outputs whenever the die temperature exceeds 150°C.

The device is available in the 8-pad TDFN 2 mm x 3 mm package and the SOIC 8-Lead 150 mil wide package.

### Features

- 4 Matched LED Current Sinks up to 175 mA
- Up to 25 V Operation on LED Pins
- Low Dropout Current Source (0.4 V at 175 mA)
- LED Current Set by External Resistor
- High Frequency PWM Dimming via EN/PWM
- “Zero” Current Shutdown Mode
- Thermal Shutdown Protection
- TDFN 8-pad 2 x 3 mm and SOIC 8-lead Packages
- These Devices are Pb-Free, Halogen Free/BFR Free and are RoHS Compliant

### Applications

- Automotive Lighting
- General and Architectural Lighting
- LCD Backlight

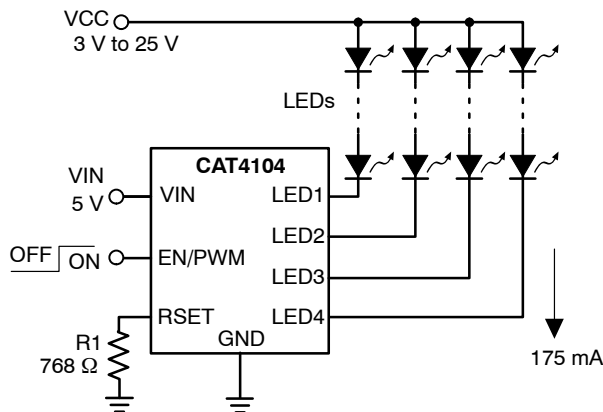

Figure 1. Typical Application Circuit



SOIC-8  
V SUFFIX  
CASE 751BD



TDFN-8  
VP SUFFIX  
CASE 511AK

### PIN CONNECTIONS

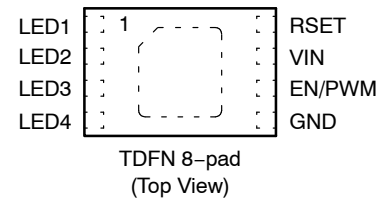
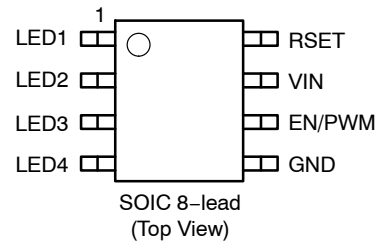

### MARKING DIAGRAMS

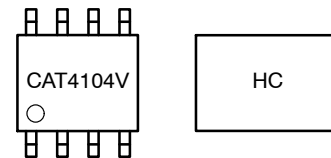

CAT4104V = CAT4104V  
HC = CAT4104VP2

### ORDERING INFORMATION

Device	Package	Shipping
CAT4104V-GT3 (Note 1)	SOIC-8 (Pb-Free)	3,000/ Tape & Reel
CAT4104VP2-GT3 (Note 1)	TDFN-8 (Pb-Free)	3,000/ Tape & Reel

1. Lead Finish is NiPdAu

# CAT4104

**Table 1. ABSOLUTE MAXIMUM RATINGS**

Parameter	Rating	Unit
VIN, RSET, EN/PWM Voltages	-0.3 to 6	V
LED1, LED2, LED3, LED4 Voltages	-0.3 to 25	V
Storage Temperature Range	-65 to +160	°C
Junction Temperature Range	-40 to +150	°C
Lead Temperature	300	°C

Stresses exceeding those listed in the Maximum Ratings table may damage the device. If any of these limits are exceeded, device functionality should not be assumed, damage may occur and reliability may be affected.

**Table 2. RECOMMENDED OPERATING CONDITIONS**

Parameter	Rating	Unit
VIN	3.0 to 5.5	V
Voltage applied to LED1 to LED4, outputs off	up to 25	V
Voltage applied to LED1 to LED4, outputs on	up to 6 (Note 2)	V
Ambient Temperature Range	-40 to +85	°C
I <sub>LED</sub> per LED pin	10 to 175	mA

2. Keeping LEDx pin voltage below 6 V in operation is recommended to minimize thermal dissipation in the package.

NOTE: Typical application circuit with external components is shown on page 1.

**Table 3. ELECTRICAL OPERATING CHARACTERISTICS** (Min and Max values are over the recommended operating conditions unless specified otherwise. Typical values are at VIN = 5.0 V, T<sub>AMB</sub> = 25°C.)

Symbol	Name	Conditions	Min	Typ	Max	Units
I <sub>LED-ACC</sub>	LED Current Accuracy	$\frac{I_{LEDNOM} - I_{LED}}{I_{LEDNOM}}$		±2		%
I <sub>LED-DEV</sub>	LED Channel Matching	$\frac{I_{LED} - I_{LEDAVG}}{I_{LEDAVG}}$ (Note 3)	-5	±1	+5	%
V <sub>DOUT</sub>	Dropout Voltage	I <sub>LED</sub> = 175 mA		400		mV
V <sub>RSET</sub>	RSET Pin Voltage		1.17	1.2	1.23	V
I <sub>Q</sub>	Quiescent Current	No LED, RSET = Float No LED, RSET = 770 Ω		0.6 6		mA
I <sub>QSHDN</sub>	Shutdown Current	V <sub>EN</sub> = 0 V			1	μA
R <sub>EN/PWM</sub> V <sub>HI</sub> V <sub>LO</sub>	EN/PWM Pin - Internal pull-down resistance - Logic High Level - Logic Low Level		1.3	200	0.4	kΩ V V
T <sub>SD</sub>	Thermal Shutdown			150		°C
T <sub>HYS</sub>	Thermal Hysteresis			20		°C
I <sub>LED</sub> /I <sub>RSET</sub>	RSET to LED Current gain ratio	25 mA LED current		100		
V <sub>UVLO</sub>	Undervoltage lockout (UVLO) threshold			2.0		V

3. Min and Max values are tested for I<sub>LED</sub> = 50 mA, VIN = 3.5 V, V<sub>LEDx</sub> = 0.4 V, T<sub>AMB</sub> = 25°C.

# CAT4104

**Table 4. RECOMMENDED EN/PWM TIMING** (Min and Max values are over the recommended operating conditions unless specified otherwise. Typical values are at VIN = 5.0 V, TAMB = 25°C.)

Symbol	Name	Conditions	Min	Typ	Max	Units
T <sub>PS</sub>	Turn-On time, EN/PWM rising to I <sub>LED</sub> from shutdown	I <sub>LED</sub> = 175 mA I <sub>LED</sub> = 80 mA		1.5 1.3		μs
T <sub>P1</sub>	Turn-On time, EN/PWM rising to I <sub>LED</sub>	I <sub>LED</sub> = 175 mA		600		ns
T <sub>P2</sub>	Turn-Off time, EN/PWM falling to I <sub>LED</sub>	I <sub>LED</sub> = 175 mA I <sub>LED</sub> = 80 mA		400 300		ns
T <sub>R</sub>	LED rise time	I <sub>LED</sub> = 175 mA I <sub>LED</sub> = 80 mA		700 440		ns
T <sub>F</sub>	LED fall time	I <sub>LED</sub> = 175 mA I <sub>LED</sub> = 80 mA		360 320		ns
T <sub>LO</sub>	EN/PWM low time		1			μs
T <sub>HI</sub>	EN/PWM high time		5			μs
T <sub>PWRDWN</sub>	EN/PWM low time to shutdown delay			4	8	ms

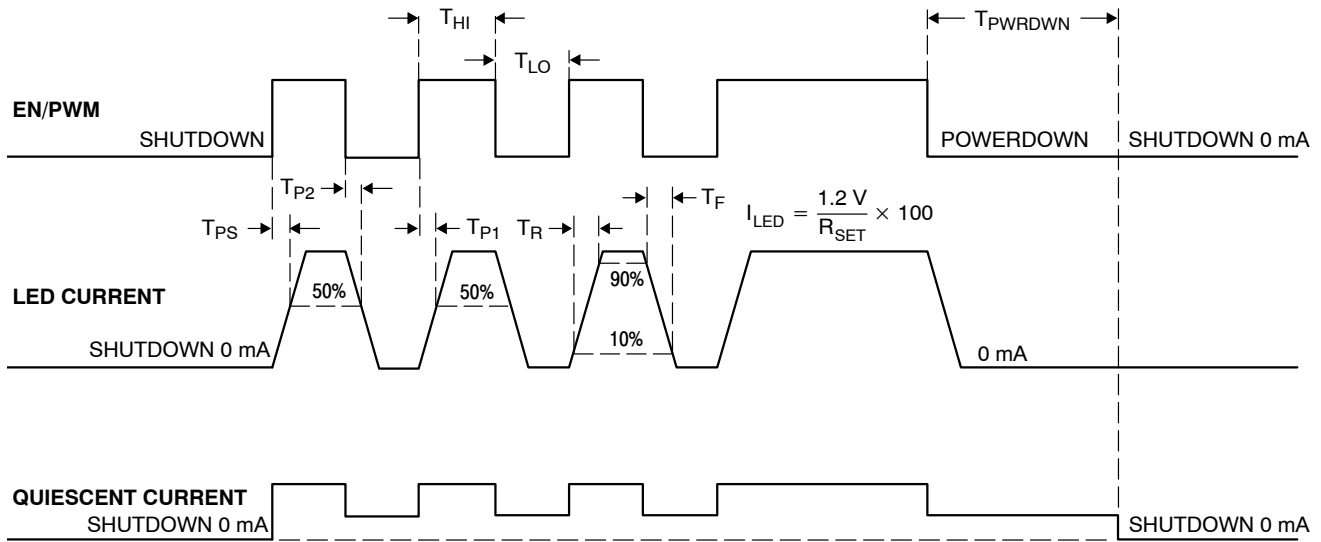

**Figure 2. CAT4104 EN/PWM Timing**

## EN/PWM OPERATION

The EN/PWM pin has two primary functions. One function enables and disables the device. The other function turns the LED channels on and off for PWM dimming control. The device has a very fast turn-on time (from EN/PWM rising to LED on) and allows “instant on” when dimming LED using a PWM signal.

Accurate linear dimming is compatible with PWM frequencies from 100 Hz to 5 kHz for PWM duty cycle down to 1%. PWM frequencies up to 50 kHz can be supported for duty cycles greater than 10%.

When performing a combination of low frequencies and small duty cycles, the device may enter shutdown mode. This has no effect on the dimming accuracy, because the turn-on time  $T_{PS}$  is very short, in the range of 1 μs.

To ensure that PWM pulses are recognized, pulse width low time  $T_{LO}$  should be longer than 1 μs. The CAT4104 enters a “zero current” shutdown mode after a 4 ms delay (typical) when EN/PWM is held low.

TYPICAL PERFORMANCE CHARACTERISTICS

(VIN = 5 V, VCC = 5 V, LED FORWARD VOLTAGE = 3.5 V, CIN = 1 MF, TAMB = 25°C UNLESS OTHERWISE SPECIFIED.)

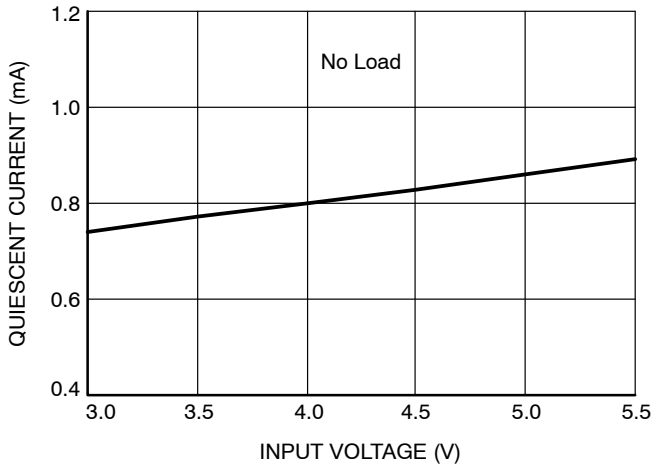

Figure 3. Quiescent Current vs. Input Voltage (RSET Open)

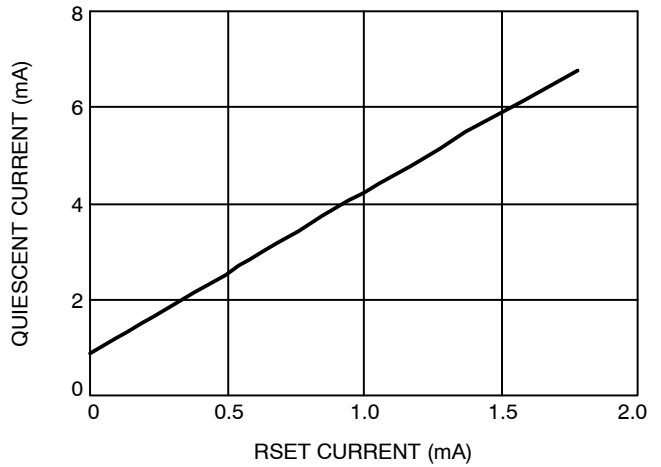

Figure 4. Quiescent Current vs. RSET Current

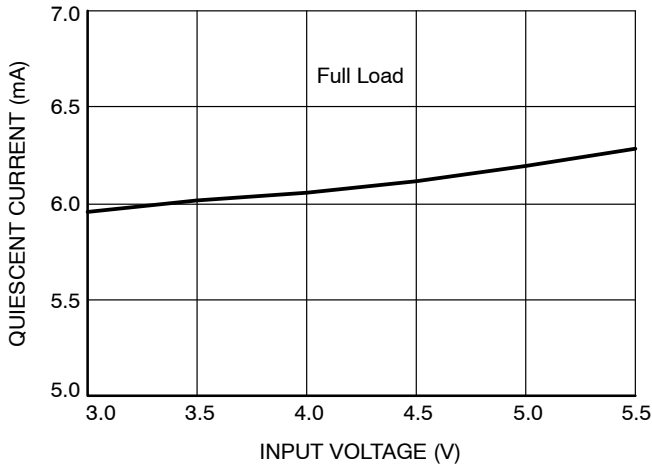

Figure 5. Quiescent Current vs. Input Voltage (Full Load)

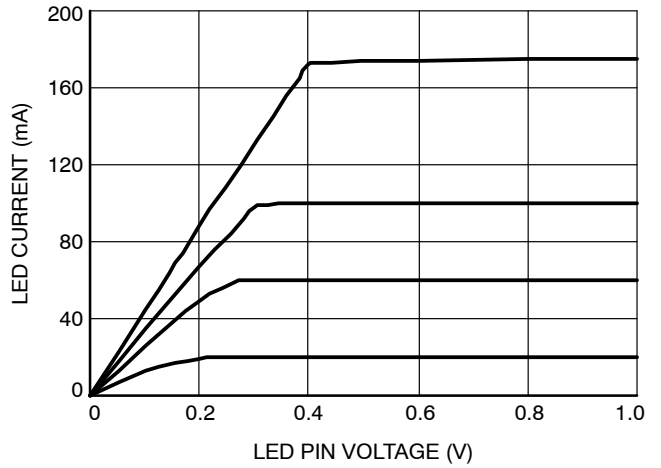

Figure 6. LED Dropout vs. LED Pin Voltage

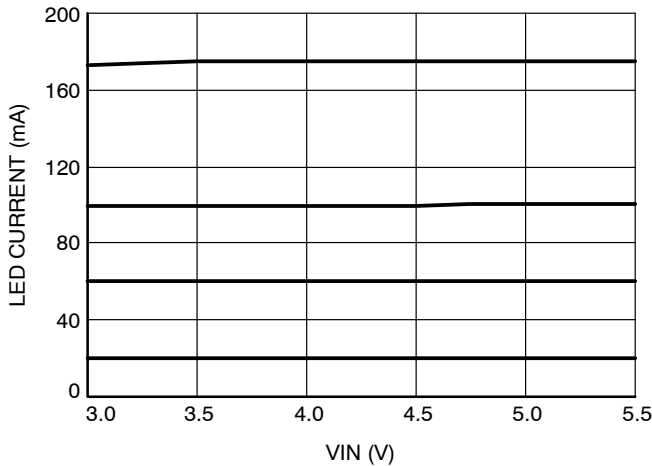

Figure 7. LED Line Regulation

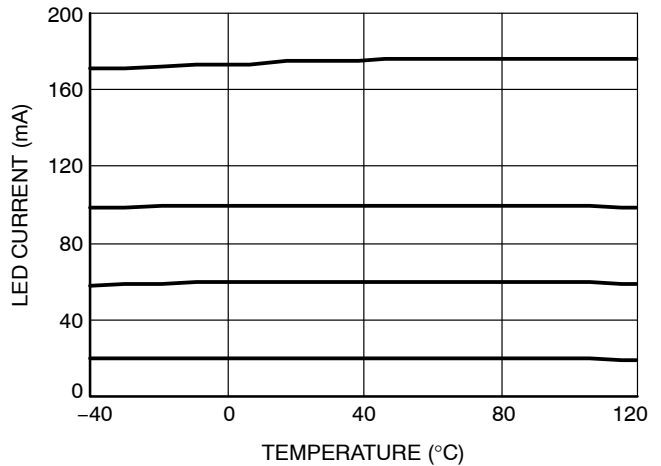
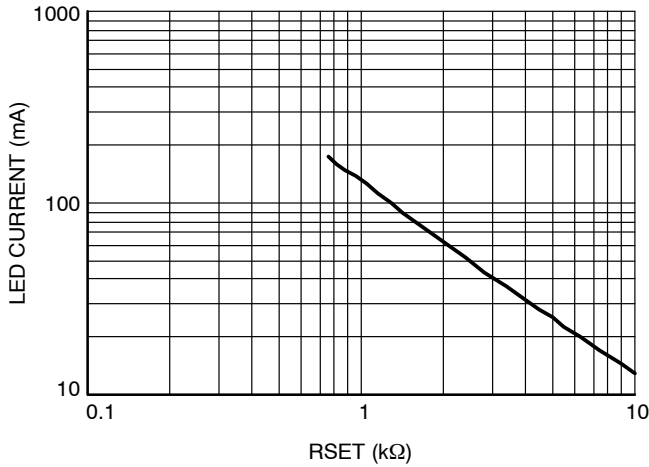

Figure 8. LED Current Change vs. Temperature

**TYPICAL PERFORMANCE CHARACTERISTICS**

(VIN = 5 V, VCC = 5 V, LED FORWARD VOLTAGE = 3.5 V, CIN = 1 MF, TAMB = 25°C UNLESS OTHERWISE SPECIFIED.)



**Figure 9. LED Current vs. RSET Resistor**

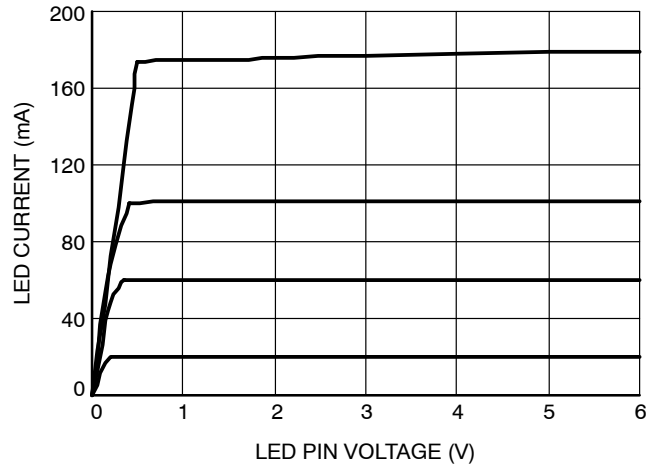

**Figure 10. LED Current vs. LED Pin Voltage**

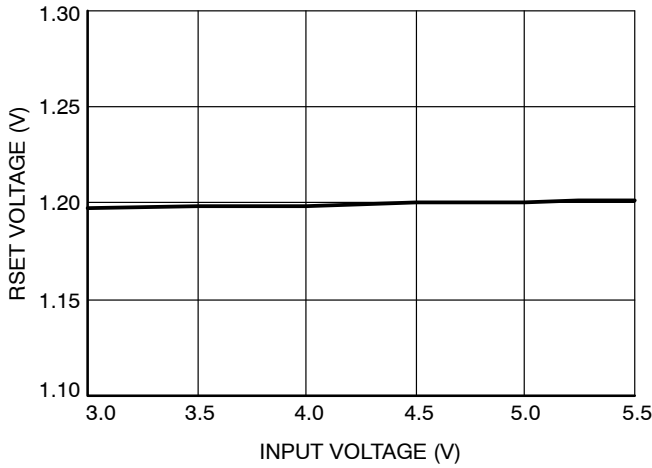

**Figure 11. RSET Pin Voltage vs. Input Voltage**

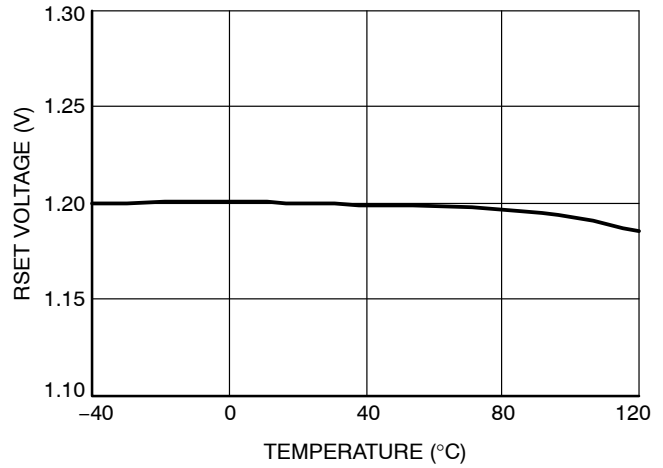

**Figure 12. RSET Pin Voltage vs. Temperature**

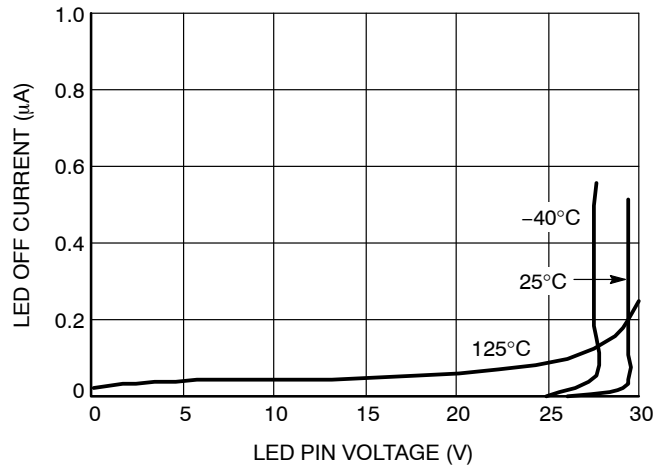

**Figure 13. LED Off Current vs. LED Pin Voltage**

# CAT4104

## TYPICAL PERFORMANCE CHARACTERISTICS

(VIN = 5 V, VCC = 5 V, LED FORWARD VOLTAGE = 3.5 V, CIN = 1 MF, TAMB = 25°C UNLESS OTHERWISE SPECIFIED.)

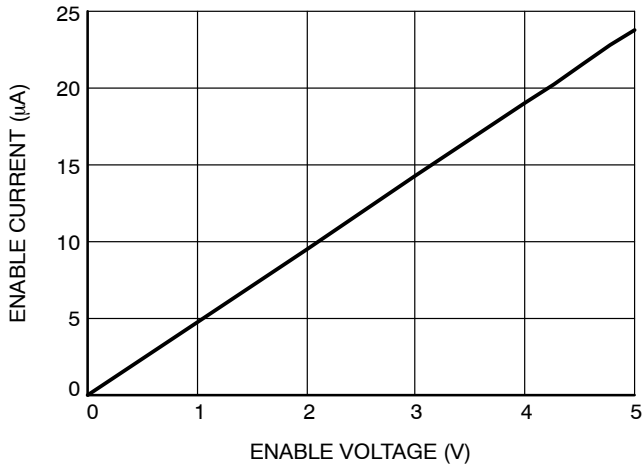

Figure 14. EN/PWM Pull-down Current vs.  $V_{EN/PWM}$

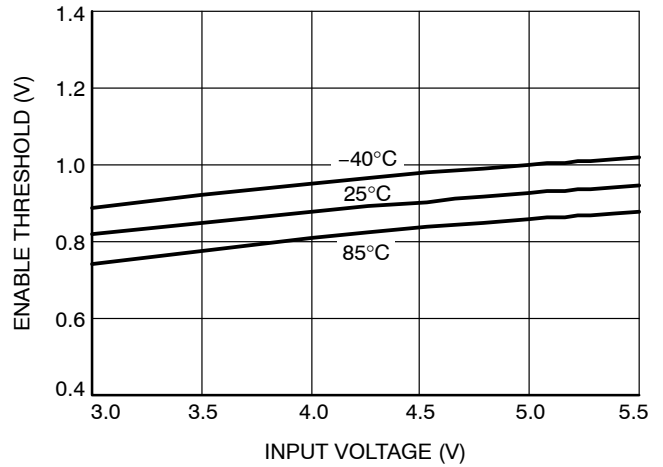

Figure 15. EN/PWM Threshold vs. VIN

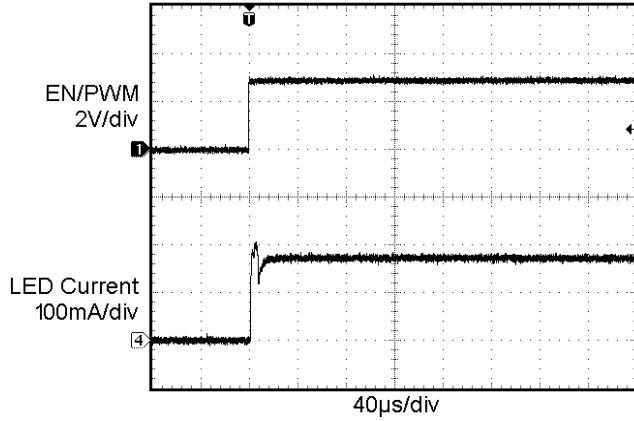

Figure 16. Power Up from Shutdown

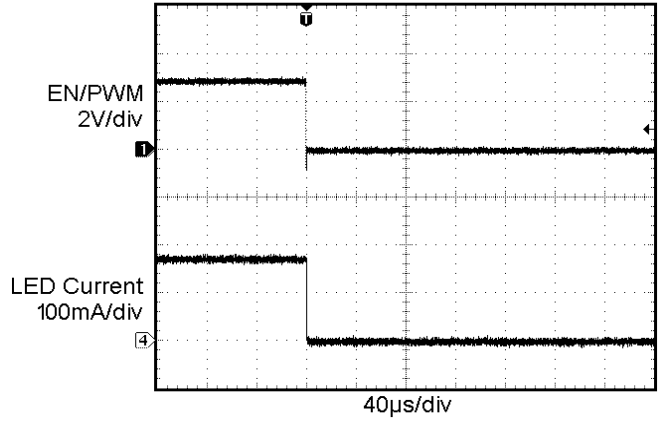

Figure 17. Power Down

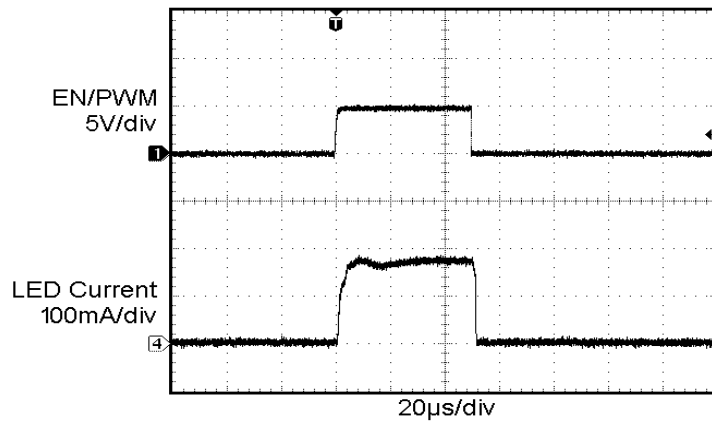

Figure 18. PWM 200 Hz, 1% Duty Cycle

Table 5. PIN DESCRIPTIONS

Name	Pin SOIC 8-Lead	Pin TDFN 8-Lead	Function
LED1	1	1	LED1 cathode terminal
LED2	2	2	LED2 cathode terminal
LED3	3	3	LED3 cathode terminal
LED4	4	4	LED4 cathode terminal
GND	5	5 and TAB	Ground reference
EN/PWM	6	6	Device enable input and PWM control
VIN	7	7	Device supply pin
RSET	8	8	LED current set pin for the LED channels

**PIN FUNCTION**

**VIN** is the supply pin for the device. A small 0.1 μF ceramic bypass capacitor is optional for noisy environments. Whenever the input supply falls below the under-voltage threshold, all LED channels are automatically disabled.

**EN/PWM** is the enable and one wire dimming input for all LED channels. Guaranteed levels of logic high and logic low are set at 1.3 V and 0.4 V respectively. When EN/PWM is initially taken high, the device becomes enabled and all LED currents are set at a gain of 100 times the current in RSET. To place the device into zero current shutdown mode, the EN/PWM pin must be held low for 4 ms typical.

**LED1 to LED4** provide individual regulated currents for each of the LED cathodes. These pins enter a high

impedance zero current state whenever the device is placed in shutdown mode.

**RSET** pin is connected to an external resistor to set the LED channel current. The ground side of the external resistor should be star connected to the GND of the PCB. The pin source current mirrors the current to the LED sinks. The voltage at this pin is regulated to 1.2 V.

**GND** is the ground reference for the device. The pin must be connected to the ground plane on the PCB.

**TAB** (TDFN 8-Lead Only) is the exposed pad underneath the package. For best thermal performance, the tab should be soldered to the PCB and connected to the ground plane.

# CAT4104

## BLOCK DIAGRAM

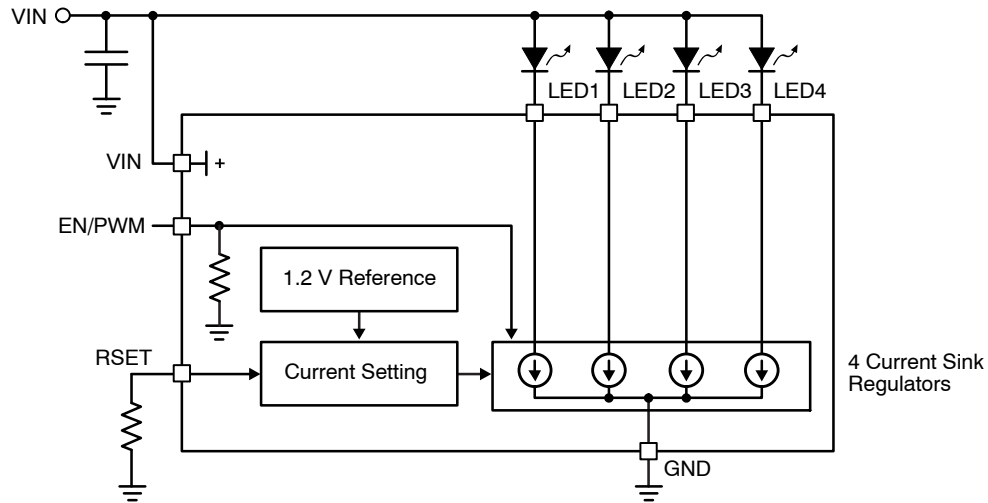

Figure 19. CAT4104 Functional Block Diagram

## BASIC OPERATION

The CAT4104 has four tightly matched current sinks to regulate LED current in each channel. The LED current in the four channels is mirrored from the current flowing through the RSET pin according to the following formula:

$$R(\text{k}\Omega) = 117 \times I (\text{mA})^{-0.978} + 0.05$$

Table 6 shows standard resistor values for RSET and the corresponding LED current.

Table 6. RSET RESISTOR SETTINGS

LED Current [mA]	RSET [kΩ]
20	6.34
60	2.10
100	1.27
175	0.768

Tight current regulation for all channels is possible over a wide range of input voltages and LED voltages due to independent current sensing circuitry on each channel.

Each LED channel needs a minimum of 400 mV headroom to sink constant regulated current up to 175 mA. If the input supply falls below 2 V, the under-voltage lockout circuit disables all LED channels. Any unused LED channels should be left open.

For applications requiring more than 175 mA current, LED channels can be tied together to sink up to a total of 700 mA from the one device.

The LED channels can withstand voltages up to 25 V. This makes the device ideal for driving long strings of high power LEDs from a high voltage source.

**APPLICATION INFORMATION**

**Single 12 V Supply**

The circuit shown in Figure 20 shows how to power the LEDs from a single 12 V supply using the CAT4104. Three external components are needed to create a lower voltage necessary for the VIN pin (below 5.5 V). The resistor R2 and zener diode Z provide a regulated voltage while the quiescent current runs through the N-Channel transistor M. The recommended parts are ON Semiconductor MM3Z6V2 zener diode (in SOD-323 package), and 2N7002L N-Channel transistor (in SOT23).

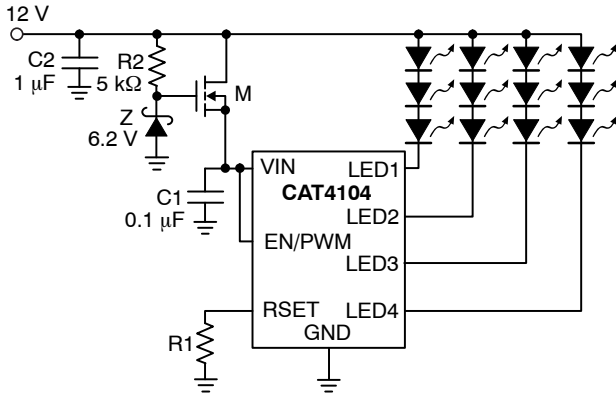

**Figure 20. Single Supply Driving 12 LEDs**

**Daylight Detection**

The circuit in Figure 21 shows how to use CAT4104 in an automatic light sensor application. The light sensor allows the CAT4104 to be enabled during the day and disabled during the night. Two external components are required to configure the part for ambient light detection and conserve power. Resistor R1 sets the bias for the light sensor. The recommended part is Microsemi LX1972 light sensor. For best performance, the LED light should not interfere with the light sensor.

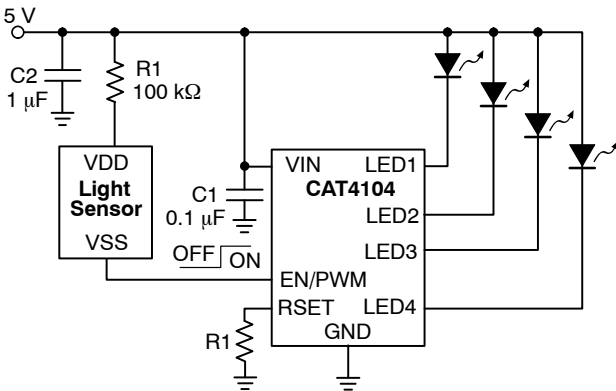

**Figure 21. Daylight Detection**

**Nightlight Detection**

The circuit shown in Figure 22 illustrates how to use the CAT4104 in an automatic night light application. The light sensor allows the CAT4104 to be disabled during the day and enabled during the night. Five external components are needed to properly configure the part for night detection. Resistor R3 limits the quiescent current through the N-Channel transistor M. Resistors R1 and R2 act as a voltage divider to create the required voltage to turn on transistor M, which disables the CAT4104. The recommended parts are ON Semiconductor 2N7002L N-Channel transistor (in SOT23) and the Microsemi LX1972 light sensor. For best performance, the LED light should not interfere with the light sensor.

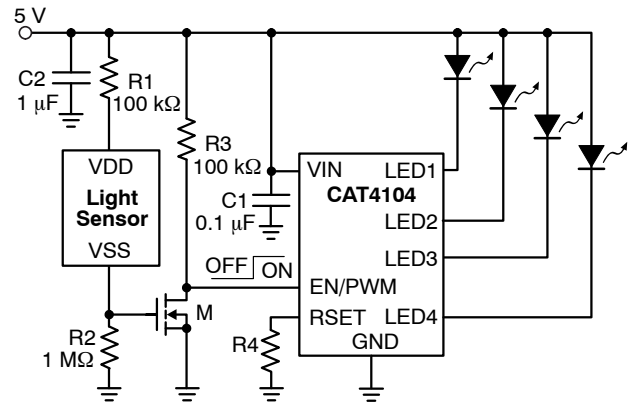

**Figure 22. Nightlight Detection**

**LED Current Derating**

The circuit shown in Figure 23 provides LED temperature derating to avoid over-driving the LED under high ambient temperatures, by reducing the LED current to protect the LED from over-heating. The positive thermo coefficient (PTC) thermistor RPTC is used for temperature sensing and should be located near the LED. As the temperature of RPTC increases, the gate voltage of the MOSFET M1 decreases. This causes the transistor M1 on-resistance to increase which results in a reduction of the LED current. The circuit is powered from a single VCC voltage of 5 V. The recommended parts are Vishay 70°C thermistor PTCSS12T071DTE and ON Semiconductor 2N7002L N-Channel transistor (in SOT23).

The PCB and heatsink for the LED should be designed such that the LED current is constant within the normal temperature range. But as soon as the ambient temperature exceeds a max threshold, the LED current drops to protect the LEDs from overheating.

## CAT4104

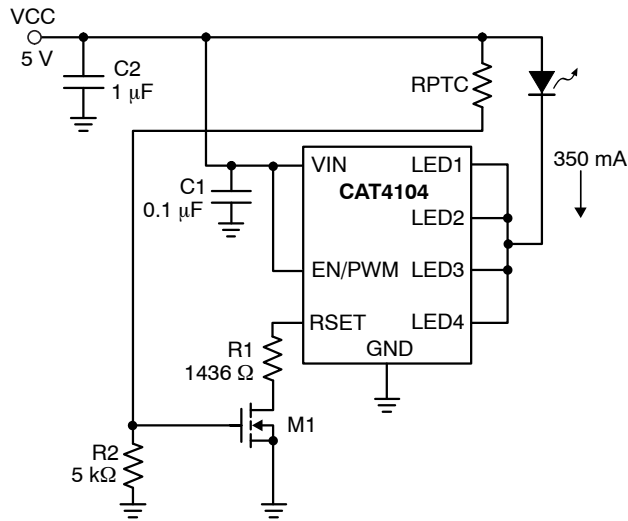

**Figure 23. LED Current Derating**

### Power Dissipation

The power dissipation ( $P_D$ ) of the CAT4104 can be calculated as follows:

$$P_D = (V_{IN} \times I_{IN}) + \Sigma(V_{LEDN} \times I_{LEDN})$$

where  $V_{LEDN}$  is the voltage at the LED pin, and  $I_{LEDN}$  is the LED current. Combinations of high  $V_{LEDN}$  voltage and high ambient temperature can cause the CAT4104 to enter thermal shutdown. In applications where  $V_{LEDN}$  is high, a resistor can be inserted in series with the LED string to lower the power dissipation  $P_D$ .

Thermal dissipation of the junction heat consists primarily of two paths in series. The first path is the junction to the case ( $\theta_{JC}$ ) thermal resistance which is defined by the package style, and the second path is the case to ambient ( $\theta_{CA}$ ) thermal resistance, which is dependent on board layout. The overall junction to ambient ( $\theta_{JA}$ ) thermal resistance is equal to:

$$\theta_{JA} = \theta_{JC} + \theta_{CA}$$

For a given package style and board layout, the operating junction temperature  $T_J$  is a function of the power dissipation  $P_D$ , and the ambient temperature, resulting in the following equation:

$$T_J = T_{AMB} + P_D(\theta_{JC} + \theta_{CA}) = T_{AMB} + P_D \theta_{JA}$$

When mounted on a double-sided printed circuit board with two square inches of copper allocated for “heat spreading”, the resulting  $\theta_{JA}$  is about  $90^\circ\text{C/W}$  for the TDFN-8 package, and  $160^\circ\text{C/W}$  for the SOIC-8 package.

For example, at  $60^\circ\text{C}$  ambient temperature, the maximum power dissipation for the TDFN-8 is calculated as follow:

$$P_{Dmax} = \frac{T_{Jmax} - T_{AMB}}{\theta_{JA}} = \frac{150 - 60}{90} = 1 \text{ W}$$

### Recommended Layout

A small ceramic capacitor should be placed as close as possible to the driver VIN pin. The RSET resistor should have a Kelvin connection to the GND pin of the CAT4104.

The board layout should provide good thermal dissipation through the PCB. In the case of the CAT4104VP2 in the TDFN package, a via can be used to connect the center tab to a large ground plane underneath as shown on Figure 24.

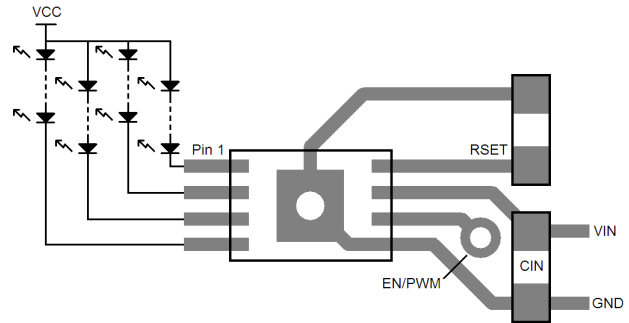

**Figure 24. CAT4104 Recommended Layout**

# CAT4104

## EXAMPLE OF ORDERING INFORMATION (NOTE 6)

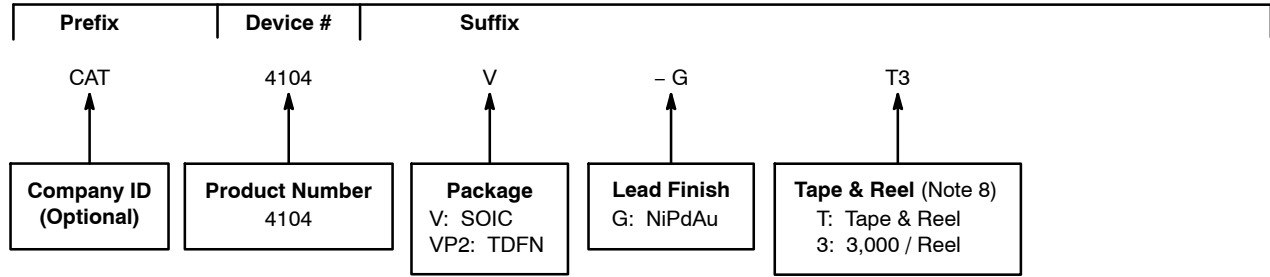

4. All packages are RoHS-compliant (Lead-free, Halogen-free).
5. The standard plated finish is NiPdAu.
6. The device used in the above example is a CAT4104V-GT3 (SOIC, NiPdAu, Tape & Reel, 3,000/Reel).
7. For additional temperature options, please contact your nearest ON Semiconductor Sales office.
8. For information on tape and reel specifications, including part orientation and tape sizes, please refer to our Tape and Reel Packaging Specifications Brochure, BRD8011/D.

# MECHANICAL CASE OUTLINE

## PACKAGE DIMENSIONS

ON Semiconductor®



SCALE 2:1

TDFN8, 2x3, 0.5P  
CASE 511AK  
ISSUE B

DATE 18 MAR 2015

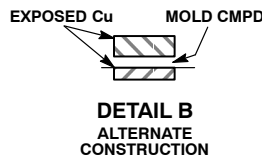
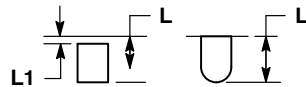
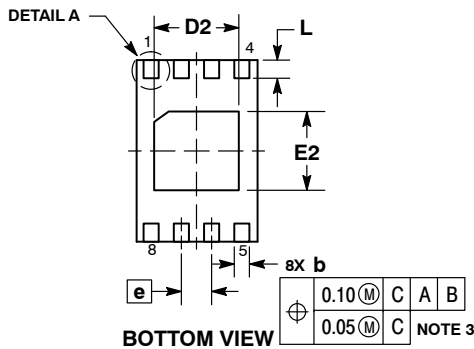
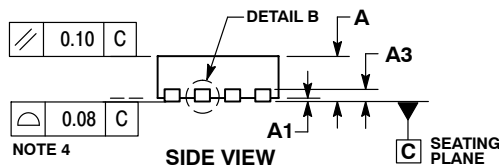
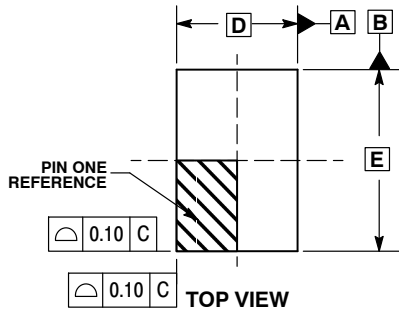

**NOTES:**

1. DIMENSIONING AND TOLERANCING PER ASME Y14.5M, 1994.
2. CONTROLLING DIMENSION: MILLIMETERS.
3. DIMENSION b APPLIES TO PLATED TERMINAL AND IS MEASURED BETWEEN 0.15 AND 0.25MM FROM THE TERMINAL TIP.
4. COPLANARITY APPLIES TO THE EXPOSED PAD AS WELL AS THE TERMINALS.

DIM	MILLIMETERS	
	MIN	MAX
A	0.70	0.80
A1	0.00	0.05
A3	0.20 REF	
b	0.20	0.30
D	2.00 BSC	
D2	1.30	1.50
E	3.00 BSC	
E2	1.20	1.40
e	0.50 BSC	
L	0.20	0.40
L1	---	0.15

**GENERIC MARKING DIAGRAM\***

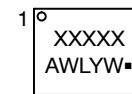

- XXXXX = Specific Device Code
- A = Assembly Location
- WL = Wafer Lot
- Y = Year
- W = Work Week
- = Pb-Free Package

\*This information is generic. Please refer to device data sheet for actual part marking. Pb-Free indicator, "G" or microdot "▪", may or may not be present.

**RECOMMENDED SOLDERING FOOTPRINT\***

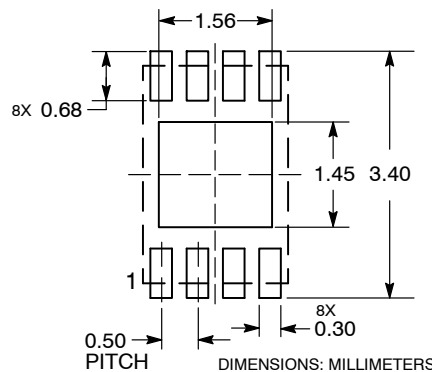

\*For additional information on our Pb-Free strategy and soldering details, please download the ON Semiconductor Soldering and Mounting Techniques Reference Manual, SOLDERRM/D.

<b>DOCUMENT NUMBER:</b>	<b>98AON34336E</b>	Electronic versions are uncontrolled except when accessed directly from the Document Repository. Printed versions are uncontrolled except when stamped "CONTROLLED COPY" in red.
<b>DESCRIPTION:</b>	<b>TDFN8, 2X3, 0.5P</b>	<b>PAGE 1 OF 1</b>

ON Semiconductor and ON are trademarks of Semiconductor Components Industries, LLC dba ON Semiconductor or its subsidiaries in the United States and/or other countries. ON Semiconductor reserves the right to make changes without further notice to any products herein. ON Semiconductor makes no warranty, representation or guarantee regarding the suitability of its products for any particular purpose, nor does ON Semiconductor assume any liability arising out of the application or use of any product or circuit, and specifically disclaims any and all liability, including without limitation special, consequential or incidental damages. ON Semiconductor does not convey any license under its patent rights nor the rights of others.

**MECHANICAL CASE OUTLINE**  
**PACKAGE DIMENSIONS**



**SOIC-8, 150 mils**  
**CASE 751BD**  
**ISSUE O**

DATE 19 DEC 2008

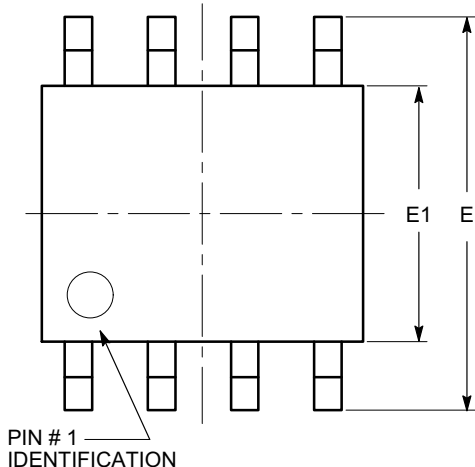

**TOP VIEW**

SYMBOL	MIN	NOM	MAX
A	1.35		1.75
A1	0.10		0.25
b	0.33		0.51
c	0.19		0.25
D	4.80		5.00
E	5.80		6.20
E1	3.80		4.00
e	1.27 BSC		
h	0.25		0.50
L	0.40		1.27
$\theta$	0°		8°

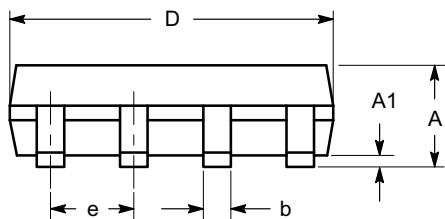

**SIDE VIEW**

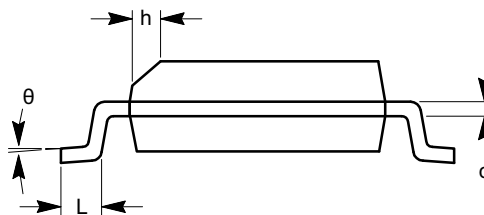

**END VIEW**

**Notes:**

- (1) All dimensions are in millimeters. Angles in degrees.
- (2) Complies with JEDEC MS-012.

<b>DOCUMENT NUMBER:</b>	<b>98AON34272E</b>	Electronic versions are uncontrolled except when accessed directly from the Document Repository. Printed versions are uncontrolled except when stamped "CONTROLLED COPY" in red.
<b>DESCRIPTION:</b>	<b>SOIC 8, 150 MILS</b>	<b>PAGE 1 OF 1</b>

onsemi and onsemi are trademarks of Semiconductor Components Industries, LLC dba onsemi or its subsidiaries in the United States and/or other countries. onsemi reserves the right to make changes without further notice to any products herein. onsemi makes no warranty, representation or guarantee regarding the suitability of its products for any particular purpose, nor does onsemi assume any liability arising out of the application or use of any product or circuit, and specifically disclaims any and all liability, including without limitation special, consequential or incidental damages. onsemi does not convey any license under its patent rights nor the rights of others.

**onsemi**, **Onsemi**, and other names, marks, and brands are registered and/or common law trademarks of Semiconductor Components Industries, LLC dba "**onsemi**" or its affiliates and/or subsidiaries in the United States and/or other countries. **onsemi** owns the rights to a number of patents, trademarks, copyrights, trade secrets, and other intellectual property. A listing of **onsemi**'s product/patent coverage may be accessed at [www.onsemi.com/site/pdf/Patent-Marking.pdf](http://www.onsemi.com/site/pdf/Patent-Marking.pdf). **onsemi** reserves the right to make changes at any time to any products or information herein, without notice. The information herein is provided "as-is" and **onsemi** makes no warranty, representation or guarantee regarding the accuracy of the information, product features, availability, functionality, or suitability of its products for any particular purpose, nor does **onsemi** assume any liability arising out of the application or use of any product or circuit, and specifically disclaims any and all liability, including without limitation special, consequential or incidental damages. Buyer is responsible for its products and applications using **onsemi** products, including compliance with all laws, regulations and safety requirements or standards, regardless of any support or applications information provided by **onsemi**. "Typical" parameters which may be provided in **onsemi** data sheets and/or specifications can and do vary in different applications and actual performance may vary over time. All operating parameters, including "Typicals" must be validated for each customer application by customer's technical experts. **onsemi** does not convey any license under any of its intellectual property rights nor the rights of others. **onsemi** products are not designed, intended, or authorized for use as a critical component in life support systems or any FDA Class 3 medical devices or medical devices with a same or similar classification in a foreign jurisdiction or any devices intended for implantation in the human body. Should Buyer purchase or use **onsemi** products for any such unintended or unauthorized application, Buyer shall indemnify and hold **onsemi** and its officers, employees, subsidiaries, affiliates, and distributors harmless against all claims, costs, damages, and expenses, and reasonable attorney fees arising out of, directly or indirectly, any claim of personal injury or death associated with such unintended or unauthorized use, even if such claim alleges that **onsemi** was negligent regarding the design or manufacture of the part. **onsemi** is an Equal Opportunity/Affirmative Action Employer. This literature is subject to all applicable copyright laws and is not for resale in any manner.

## ADDITIONAL INFORMATION

### TECHNICAL PUBLICATIONS:

Technical Library: [www.onsemi.com/design/resources/technical-documentation](http://www.onsemi.com/design/resources/technical-documentation)  
onsemi Website: [www.onsemi.com](http://www.onsemi.com)

### ONLINE SUPPORT: [www.onsemi.com/support](http://www.onsemi.com/support)

For additional information, please contact your local Sales Representative at [www.onsemi.com/support/sales](http://www.onsemi.com/support/sales)



## Looking for pricing, stock, or lifecycle information?

Click below to explore more details on WIN SOURCE:

- ⊖ [View CAT4104V-GT3 on WIN SOURCE](#)
- ⊖ [ON Semiconductor Information](#)

## Optimize Your Supply Chain with WIN SOURCE Solutions

- ✓ Global Sourcing Solution
- ✓ Obsolete Management
- ✓ Cost Control Management
- ✓ Shortage Management
- ✓ Alternative Solution
- ✓ Excess Inventory Management