



**THE DATASHEET OF  
AM26LV32CDR**



## AM26LV32 Low-Voltage, High-Speed Quadruple Differential Line Receiver

### 1 Features

- Switching Rates Up to 32 MHz
- Operates From Single 3.3-V Supply
- Ultra-Low Power Dissipation: 27 mW Typical
- Open-Circuit, Short-Circuit, and Terminated Fail-Safe
- $-0.3\text{-V}$  to  $5.5\text{-V}$  Common-Mode Range With  $\pm 200\text{-mV}$  Sensitivity
- Accepts  $5\text{-V}$  Logic Inputs With  $3.3\text{-V}$   $V_{CC}$
- Input Hysteresis: 50 mV Typical
- 235 mW With Four Receivers at 32 MHz
- Pin-to-Pin Compatible With AM26C32 and AM26LS32

### 2 Applications

- High-Reliability Automotive Applications
- Factory Automation
- ATM and Cash Counters
- Smart Grid
- AC and Servo Motor Drives

### 3 Description

The AM26LV32 device is a BiCMOS, quadruple differential line receiver with 3-state outputs, which is designed to be similar to the TIA/EIA-422-B and ITU Recommendation V.11 receivers with reduced common-mode voltage range due to reduced supply voltage.

The device is optimized for balanced bus transmission at switching rates up to 32 MHz. The enable function is common to all four receivers and offers a choice of active-high or active-low inputs. The 3-state outputs permit connection directly to a bus-organized system. Each device features high input impedance, input hysteresis for increased noise immunity, and input sensitivity of  $\pm 200$  mV over a common-mode input voltage range from  $-0.3$  V to  $5.5$  V. When the inputs are open-circuit, the outputs are in the high logic state.

The AM26LV32C is characterized for operation from  $0^{\circ}\text{C}$  to  $70^{\circ}\text{C}$ . The AM26LV32I is characterized for operation from  $-45^{\circ}\text{C}$  to  $85^{\circ}\text{C}$ .

#### Device Information<sup>(1)</sup>

PART NUMBER	PACKAGE	BODY SIZE (NOM)
AM26LV32D	SOIC (16)	9.90 mm × 3.90 mm
AM26LV32NS	SO (16)	10.20 mm × 5.30 mm

(1) For all available packages, see the orderable addendum at the end of the data sheet.

#### Logic Diagram (Positive Logic)

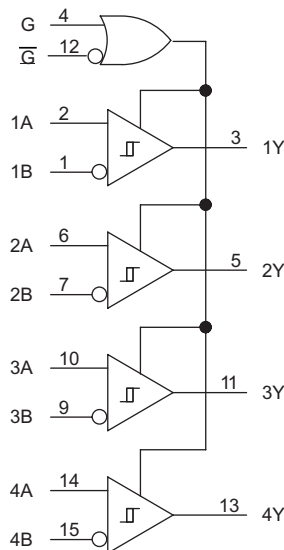

## Table of Contents

<b>1 Features</b> .....	<b>1</b>	8.3 Feature Description .....	<b>9</b>
<b>2 Applications</b> .....	<b>1</b>	8.4 Device Functional Modes .....	<b>10</b>
<b>3 Description</b> .....	<b>1</b>	<b>9 Application and Implementation</b> .....	<b>17</b>
<b>4 Revision History</b> .....	<b>2</b>	9.1 Application Information .....	<b>17</b>
<b>5 Pin Configuration and Functions</b> .....	<b>3</b>	9.2 Typical Application .....	<b>17</b>
<b>6 Specifications</b> .....	<b>4</b>	<b>10 Power Supply Recommendations</b> .....	<b>19</b>
6.1 Absolute Maximum Ratings .....	<b>4</b>	<b>11 Layout</b> .....	<b>19</b>
6.2 ESD Ratings .....	<b>4</b>	11.1 Layout Guidelines .....	<b>19</b>
6.3 Recommended Operating Conditions .....	<b>4</b>	11.2 Layout Example .....	<b>19</b>
6.4 Thermal Information .....	<b>4</b>	<b>12 Device and Documentation Support</b> .....	<b>20</b>
6.5 Electrical Characteristics .....	<b>5</b>	12.1 Receiving Notification of Documentation Updates .....	<b>20</b>
6.6 Switching Characteristics .....	<b>5</b>	12.2 Community Resources .....	<b>20</b>
6.7 Typical Characteristics .....	<b>6</b>	12.3 Trademarks .....	<b>20</b>
<b>7 Parameter Measurement Information</b> .....	<b>7</b>	12.4 Electrostatic Discharge Caution .....	<b>20</b>
<b>8 Detailed Description</b> .....	<b>9</b>	12.5 Glossary .....	<b>20</b>
8.1 Overview .....	<b>9</b>	<b>13 Mechanical, Packaging, and Orderable Information</b> .....	<b>20</b>
8.2 Functional Block Diagram .....	<b>9</b>		

## 4 Revision History

NOTE: Page numbers for previous revisions may differ from page numbers in the current version.

<b>Changes from Revision F (November 2016) to Revision G</b>	<b>Page</b>
• Changed the MAX value of $t_{sk(p)}$ From: 6 ns To: 14 ns in the <i>Switching Characteristics</i> table .....	<b>5</b>
• Changed the MAX value of $t_{sk(o)}$ From: 6 ns To: 14 ns in the <i>Switching Characteristics</i> table .....	<b>5</b>

<b>Changes from Revision E (June 2005) to Revision F</b>	<b>Page</b>
• Added <i>ESD Ratings</i> table, <i>Thermal Information</i> table, <i>Feature Description</i> section, <i>Device Functional Modes</i> , <i>Application and Implementation</i> section, <i>Power Supply Recommendations</i> section, <i>Layout</i> section, <i>Device and Documentation Support</i> section, and <i>Mechanical, Packaging, and Orderable Information</i> section .....	<b>1</b>
• Deleted MB570 from <i>Features</i> list .....	<b>1</b>
• Deleted <i>Ordering Information</i> table; see <i>Mechanical, Packaging, and Orderable Information</i> at the end of the data sheet. <b>1</b>	<b>1</b>
• Deleted Lead temperature (260°C maximum) from <i>Absolute Maximum Ratings</i> table .....	<b>4</b>
• Changed Package thermal impedance, $R_{\theta JA}$ , values in <i>Thermal Information</i> table From: 73°C To: 72.9°C (D) and From: 64°C To: 74°C (NS) .....	<b>4</b>

## 5 Pin Configuration and Functions

**D and NS Package  
16-Pin SOIC and SO  
Top View**

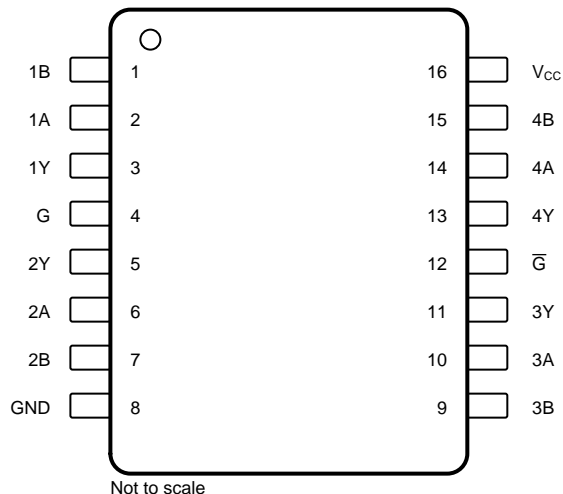

**Pin Functions**

PIN		I/O	DESCRIPTION
NAME	NO.		
1A	2	I	RS422, RS485 differential input (noninverting)
1B	1	I	RS422, RS485 differential input (inverting)
1Y	3	O	Logic level output
2A	6	I	RS422, RS485 differential input (noninverting)
2B	7	I	RS422, RS485 differential input (inverting)
2Y	5	O	Logic level output
3A	10	I	RS422, RS485 differential input (noninverting)
3B	9	I	RS422, RS485 differential input (inverting)
3Y	11	O	Logic level output
4A	14	I	RS422, RS485 differential input (noninverting)
4B	15	I	RS422, RS485 differential input (inverting)
4Y	13	O	Logic level output
$\bar{G}$	12	I	Active-low select
G	4	I	Active-high select
GND	8	—	Ground
V <sub>CC</sub>	16	—	Power supply

## 6 Specifications

### 6.1 Absolute Maximum Ratings

Over operating free-air temperature range (unless otherwise noted)<sup>(1)</sup>

	MIN	MAX	UNIT
Supply voltage, $V_{CC}$ <sup>(2)</sup>	-0.3	6	V
Input voltage, $V_I$	-4	8	V
Differential input voltage, $V_{ID}$ <sup>(3)</sup>		±12	V
Enable input voltage	-0.3	6	V
Output voltage, $V_O$	-0.3	6	V
Maximum output current, $I_O$		±25	mA
Storage temperature, $T_{stg}$	-65	150	°C

- (1) Stresses beyond those listed under *Absolute Maximum Ratings* may cause permanent damage to the device. These are stress ratings only, which do not imply functional operation of the device at these or any other conditions beyond those indicated under *Recommended Operating Conditions*. Exposure to absolute-maximum-rated conditions for extended periods may affect device reliability.
- (2) All voltage values are with respect to the GND terminal.
- (3) Differential input voltage is measured at the noninverting input with respect to the corresponding inverting input.

### 6.2 ESD Ratings

		VALUE	UNIT
$V_{(ESD)}$ Electrostatic discharge	Human-body model (HBM), per ANSI/ESDA/JEDEC JS-001 <sup>(1)</sup>	±500	V
	Charged-device model (CDM), per JEDEC specification JESD22-C101 <sup>(2)</sup>	±500	

- (1) JEDEC document JEP155 states that 500-V HBM allows safe manufacturing with a standard ESD control process.
- (2) JEDEC document JEP157 states that 250-V CDM allows safe manufacturing with a standard ESD control process.

### 6.3 Recommended Operating Conditions

over operating free-air temperature range (unless otherwise noted)

		MIN	NOM	MAX	UNIT
Supply voltage, $V_{CC}$		3	3.3	3.6	V
High-level input voltage, $V_{IH(EN)}$		2			V
Low-level input voltage, $V_{IL(EN)}$				0.8	V
Common-mode input voltage, $V_{IC}$		-0.3		5.5	V
Differential input voltage, $V_{ID}$				±5.8	V
High-level output current, $I_{OH}$				-5	mA
Low-level output current, $I_{OL}$				5	mA
Operating free-air temperature, $T_A$	AM26LV32C	0		70	°C
	AM26LV32I	-40		85	

### 6.4 Thermal Information

THERMAL METRIC <sup>(1)(2)</sup>		AM26LV32		UNIT
		D (SOIC)	NS (SO)	
		16 PINS	16 PINS	
$R_{\theta JA}$	Junction-to-ambient thermal resistance	72.9	74	°C/W
$R_{\theta JC(top)}$	Junction-to-case (top) thermal resistance	32.4	31.1	°C/W
$R_{\theta JB}$	Junction-to-board thermal resistance	30.4	34.8	°C/W
$\Psi_{JT}$	Junction-to-top characterization parameter	5.4	5.1	°C/W
$\Psi_{JB}$	Junction-to-board characterization parameter	30.1	34.5	°C/W

- (1) For more information about traditional and new thermal metrics, see the [Semiconductor and IC Package Thermal Metrics](#) application report.
- (2) The package thermal impedance is calculated in accordance with JESD 51.

## 6.5 Electrical Characteristics

over operating free-air temperature range (unless otherwise noted)

PARAMETER	TEST CONDITIONS	MIN	TYP <sup>(1)</sup>	MAX	UNIT
V <sub>IT+</sub>	Differential input high-threshold voltage			0.2	V
V <sub>IT-</sub>	Differential input low-threshold voltage	-0.2			V
V <sub>IK</sub>	Enable input clamp voltage	I <sub>I</sub> = -18 mA	-0.8	-1.5	V
V <sub>OH</sub>	High-level output voltage	V <sub>ID</sub> = 200 mV, I <sub>OH</sub> = -5 mA	2.4	3.2	V
V <sub>OL</sub>	Low-level output voltage	V <sub>ID</sub> = 200 mV, I <sub>OH</sub> = 5 mA	0.17	0.5	V
I <sub>OZ</sub>	High-impedance-state output current	V <sub>O</sub> = 0 to V <sub>CC</sub>		±50	µA
I <sub>IH(E)</sub>	High-level enable input current	V <sub>CC</sub> = 0 or 3 V, V <sub>I</sub> = 5.5 V		10	µA
I <sub>IL(E)</sub>	Low-level enable input current	V <sub>CC</sub> = 3.6 V, V <sub>I</sub> = 0 V		-10	µA
r <sub>i</sub>	Input resistance		7	12	kΩ
I <sub>I</sub>	Input current	V <sub>I</sub> = 5.5 V or -0.3 V, all other inputs GND		±700	µA
I <sub>CC</sub>	Supply current	V <sub>I(E)</sub> = V <sub>CC</sub> or GND, no load, line inputs open	8	17	mA
C <sub>pd</sub>	Power dissipation capacitance <sup>(2)</sup>	One channel	150		pF

(1) All typical values are at V<sub>CC</sub> = 3.3 V and T<sub>A</sub> = 25°C.

(2) C<sub>pd</sub> determines the no-load dynamic current: I<sub>S</sub> = C<sub>pd</sub> × V<sub>CC</sub> × f + I<sub>CC</sub>.

## 6.6 Switching Characteristics

over operating free-air temperature range (unless otherwise noted)

PARAMETER	TEST CONDITIONS	MIN	TYP	MAX	UNIT	
t <sub>PLH</sub>	Propagation delay time, low- to high-level output	See <a href="#">Figure 4</a>	8	16	20	ns
t <sub>PHL</sub>	Propagation delay time, high- to low-level output	See <a href="#">Figure 4</a>	8	16	20	ns
t <sub>t</sub>	Transition time (t <sub>r</sub> or t <sub>f</sub> )	See <a href="#">Figure 4</a>	5			ns
t <sub>PZH</sub>	Output-enable time to high level	See <a href="#">Figure 5</a>	17	40		ns
t <sub>PZL</sub>	Output-enable time to low level	See <a href="#">Figure 6</a>	10	40		ns
t <sub>PHZ</sub>	Output-disable time from high level	See <a href="#">Figure 5</a>	20	40		ns
t <sub>PLZ</sub>	Output-disable time from low level	See <a href="#">Figure 6</a>	16	40		ns
t <sub>sk(p)</sub> <sup>(1)</sup>	Pulse skew		4	14		ns
t <sub>sk(o)</sub> <sup>(2)</sup>	Pulse skew		4	14		ns
t <sub>sk(pp)</sub> <sup>(3)</sup>	Pulse skew (device to device)		6	9		ns

(1) t<sub>sk(p)</sub> is |t<sub>PLH</sub> - t<sub>PHL</sub>| of each channel of the same device.

(2) t<sub>sk(o)</sub> is the maximum difference in propagation delay times between any two channels of the same device switching in the same direction.

(3) t<sub>sk(pp)</sub> is the maximum difference in propagation delay times between any two channels of any two devices switching in the same direction.

### 6.7 Typical Characteristics

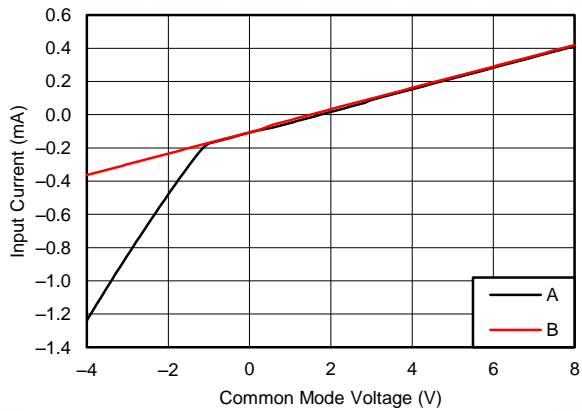

Figure 1. RS422 Port Current vs Common-Mode Voltage

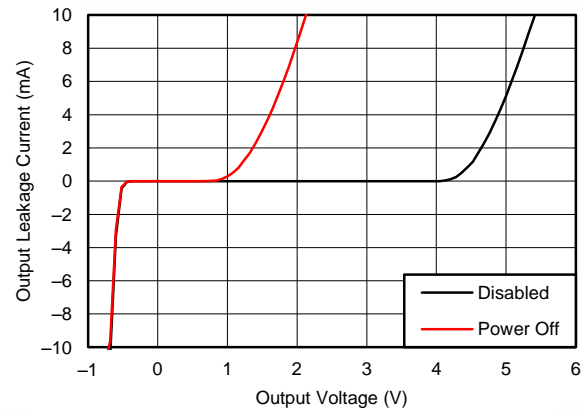

Figure 2. Output Y Leakage Current vs Output Y Voltage

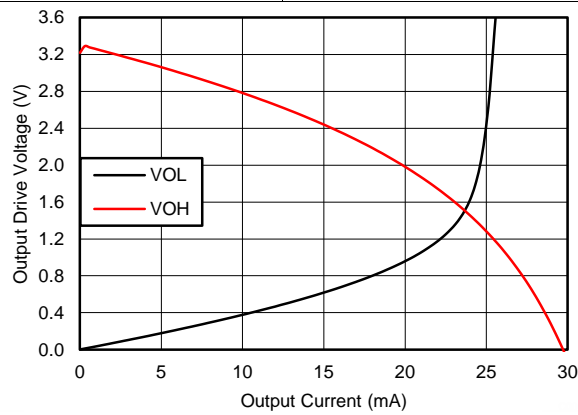
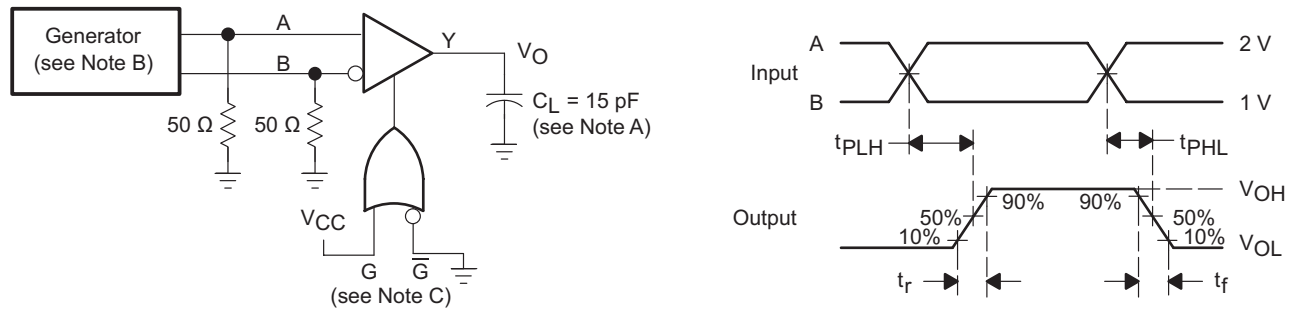

Figure 3. Output Y Drive Voltage vs Output Y Current

## 7 Parameter Measurement Information



- $C_L$  includes probe and jig capacitance.
- The input pulse is supplied by a generator having the following characteristics:  $Z_O = 50 \Omega$ ,  $PRR = 10 \text{ MHz}$ ,  $t_r$  and  $t_f$  (10% to 90%)  $\leq 2 \text{ ns}$ , 50% duty cycle.
- To test the active-low enable  $\overline{G}$ , ground G and apply an inverted waveform  $\overline{G}$ .

**Figure 4.  $t_{PLH}$  and  $t_{PHL}$  Test Circuit and Voltage Waveforms**

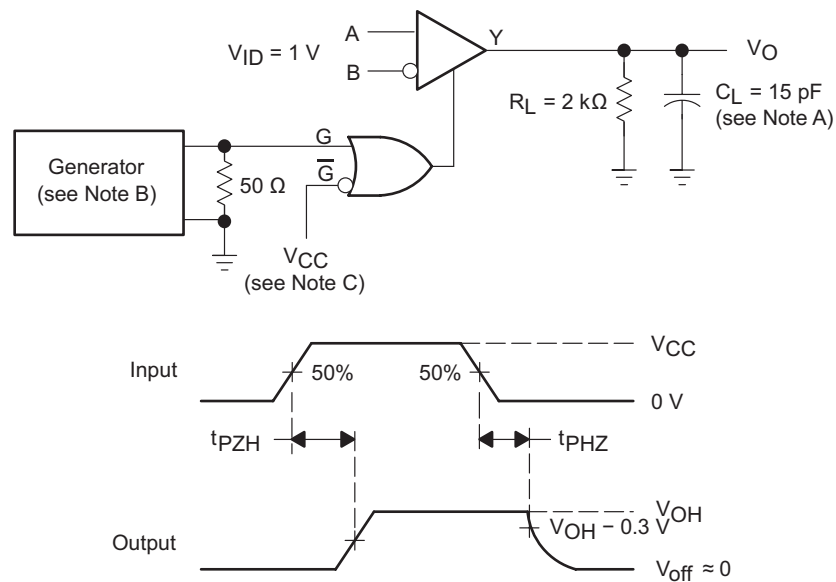

- $C_L$  includes probe and jig capacitance.
- The input pulse is supplied by a generator having the following characteristics:  $Z_O = 50 \Omega$ ,  $PRR = 10 \text{ MHz}$ ,  $t_r$  and  $t_f$  (10% to 90%)  $\leq 2 \text{ ns}$ , 50% duty cycle.
- To test the active-low enable  $\overline{G}$ , ground G and apply an inverted waveform  $\overline{G}$ .

**Figure 5.  $t_{PZH}$  and  $t_{PHZ}$  Test Circuit and Voltage Waveforms**

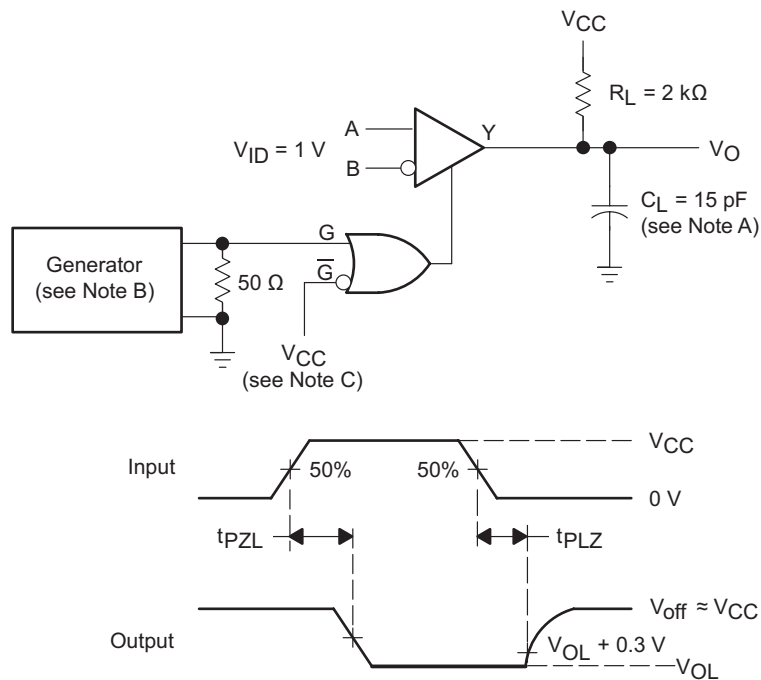
**Parameter Measurement Information (continued)**

- $C_L$  includes probe and jig capacitance.
- The input pulse is supplied by a generator having the following characteristics:  $Z_O = 50 \Omega$ , PRR = 10 MHz,  $t_r$  and  $t_f$  (10% to 90%)  $\leq 2$  ns, 50% duty cycle.
- To test the active-low enable  $\overline{G}$ , ground G and apply an inverted waveform  $\overline{G}$ .

**Figure 6.  $t_{PZL}$  and  $t_{PLZ}$  Test Circuit and Voltage Waveforms**

## 8 Detailed Description

### 8.1 Overview

The AM26LV32 device is a quadruple differential line receiver that meets the necessary requirements for NSI TIA/EIA-422-B, TIA/EIA-423-B, and ITU Recommendation V.10 and V.11. This device allows a low-power or low-voltage MCU to interface with heavy machinery, subsystems, and other devices through long wires of up to 1000 m, giving any design a reliable and easy-to-use connection. As with any RS422 interface, the AM26LV32 works in a differential voltage range, which enables very good signal integrity.

### 8.2 Functional Block Diagram

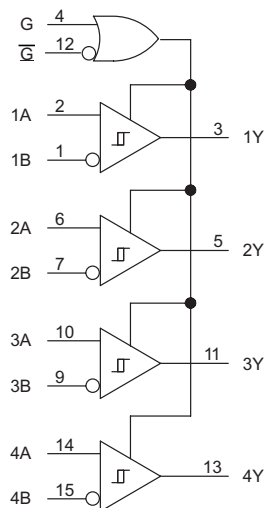
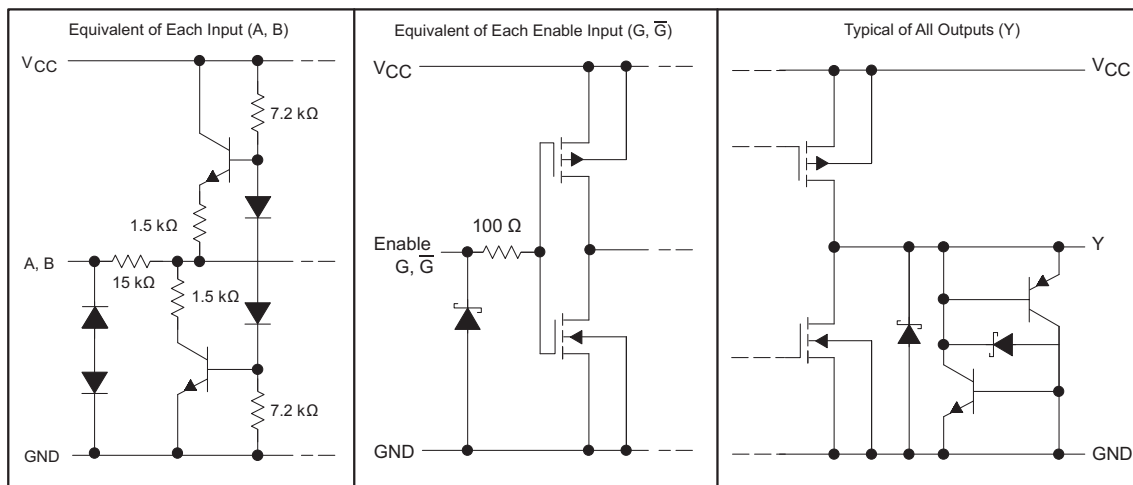

Figure 7. Logic Diagram (Positive Logic)

### 8.3 Feature Description

The device can be configured using the G and G-bar logic inputs to select receiver output. The high voltage or logic 1 on the G pin allows the device to operate on an active-high, and having a low voltage or logic 0 on the G-bar enables active-low operation. These are simple ways to configure the logic to match that of the receiving or transmitting controller or microprocessor.



Copyright © 2016, Texas Instruments Incorporated

Figure 8. Schematics of Equivalent Inputs and Outputs

## 8.4 Device Functional Modes

The receivers implemented in these RS422 devices can be configured using the G and  $\overline{G}$  logic pins to be enabled or disabled. This allows the option to ignore or filter out transmissions as desired. [Table 1](#) lists the function of each receiver.

**Table 1. Function Table (Each Receiver)**

DIFFERENTIAL INPUT	ENABLES		OUTPUT <sup>(1)</sup>
	G	$\overline{G}$	
$V_{ID} \geq 0.2 \text{ V}$	H	X	H
	X	L	H
$-0.2 \text{ V} < V_{ID} < 0.2 \text{ V}$	H	X	?
	X	L	?
$V_{ID} \leq -0.2 \text{ V}$	H	X	L
	X	L	L
Open, shorted, or terminated <sup>(2)</sup>	H	X	H
	X	L	H
X	L	H	Z

(1) H = high level, L = low level, X = irrelevant, Z = high impedance (off), ? = indeterminate

(2) See [Application and Implementation](#) section

### 8.4.1 Fail-Safe Conditions

The AM26LV32 is a quadruple differential line receiver that is designed to function properly when appropriately connected to active drivers. Applications do not always have ideal situations where all bits are being used, the receiver inputs are never left floating, and fault conditions do not exist. In actuality, most applications have the capability to either place the drivers in a high-impedance mode or power down the drivers altogether, and cables may be purposely (or inadvertently) disconnected, both of which lead to floating receiver inputs. Furthermore, even though measures are taken to avoid fault conditions like a short between the differential signals, this does occur. The AM26LV32 device has an internal fail-safe circuitry which prevents the device from putting an unknown voltage signal at the receiver outputs. In the following three cases, a high-state is produced at the respective output:

1. Open fail-safe: Unused input pins are left open. Do not tie unused pins to ground or any other voltage. Internal circuitry places the output in the high state.
2. 100- $\Omega$  terminated fail-safe: Disconnected cables, drivers in high-impedance state, or powered-down drivers does not cause the AM26LV32 to malfunction. The outputs remain in a high state under these conditions. When the drivers are either turned-off or placed into the high-impedance state, the receiver input may still be able to pick up noise due to the cable acting as an antenna. To avoid having a large differential voltage being generated, the use of twisted-pair cable induces the noise as a common-mode signal and is rejected.
3. Shorted fail-safe: Fault conditions that short the differential input pairs together does not cause incorrect data at the outputs. A differential voltage ( $V_{ID}$ ) of 0 V forces a high state at the outputs. Shorted fail-safe, however, is not supported across the recommended common-mode input voltage ( $V_{IC}$ ) range. An unwanted state can be induced to all outputs when an input is shorted and is biased with a voltage between  $-0.3 \text{ V}$  and  $+5.5 \text{ V}$ . The shorted fail-safe circuitry functions properly when an input is shorted, but with no external common-mode voltage applied.

### 8.4.2 Fail-Safe Precautions

The internal fail-safe circuitry was designed such that the input common-mode ( $V_{IC}$ ) and differential ( $V_{ID}$ ) voltages must be observed. To ensure the outputs of unused or inactive receivers remain in a high state when the inputs are open-circuited, shorted, or terminated, extra precaution must be taken on the active signal. In applications where the drivers are placed in a high-impedance mode or are powered-down, TI recommends that for 1, 2, or 3 active receiver inputs, the low-level input voltage ( $V_{IL}$ ) must be greater than 0.4 V. As in all data transmission applications, it is necessary to provide a return ground path between the two remote grounds (driver and receiver ground references) to avoid ground differences. [Table 2](#) and [Figure 9](#) through [Figure 11](#) are examples of active input voltages with their respective waveforms and the effect each have on unused or inactive outputs. Note that the active receivers behave as expected, regardless of the input levels.

Table 2. Active Receiver Inputs vs Outputs

1, 2, OR 3 ACTIVE INPUTS			SEE FIGURE	1, 2, OR 3 ACTIVE OUTPUTS	3, 2, OR 1 UNUSED OR INACTIVE OUTPUTS
$V_{IL}$	$V_{ID}$	$V_{IC}$			
900 mV	200 mV	1 V	Figure 9	Known state	High state
-100 mV	200 mV	0 V	Figure 10	Known state	?
600 mV	800 mV	1 V	Figure 11	Known state	High state
0 mV	800 mV	400 mV	Figure 12	Known state	?

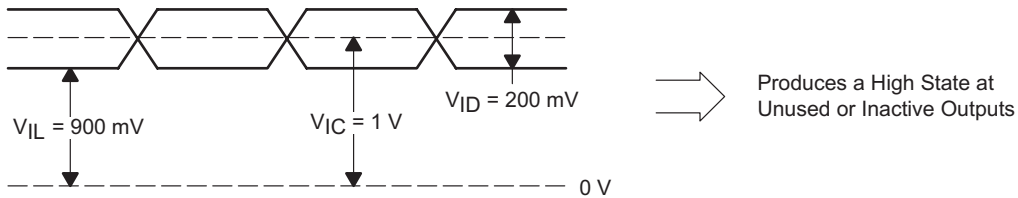

Figure 9. Waveform 1

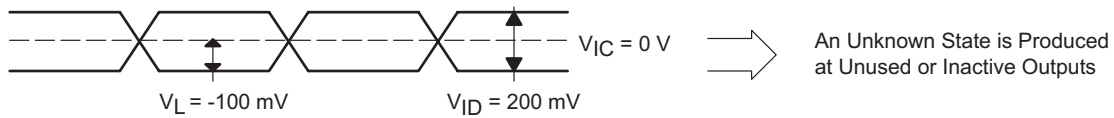

Figure 10. Waveform 2

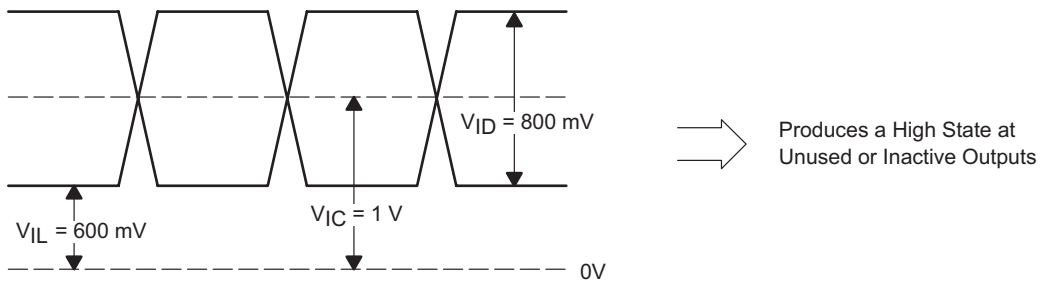

Figure 11. Waveform 3

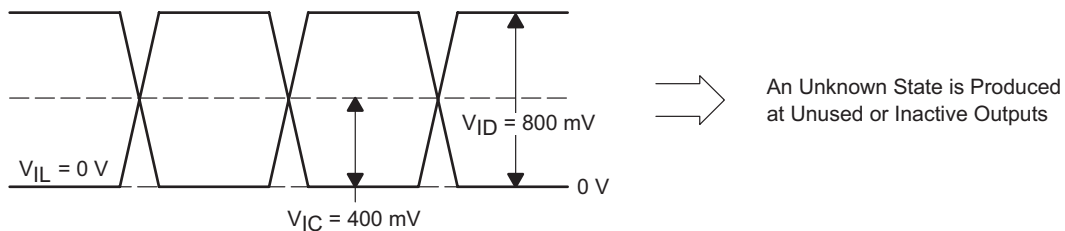
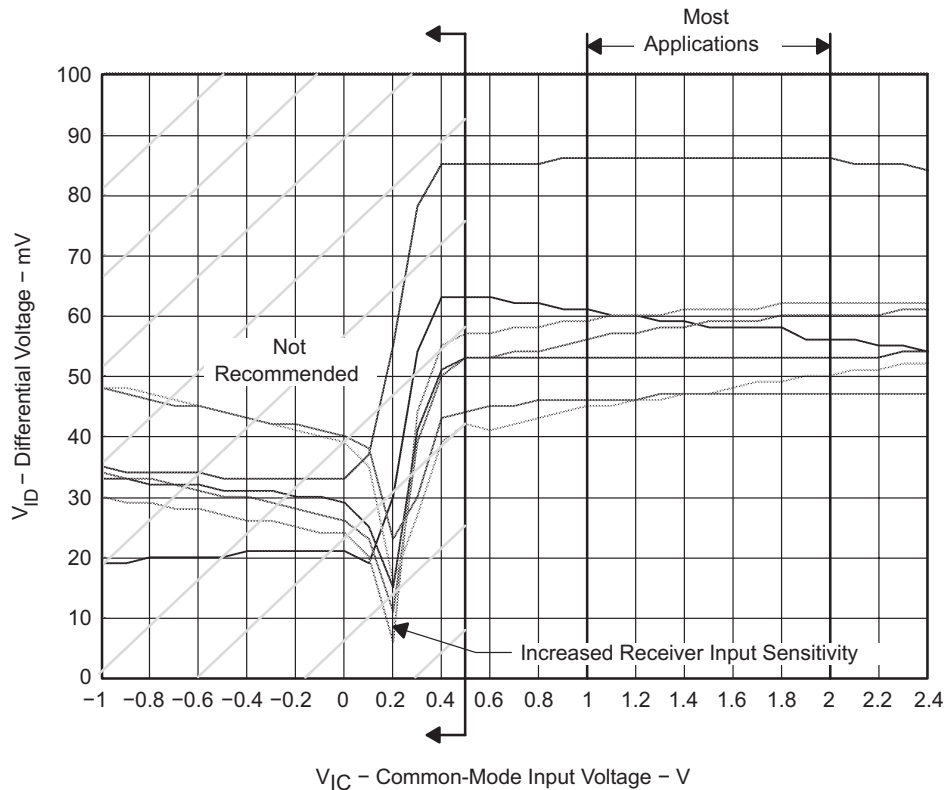

Figure 12. Waveform 4

In most applications, having a common-mode input close to ground and a differential voltage larger than 2 V is not customary. Because the common-mode input voltage is typically around 1.5 V, a 2-V  $V_{ID}$  would result in a  $V_{IL}$  of 0.5 V, thus satisfying the recommended  $V_{IL}$  level of greater than 0.4 V.

Figure 13 plots seven different input threshold curves from a variety of production lots and shows how the fail-safe circuitry behaves with the input common-mode voltage levels. These input threshold curves are representative samples of production devices. The curves specifically illustrate a typical range of input threshold variation. The AM26LV32 is specified with  $\pm 200$  mV of input sensitivity to account for the variance in input threshold. Each data point represents the input's ability to produce a known state at the output for a given  $V_{IC}$  and  $V_{ID}$ . Applying a differential voltage at or above a certain point on a curve would produce a known state at the

output. Applying a differential voltage less than a certain point on a curve would activate the fail-safe circuit and the output would be in a high state. For example, inspecting the top input threshold curve reveals that for a  $V_{IC}$  that is approximately 1.6 V,  $V_{ID}$  yields around 87 mV. Applying 90 mV of differential voltage to this particular production lot generates a known receiver output voltage. Applying a  $V_{ID}$  of 80 mV activates the input fail-safe circuitry and the receiver output is placed in the high state. Texas Instruments specifies the input threshold at  $\pm 200$  mV, because normal process variations affect this parameter. Note that at common-mode input voltages around 0.2 V, the input differential voltages are low compared to their respective data points. This phenomenon points to the fact that the inputs are very sensitive to small differential voltages around 0.2 V  $V_{IC}$ . TI recommends that  $V_{IC}$  levels be kept greater than 0.5 V to avoid this increased sensitivity at  $V_{IC} \approx 0.2$  V. In most applications, because  $V_{IC}$  typically is 1.5 V, the fail-safe circuitry functions properly to provide a high state at the receiver output.



**Figure 13.  $V_{IC}$  vs  $V_{ID}$  Receiver Sensitivity Levels**

Figure 14 represents a typical application where two receivers are not used. In this case, there is no need to worry about the output voltages of the unused receivers because these are not connected in the system architecture.

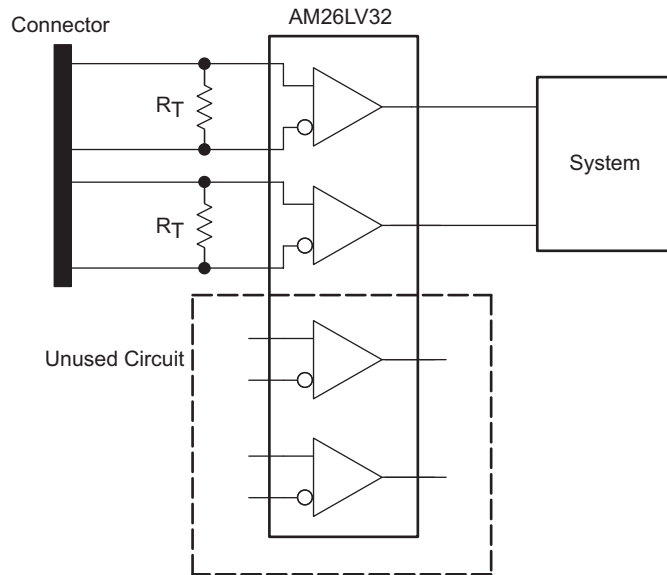

Copyright © 2016, Texas Instruments Incorporated

Figure 14. Typical Application With Unused Receivers

Figure 15 shows a common application where one or more drivers are either disabled or powered down. To ensure the inactive receiver outputs are in a high state, the active receiver inputs must have  $V_{IL} > 0.4\text{ V}$  and  $V_{IC} > 0.5\text{ V}$ .

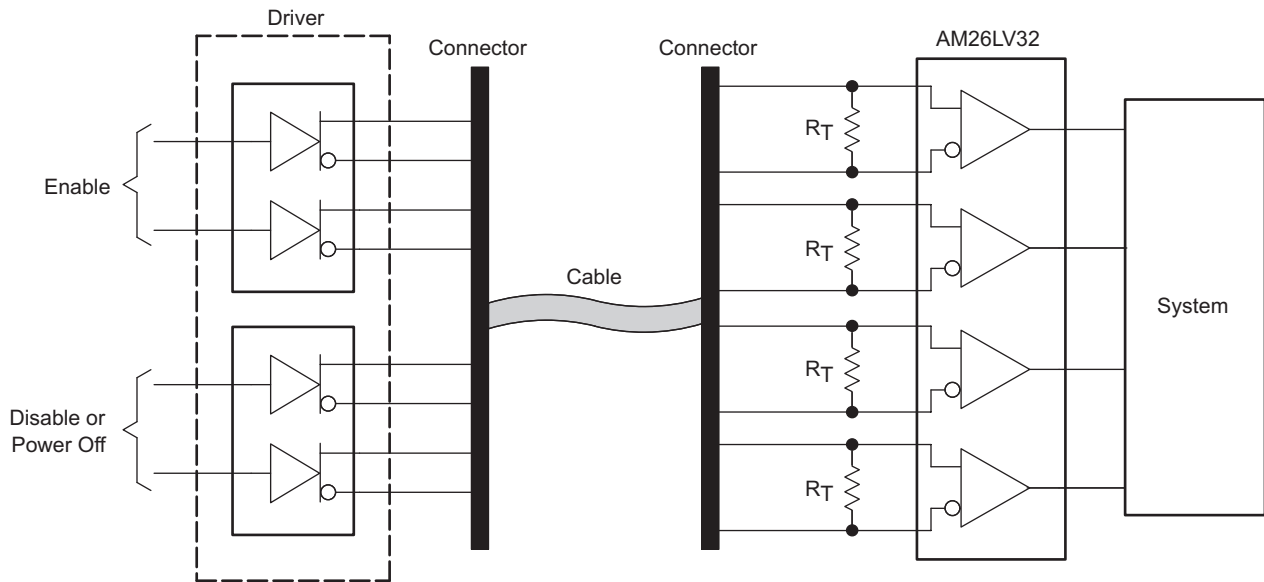

Copyright © 2016, Texas Instruments Incorporated

Figure 15. Typical Application Where Two or More Drivers Are Disabled

Figure 16 is an alternative application design to replace the application in Figure 15. This design uses two AM26LV32 devices instead of one. However, this design does not require the input levels be monitored to ensure the outputs are in the correct state, only that they comply to the RS-232 standard.

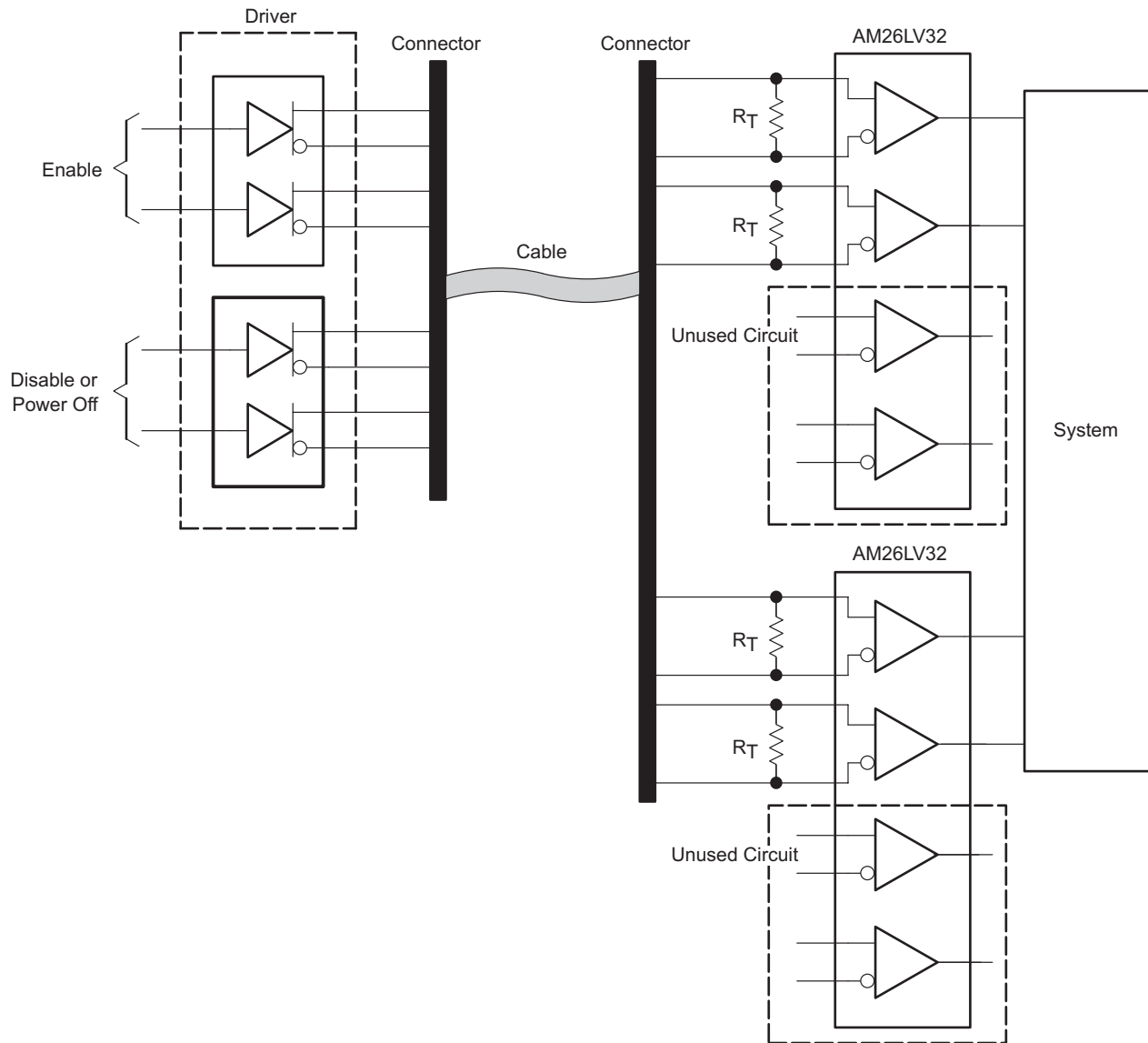

Copyright © 2016, Texas Instruments Incorporated

**Figure 16. Alternative Solution for [Figure 15](#)**

[Figure 17](#) and [Figure 18](#) show typical applications where a disconnected cable occurs. [Figure 17](#) illustrates a typical application where a cable is disconnected. Similar to [Figure 15](#), the active input levels must be monitored to make sure the inactive receiver outputs are in a high state. An alternative solution is shown in [Figure 18](#).

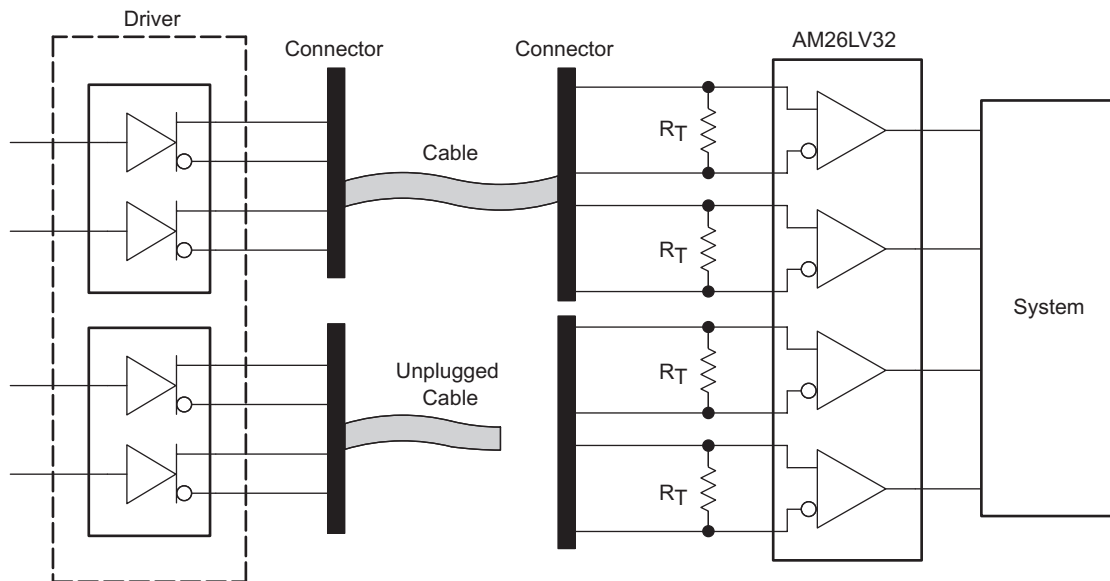

Copyright © 2016, Texas Instruments Incorporated

**Figure 17. Typical Application Where Two or More Drivers Are Disconnected**

Figure 18 is an alternative solution so the receiver inputs do not have to be monitored. This solution also requires the use of two AM26LV32 devices instead of one.

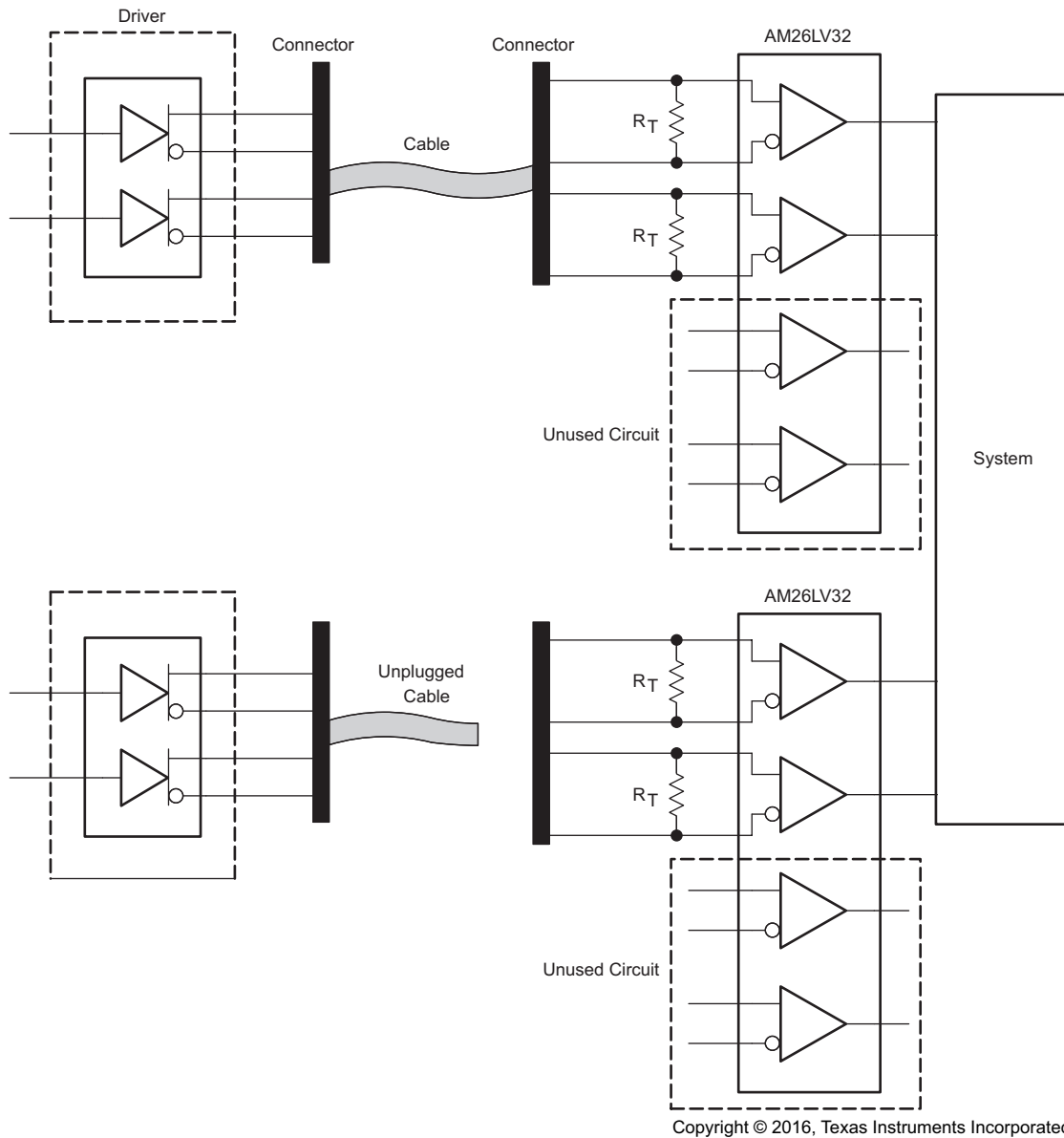

**Figure 18. Alternative Solution to [Figure 17](#)**

When designing a system using the AM26LV32, the device provides a robust solution where fail-safe and fault conditions are of concern. The RS422-like inputs accept common-mode input levels from  $-0.3\text{ V}$  to  $5.5\text{ V}$  with a specified sensitivity of  $\pm 200\text{ mV}$ . As previously shown, take care with active input levels because this can affect the outputs of unused or inactive bits. However, most applications meet or exceed the requirements to allow the device to perform properly.

## 9 Application and Implementation

### NOTE

Information in the following applications sections is not part of the TI component specification, and TI does not warrant its accuracy or completeness. TI's customers are responsible for determining suitability of components for their purposes. Customers should validate and test their design implementation to confirm system functionality.

### 9.1 Application Information

When designing a system that uses drivers, receivers, and transceivers that comply with RS422 or RS485, proper cable termination is essential for highly reliable applications with reduced reflections in the transmission line. Because RS422 allows only one driver on the bus, if termination is used, it is placed only at the end of the cable near the last receiver. In general, RS485 requires termination at both ends of the cable. Factors to consider when determining the type of termination usually are performance requirements of the application and the ever-present factor, cost. The different types of termination techniques include unterminated lines, parallel termination, ac termination, and multipoint termination.

### 9.2 Typical Application

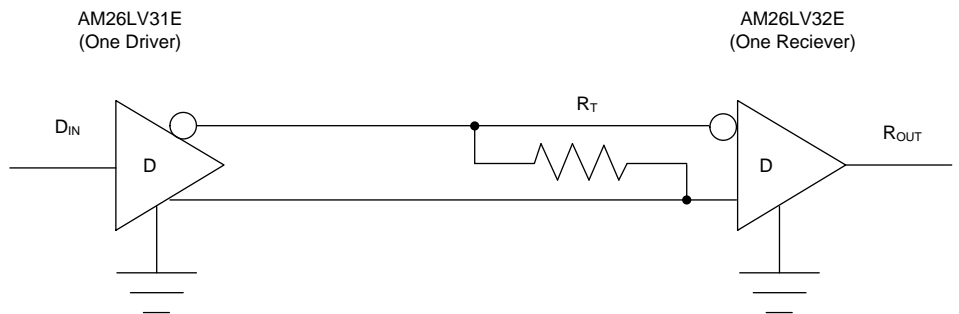

**Figure 19. Differential Terminated Configuration**

#### 9.2.1 Design Requirements

Resistor and capacitor (if used) termination values vary from system to system. The termination resistor,  $R_T$ , must be within 20% of the characteristic impedance,  $R_{OUT}$ , of the cable and can vary from about 80  $\Omega$  to 120  $\Omega$ .

#### 9.2.2 Detailed Design Procedure

Figure 19 shows a configuration with  $R_T$  as termination. Although reflections are present at the receiver inputs at a data signaling rate of 200 kbps with no termination, the RS422-compliant receiver reads only the input differential voltage and produces a clean signal at the output.

**Typical Application (continued)**

**9.2.3 Application Curve**

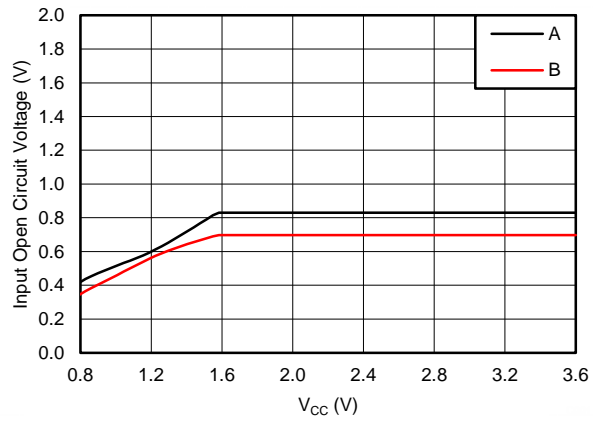

**Figure 20. RS422 Port Open-Circuit Voltage vs V<sub>CC</sub>**

## 10 Power Supply Recommendations

Place 0.1- $\mu\text{F}$  bypass capacitors close to the power-supply pins to reduce errors coupling in from noisy or high-impedance power supplies.

## 11 Layout

### 11.1 Layout Guidelines

For best operational performance of the device, use good PCB layout practices including:

- Noise can propagate into analog circuitry through the power pins of the circuit as a whole, as well as the operational amplifier. Bypass capacitors are used to reduce the coupled noise by providing low impedance power sources local to the analog circuitry.
- Connect low-ESR, 0.1- $\mu\text{F}$  ceramic bypass capacitors between each supply pin and ground, placed as close to the device as possible. A single bypass capacitor from V+ to ground is applicable for single-supply applications.
- Separate grounding for analog and digital portions of circuitry is one of the simplest and most-effective methods of noise suppression. One or more layers on multilayer PCBs are usually devoted to ground planes. A ground plane helps distribute heat and reduces EMI noise pickup. Make sure to physically separate digital and analog grounds, and pay attention to the flow of the ground current.
- To reduce parasitic coupling, run the input traces as far away from the supply or output traces as possible. If it is not possible to keep them separate, it is much better to cross the sensitive trace perpendicular as opposed to in parallel with the noisy trace.
- Place the external components as close to the device as possible. Keeping RF and RG close to the inverting input minimizes parasitic capacitance.
- Keep the length of input traces as short as possible. Always remember that the input traces are the most sensitive part of the circuit.
- Consider a driven, low-impedance guard ring around the critical traces. A guard ring can significantly reduce leakage currents from nearby traces that are at different potentials.

### 11.2 Layout Example

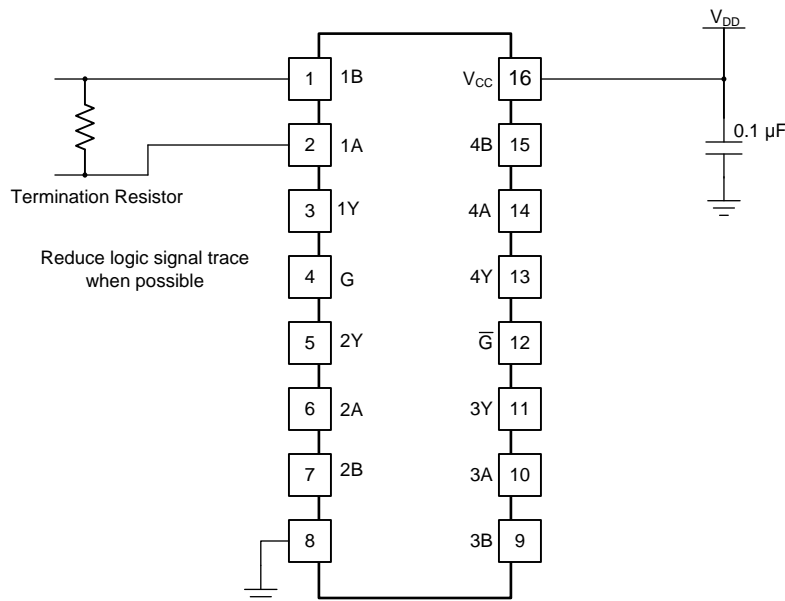

Figure 21. Layout With PCB Recommendations

## 12 Device and Documentation Support

### 12.1 Receiving Notification of Documentation Updates

To receive notification of documentation updates, navigate to the device product folder on ti.com. In the upper right corner, click on *Alert me* to register and receive a weekly digest of any product information that has changed. For change details, review the revision history included in any revised document.

### 12.2 Community Resources

The following links connect to TI community resources. Linked contents are provided "AS IS" by the respective contributors. They do not constitute TI specifications and do not necessarily reflect TI's views; see TI's [Terms of Use](#).

**TI E2E™ Online Community** *TI's Engineer-to-Engineer (E2E) Community*. Created to foster collaboration among engineers. At e2e.ti.com, you can ask questions, share knowledge, explore ideas and help solve problems with fellow engineers.

**Design Support** *TI's Design Support* Quickly find helpful E2E forums along with design support tools and contact information for technical support.

### 12.3 Trademarks

E2E is a trademark of Texas Instruments.  
All other trademarks are the property of their respective owners.

### 12.4 Electrostatic Discharge Caution



These devices have limited built-in ESD protection. The leads should be shorted together or the device placed in conductive foam during storage or handling to prevent electrostatic damage to the MOS gates.

### 12.5 Glossary

[SLYZ022](#) — *TI Glossary*.

This glossary lists and explains terms, acronyms, and definitions.

## 13 Mechanical, Packaging, and Orderable Information

The following pages include mechanical, packaging, and orderable information. This information is the most current data available for the designated devices. This data is subject to change without notice and revision of this document. For browser-based versions of this data sheet, refer to the left-hand navigation.

**PACKAGING INFORMATION**

Orderable Device	Status (1)	Package Type	Package Drawing	Pins	Package Qty	Eco Plan (2)	Lead/Ball Finish (6)	MSL Peak Temp (3)	Op Temp (°C)	Device Marking (4/5)	Samples
AM26LV32CD	ACTIVE	SOIC	D	16	40	Green (RoHS & no Sb/Br)	CU NIPDAU	Level-1-260C-UNLIM	0 to 70	AM26LV32C	<a href="#">Samples</a>
AM26LV32CDE4	ACTIVE	SOIC	D	16	40	Green (RoHS & no Sb/Br)	CU NIPDAU	Level-1-260C-UNLIM	0 to 70	AM26LV32C	<a href="#">Samples</a>
AM26LV32CDG4	ACTIVE	SOIC	D	16	40	Green (RoHS & no Sb/Br)	CU NIPDAU	Level-1-260C-UNLIM	0 to 70	AM26LV32C	<a href="#">Samples</a>
AM26LV32CDR	ACTIVE	SOIC	D	16	2500	Green (RoHS & no Sb/Br)	CU NIPDAU	Level-1-260C-UNLIM	0 to 70	AM26LV32C	<a href="#">Samples</a>
AM26LV32CDRE4	ACTIVE	SOIC	D	16	2500	Green (RoHS & no Sb/Br)	CU NIPDAU	Level-1-260C-UNLIM	0 to 70	AM26LV32C	<a href="#">Samples</a>
AM26LV32CDRG4	ACTIVE	SOIC	D	16	2500	Green (RoHS & no Sb/Br)	CU NIPDAU	Level-1-260C-UNLIM	0 to 70	AM26LV32C	<a href="#">Samples</a>
AM26LV32CNSR	ACTIVE	SO	NS	16	2000	Green (RoHS & no Sb/Br)	CU NIPDAU	Level-1-260C-UNLIM	0 to 70	26LV32	<a href="#">Samples</a>
AM26LV32CNSRG4	ACTIVE	SO	NS	16	2000	Green (RoHS & no Sb/Br)	CU NIPDAU	Level-1-260C-UNLIM	0 to 70	26LV32	<a href="#">Samples</a>
AM26LV32ID	ACTIVE	SOIC	D	16	40	Green (RoHS & no Sb/Br)	CU NIPDAU	Level-1-260C-UNLIM	-40 to 85	AM26LV32I	<a href="#">Samples</a>
AM26LV32IDE4	ACTIVE	SOIC	D	16	40	Green (RoHS & no Sb/Br)	CU NIPDAU	Level-1-260C-UNLIM	-40 to 85	AM26LV32I	<a href="#">Samples</a>
AM26LV32IDG4	ACTIVE	SOIC	D	16	40	Green (RoHS & no Sb/Br)	CU NIPDAU	Level-1-260C-UNLIM	-40 to 85	AM26LV32I	<a href="#">Samples</a>
AM26LV32IDR	ACTIVE	SOIC	D	16	2500	Green (RoHS & no Sb/Br)	CU NIPDAU	Level-1-260C-UNLIM	-40 to 85	AM26LV32I	<a href="#">Samples</a>
AM26LV32INS	ACTIVE	SO	NS	16	50	Green (RoHS & no Sb/Br)	CU NIPDAU	Level-1-260C-UNLIM	-40 to 85	26LV32I	<a href="#">Samples</a>
AM26LV32INSG4	ACTIVE	SO	NS	16	50	Green (RoHS & no Sb/Br)	CU NIPDAU	Level-1-260C-UNLIM	-40 to 85	26LV32I	<a href="#">Samples</a>
AM26LV32INSR	ACTIVE	SO	NS	16	2000	Green (RoHS & no Sb/Br)	CU NIPDAU	Level-1-260C-UNLIM	-40 to 85	26LV32I	<a href="#">Samples</a>

(1) The marketing status values are defined as follows:

**ACTIVE:** Product device recommended for new designs.

**LIFEBUY:** TI has announced that the device will be discontinued, and a lifetime-buy period is in effect.

**NRND:** Not recommended for new designs. Device is in production to support existing customers, but TI does not recommend using this part in a new design.

---

**PREVIEW:** Device has been announced but is not in production. Samples may or may not be available.

**OBSELETE:** TI has discontinued the production of the device.

<sup>(2)</sup> **RoHS:** TI defines "RoHS" to mean semiconductor products that are compliant with the current EU RoHS requirements for all 10 RoHS substances, including the requirement that RoHS substance do not exceed 0.1% by weight in homogeneous materials. Where designed to be soldered at high temperatures, "RoHS" products are suitable for use in specified lead-free processes. TI may reference these types of products as "Pb-Free".

**RoHS Exempt:** TI defines "RoHS Exempt" to mean products that contain lead but are compliant with EU RoHS pursuant to a specific EU RoHS exemption.

**Green:** TI defines "Green" to mean the content of Chlorine (Cl) and Bromine (Br) based flame retardants meet JS709B low halogen requirements of  $\leq 1000$ ppm threshold. Antimony trioxide based flame retardants must also meet the  $\leq 1000$ ppm threshold requirement.

<sup>(3)</sup> MSL, Peak Temp. - The Moisture Sensitivity Level rating according to the JEDEC industry standard classifications, and peak solder temperature.

<sup>(4)</sup> There may be additional marking, which relates to the logo, the lot trace code information, or the environmental category on the device.

<sup>(5)</sup> Multiple Device Markings will be inside parentheses. Only one Device Marking contained in parentheses and separated by a "~" will appear on a device. If a line is indented then it is a continuation of the previous line and the two combined represent the entire Device Marking for that device.

<sup>(6)</sup> Lead/Ball Finish - Orderable Devices may have multiple material finish options. Finish options are separated by a vertical ruled line. Lead/Ball Finish values may wrap to two lines if the finish value exceeds the maximum column width.

**Important Information and Disclaimer:** The information provided on this page represents TI's knowledge and belief as of the date that it is provided. TI bases its knowledge and belief on information provided by third parties, and makes no representation or warranty as to the accuracy of such information. Efforts are underway to better integrate information from third parties. TI has taken and continues to take reasonable steps to provide representative and accurate information but may not have conducted destructive testing or chemical analysis on incoming materials and chemicals. TI and TI suppliers consider certain information to be proprietary, and thus CAS numbers and other limited information may not be available for release.

In no event shall TI's liability arising out of such information exceed the total purchase price of the TI part(s) at issue in this document sold by TI to Customer on an annual basis.

**TAPE AND REEL INFORMATION**

**QUADRANT ASSIGNMENTS FOR PIN 1 ORIENTATION IN TAPE**

\*All dimensions are nominal

Device	Package Type	Package Drawing	Pins	SPQ	Reel Diameter (mm)	Reel Width W1 (mm)	A0 (mm)	B0 (mm)	K0 (mm)	P1 (mm)	W (mm)	Pin1 Quadrant
AM26LV32CDR	SOIC	D	16	2500	330.0	16.4	6.5	10.3	2.1	8.0	16.0	Q1
AM26LV32CDR	SOIC	D	16	2500	330.0	16.4	6.5	10.3	2.1	8.0	16.0	Q1
AM26LV32CDRG4	SOIC	D	16	2500	330.0	16.4	6.5	10.3	2.1	8.0	16.0	Q1
AM26LV32IDR	SOIC	D	16	2500	330.0	16.4	6.5	10.3	2.1	8.0	16.0	Q1

**TAPE AND REEL BOX DIMENSIONS**

\*All dimensions are nominal

Device	Package Type	Package Drawing	Pins	SPQ	Length (mm)	Width (mm)	Height (mm)
AM26LV32CDR	SOIC	D	16	2500	333.2	345.9	28.6
AM26LV32CDR	SOIC	D	16	2500	367.0	367.0	38.0
AM26LV32CDRG4	SOIC	D	16	2500	333.2	345.9	28.6
AM26LV32IDR	SOIC	D	16	2500	333.2	345.9	28.6

D (R-PDSO-G16)

PLASTIC SMALL OUTLINE

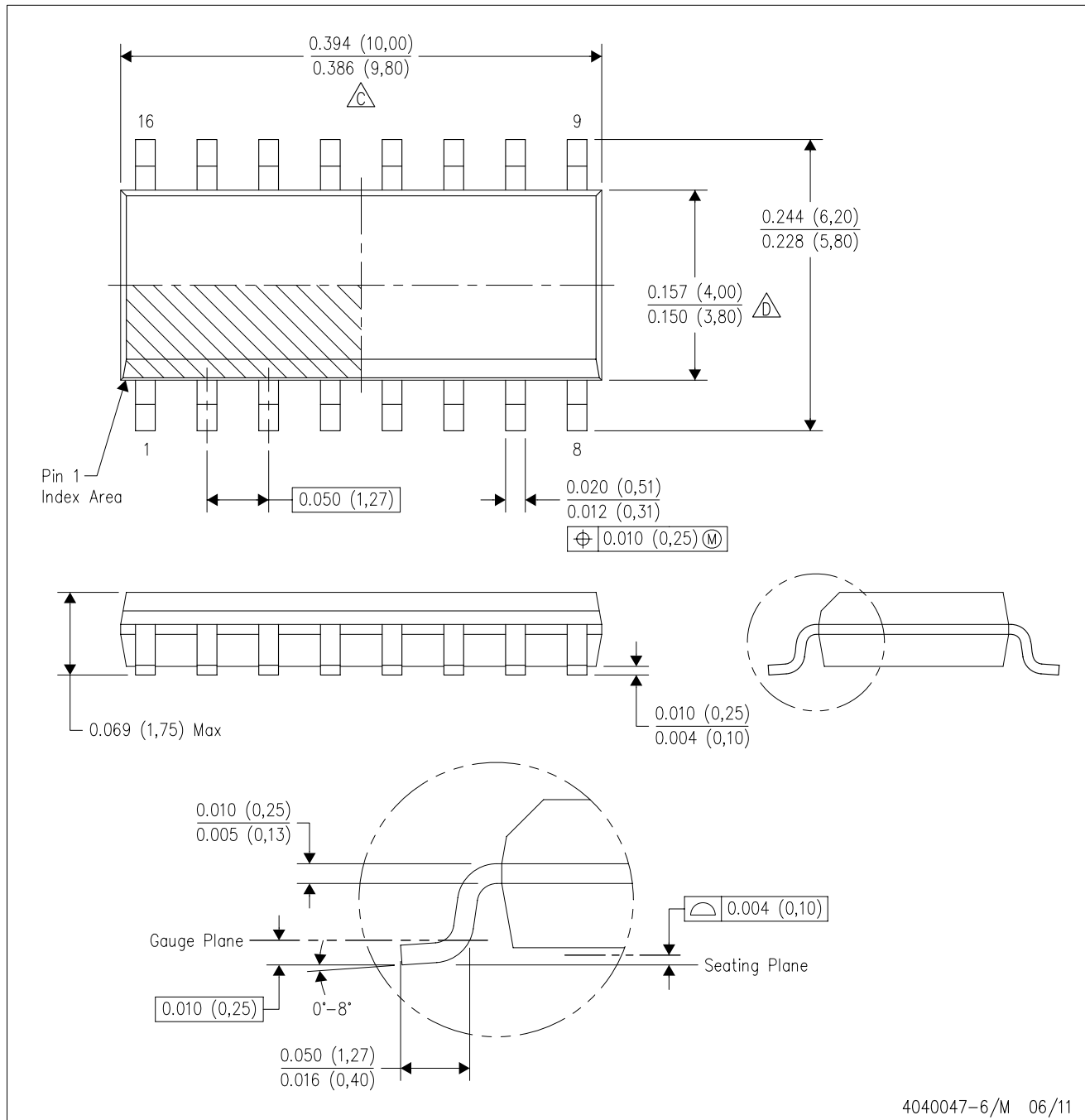

- NOTES:
- A. All linear dimensions are in inches (millimeters).
  - B. This drawing is subject to change without notice.
  - C. Body length does not include mold flash, protrusions, or gate burrs. Mold flash, protrusions, or gate burrs shall not exceed 0.006 (0,15) each side.
  - D. Body width does not include interlead flash. Interlead flash shall not exceed 0.017 (0,43) each side.
  - E. Reference JEDEC MS-012 variation AC.

D (R-PDSO-G16)

PLASTIC SMALL OUTLINE

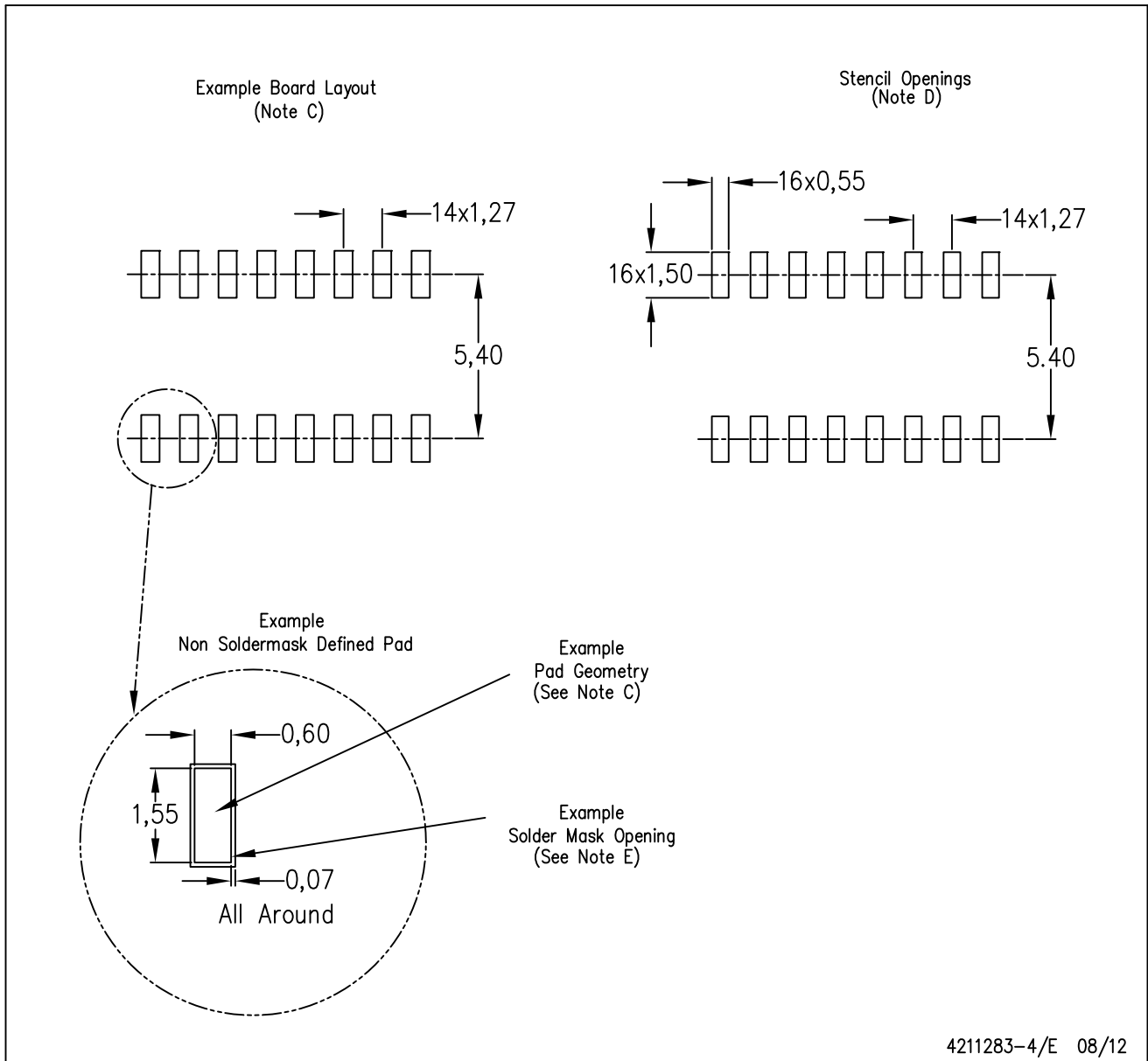

- NOTES:
- All linear dimensions are in millimeters.
  - This drawing is subject to change without notice.
  - Publication IPC-7351 is recommended for alternate designs.
  - Laser cutting apertures with trapezoidal walls and also rounding corners will offer better paste release. Customers should contact their board assembly site for stencil design recommendations. Refer to IPC-7525 for other stencil recommendations.
  - Customers should contact their board fabrication site for solder mask tolerances between and around signal pads.

# MECHANICAL DATA

NS (R-PDSO-G\*\*)

PLASTIC SMALL-OUTLINE PACKAGE

14-PINS SHOWN



- NOTES:
- A. All linear dimensions are in millimeters.
  - B. This drawing is subject to change without notice.
  - C. Body dimensions do not include mold flash or protrusion, not to exceed 0,15.

## IMPORTANT NOTICE

Texas Instruments Incorporated (TI) reserves the right to make corrections, enhancements, improvements and other changes to its semiconductor products and services per JESD46, latest issue, and to discontinue any product or service per JESD48, latest issue. Buyers should obtain the latest relevant information before placing orders and should verify that such information is current and complete.

TI's published terms of sale for semiconductor products (<http://www.ti.com/sc/docs/stdterms.htm>) apply to the sale of packaged integrated circuit products that TI has qualified and released to market. Additional terms may apply to the use or sale of other types of TI products and services.

Reproduction of significant portions of TI information in TI data sheets is permissible only if reproduction is without alteration and is accompanied by all associated warranties, conditions, limitations, and notices. TI is not responsible or liable for such reproduced documentation. Information of third parties may be subject to additional restrictions. Resale of TI products or services with statements different from or beyond the parameters stated by TI for that product or service voids all express and any implied warranties for the associated TI product or service and is an unfair and deceptive business practice. TI is not responsible or liable for any such statements.

Buyers and others who are developing systems that incorporate TI products (collectively, "Designers") understand and agree that Designers remain responsible for using their independent analysis, evaluation and judgment in designing their applications and that Designers have full and exclusive responsibility to assure the safety of Designers' applications and compliance of their applications (and of all TI products used in or for Designers' applications) with all applicable regulations, laws and other applicable requirements. Designer represents that, with respect to their applications, Designer has all the necessary expertise to create and implement safeguards that (1) anticipate dangerous consequences of failures, (2) monitor failures and their consequences, and (3) lessen the likelihood of failures that might cause harm and take appropriate actions. Designer agrees that prior to using or distributing any applications that include TI products, Designer will thoroughly test such applications and the functionality of such TI products as used in such applications.

TI's provision of technical, application or other design advice, quality characterization, reliability data or other services or information, including, but not limited to, reference designs and materials relating to evaluation modules, (collectively, "TI Resources") are intended to assist designers who are developing applications that incorporate TI products; by downloading, accessing or using TI Resources in any way, Designer (individually or, if Designer is acting on behalf of a company, Designer's company) agrees to use any particular TI Resource solely for this purpose and subject to the terms of this Notice.

TI's provision of TI Resources does not expand or otherwise alter TI's applicable published warranties or warranty disclaimers for TI products, and no additional obligations or liabilities arise from TI providing such TI Resources. TI reserves the right to make corrections, enhancements, improvements and other changes to its TI Resources. TI has not conducted any testing other than that specifically described in the published documentation for a particular TI Resource.

Designer is authorized to use, copy and modify any individual TI Resource only in connection with the development of applications that include the TI product(s) identified in such TI Resource. NO OTHER LICENSE, EXPRESS OR IMPLIED, BY ESTOPPEL OR OTHERWISE TO ANY OTHER TI INTELLECTUAL PROPERTY RIGHT, AND NO LICENSE TO ANY TECHNOLOGY OR INTELLECTUAL PROPERTY RIGHT OF TI OR ANY THIRD PARTY IS GRANTED HEREIN, including but not limited to any patent right, copyright, mask work right, or other intellectual property right relating to any combination, machine, or process in which TI products or services are used. Information regarding or referencing third-party products or services does not constitute a license to use such products or services, or a warranty or endorsement thereof. Use of TI Resources may require a license from a third party under the patents or other intellectual property of the third party, or a license from TI under the patents or other intellectual property of TI.

TI RESOURCES ARE PROVIDED "AS IS" AND WITH ALL FAULTS. TI DISCLAIMS ALL OTHER WARRANTIES OR REPRESENTATIONS, EXPRESS OR IMPLIED, REGARDING RESOURCES OR USE THEREOF, INCLUDING BUT NOT LIMITED TO ACCURACY OR COMPLETENESS, TITLE, ANY EPIDEMIC FAILURE WARRANTY AND ANY IMPLIED WARRANTIES OF MERCHANTABILITY, FITNESS FOR A PARTICULAR PURPOSE, AND NON-INFRINGEMENT OF ANY THIRD PARTY INTELLECTUAL PROPERTY RIGHTS. TI SHALL NOT BE LIABLE FOR AND SHALL NOT DEFEND OR INDEMNIFY DESIGNER AGAINST ANY CLAIM, INCLUDING BUT NOT LIMITED TO ANY INFRINGEMENT CLAIM THAT RELATES TO OR IS BASED ON ANY COMBINATION OF PRODUCTS EVEN IF DESCRIBED IN TI RESOURCES OR OTHERWISE. IN NO EVENT SHALL TI BE LIABLE FOR ANY ACTUAL, DIRECT, SPECIAL, COLLATERAL, INDIRECT, PUNITIVE, INCIDENTAL, CONSEQUENTIAL OR EXEMPLARY DAMAGES IN CONNECTION WITH OR ARISING OUT OF TI RESOURCES OR USE THEREOF, AND REGARDLESS OF WHETHER TI HAS BEEN ADVISED OF THE POSSIBILITY OF SUCH DAMAGES.

Unless TI has explicitly designated an individual product as meeting the requirements of a particular industry standard (e.g., ISO/TS 16949 and ISO 26262), TI is not responsible for any failure to meet such industry standard requirements.

Where TI specifically promotes products as facilitating functional safety or as compliant with industry functional safety standards, such products are intended to help enable customers to design and create their own applications that meet applicable functional safety standards and requirements. Using products in an application does not by itself establish any safety features in the application. Designers must ensure compliance with safety-related requirements and standards applicable to their applications. Designer may not use any TI products in life-critical medical equipment unless authorized officers of the parties have executed a special contract specifically governing such use. Life-critical medical equipment is medical equipment where failure of such equipment would cause serious bodily injury or death (e.g., life support, pacemakers, defibrillators, heart pumps, neurostimulators, and implantables). Such equipment includes, without limitation, all medical devices identified by the U.S. Food and Drug Administration as Class III devices and equivalent classifications outside the U.S.

TI may expressly designate certain products as completing a particular qualification (e.g., Q100, Military Grade, or Enhanced Product). Designers agree that it has the necessary expertise to select the product with the appropriate qualification designation for their applications and that proper product selection is at Designers' own risk. Designers are solely responsible for compliance with all legal and regulatory requirements in connection with such selection.

Designer will fully indemnify TI and its representatives against any damages, costs, losses, and/or liabilities arising out of Designer's non-compliance with the terms and provisions of this Notice.

## Looking for pricing, stock, or lifecycle information?

Click below to explore more details on WIN SOURCE:

 [View AM26LV32CDR](#) on WIN SOURCE

 [Texas Instruments](#) Information

## Optimize Your Supply Chain with WIN SOURCE Solutions

-  Global Sourcing Solution
-  Obsolete Management
-  Cost Control Management
-  Shortage Management
-  Alternative Solution
-  Excess Inventory Management