



**THE DATASHEET OF
AM26LV31CD**



AM26LV31 Low-Voltage High-Speed Quadruple Differential Line Drivers

1 Features

- Switching Rates up to 32 MHz
- Operate From a Single 3.3-V Supply
- Propagation Delay Time: 8 ns Typical
- Pulse Skew Time: 500 ps Typical
- High Output-Drive Current: ± 30 mA
- Controlled Rise and Fall Times: 3 ns Typical
- Differential Output Voltage With 100- Ω Load: 1.5 V Typical
- Ultra-Low Power Dissipation
 - dc, 0.3 mW Maximum
 - 32 MHz All Channels (No Load), 385 mW Typical
- Accept 5-V Logic Inputs With 3.3-V Supply
- Low-Voltage Pin-to-Pin Compatible Replacement for AM26C31, AM26LS31, MB571
- High Output Impedance in Power-Off Condition
- Driver Output Short-Protection Circuit
- Package Options Include Plastic Small-Outline (D, NS) Packages

2 Applications

- Motor Control: Brushless DC and Brushed DC
- Field Transmitters: Temperature Sensors and Pressure Sensors
- Temperature Sensors or Controllers Using Modbus

3 Description

The AM26LV31C and AM26LV31I are BiCMOS quadruple differential line drivers with 3-state outputs. They are designed to be similar to TIA/EIA-422-B and ITU Recommendation V.11 drivers with reduced supply-voltage range.

The devices are optimized for balanced-bus transmission at switching rates up to 32 MHz. The outputs have very high current capability for driving balanced lines such as twisted-pair transmission lines and provide a high impedance in the power-off condition. The enable function is common to all four drivers and offers the choice of active-high or active-low enable inputs. The AM26LV31C and AM26LV31I are designed using Texas Instruments proprietary LinIMPACT-C60™ technology, facilitating ultra-low power consumption without sacrificing speed. These devices offer optimum performance when used with the AM26LV32 quadruple line receivers.

The AM26LV31C is characterized for operation from 0°C to 70°C. The AM26LV31I is characterized for operation from –45°C to 85°C.

Device Information⁽¹⁾

PART NUMBER	PACKAGE	BODY SIZE (NOM)
AM26LV31C	SOIC (D) 16	9.90 mm x 3.91 mm
AM26LV31I	SOIC (D) 16	9.90 mm x 3.91 mm
	SO (NS) 16	10.3 mm x 5.30 mm

(1) For all available packages, see the orderable addendum at the end of the data sheet.

Logic Diagram (Positive Logic)

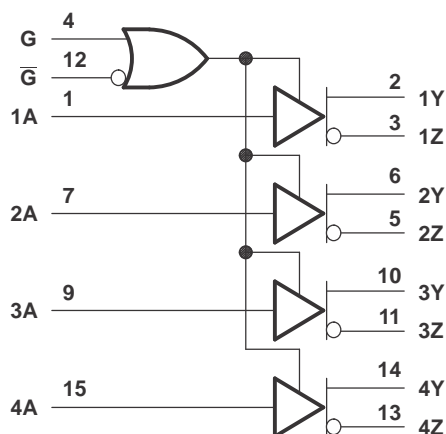

Table of Contents

1 Features	1	8.3 Feature Description	10
2 Applications	1	8.4 Device Functional Modes	11
3 Description	1	9 Application and Implementation	12
4 Revision History	2	9.1 Application Information	12
5 Pin Configuration and Functions	3	9.2 Typical Application	12
6 Specifications	4	10 Power Supply Recommendations	13
6.1 Absolute Maximum Ratings	4	11 Layout	14
6.2 ESD Ratings	4	11.1 Layout Guidelines	14
6.3 Recommended Operating Conditions	4	11.2 Layout Example	14
6.4 Thermal Information	4	12 Device and Documentation Support	15
6.5 Electrical Characteristics	5	12.1 Device Support	15
6.6 Switching Characteristics	5	12.2 Receiving Notification of Documentation Updates	15
6.7 Typical Characteristics	6	12.3 Community Resources	15
7 Parameter Measurement Information	7	12.4 Trademarks	15
8 Detailed Description	10	12.5 Electrostatic Discharge Caution	15
8.1 Overview	10	12.6 Glossary	15
8.2 Functional Block Diagram	10	13 Mechanical, Packaging, and Orderable Information	15

4 Revision History

NOTE: Page numbers for previous revisions may differ from page numbers in the current version.

Changes from Revision G (May 2005) to Revision H	Page
• Added <i>Device Information</i> table, <i>ESD Ratings</i> table, <i>Feature Description</i> section, <i>Device Functional Modes</i> , <i>Application and Implementation</i> section, <i>Power Supply Recommendations</i> section, <i>Layout</i> section, <i>Device and Documentation Support</i> section, and <i>Mechanical, Packaging, and Orderable Information</i> section	1
• Changed the t_{PLH} and t_{PHL} MAX value From: 12 ns To: 20 ns in the <i>Switching Characteristics</i>	5
• Changed the $t_{sk(p)}$ and $t_{sk(o)}$ MAX value From: 1.5 ns To: 3 ns in the <i>Switching Characteristics</i>	5

5 Pin Configuration and Functions

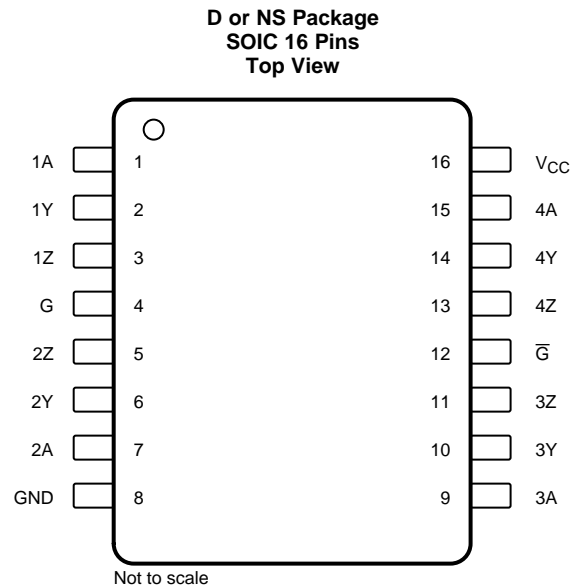

Pin Functions

PIN		I/O	DESCRIPTION
NO.	NAME		
1	1A	I	Driver 1 input
2	1Y	O	Driver 1 output
3	1Z	O	Driver 1 inverted output
4	G	I	Active high enable
5	2Z	O	Driver 2 inverted output
6	2Y	O	Driver 2 output
7	2A	I	Driver 2 input
8	GND	—	Ground pin
9	3A	I	Driver 3 input
10	3Y	O	Driver 3 output
11	3Z	O	Driver 3 inverted output
12	\bar{G}	I	Active low enable
13	4Z	O	Driver 4 inverted output
14	4Y	O	Driver 4 output
15	4A	I	Driver 4 input
16	V _{CC}	—	Power pin

6 Specifications

6.1 Absolute Maximum Ratings

over operating free-air temperature range (unless otherwise noted)⁽¹⁾

	MIN	MAX	UNIT
Supply voltage range, V_{CC} ⁽²⁾	-0.3	6	V
Input voltage range, V_I	-0.3	6	V
Output voltage range, V_O	-0.3	6	V
Storage temperature, T_{stg}	-65	150	°C

- (1) Stresses beyond those listed under *Absolute Maximum Ratings* may cause permanent damage to the device. These are stress ratings only, which do not imply functional operation of the device at these or any other conditions beyond those indicated under *Recommended Operating Conditions*. Exposure to absolute-maximum-rated conditions for extended periods may affect device reliability.
- (2) All voltage values are with respect to GND.

6.2 ESD Ratings

		VALUE	UNIT
$V_{(ESD)}$ Electrostatic discharge	Human-body model (HBM), per ANSI/ESDA/JEDEC JS-001 ⁽¹⁾	±3000	V
	Charged-device model (CDM), per JEDEC specification JESD22-C101 ⁽²⁾	±250	

- (1) JEDEC document JEP155 states that 500-V HBM allows safe manufacturing with a standard ESD control process. .
- (2) JEDEC document JEP157 states that 250-V CDM allows safe manufacturing with a standard ESD control process.

6.3 Recommended Operating Conditions

		MIN	NOM	MAX	UNIT
V_{CC}	Supply voltage	3	3.3	3.6	V
V_{IH}	High-level input voltage	2			V
V_{IL}	Low-level input voltage			0.8	V
I_{OH}	High-level output current			-30	mA
I_{OL}	Low-level output current			30	mA
T_A	Operating free-air temperature	AM26LV31C		70	°C
		AM26LV31I	-45	85	°C

6.4 Thermal Information

THERMAL METRIC ⁽¹⁾		D (SOIC)	NS (SO)	UNIT
		16 PINS	16 PINS	
$R_{\theta JA}$	Junction-to-ambient thermal resistance	81.9	76.9	°C/W
$R_{\theta JC(top)}$	Junction-to-case (top) thermal resistance	40.3	33.1	°C/W
$R_{\theta JB}$	Junction-to-board thermal resistance	40.1	37.1	°C/W
Ψ_{JT}	Junction-to-top characterization parameter	7.9	4.3	°C/W
Ψ_{JB}	Junction-to-board characterization parameter	39.8	37.3	°C/W
$R_{\theta JC(bot)}$	Junction-to-case (bottom) thermal resistance	n/a	n/a	°C/W

- (1) For more information about traditional and new thermal metrics, see the [Semiconductor and IC Package Thermal Metrics](#) application report.

6.5 Electrical Characteristics

over recommended operating supply-voltage and free-air temperature ranges (unless otherwise noted)

PARAMETER		TEST CONDITIONS	MIN	TYP ⁽¹⁾	MAX	UNIT
V _{IK}	Input clamp voltage	I _I = 18 mA			-1.5	V
V _{OH}	High-level output voltage	V _{IH} = 2 V, I _{OH} = -12 mA	1.85	2.3		V
V _{OL}	Low-level output voltage	V _{IL} = 0.8 V, I _{OH} = 12 mA		0.8	1.05	V
V _{OD}	Differential output voltage ⁽²⁾	R _L = 100 Ω	0.95	1.5		V
V _{OC}	Common-mode output voltage		1.3	1.55	1.8	V
Δ V _{OC}	Change in magnitude of common-mode output voltage ⁽²⁾				±0.2	V
I _O	Output current with power off	V _O = -0.25 V or 6 V, V _{CC} = 0			±100	μA
I _{OZ}	Off-state (high-impedance state) output current	V _O = -0.25 V or 6 V, G = 0.8 V or \overline{G} = 2 V			±100	μA
I _H	High-level input current	V _{CC} = 0 or 3 V, V _I = 5.5 V			10	μA
I _L	Low-level input current	V _{CC} = 3.6 V, V _I = 0			-10	μA
I _{OS}	Short-circuit output current	V _{CC} = 3.6 V, V _O = 0			-200	mA
I _{CC}	Supply current (all drivers)	V _I = V _{CC} or GND, No load			100	μA
C _{pd}	Power-dissipation capacitance (all drivers) ⁽³⁾	No load		160		pF

(1) All typical values are at V_{CC} = 3.3 V, T_A = 25°C.

(2) Δ|V_{OD}| and Δ|V_{OC}| are the changes in magnitude of V_{OD} and V_{OC}, respectively, that occur when the input is changed from a high level to a low level.

(3) C_{pd} determines the no-load dynamic current consumption. I_S = C_{pd} × V_{CC} × f + I_{CC}

6.6 Switching Characteristics

V_{CC} = 3.3 V, T_A = 25°C

PARAMETER		TEST CONDITIONS	MIN	TYP ⁽¹⁾	MAX	UNIT
t _{PLH}	Propagation delay time, low- to high-level output	See Figure 3	4	8	20	ns
t _{PHL}	Propagation delay time, high- to low-level output		4	8	20	ns
t _t	Transition time (t _r or t _f)			3		ns
SR	Slew rate, single-ended output voltage	See Note ⁽²⁾ and Figure 3		0.3	1	V/ns
t _{PZH}	Output-enable time to high level	See Figure 4		10	20	ns
t _{PZL}	Output-enable time to low level	See Figure 5		10	20	ns
t _{PHZ}	Output-disable time from high level	See Figure 4		10	20	ns
t _{PLZ}	Output-disable time from low level	See Figure 5		10	20	ns
t _{sk(p)}	Pulse skew	f = 32 MHz, See Note ⁽³⁾		0.5	3	ns
t _{sk(o)}	Skew limit	f = 32 MHz			3	ns
t _{sk(lim)}	Skew limit (device to device)	f = 32 MHz, See Note ⁽⁴⁾			3	ns

(1) All typical values are at V_{CC} = 3.3 V, T_A = 25°C.

(2) Slew rate is defined by [Equation 1](#)

(3) Pulse skew is defined as the |t_{PLH} - t_{PHL}| of each channel of the same device.

(4) Skew limit (device to device) is the maximum difference in propagation delay times between any two channels of any two devices.

$$SR = \frac{90\%(V_{OH} - V_{OL}) - 10\%(V_{OH} - V_{OL})}{t_r}, \text{ the differential slew rate of } V_{CC} \text{ is } 2 \times SR. \tag{1}$$

6.7 Typical Characteristics

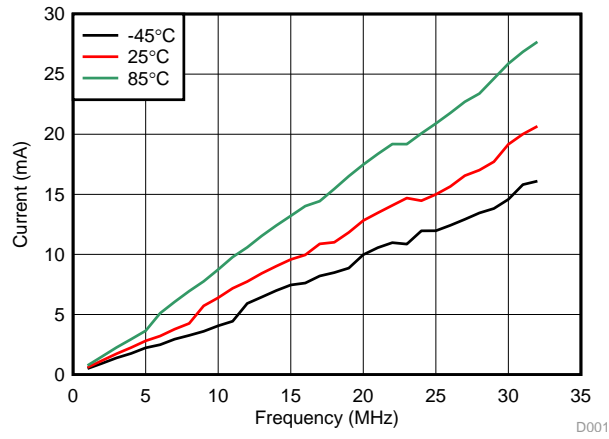

Figure 1. Current vs Frequency

7 Parameter Measurement Information

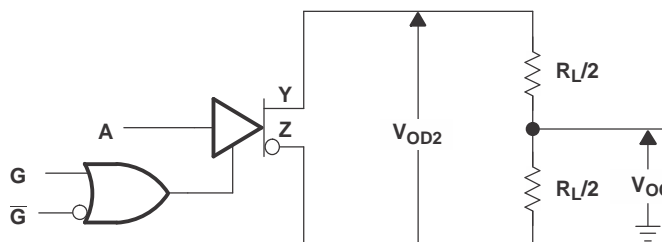
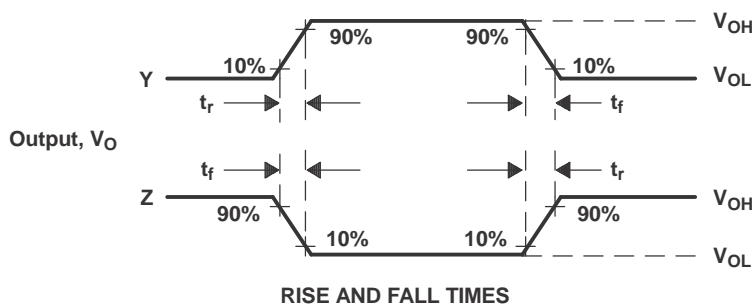
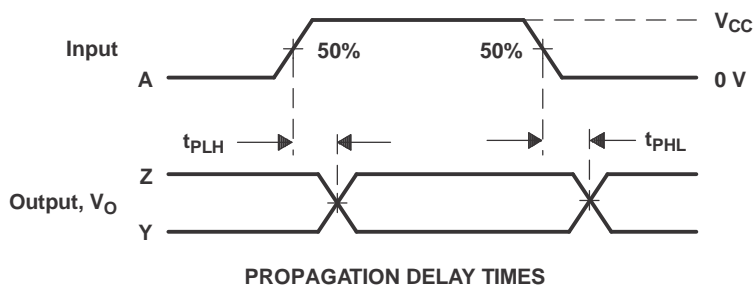
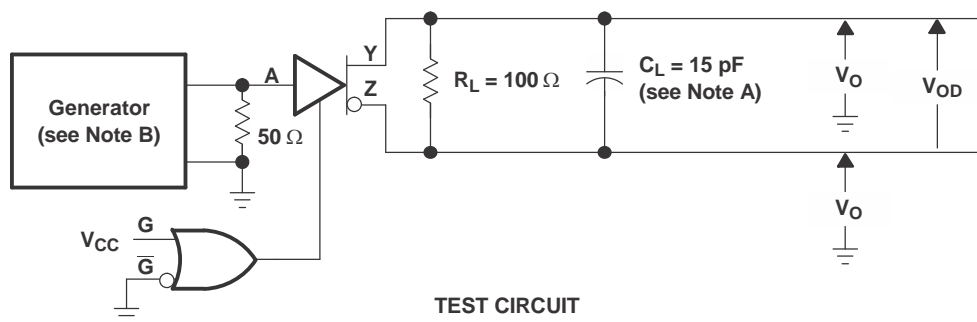

Figure 2. Differential and Common-Mode Output Voltages



- A. C_L includes probe and jig capacitance.
- B. The input pulse is supplied by a generator having the following characteristics: PRR = 32 MHz, $Z_0 = 50 \Omega$, 50%v duty cycle, t_r and $t_f \leq 2$ ns.

Figure 3. Test Circuit and Voltage Waveforms, t_{PHL} and t_{PLH}

Parameter Measurement Information (continued)

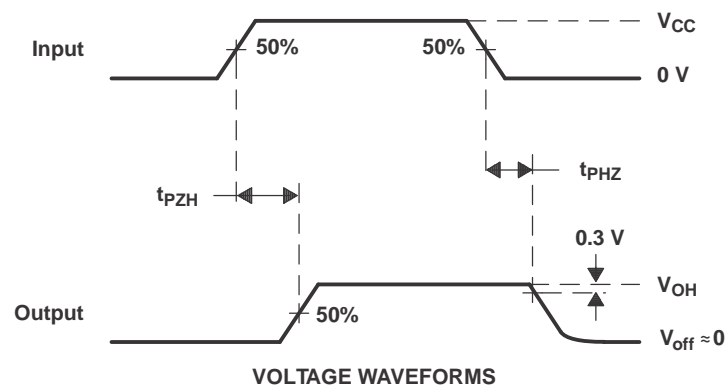
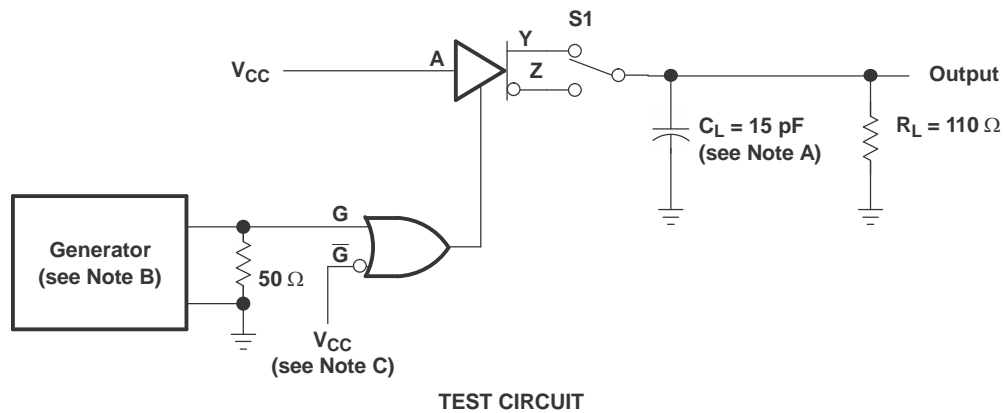

- A. C_L includes probe and jig capacitance.
- B. The input pulse is supplied by a generator having the following characteristics: PRR = 1 MHz, $Z_O = 50 \Omega$, 50%v duty cycle, t_r and t_f (10% to 90%) ≤ 2 ns.
- C. To test the active-low enable \overline{G} , ground G and apply an inverted waveform to \overline{G} .

Figure 4. Test Circuit and Voltage Waveforms, t_{PZH} and t_{PHZ}

Parameter Measurement Information (continued)

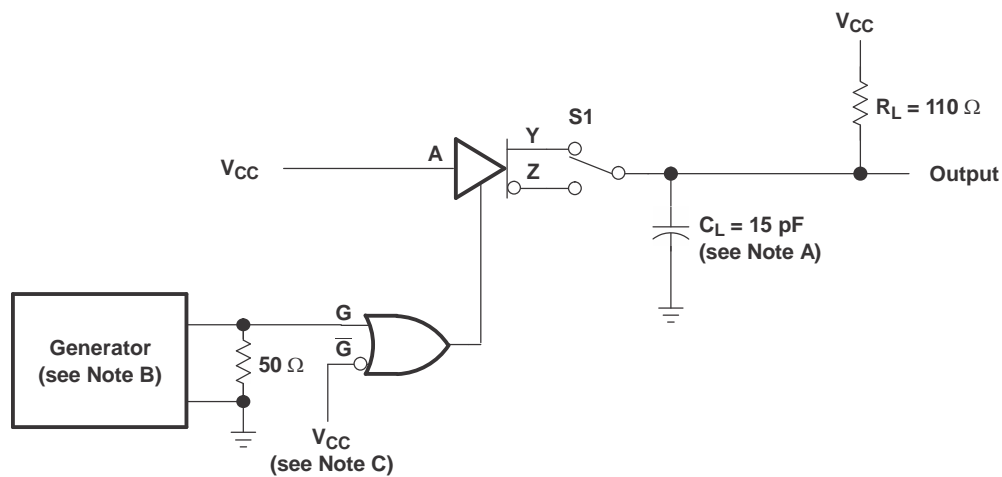

TEST CIRCUIT

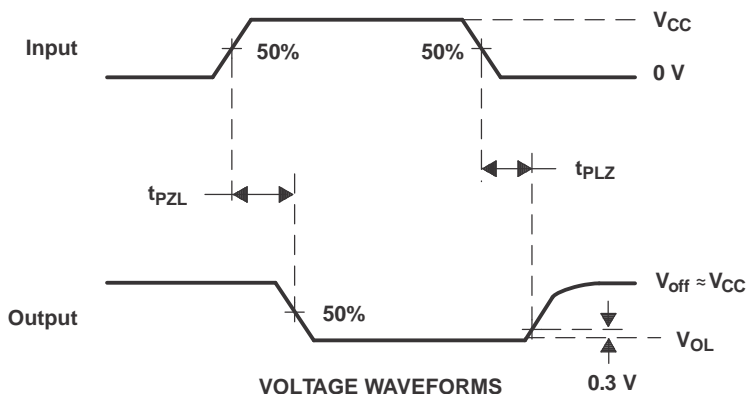

VOLTAGE WAVEFORMS

- A. C_L includes probe and jig capacitance.
- B. The input pulse is supplied by a generator having the following characteristics: PRR = 1 MHz, $Z_O = 50 \Omega$, 50%v duty cycle, t_r and t_f (10% to 90%) ≤ 2 ns.
- C. To test the active-low enable \overline{G} , ground G and apply an inverted waveform to \overline{G} .

Figure 5. Test Circuit and Voltage Waveforms, t_{PZL} and t_{PLZ}

8 Detailed Description

8.1 Overview

The AM26LV31C and AM26LV31I are BiCMOS quadruple differential line drivers with 3-state outputs. The devices are designed to be similar to TIA/EIA-422-B and ITU Recommendation V.11 drivers with a single 3.3-V power supply. The drivers also integrate active-high and active-low enables for precise device control.

8.2 Functional Block Diagram

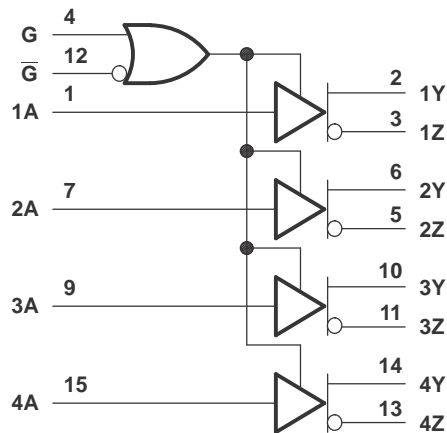

8.3 Feature Description

8.3.1 Active high and active low

The devices can be configured using the G and G logic inputs to select transmitter output. A logic high on the G pin or a logic low on the G pin enables the device to operate. These pins are simply a way to configure the logic to match that of the receiving or transmitting controller or microprocessor.

8.3.2 Operates from a 3.3-V Supply with up to 5-V Logic

While the transmitters operate from a single 3.3-V rail, the logic can operate off the same rail or another 5-V rail, making designs much more flexible to communicate to controllers.

8.3.3 High Speed Transmission

The AM26LV31C and AM26LV31I are optimized for balanced-bus transmission at switching rates up to 32 MHz. The devices are designed using Texas Instruments proprietary LinIMPACT-C60™ technology, facilitating ultra-low power consumption without sacrificing speed.

8.4 Device Functional Modes

Table 1. Function Table⁽¹⁾

INPUT A	ENABLES		OUTPUTS	
	G	\bar{G}	Y	Z
H	H	X	H	L
L	H	X	L	H
H	X	L	H	L
L	X	L	L	H
X	L	H	Z	Z

(1) H = high level, L = low level, X = irrelevant, Z = high impedance (off)

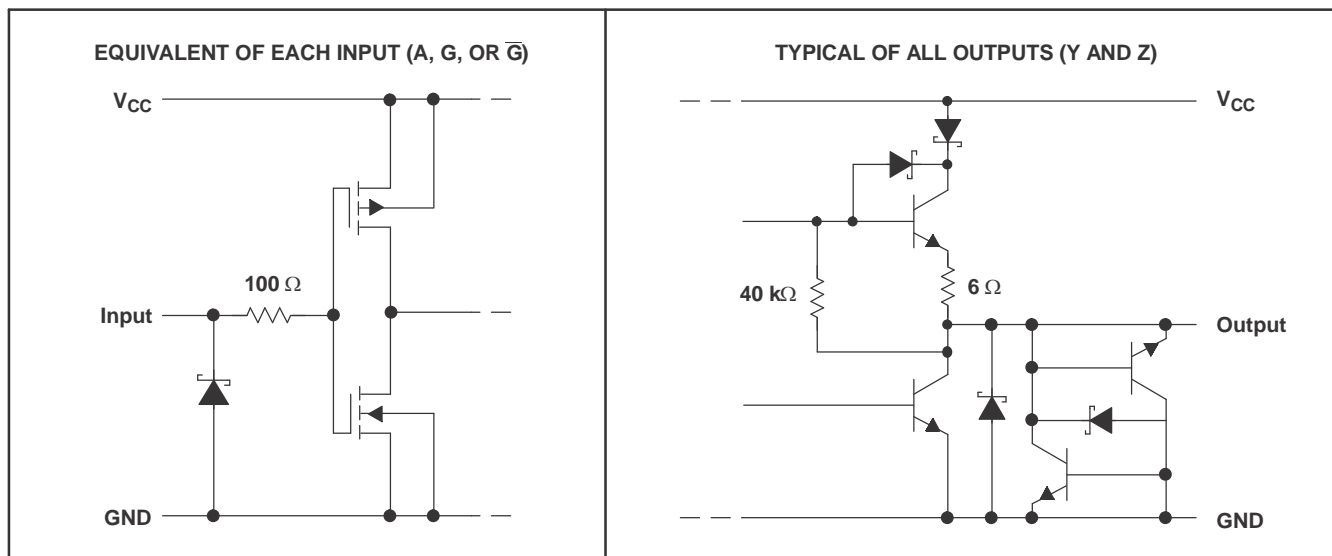

If resistor values are nominal.

Figure 6. Schematic (Each Driver)

9 Application and Implementation

NOTE

Information in the following applications sections is not part of the TI component specification, and TI does not warrant its accuracy or completeness. TI's customers are responsible for determining suitability of components for their purposes. Customers should validate and test their design implementation to confirm system functionality.

9.1 Application Information

When designing a system that uses drivers, receivers, and transceivers, proper cable termination is essential for highly reliable applications with reduced reflections in the transmission line. If termination is used, it can be placed at the end of the cable near the last receiver. Factors to consider when determining the type of termination usually are performance requirements of the application and the ever-present factor, cost. The different types of termination techniques discussed are unterminated lines, parallel termination, AC termination, and multipoint termination. For laboratory experiments, 100 feet of 100- Ω , 24-AWG, twisted-pair cable (Bertek) was used. A single driver and receiver, TI AM26LV31C and AM26LV32C, respectively, were tested at room temperature with a 3.3-V supply voltage. The first plot shows output waveforms from the driver at the start of the cable (A/B); the second plot shows input waveforms to the receiver at the far end of the cable (Y).

9.2 Typical Application

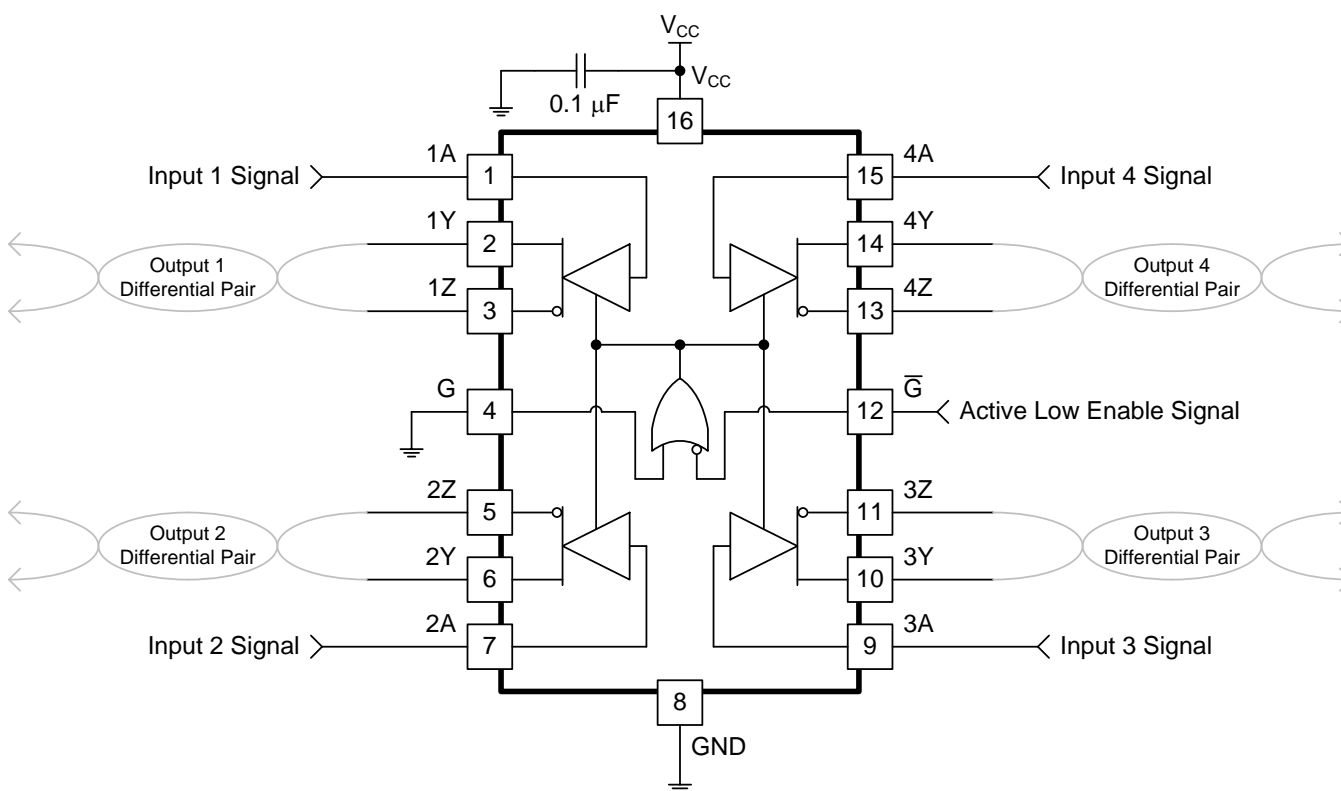

Figure 7. Differential Terminated Configuration With All Channels and Active Low Enable Used

Typical Application (continued)

9.2.1 Design Requirements

Resistor and capacitor (if used) termination values are shown for each laboratory experiment, but vary from system to system. For example, the termination resistor, R_T , must be within 20% of the characteristic impedance, Z_0 , of the cable and can vary from about 80 Ω to 120 Ω .

This example requires the following:

- 3.3-V power source
- RS-485 bus operating at 32 MHz or less
- Connector that ensures the correct polarity for port pins

9.2.2 Detailed Design Procedure

Ensure values in Absolute Maximum Ratings are not exceeded. Supply voltage, V_{IH} , and V_{IL} must comply with Recommended Operating Conditions.

Place the device close to bus connector to keep traces (stub) short to prevent adding reflections to the bus line. If desired, add external fail-safe biasing to ensure 200 mV on the A-B port, if the drive is in high impedance state (see Failsafe in RS-485 data buses).

9.2.3 Application Curves

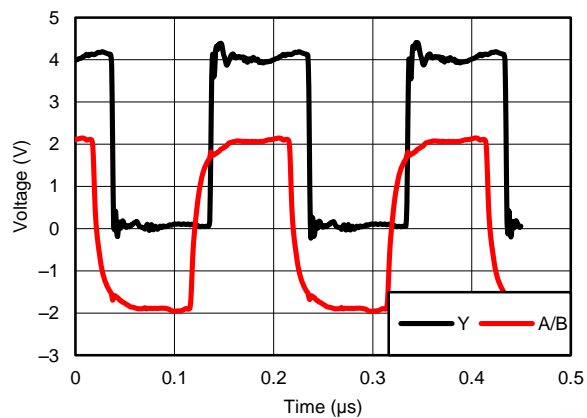

Figure 8. Differential 120- Ω Terminated Output Waveforms (Cat 5E Cable)

10 Power Supply Recommendations

Place a 0.1- μ F bypass capacitors close to the power-supply pins to reduce errors coupling in from noisy or high impedance power supplies.

11 Layout

11.1 Layout Guidelines

For best operational performance of the device, use good PCB layout practices, including:

- Noise can propagate into analog circuitry through the power pins of the circuit as a whole, as well as the operational amplifier. Bypass capacitors are used to reduce the coupled noise by providing low impedance power sources local to the analog circuitry. Connect low-ESR, 0.1- μ F ceramic bypass capacitors between supply pin and ground, placed as close to the device as possible.
- Separate grounding for analog and digital portions of circuitry is one of the simplest and most effective methods of noise suppression. One or more layers on multilayer PCBs are usually devoted to ground planes. A ground plane helps distribute heat and reduces EMI noise pickup. Make sure to physically separate digital and analog grounds, paying attention to the flow of the ground current.
- To reduce parasitic coupling, run the input traces as far away from the supply or output traces as possible. If it is not possible to keep them separate, it is much better to cross the sensitive trace perpendicular as opposed to in parallel with the noisy trace.
- Keep the length of input traces as short as possible. Always remember that the input traces are the most sensitive part of the circuit.
- Consider a driven, low-impedance guard ring around the critical traces. A guard ring can significantly reduce leakage currents from nearby traces that are at different potentials.

11.2 Layout Example

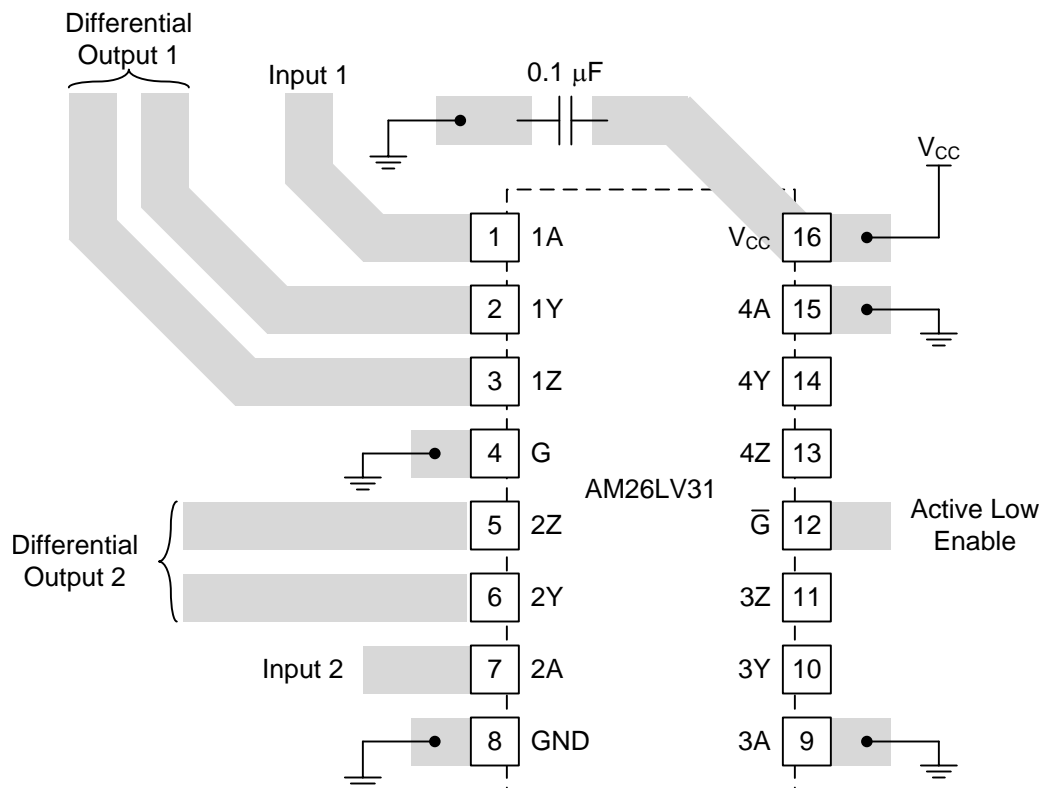

Figure 9. Trace Layout on PCB and Recommendations

12 Device and Documentation Support

12.1 Device Support

12.1.1 Development Support

12.2 Receiving Notification of Documentation Updates

To receive notification of documentation updates, navigate to the device product folder on ti.com. In the upper right corner, click on *Alert me* to register and receive a weekly digest of any product information that has changed. For change details, review the revision history included in any revised document.

12.3 Community Resources

The following links connect to TI community resources. Linked contents are provided "AS IS" by the respective contributors. They do not constitute TI specifications and do not necessarily reflect TI's views; see TI's [Terms of Use](#).

TI E2E™ Online Community *TI's Engineer-to-Engineer (E2E) Community*. Created to foster collaboration among engineers. At e2e.ti.com, you can ask questions, share knowledge, explore ideas and help solve problems with fellow engineers.

Design Support *TI's Design Support* Quickly find helpful E2E forums along with design support tools and contact information for technical support.

12.4 Trademarks

LinIMPACT-C60, E2E are trademarks of Texas Instruments.
All other trademarks are the property of their respective owners.

12.5 Electrostatic Discharge Caution



This integrated circuit can be damaged by ESD. Texas Instruments recommends that all integrated circuits be handled with appropriate precautions. Failure to observe proper handling and installation procedures can cause damage.

ESD damage can range from subtle performance degradation to complete device failure. Precision integrated circuits may be more susceptible to damage because very small parametric changes could cause the device not to meet its published specifications.

12.6 Glossary

SLYZ022 — *TI Glossary*.

This glossary lists and explains terms, acronyms, and definitions.

13 Mechanical, Packaging, and Orderable Information

The following pages include mechanical, packaging, and orderable information. This information is the most current data available for the designated devices. This data is subject to change without notice and revision of this document. For browser-based versions of this data sheet, refer to the left-hand navigation.

PACKAGING INFORMATION

Orderable Device	Status (1)	Package Type	Package Drawing	Pins	Package Qty	Eco Plan (2)	Lead/Ball Finish (6)	MSL Peak Temp (3)	Op Temp (°C)	Device Marking (4/5)	Samples
AM26LV31CD	ACTIVE	SOIC	D	16	40	Green (RoHS & no Sb/Br)	CU NIPDAU	Level-1-260C-UNLIM	0 to 70	AM26LV31C	Samples
AM26LV31CDE4	ACTIVE	SOIC	D	16	40	Green (RoHS & no Sb/Br)	CU NIPDAU	Level-1-260C-UNLIM	0 to 70	AM26LV31C	Samples
AM26LV31CDG4	ACTIVE	SOIC	D	16	40	Green (RoHS & no Sb/Br)	CU NIPDAU	Level-1-260C-UNLIM	0 to 70	AM26LV31C	Samples
AM26LV31CDR	ACTIVE	SOIC	D	16	2500	Green (RoHS & no Sb/Br)	CU NIPDAU CU SN	Level-1-260C-UNLIM	0 to 70	AM26LV31C	Samples
AM26LV31CDRE4	ACTIVE	SOIC	D	16	2500	Green (RoHS & no Sb/Br)	CU NIPDAU	Level-1-260C-UNLIM	0 to 70	AM26LV31C	Samples
AM26LV31CDRG4	ACTIVE	SOIC	D	16	2500	Green (RoHS & no Sb/Br)	CU NIPDAU	Level-1-260C-UNLIM	0 to 70	AM26LV31C	Samples
AM26LV31CNSR	ACTIVE	SO	NS	16	2000	Green (RoHS & no Sb/Br)	CU NIPDAU	Level-1-260C-UNLIM	0 to 70	26LV31	Samples
AM26LV31ID	ACTIVE	SOIC	D	16	40	Green (RoHS & no Sb/Br)	CU NIPDAU	Level-1-260C-UNLIM	-45 to 85	AM26LV311	Samples
AM26LV31IDR	ACTIVE	SOIC	D	16	2500	Green (RoHS & no Sb/Br)	CU NIPDAU	Level-1-260C-UNLIM	-45 to 85	AM26LV311	Samples
AM26LV31INSR	ACTIVE	SO	NS	16	2000	Green (RoHS & no Sb/Br)	CU NIPDAU	Level-1-260C-UNLIM	-45 to 85	26LV311	Samples

(1) The marketing status values are defined as follows:

ACTIVE: Product device recommended for new designs.

LIFEBUY: TI has announced that the device will be discontinued, and a lifetime-buy period is in effect.

NRND: Not recommended for new designs. Device is in production to support existing customers, but TI does not recommend using this part in a new design.

PREVIEW: Device has been announced but is not in production. Samples may or may not be available.

OBSOLETE: TI has discontinued the production of the device.

(2) **RoHS:** TI defines "RoHS" to mean semiconductor products that are compliant with the current EU RoHS requirements for all 10 RoHS substances, including the requirement that RoHS substance do not exceed 0.1% by weight in homogeneous materials. Where designed to be soldered at high temperatures, "RoHS" products are suitable for use in specified lead-free processes. TI may reference these types of products as "Pb-Free".

RoHS Exempt: TI defines "RoHS Exempt" to mean products that contain lead but are compliant with EU RoHS pursuant to a specific EU RoHS exemption.

Green: TI defines "Green" to mean the content of Chlorine (Cl) and Bromine (Br) based flame retardants meet JS709B low halogen requirements of <=1000ppm threshold. Antimony trioxide based flame retardants must also meet the <=1000ppm threshold requirement.

(3) MSL, Peak Temp. - The Moisture Sensitivity Level rating according to the JEDEC industry standard classifications, and peak solder temperature.

(4) There may be additional marking, which relates to the logo, the lot trace code information, or the environmental category on the device.

(5) Multiple Device Markings will be inside parentheses. Only one Device Marking contained in parentheses and separated by a "~" will appear on a device. If a line is indented then it is a continuation of the previous line and the two combined represent the entire Device Marking for that device.

(6) Lead/Ball Finish - Orderable Devices may have multiple material finish options. Finish options are separated by a vertical ruled line. Lead/Ball Finish values may wrap to two lines if the finish value exceeds the maximum column width.

Important Information and Disclaimer:The information provided on this page represents TI's knowledge and belief as of the date that it is provided. TI bases its knowledge and belief on information provided by third parties, and makes no representation or warranty as to the accuracy of such information. Efforts are underway to better integrate information from third parties. TI has taken and continues to take reasonable steps to provide representative and accurate information but may not have conducted destructive testing or chemical analysis on incoming materials and chemicals. TI and TI suppliers consider certain information to be proprietary, and thus CAS numbers and other limited information may not be available for release.

In no event shall TI's liability arising out of such information exceed the total purchase price of the TI part(s) at issue in this document sold by TI to Customer on an annual basis.

TAPE AND REEL INFORMATION

QUADRANT ASSIGNMENTS FOR PIN 1 ORIENTATION IN TAPE

*All dimensions are nominal

Device	Package Type	Package Drawing	Pins	SPQ	Reel Diameter (mm)	Reel Width W1 (mm)	A0 (mm)	B0 (mm)	K0 (mm)	P1 (mm)	W (mm)	Pin1 Quadrant
AM26LV31CDR	SOIC	D	16	2500	330.0	16.4	6.5	10.3	2.1	8.0	16.0	Q1
AM26LV31CDR	SOIC	D	16	2500	330.0	16.8	6.5	10.3	2.1	8.0	16.0	Q1
AM26LV31CDRG4	SOIC	D	16	2500	330.0	16.4	6.5	10.3	2.1	8.0	16.0	Q1
AM26LV31IDR	SOIC	D	16	2500	330.0	16.4	6.5	10.3	2.1	8.0	16.0	Q1
AM26LV31INSR	SO	NS	16	2000	330.0	16.4	8.2	10.5	2.5	12.0	16.0	Q1

TAPE AND REEL BOX DIMENSIONS

*All dimensions are nominal

Device	Package Type	Package Drawing	Pins	SPQ	Length (mm)	Width (mm)	Height (mm)
AM26LV31CDR	SOIC	D	16	2500	333.2	345.9	28.6
AM26LV31CDR	SOIC	D	16	2500	364.0	364.0	27.0
AM26LV31CDRG4	SOIC	D	16	2500	333.2	345.9	28.6
AM26LV31IDR	SOIC	D	16	2500	333.2	345.9	28.6
AM26LV31INSR	SO	NS	16	2000	367.0	367.0	38.0

D (R-PDSO-G16)

PLASTIC SMALL OUTLINE



4040047-6/M 06/11

- NOTES:
- A. All linear dimensions are in inches (millimeters).
 - B. This drawing is subject to change without notice.
 -  C. Body length does not include mold flash, protrusions, or gate burrs. Mold flash, protrusions, or gate burrs shall not exceed 0.006 (0,15) each side.
 -  D. Body width does not include interlead flash. Interlead flash shall not exceed 0.017 (0,43) each side.
 - E. Reference JEDEC MS-012 variation AC.

D (R-PDSO-G16)

PLASTIC SMALL OUTLINE



- NOTES:
- A. All linear dimensions are in millimeters.
 - B. This drawing is subject to change without notice.
 - C. Publication IPC-7351 is recommended for alternate designs.
 - D. Laser cutting apertures with trapezoidal walls and also rounding corners will offer better paste release. Customers should contact their board assembly site for stencil design recommendations. Refer to IPC-7525 for other stencil recommendations.
 - E. Customers should contact their board fabrication site for solder mask tolerances between and around signal pads.

MECHANICAL DATA

NS (R-PDSO-G**)

PLASTIC SMALL-OUTLINE PACKAGE

14-PINS SHOWN



- NOTES:
- A. All linear dimensions are in millimeters.
 - B. This drawing is subject to change without notice.
 - C. Body dimensions do not include mold flash or protrusion, not to exceed 0,15.

IMPORTANT NOTICE

Texas Instruments Incorporated (TI) reserves the right to make corrections, enhancements, improvements and other changes to its semiconductor products and services per JESD46, latest issue, and to discontinue any product or service per JESD48, latest issue. Buyers should obtain the latest relevant information before placing orders and should verify that such information is current and complete.

TI's published terms of sale for semiconductor products (<http://www.ti.com/sc/docs/stdterms.htm>) apply to the sale of packaged integrated circuit products that TI has qualified and released to market. Additional terms may apply to the use or sale of other types of TI products and services.

Reproduction of significant portions of TI information in TI data sheets is permissible only if reproduction is without alteration and is accompanied by all associated warranties, conditions, limitations, and notices. TI is not responsible or liable for such reproduced documentation. Information of third parties may be subject to additional restrictions. Resale of TI products or services with statements different from or beyond the parameters stated by TI for that product or service voids all express and any implied warranties for the associated TI product or service and is an unfair and deceptive business practice. TI is not responsible or liable for any such statements.

Buyers and others who are developing systems that incorporate TI products (collectively, "Designers") understand and agree that Designers remain responsible for using their independent analysis, evaluation and judgment in designing their applications and that Designers have full and exclusive responsibility to assure the safety of Designers' applications and compliance of their applications (and of all TI products used in or for Designers' applications) with all applicable regulations, laws and other applicable requirements. Designer represents that, with respect to their applications, Designer has all the necessary expertise to create and implement safeguards that (1) anticipate dangerous consequences of failures, (2) monitor failures and their consequences, and (3) lessen the likelihood of failures that might cause harm and take appropriate actions. Designer agrees that prior to using or distributing any applications that include TI products, Designer will thoroughly test such applications and the functionality of such TI products as used in such applications.

TI's provision of technical, application or other design advice, quality characterization, reliability data or other services or information, including, but not limited to, reference designs and materials relating to evaluation modules, (collectively, "TI Resources") are intended to assist designers who are developing applications that incorporate TI products; by downloading, accessing or using TI Resources in any way, Designer (individually or, if Designer is acting on behalf of a company, Designer's company) agrees to use any particular TI Resource solely for this purpose and subject to the terms of this Notice.

TI's provision of TI Resources does not expand or otherwise alter TI's applicable published warranties or warranty disclaimers for TI products, and no additional obligations or liabilities arise from TI providing such TI Resources. TI reserves the right to make corrections, enhancements, improvements and other changes to its TI Resources. TI has not conducted any testing other than that specifically described in the published documentation for a particular TI Resource.

Designer is authorized to use, copy and modify any individual TI Resource only in connection with the development of applications that include the TI product(s) identified in such TI Resource. NO OTHER LICENSE, EXPRESS OR IMPLIED, BY ESTOPPEL OR OTHERWISE TO ANY OTHER TI INTELLECTUAL PROPERTY RIGHT, AND NO LICENSE TO ANY TECHNOLOGY OR INTELLECTUAL PROPERTY RIGHT OF TI OR ANY THIRD PARTY IS GRANTED HEREIN, including but not limited to any patent right, copyright, mask work right, or other intellectual property right relating to any combination, machine, or process in which TI products or services are used. Information regarding or referencing third-party products or services does not constitute a license to use such products or services, or a warranty or endorsement thereof. Use of TI Resources may require a license from a third party under the patents or other intellectual property of the third party, or a license from TI under the patents or other intellectual property of TI.

TI RESOURCES ARE PROVIDED "AS IS" AND WITH ALL FAULTS. TI DISCLAIMS ALL OTHER WARRANTIES OR REPRESENTATIONS, EXPRESS OR IMPLIED, REGARDING RESOURCES OR USE THEREOF, INCLUDING BUT NOT LIMITED TO ACCURACY OR COMPLETENESS, TITLE, ANY EPIDEMIC FAILURE WARRANTY AND ANY IMPLIED WARRANTIES OF MERCHANTABILITY, FITNESS FOR A PARTICULAR PURPOSE, AND NON-INFRINGEMENT OF ANY THIRD PARTY INTELLECTUAL PROPERTY RIGHTS. TI SHALL NOT BE LIABLE FOR AND SHALL NOT DEFEND OR INDEMNIFY DESIGNER AGAINST ANY CLAIM, INCLUDING BUT NOT LIMITED TO ANY INFRINGEMENT CLAIM THAT RELATES TO OR IS BASED ON ANY COMBINATION OF PRODUCTS EVEN IF DESCRIBED IN TI RESOURCES OR OTHERWISE. IN NO EVENT SHALL TI BE LIABLE FOR ANY ACTUAL, DIRECT, SPECIAL, COLLATERAL, INDIRECT, PUNITIVE, INCIDENTAL, CONSEQUENTIAL OR EXEMPLARY DAMAGES IN CONNECTION WITH OR ARISING OUT OF TI RESOURCES OR USE THEREOF, AND REGARDLESS OF WHETHER TI HAS BEEN ADVISED OF THE POSSIBILITY OF SUCH DAMAGES.

Unless TI has explicitly designated an individual product as meeting the requirements of a particular industry standard (e.g., ISO/TS 16949 and ISO 26262), TI is not responsible for any failure to meet such industry standard requirements.

Where TI specifically promotes products as facilitating functional safety or as compliant with industry functional safety standards, such products are intended to help enable customers to design and create their own applications that meet applicable functional safety standards and requirements. Using products in an application does not by itself establish any safety features in the application. Designers must ensure compliance with safety-related requirements and standards applicable to their applications. Designer may not use any TI products in life-critical medical equipment unless authorized officers of the parties have executed a special contract specifically governing such use. Life-critical medical equipment is medical equipment where failure of such equipment would cause serious bodily injury or death (e.g., life support, pacemakers, defibrillators, heart pumps, neurostimulators, and implantables). Such equipment includes, without limitation, all medical devices identified by the U.S. Food and Drug Administration as Class III devices and equivalent classifications outside the U.S.

TI may expressly designate certain products as completing a particular qualification (e.g., Q100, Military Grade, or Enhanced Product). Designers agree that it has the necessary expertise to select the product with the appropriate qualification designation for their applications and that proper product selection is at Designers' own risk. Designers are solely responsible for compliance with all legal and regulatory requirements in connection with such selection.

Designer will fully indemnify TI and its representatives against any damages, costs, losses, and/or liabilities arising out of Designer's non-compliance with the terms and provisions of this Notice.

Looking for pricing, stock, or lifecycle information?

Click below to explore more details on WIN SOURCE:

 [View AM26LV31CD](#) on WIN SOURCE

 [Texas Instruments](#) Information

Optimize Your Supply Chain with WIN SOURCE Solutions

-  Global Sourcing Solution
-  Obsolete Management
-  Cost Control Management
-  Shortage Management
-  Alternative Solution
-  Excess Inventory Management