



**THE DATASHEET OF
HCF4067M013TR**





HCF4067B

ANALOG SINGLE 16 CHANNEL MULTIPLEXER/DEMULTIPLEXER

- LOW ON RESISTANCE : 125Ω (Typ.) OVER 15V p-p SIGNAL INPUT RANGE FOR $V_{DD} - V_{SS} = 15V$
- HIGH OFF RESISTANCE : CHANNEL LEAKAGE OF 10pA (Typ.) at $V_{DD} - V_{SS} = 10V$
- MATCHED SWITCH CHARACTERISTICS : $\Delta R_{ON} = 5\Omega$ (Typ.) FOR $V_{DD} - V_{SS} = 15V$
- VERY LOW QUIESCENT POWER DISSIPATION UNDER A DIGITAL CONTROL INPUT AND SUPPLY CONDITIONS : 0.2μW (Typ.) at $V_{DD} - V_{SS} = 10V$
- BINARY ADDRESS DECODING ON CHIP
- QUIESCENT CURRENT SPECIFIED UP TO 20V
- STANDARDIZED SYMMETRICAL OUTPUT CHARACTERISTICS
- 5V, 10V AND 15V PARAMETRIC RATINGS
- INPUT LEAKAGE CURRENT $I_l = 100nA$ (MAX) AT $V_{DD} = 18V$ $T_A = 25^\circ C$
- 100% TESTED FOR QUIESCENT CURRENT
- MEETS ALL REQUIREMENTS OF JEDEC JESD13B "STANDARD SPECIFICATIONS FOR DESCRIPTION OF B SERIES CMOS DEVICES"

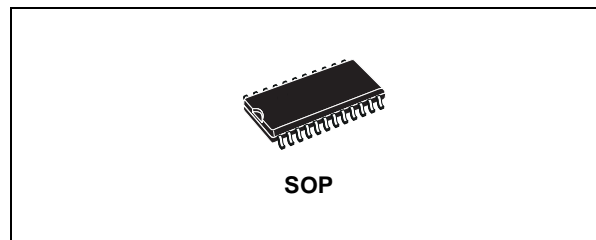

ORDER CODES

PACKAGE	TUBE	T & R
SOP	HCF4067BM1	HCF4067M013TR

HCF4067B, analog multiplexer/demultiplexer CMOS, is a digitally controlled analog switches device having low ON impedance, low OFF leakage current and internal address decoding. In addition, the ON resistance is relatively constant over the full input-signal range.

HCF4067B is a 16-channel multiplexer with four binary control inputs A, B, C, D, and an inhibit input, arranged so that any combination of the inputs selects one switch.

DESCRIPTION

HCF4067B is monolithic integrated circuits fabricated in Metal Oxide Semiconductor technology available in SOP package.

PIN CONNECTION

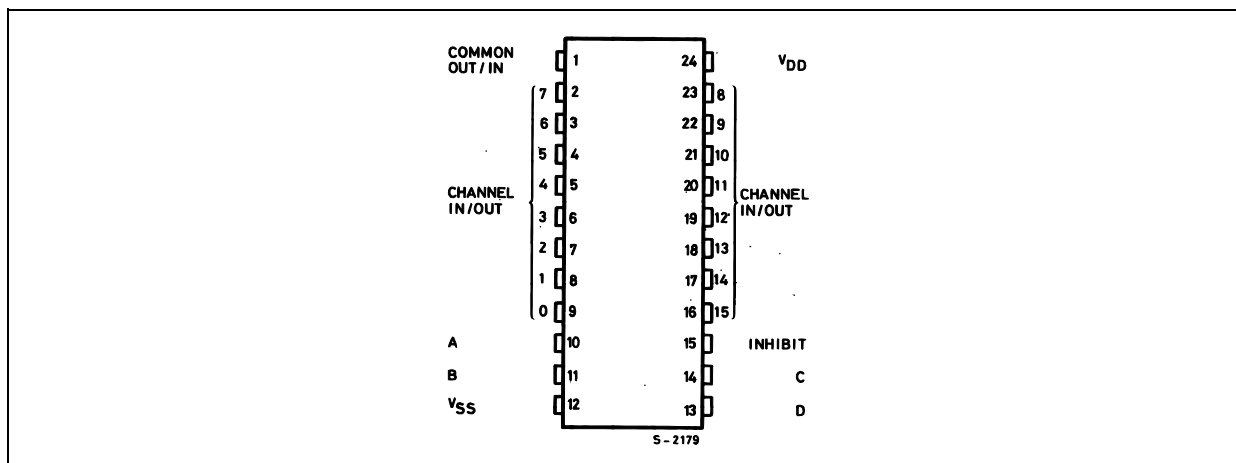

INPUT EQUIVALENT CIRCUIT

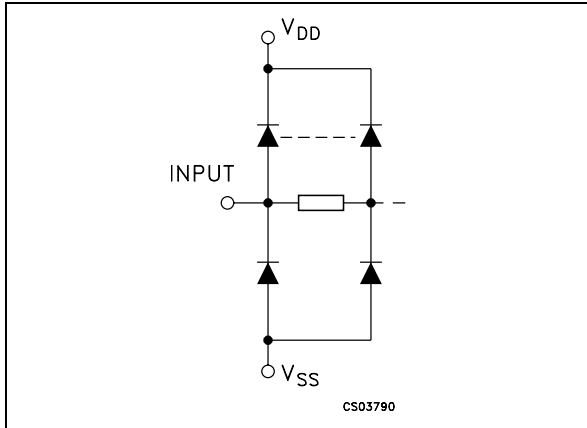

PIN DESCRIPTION

PIN No	SYMBOL	NAME AND FUNCTION
10, 11, 14, 13	A, B, C, D	Binary Control Inputs
1	COMMON OUT/IN	Common Out/In
15	INHIBIT	Inhibit Input
9, 8, 7, 6, 5, 4, 3, 2, 23, 22, 21, 20, 19, 18, 17, 16	0 to 15 CHANNEL IN/OUT	16 channel In/Out
12	V _{SS}	Negative Supply Voltage
24	V _{DD}	Positive Supply Voltage

FUNCTIONAL DIAGRAM

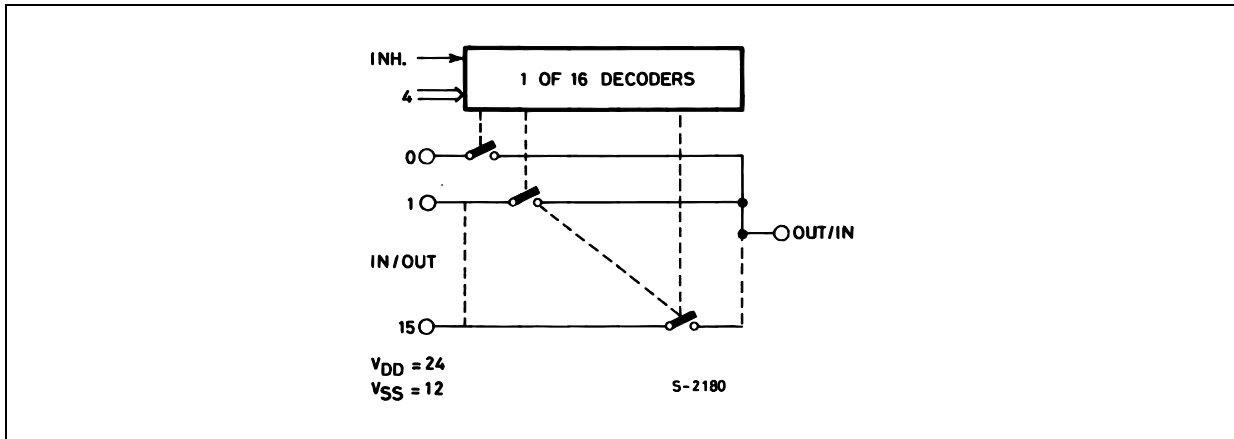

TRUTH TABLE

A	B	C	D	INH	SELECTED CHANNEL
X	X	X	X	H	NONE
L	L	L	L	L	0
H	L	L	L	L	1
L	H	L	L	L	2
H	H	L	L	L	3
L	L	H	L	L	4
H	L	H	L	L	5
L	H	H	L	L	6
H	H	H	L	L	7
L	L	L	H	L	8
H	L	L	H	L	9
L	H	L	H	L	10
H	H	L	H	L	11
L	L	H	H	L	12
H	L	H	H	L	13
L	H	H	H	L	14
H	H	H	H	L	15

LOGIC DIAGRAM

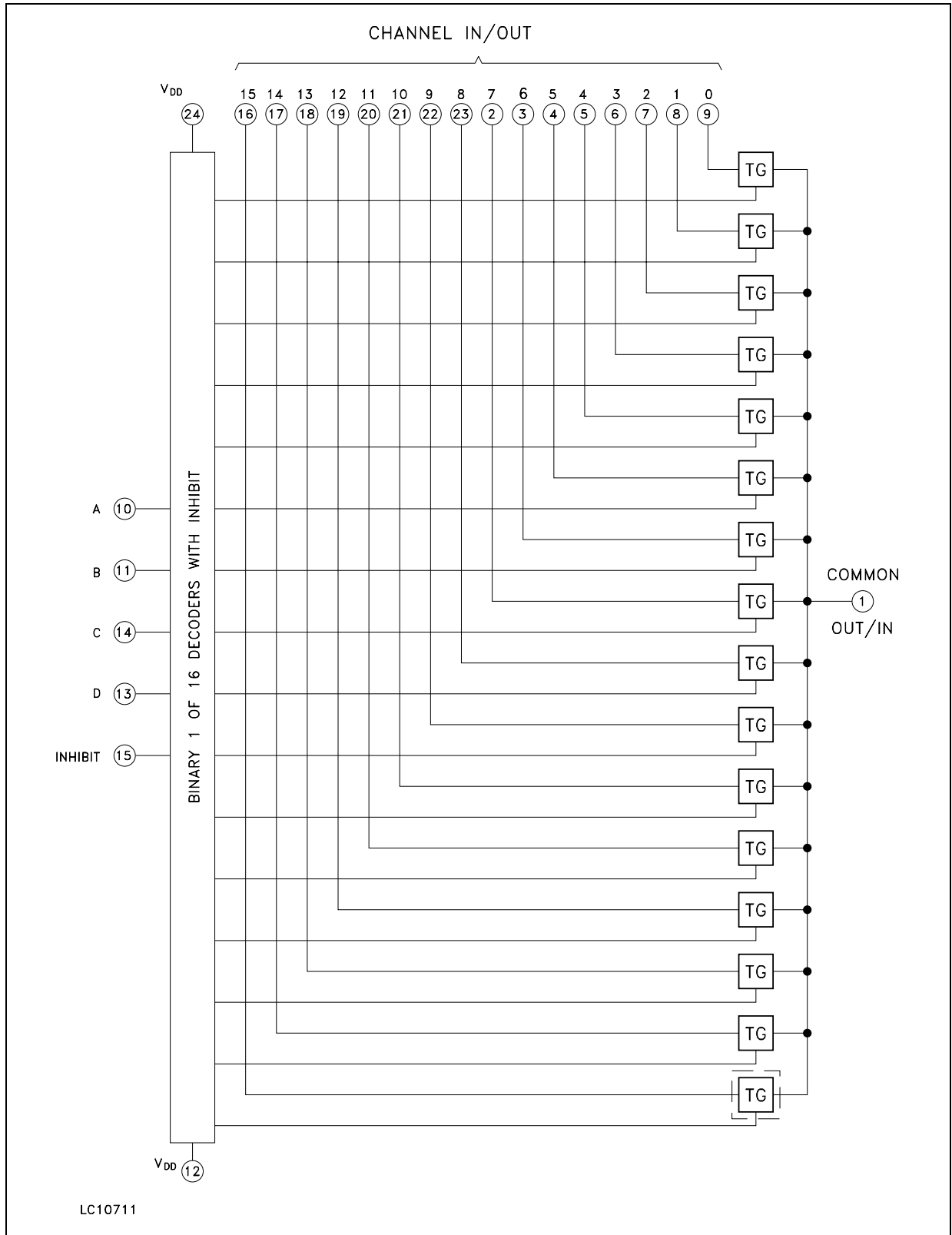

ABSOLUTE MAXIMUM RATINGS

Symbol	Parameter	Value	Unit
V_{DD}	Supply Voltage	-0.5 to +22	V
V_I	DC Input Voltage	-0.5 to $V_{DD} + 0.5$	V
I_I	DC Input Current	± 10	mA
P_D	Power Dissipation per Package	200	mW
	Power Dissipation per Output Transistor	100	mW
T_{op}	Operating Temperature	-55 to +125	°C
T_{stg}	Storage Temperature	-65 to +150	°C

Absolute Maximum Ratings are those values beyond which damage to the device may occur. Functional operation under these conditions is not implied.

All voltage values are referred to V_{SS} pin voltage.

RECOMMENDED OPERATING CONDITIONS

Symbol	Parameter	Value	Unit
V_{DD}	Supply Voltage	3 to 20	V
V_I	Input Voltage	0 to V_{DD}	V
T_{op}	Operating Temperature	-55 to 125	°C

STATIC ELECTRICAL CHARACTERISTICS(T_{amb} = 25°C, Typical temperature coefficient for all V_{DD} value is 0.3 %/°C)

Symbol	Parameter	Test Condition				Value						Unit	
		V _{IS} (V)	V _{EE} (V)	V _{SS} (V)	V _{DD} (V)	T _A = 25°C			-40 to 85°C		-55 to 125°C		
						Min.	Typ.	Max.	Min.	Max.	Min.		Max.
I _L	Quiescent Supply Current				5		0.04	5		150		150	μA
					10		0.04	10		300		300	
					15		0.04	20		600		600	
					20		0.08	100		3000		3000	
SWITCH													
R _{ON}	On Resistance	0 ≤ V _I ≤ V _{DD}	0	0	5		470	1050		1200		1200	Ω
					10		180	400		500		520	
					15		125	240		300		300	
Δ _{ON}	Resistance Δ _{RON} (between any 2 of 4 switches)		0	0	5		10						Ω
					10		10						
					15		5						
OFF (•)	Channel Leakage Current Any Channel Off		0	0	18		±0.1	100		1000		1000	μA
	Channel Leakage Current All Channel Off (Common Out/In)		0	0	18		±0.1	100		1000		1000	
C	Capacitance Input						5						pF
	Output capacitance			-5	5		55						
	Feedthrough						0.2						
CONTROL													
V _{IL}	Input Low Voltage	= V _{DD} thru 1KΩ	V _{EE} = V _{SS} R _L = 1KΩ to V _{SS} I _{IS} < 2μA (on all OFF channels)	5			1.5		1.5		1.5		V
				10			3		3		3		
				15			4		4		4		
V _{IH}	Input High Voltage			5	3.5			3.5		3.5			V
				10	7			7		7			
				15	11			11		11			
I _I	Input Leakage Current		V _I = 0/18V		18		±10 ⁻³	±0.1		±1		±1	μA
C _I	Input Capacitance		Any Address or Inhibit Input				5	7.5					pF

The Noise Margin for both "1" and "0" level is: 1V min. with V_{DD}=5V, 2V min. with V_{DD}=10V, 2.5V min. with V_{DD}=15V

• Determined by minimum feasible leakage measurement for automating testing

DYNAMIC ELECTRICAL CHARACTERISTICS ($T_{amb} = 25^{\circ}C$, $C_L = 50pF$, $R_L = 200K\Omega$, $t_r = t_f = 20 ns$)

Symbol	Parameter	Test Condition						Value*		Unit
		V _C (V)	R _L (K Ω)	f _I (KHz)	V _I (V)	V _{SS} (V)	V _{DD} (V)	Typ.	Max.	
SWITCH										
t _{pd}	Propagation Delay Time (Signal Input to Output)	= V _{DD}	200			0	5 10 15	30 15 11	60 30 20	ns
	Frequency Response Channel "ON" (Sine Wave Input) at $20 \text{ Log } \frac{V_O}{V_I} = -3dB$	= V _{DD}	1		5 (•)	0	10	V _O at Common Out/In 14		ns
	Feedthrough (All channels OFF) at $20 \text{ Log } \frac{V_O}{V_I} = -40dB$	= V _{SS}	1		5 (•)	0	10	V _O at Common Out/In 20		MHz
	Frequency Signal Crosstalk at $20 \text{ Log } \frac{V_{O(A)}}{V_{I(B)}} = -40dB$	V _{C(A)} = V _{DD} V _{C(B)} = V _{SS}	1		5 (•)	0	10	Between Any two (A and B) Channels	1	MHz
t _W	Sine Wave Distortion (f _{IS} = 1KHz sine wave)	5 10 15	10	1	2 (•) 3 (•) 5 (•)	0	5 10 15	0.3 0.2 0.12		%
CONTROL (Address or Inhibit)										
t _{PLH} , t _{PHL}	Propagation Delay Time:Address or Inhibit to Signal OUT (Channel Turning ON)		1			0	5 10 15	325 135 95	650 270 190	ns
t _{PLH} , t _{PHL}	Propagation Delay Time:Address or Inhibit to Signal OUT (Channel Turning OFF)		0.3			0	5 10 15	220 90 65	440 180 130	ns
	Address or Inhibit to Signal Crosstalk		10**			0	10	75		mV peak

(*) Typical temperature coefficient for all V_{DD} value is 0.3 %/°C

(**) : Both Ends of Channel

(•) : Peak to Peak voltage symmetrical about (V_{DD} - V_{SS}) / 2

APPLICATION INFORMATION

In applications where separate power sources are used to drive V_{DD} and the signal inputs, the V_{DD} current capability should exceed V_{DD}/R_L (R_L = effective external load). This provision avoids permanent current flow or clamp action on the V_{DD} supply when power is applied or removed from the HCF4067B.

When switching from one address to another, some of the ON periods of the channels of the multiplexers will overlap momentarily, which may be objectionable in certain applications. Also, when a channel is turned ON or OFF by an address input, there is a momentary conductive path from the channel to V_{SS} , which will dump some charge from any capacitor connected to the input or output of the channel. The inhibit input turning on a channel will similarly dump some charge to V_{SS} .

The amount of charge dumped is mostly a function of the signal level above V_{SS} . Typically, at $V_{DD} - V_{SS} = 10V$, a 100 pF capacitor connected to

the input or output of the channel will lose 3-4% of its voltage at the moment the channel turns ON or OFF. This loss of voltage is essentially independent of the address or inhibit signal transition time, if the transition time is less than 1-2 ms. When the inhibit signal turns a channel off, there is no charge dumping of V_{SS} . Rather, there is a slight rise in the channel voltage level (65 mV typ.) due to the capacitance coupling from inhibit input to channel input or output. Address input also couple some voltage steps onto the channel signal levels.

In certain applications, the external load-resistor current may include both V_{DD} and signal line components. To avoid drawing V_{DD} current when switch current flows into the transmission gate inputs, the voltage drop across the bidirectional switch must not exceed 0.8V (calculated from R_{ON} values shown in ELECTRICAL CHARACTERISTICS CHART). No V_{DD} current will flow through R_L if the switch current flows into terminal 1 on the HCF4067B.

TEST CIRCUIT

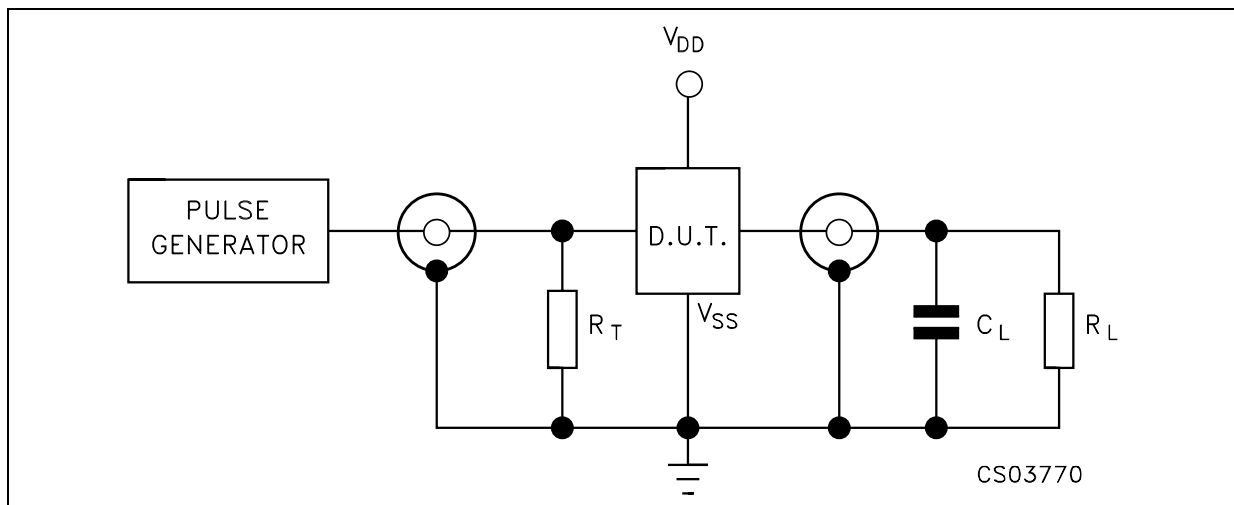

C_L = 50pF or equivalent (includes jig and probe capacitance)
 R_L = 200K Ω
 R_T = Z_{OUT} of pulse generator (typically 50 Ω)

WAVEFORM : PROPAGATION DELAY TIMES (f=1MHz; 50% duty cycle)

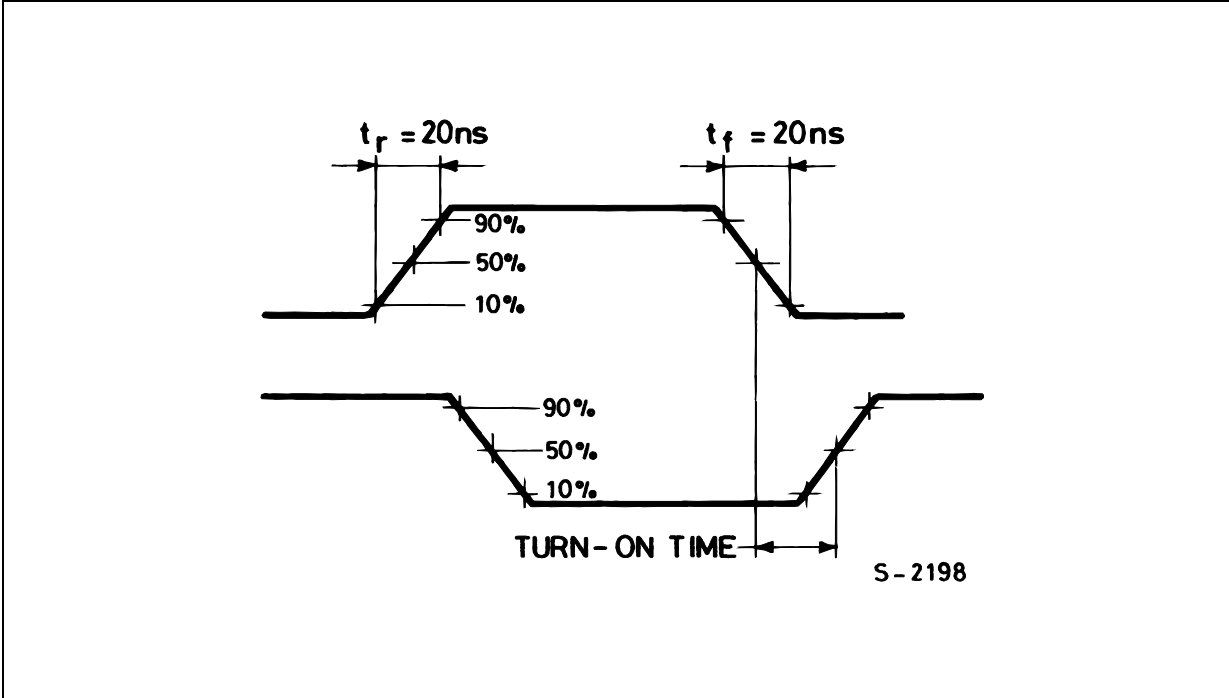

WAVEFORM : PROPAGATION DELAY TIMES (f=1MHz; 50% duty cycle)

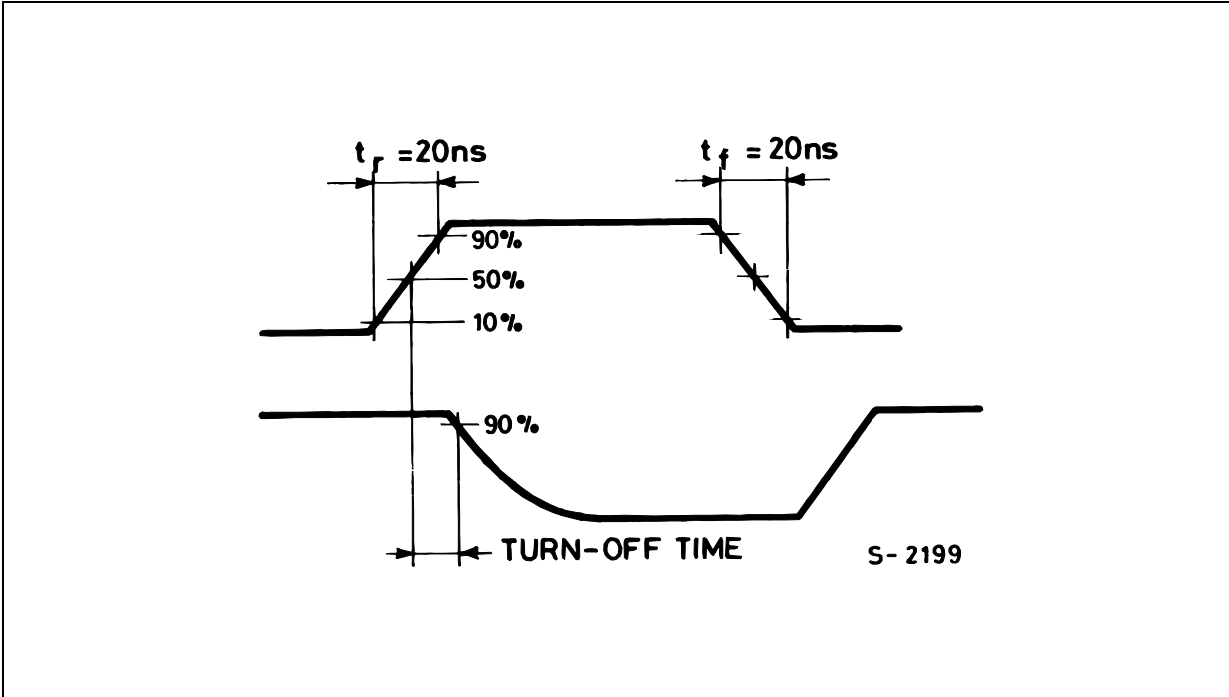

SO-24 MECHANICAL DATA

DIM.	mm.			inch		
	MIN.	TYP	MAX.	MIN.	TYP.	MAX.
A			2.65			0.104
a1	0.1		0.2	0.004		0.008
a2			2.45			0.096
b	0.35		0.49	0.014		0.019
b1	0.23		0.32	0.009		0.012
C		0.5			0.020	
c1	45° (typ.)					
D	15.20		15.60	0.598		0.614
E	10.00		10.65	0.393		0.419
e		1.27			0.050	
e3		13.97			0.550	
F	7.40		7.60	0.291		0.300
L	0.50		1.27	0.020		0.050
S	8° (max.)					

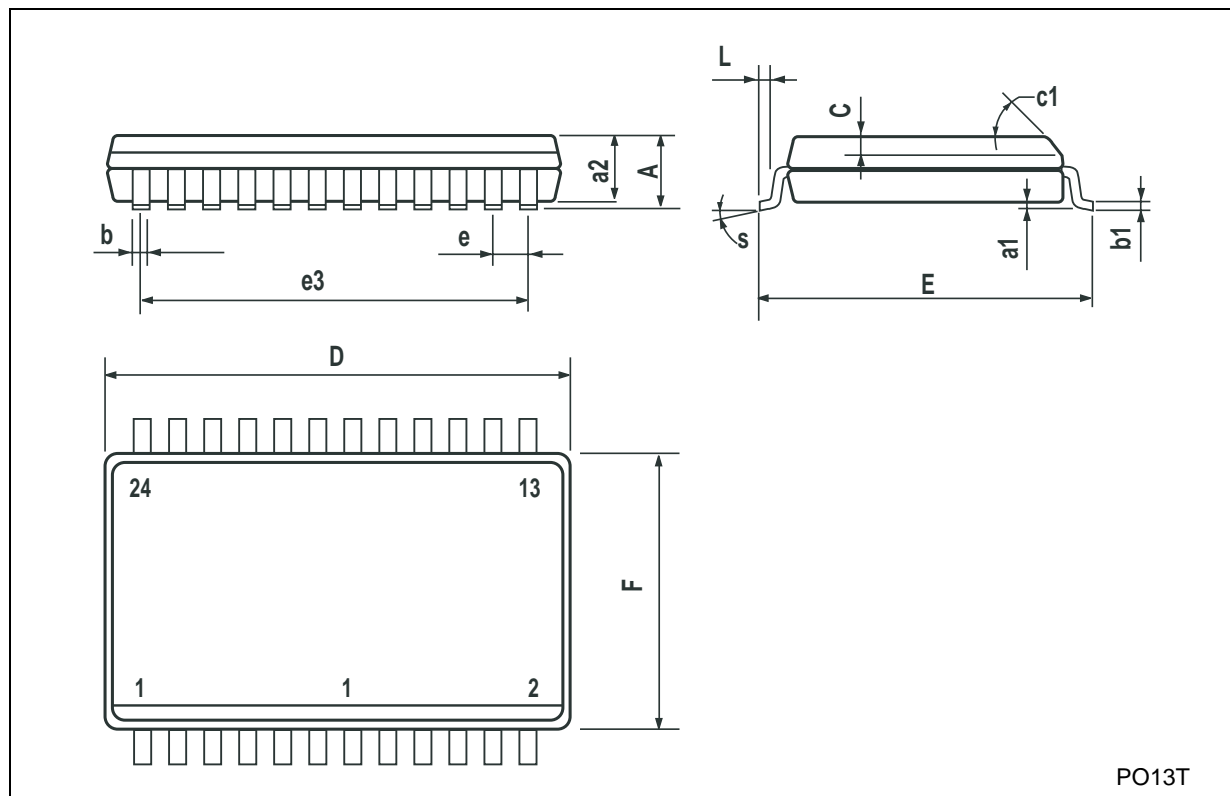

PO13T

Information furnished is believed to be accurate and reliable. However, STMicroelectronics assumes no responsibility for the consequences of use of such information nor for any infringement of patents or other rights of third parties which may result from its use. No license is granted by implication or otherwise under any patent or patent rights of STMicroelectronics. Specifications mentioned in this publication are subject to change without notice. This publication supersedes and replaces all information previously supplied. STMicroelectronics products are not authorized for use as critical components in life support devices or systems without express written approval of STMicroelectronics.

© The ST logo is a registered trademark of STMicroelectronics



© 2002 STMicroelectronics - Printed in Italy - All Rights Reserved
STMicroelectronics GROUP OF COMPANIES

Australia - Brazil - Canada - China - Finland - France - Germany - Hong Kong - India - Israel - Italy - Japan - Malaysia - Malta - Morocco
Singapore - Spain - Sweden - Switzerland - United Kingdom - United States.

© <http://www.st.com>

Looking for pricing, stock, or lifecycle information?

Click below to explore more details on WIN SOURCE:

-  [View HCF4067M013TR](#) on WIN SOURCE
-  [STMicroelectronics](#) Information

Optimize Your Supply Chain with WIN SOURCE Solutions

-  Global Sourcing Solution
-  Obsolete Management
-  Cost Control Management
-  Shortage Management
-  Alternative Solution
-  Excess Inventory Management