



**THE DATASHEET OF  
ADG5234BRUZ-RL7**



## FEATURES

- Latch-up proof
- 2.8 pF off source capacitance
- 9 pF off drain capacitance
- 0.4 pC charge injection
- Low on resistance: 160  $\Omega$  typical
- $\pm 9$  V to  $\pm 22$  V dual-supply operation
- 9 V to 40 V single-supply operation
- 48 V supply maximum ratings
- Fully specified at  $\pm 15$  V,  $\pm 20$  V, +12 V, and +36 V
- $V_{DD}$  to  $V_{SS}$  analog signal range
- Human body model (HBM) ESD rating
  - 8 kV input/output port to supplies
  - 2 kV input/output port to input/output port
  - 8 kV all other pins

## APPLICATIONS

- Automatic test equipment
- Data acquisition
- Instrumentation
- Avionics
- Audio and video switching
- Communication systems

## GENERAL DESCRIPTION

The [ADG5233](#) and [ADG5234](#) are monolithic industrial CMOS analog switches comprising three independently selectable single-pole, double throw (SPDT) switches and four independently selectable SPDT switches, respectively.

All channels exhibit break-before-make switching action that prevents momentary shorting when switching channels. An  $\overline{EN}$  input on the [ADG5233](#) (LFCSP and TSSOP packages) is used to enable or disable the device. When disabled, all channels are switched off.

The ultralow capacitance and charge injection of these switches make them ideal solutions for data acquisition and sample-and-hold applications, where low glitch and fast settling are required. Fast switching speed coupled with high signal bandwidth make these devices suitable for video signal switching.

## FUNCTIONAL BLOCK DIAGRAMS

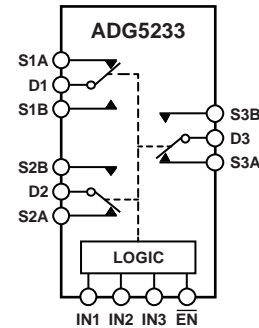

Figure 1. [ADG5233](#) TSSOP and LFCSP\_WQ

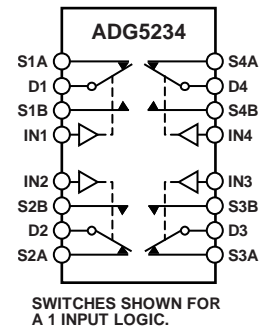

Figure 2. [ADG5234](#) TSSOP and LFCSP\_WQ

## PRODUCT HIGHLIGHTS

1. Trench Isolation Guards Against Latch-Up.  
A dielectric trench separates the P and N channel transistors thereby preventing latch-up even under severe overvoltage conditions.
2. Ultralow Capacitance and 0.4 pC Charge Injection.
3. Dual-Supply Operation.  
For applications where the analog signal is bipolar, the [ADG5233/ADG5234](#) can be operated from dual supplies up to  $\pm 22$  V.
4. Single-Supply Operation.  
For applications where the analog signal is unipolar, the [ADG5233/ADG5234](#) can be operated from a single-rail power supply up to 40 V.
5. 3 V Logic-Compatible Digital Inputs.  
 $V_{INH} = 2.0$  V,  $V_{INL} = 0.8$  V.
6. No  $V_L$  Logic Power Supply Required.

Rev. D

[Document Feedback](#)

Information furnished by Analog Devices is believed to be accurate and reliable. However, no responsibility is assumed by Analog Devices for its use, nor for any infringements of patents or other rights of third parties that may result from its use. Specifications subject to change without notice. No license is granted by implication or otherwise under any patent or patent rights of Analog Devices. Trademarks and registered trademarks are the property of their respective owners.

## TABLE OF CONTENTS

Features .....	1	Continuous Current per Channel, Sx or Dx.....	7
Applications.....	1	Absolute Maximum Ratings .....	9
Functional Block Diagrams.....	1	ESD Caution.....	9
General Description .....	1	Pin Configurations and Function Descriptions .....	10
Product Highlights .....	1	Typical Performance Characteristics .....	12
Revision History .....	2	Test Circuits.....	16
Specifications.....	3	Terminology .....	18
±15 V Dual Supply .....	3	Trench Isolation.....	19
±20 V Dual Supply .....	4	Applications Information .....	20
12 V Single Supply.....	5	Outline Dimensions .....	21
36 V Single Supply.....	6	Ordering Guide .....	22

## REVISION HISTORY

### 8/15—Rev. C to Rev. D

Changes to Features Section.....	1
Changes to Table 1.....	3
Changes to Table 2.....	4
Changes to Table 3.....	5
Changes to Table 4.....	6
Changes to Table 7.....	9
Changes to Figure 20 Caption to Figure 22 Caption .....	14
Changes to Figure 23 Caption to Figure 25 Caption .....	15
Deleted Figure 20 and Figure 22; Renumbered Sequentially ...	15
Deleted Figure 24, Figure 26, and Figure 28 .....	16
Deleted Figure 30.....	17

### 12/14—Rev. B to Rev. C

Changes to Features Section and Product Highlights Section ...	1
Changes to Table 1.....	3
Changes to Table 2.....	4
Changes to Table 3.....	6
Changes to Table 4.....	7
Change to Table 7 .....	9
Changes to Figure 7 to Figure 12.....	13
Changes to Figure 13 and Figure 14.....	14
Changes to Figure 19, Figure 20 Caption, and Figure 22 Caption .....	15
Added Figure 21 and Figure 23; Renumbered Sequentially ....	15
Changes to Figure 24 Caption, Figure 26 Caption, and Figure 28 Caption .....	16
Added Figure 25, Figure 27, and Figure 28.....	16
Changes Figure 30 Caption .....	17
Added Figure 31.....	17
Changes to Figure 34.....	18

### 6/13—Rev. A to Rev. B

Added 20-Lead LFCSP .....	Universal
Updated Outline Dimensions .....	21
Changes to Ordering Guide .....	22

### 3/12—Rev. 0 to Rev. A

Added 16-Lead LFCSP .....	Universal
Changes to Ordering Guide .....	22

### 7/11—Revision 0: Initial Version

## SPECIFICATIONS

## ±15 V DUAL SUPPLY

$V_{DD} = +15\text{ V} \pm 10\%$ ,  $V_{SS} = -15\text{ V} \pm 10\%$ ,  $GND = 0\text{ V}$ , unless otherwise noted.

Table 1.

Parameter	25°C	-40°C to +85°C	-40°C to +125°C	Unit	Test Conditions/Comments
<b>ANALOG SWITCH</b>					
Analog Signal Range			$V_{DD}$ to $V_{SS}$	V	
On Resistance, $R_{ON}$	160			$\Omega$ typ	$V_S = \pm 10\text{ V}$ , $I_S = -1\text{ mA}$ ; see Figure 28
On-Resistance Match Between Channels, $\Delta R_{ON}$	200	250	280	$\Omega$ max	$V_{DD} = +13.5\text{ V}$ , $V_{SS} = -13.5\text{ V}$ $V_S = \pm 10\text{ V}$ , $I_S = -1\text{ mA}$
On-Resistance Flatness, $R_{FLAT(ON)}$	3.5			$\Omega$ typ	
	8	9	10	$\Omega$ max	
	38			$\Omega$ typ	$V_S = \pm 10\text{ V}$ , $I_S = -1\text{ mA}$
	50	65	70	$\Omega$ max	
<b>LEAKAGE CURRENTS</b>					
Source Off Leakage, $I_S$ (Off)	$\pm 0.02$			nA typ	$V_{DD} = +16.5\text{ V}$ , $V_{SS} = -16.5\text{ V}$ $V_S = \pm 10\text{ V}$ , $V_D = \mp 10\text{ V}$ ; see Figure 30
Drain Off Leakage, $I_D$ (Off)	$\pm 0.1$	$\pm 0.2$	$\pm 0.4$	nA max	
	$\pm 0.02$			nA typ	$V_S = \pm 10\text{ V}$ , $V_D = \mp 10\text{ V}$ ; see Figure 30
Channel On Leakage, $I_D$ (On), $I_S$ (On)	$\pm 0.1$	$\pm 0.2$	$\pm 0.4$	nA max	
	$\pm 0.08$			nA typ	$V_S = V_D = \pm 10\text{ V}$ ; see Figure 26
	$\pm 0.2$	$\pm 0.3$	$\pm 0.9$	nA max	
<b>DIGITAL INPUTS</b>					
Input High Voltage, $V_{INH}$			2.0	V min	
Input Low Voltage, $V_{INL}$			0.8	V max	
Input Current, $I_{INL}$ or $I_{INH}$	0.002			$\mu\text{A}$ typ	$V_{IN} = V_{GND}$ or $V_{DD}$
			$\pm 0.1$	$\mu\text{A}$ max	
Digital Input Capacitance, $C_{IN}$	3			pF typ	
<b>DYNAMIC CHARACTERISTICS<sup>1</sup></b>					
Transition Time, $t_{TRANSITION}$	125			ns typ	$R_L = 300\ \Omega$ , $C_L = 35\text{ pF}$
	160	190	215	ns max	$V_S = 10\text{ V}$ ; see Figure 33
$t_{ON}(\overline{EN})$	145			ns typ	$R_L = 300\ \Omega$ , $C_L = 35\text{ pF}$
	175	210	240	ns max	$V_S = 10\text{ V}$ ; see Figure 35
$t_{OFF}(\overline{EN})$	125			ns typ	$R_L = 300\ \Omega$ , $C_L = 35\text{ pF}$
	155	170	180	ns max	$V_S = 10\text{ V}$ ; see Figure 35
Break-Before-Make Time Delay, $t_D$	45			ns typ	$R_L = 300\ \Omega$ , $C_L = 35\text{ pF}$
			25	ns min	$V_{S1} = V_{S2} = 10\text{ V}$ ; see Figure 34
Charge Injection, $Q_{INJ}$	0.4			pC typ	$V_S = 0\text{ V}$ , $R_S = 0\ \Omega$ , $C_L = 1\text{ nF}$ ; see Figure 36
Off Isolation	-76			dB typ	$R_L = 50\ \Omega$ , $C_L = 5\text{ pF}$ , $f = 1\text{ MHz}$ ; see Figure 31
Channel-to-Channel Crosstalk	-87			dB typ	$R_L = 50\ \Omega$ , $C_L = 5\text{ pF}$ , $f = 1\text{ MHz}$ ; Figure 29
-3 dB Bandwidth	355			MHz typ	$R_L = 50\ \Omega$ , $C_L = 5\text{ pF}$ ; see Figure 32
Insertion Loss	-6.4			dB typ	$R_L = 50\ \Omega$ , $C_L = 5\text{ pF}$ , $f = 1\text{ MHz}$ ; see Figure 32
$C_S$ (Off)	2.8			pF typ	$V_S = 0\text{ V}$ , $f = 1\text{ MHz}$
$C_D$ (Off)	9			pF typ	$V_S = 0\text{ V}$ , $f = 1\text{ MHz}$
$C_D$ (On), $C_S$ (On)	13			pF typ	$V_S = 0\text{ V}$ , $f = 1\text{ MHz}$

Parameter	25°C	-40°C to +85°C	-40°C to +125°C	Unit	Test Conditions/Comments
<b>POWER REQUIREMENTS</b>					
$I_{DD}$	45			$\mu\text{A typ}$	$V_{DD} = +16.5\text{ V}, V_{SS} = -16.5\text{ V}$ Digital inputs = 0 V or $V_{DD}$
$I_{SS}$	55		70	$\mu\text{A max}$	
	0.001			$\mu\text{A typ}$	Digital inputs = 0 V or $V_{DD}$
			1	$\mu\text{A max}$	
$V_{DD}/V_{SS}$			$\pm 9/\pm 22$	V min/V max	GND = 0 V

<sup>1</sup> Guaranteed by design; not subject to production test.

## ±20 V DUAL SUPPLY

$V_{DD} = +20\text{ V} \pm 10\%$ ,  $V_{SS} = -20\text{ V} \pm 10\%$ , GND = 0 V, unless otherwise noted.

**Table 2.**

Parameter	25°C	-40°C to +85°C	-40°C to +125°C	Unit	Test Conditions/Comments
<b>ANALOG SWITCH</b>					
Analog Signal Range			$V_{DD}$ to $V_{SS}$	V	
On Resistance, $R_{ON}$	140			$\Omega$ typ	$V_S = \pm 15\text{ V}, I_S = -1\text{ mA}$ ; see Figure 28
	160	200	230	$\Omega$ max	$V_{DD} = +18\text{ V}, V_{SS} = -18\text{ V}$
On-Resistance Match Between Channels, $\Delta R_{ON}$	3.5			$\Omega$ typ	$V_S = \pm 15\text{ V}, I_S = -1\text{ mA}$
	8	9	10	$\Omega$ max	
On-Resistance Flatness, $R_{FLAT(ON)}$	33			$\Omega$ typ	$V_S = \pm 15\text{ V}, I_S = -1\text{ mA}$
	45	55	60	$\Omega$ max	
<b>LEAKAGE CURRENTS</b>					
Source Off Leakage, $I_S$ (Off)	$\pm 0.02$			nA typ	$V_{DD} = +22\text{ V}, V_{SS} = -22\text{ V}$ $V_S = \pm 15\text{ V}, V_D = \mp 15\text{ V}$ ; see Figure 30
	$\pm 0.1$	$\pm 0.2$	$\pm 0.4$	nA max	
Drain Off Leakage, $I_D$ (Off)	$\pm 0.02$			nA typ	$V_S = \pm 15\text{ V}, V_D = \mp 15\text{ V}$ ; see Figure 30
	$\pm 0.1$	$\pm 0.2$	$\pm 0.4$	nA max	
Channel On Leakage, $I_D$ (On), $I_S$ (On)	$\pm 0.08$			nA typ	$V_S = V_D = \pm 15\text{ V}$ ; see Figure 26
	$\pm 0.2$	$\pm 0.3$	$\pm 0.9$	nA max	
<b>DIGITAL INPUTS</b>					
Input High Voltage, $V_{INH}$			2.0	V min	
Input Low Voltage, $V_{INL}$			0.8	V max	
Input Current, $I_{INL}$ or $I_{INH}$	0.002			$\mu\text{A typ}$	$V_{IN} = V_{GND}$ or $V_{DD}$
			$\pm 0.1$	$\mu\text{A max}$	
Digital Input Capacitance, $C_{IN}$	3			pF typ	
<b>DYNAMIC CHARACTERISTICS<sup>1</sup></b>					
Transition Time, $t_{TRANSITION}$	125			ns typ	$R_L = 300\ \Omega, C_L = 35\text{ pF}$
	155	180	200	ns max	$V_S = 10\text{ V}$ ; see Figure 33
$t_{ON}(\overline{EN})$	145			ns typ	$R_L = 300\ \Omega, C_L = 35\text{ pF}$
	170	200	220	ns max	$V_S = 10\text{ V}$ ; see Figure 35
$t_{OFF}(\overline{EN})$	125			ns typ	$R_L = 300\ \Omega, C_L = 35\text{ pF}$
	155	160	170	ns max	$V_S = 10\text{ V}$ ; see Figure 35
Break-Before-Make Time Delay, $t_D$	40			ns typ	$R_L = 300\ \Omega, C_L = 35\text{ pF}$
			20	ns min	$V_{S1} = V_{S2} = 10\text{ V}$ ; see Figure 34
Charge Injection, $Q_{INJ}$	0.7			pC typ	$V_S = 0\text{ V}, R_S = 0\ \Omega, C_L = 1\text{ nF}$ ; see Figure 36
Off Isolation	-76			dB typ	$R_L = 50\ \Omega, C_L = 5\text{ pF}, f = 1\text{ MHz}$ ; see Figure 31

Parameter	25°C	-40°C to +85°C	-40°C to +125°C	Unit	Test Conditions/Comments
Channel-to-Channel Crosstalk	-87			dB typ	$R_L = 50\ \Omega$ , $C_L = 5\ \text{pF}$ , $f = 1\ \text{MHz}$ ; see Figure 29
-3 dB Bandwidth	370			MHz typ	$R_L = 50\ \Omega$ , $C_L = 5\ \text{pF}$ ; see Figure 32
Insertion Loss	-5.6			dB typ	$R_L = 50\ \Omega$ , $C_L = 5\ \text{pF}$ , $f = 1\ \text{MHz}$ ; see Figure 32
$C_S$ (Off)	2.8			pF typ	$V_S = 0\ \text{V}$ , $f = 1\ \text{MHz}$
$C_D$ (Off)	9			pF typ	$V_S = 0\ \text{V}$ , $f = 1\ \text{MHz}$
$C_D$ (On), $C_S$ (On)	13			pF typ	$V_S = 0\ \text{V}$ , $f = 1\ \text{MHz}$
<b>POWER REQUIREMENTS</b>					$V_{DD} = +22\ \text{V}$ , $V_{SS} = -22\ \text{V}$
$I_{DD}$	50			$\mu\text{A}$ typ	Digital inputs = 0 V or $V_{DD}$
	70		110	$\mu\text{A}$ max	
$I_{SS}$	0.001			$\mu\text{A}$ typ	Digital inputs = 0 V or $V_{DD}$
			1	$\mu\text{A}$ max	
$V_{DD}/V_{SS}$			$\pm 9/\pm 22$	V min/V max	GND = 0 V

<sup>1</sup> Guaranteed by design; not subject to production test.

## 12 V SINGLE SUPPLY

$V_{DD} = 12\ \text{V} \pm 10\%$ ,  $V_{SS} = 0\ \text{V}$ , GND = 0 V, unless otherwise noted.

Table 3.

Parameter	25°C	-40°C to +85°C	-40°C to +125°C	Unit	Test Conditions/Comments
<b>ANALOG SWITCH</b>					
Analog Signal Range			0 V to $V_{DD}$	V	
On Resistance, $R_{ON}$	360			$\Omega$ typ	$V_S = 0\ \text{V}$ to 10 V, $I_S = -1\ \text{mA}$ ; see Figure 28
	500	610	700	$\Omega$ max	$V_{DD} = 10.8\ \text{V}$ , $V_{SS} = 0\ \text{V}$
On-Resistance Match Between Channels, $\Delta R_{ON}$	5.5			$\Omega$ typ	$V_S = 0\ \text{V}$ to 10 V, $I_S = -1\ \text{mA}$
	20	21	22	$\Omega$ max	
On-Resistance Flatness, $R_{FLAT(ON)}$	170			$\Omega$ typ	$V_S = 0\ \text{V}$ to 10 V, $I_S = -1\ \text{mA}$
	280	335	370	$\Omega$ max	
<b>LEAKAGE CURRENTS</b>					
Source Off Leakage, $I_S$ (Off)	$\pm 0.02$			nA typ	$V_{DD} = 13.2\ \text{V}$ , $V_{SS} = 0\ \text{V}$ $V_S = 1\ \text{V}/10\ \text{V}$ , $V_D = 10\ \text{V}/1\ \text{V}$ ; see Figure 30
	$\pm 0.1$	$\pm 0.2$	$\pm 0.4$	nA max	
Drain Off Leakage, $I_D$ (Off)	$\pm 0.02$			nA typ	$V_S = 1\ \text{V}/10\ \text{V}$ , $V_D = 10\ \text{V}/1\ \text{V}$ ; see Figure 30
	$\pm 0.1$	$\pm 0.2$	$\pm 0.4$	nA max	
Channel On Leakage, $I_D$ (On), $I_S$ (On)	$\pm 0.08$			nA typ	$V_S = V_D = 1\ \text{V}/10\ \text{V}$ ; see Figure 26
	$\pm 0.2$	$\pm 0.3$	$\pm 0.9$	nA max	
<b>DIGITAL INPUTS</b>					
Input High Voltage, $V_{INH}$			2.0	V min	
Input Low Voltage, $V_{INL}$			0.8	V max	
Input Current, $I_{INL}$ or $I_{INH}$	0.002			$\mu\text{A}$ typ	$V_{IN} = V_{GND}$ or $V_{DD}$
			$\pm 0.1$	$\mu\text{A}$ max	
Digital Input Capacitance, $C_{IN}$	3			pF typ	

Parameter	25°C	-40°C to +85°C	-40°C to +125°C	Unit	Test Conditions/Comments
<b>DYNAMIC CHARACTERISTICS<sup>1</sup></b>					
Transition Time, $t_{\text{TRANSITION}}$	165			ns typ	$R_L = 300\ \Omega$ , $C_L = 35\ \text{pF}$
$t_{\text{ON}}(\overline{\text{EN}})$	215	260	300	ns max	$V_S = 8\ \text{V}$ ; see Figure 33
	200			ns typ	$R_L = 300\ \Omega$ , $C_L = 35\ \text{pF}$
$t_{\text{OFF}}(\overline{\text{EN}})$	245	305	350	ns max	$V_S = 8\ \text{V}$ ; see Figure 35
	130			ns typ	$R_L = 300\ \Omega$ , $C_L = 35\ \text{pF}$
Break-Before-Make Time Delay, $t_D$	165	180	200	ns max	$V_S = 8\ \text{V}$ ; see Figure 35
	85			ns typ	$R_L = 300\ \Omega$ , $C_L = 35\ \text{pF}$
Charge Injection, $Q_{\text{INJ}}$			45	ns min	$V_{S1} = V_{S2} = 8\ \text{V}$ ; see Figure 34
	0			pC typ	$V_S = 6\ \text{V}$ , $R_S = 0\ \Omega$ , $C_L = 1\ \text{nF}$ ; see Figure 36
Off Isolation	-76			dB typ	$R_L = 50\ \Omega$ , $C_L = 5\ \text{pF}$ , $f = 1\ \text{MHz}$ ; see Figure 31
Channel-to-Channel Crosstalk	-87			dB typ	$R_L = 50\ \Omega$ , $C_L = 5\ \text{pF}$ , $f = 1\ \text{MHz}$ ; see Figure 29
-3 dB Bandwidth	260			MHz typ	$R_L = 50\ \Omega$ , $C_L = 5\ \text{pF}$ ; see Figure 32
Insertion Loss	-9			dB typ	$R_L = 50\ \Omega$ , $C_L = 5\ \text{pF}$ , $f = 1\ \text{MHz}$ ; see Figure 32
$C_S$ (Off)	3			pF typ	$V_S = 6\ \text{V}$ , $f = 1\ \text{MHz}$
$C_D$ (Off)	10			pF typ	$V_S = 6\ \text{V}$ , $f = 1\ \text{MHz}$
$C_D$ (On), $C_S$ (On)	14			pF typ	$V_S = 6\ \text{V}$ , $f = 1\ \text{MHz}$
<b>POWER REQUIREMENTS</b>					
$I_{\text{DD}}$	40			$\mu\text{A}$ typ	$V_{\text{DD}} = 13.2\ \text{V}$
	50		65	$\mu\text{A}$ max	Digital inputs = 0 V or $V_{\text{DD}}$
$V_{\text{DD}}$			9/40	V min/V max	GND = 0 V, $V_{\text{SS}} = 0\ \text{V}$

<sup>1</sup> Guaranteed by design; not subject to production test.

**36 V SINGLE SUPPLY**

$V_{\text{DD}} = 36\ \text{V} \pm 10\%$ ,  $V_{\text{SS}} = 0\ \text{V}$ , GND = 0 V, unless otherwise noted.

Table 4.

Parameter	25°C	-40°C to +85°C	-40°C to +125°C	Unit	Test Conditions/Comments
<b>ANALOG SWITCH</b>					
Analog Signal Range			0 V to $V_{\text{DD}}$	V	
On Resistance, $R_{\text{ON}}$	140			$\Omega$ typ	$V_S = 0\ \text{V}$ to 30 V, $I_S = -1\ \text{mA}$ ; see Figure 28
	170	215	245	$\Omega$ max	$V_{\text{DD}} = 32.4\ \text{V}$ , $V_{\text{SS}} = 0\ \text{V}$
On-Resistance Match Between Channels, $\Delta R_{\text{ON}}$	3.5			$\Omega$ typ	$V_S = 0\ \text{V}$ to 30 V, $I_S = -1\ \text{mA}$
	8	9	10	$\Omega$ max	
On-Resistance Flatness, $R_{\text{FLAT}}(\text{ON})$	35			$\Omega$ typ	$V_S = 0\ \text{V}$ to 30 V, $I_S = -1\ \text{mA}$
	50	60	65	$\Omega$ max	
<b>LEAKAGE CURRENTS</b>					
Source Off Leakage, $I_S$ (Off)	$\pm 0.02$			nA typ	$V_{\text{DD}} = 39.6\ \text{V}$ , $V_{\text{SS}} = 0\ \text{V}$ $V_S = 1\ \text{V}/30\ \text{V}$ , $V_D = 30\ \text{V}/1\ \text{V}$ ; see Figure 30
Drain Off Leakage, $I_D$ (Off)	$\pm 0.1$	$\pm 0.2$	$\pm 0.4$	nA max	
	$\pm 0.02$			nA typ	$V_S = 1\ \text{V}/30\ \text{V}$ , $V_D = 30\ \text{V}/1\ \text{V}$ ; see Figure 30
Channel On Leakage, $I_D$ (On), $I_S$ (On)	$\pm 0.1$	$\pm 0.2$	$\pm 0.4$	nA max	
	$\pm 0.08$			nA typ	$V_S = V_D = 1\ \text{V}/30\ \text{V}$ ; see Figure 26
	$\pm 0.2$	$\pm 0.3$	$\pm 0.9$	nA max	

Parameter	25°C	−40°C to +85°C	−40°C to +125°C	Unit	Test Conditions/Comments
<b>DIGITAL INPUTS</b>					
Input High Voltage, $V_{INH}$			2.0	V min	$V_{IN} = V_{GND}$ or $V_{DD}$
Input Low Voltage, $V_{INL}$			0.8	V max	
Input Current, $I_{INL}$ or $I_{INH}$	0.002			$\mu\text{A}$ typ	
Digital Input Capacitance, $C_{IN}$	3		$\pm 0.1$	$\mu\text{A}$ max pF typ	
<b>DYNAMIC CHARACTERISTICS <sup>1</sup></b>					
Transition Time, $t_{TRANSITION}$	155			ns typ	$R_L = 300 \Omega$ , $C_L = 35 \text{ pF}$
$t_{ON}(\overline{EN})$	200	215	230	ns max	$V_S = 18 \text{ V}$ ; see Figure 33
$t_{OFF}(\overline{EN})$	180			ns typ	$R_L = 300 \Omega$ , $C_L = 35 \text{ pF}$
	215	235	250	ns max	$V_S = 18 \text{ V}$ ; see Figure 35
	150			ns typ	$R_L = 300 \Omega$ , $C_L = 35 \text{ pF}$
Break-Before-Make Time Delay, $t_D$	190	190	190	ns max	$V_S = 18 \text{ V}$ ; see Figure 35
	50			ns typ	$R_L = 300 \Omega$ , $C_L = 35 \text{ pF}$
			25	ns min	$V_{S1} = V_{S2} = 18 \text{ V}$ ; see Figure 34
Charge Injection, $Q_{INJ}$	0.5			pC typ	$V_S = 18 \text{ V}$ , $R_S = 0 \Omega$ , $C_L = 1 \text{ nF}$ ; see Figure 36
Off Isolation	−76			dB typ	$R_L = 50 \Omega$ , $C_L = 5 \text{ pF}$ , $f = 1 \text{ MHz}$ ; see Figure 31
Channel-to-Channel Crosstalk	−87			dB typ	$R_L = 50 \Omega$ , $C_L = 5 \text{ pF}$ , $f = 1 \text{ MHz}$ ; see Figure 29
−3 dB Bandwidth	275			MHz typ	$R_L = 50 \Omega$ , $C_L = 5 \text{ pF}$ ; see Figure 32
Insertion Loss	−6.2			dB typ	$R_L = 50 \Omega$ , $C_L = 5 \text{ pF}$ , $f = 1 \text{ MHz}$ ; see Figure 32
$C_S$ (Off)	2.8			pF typ	$V_S = 18 \text{ V}$ , $f = 1 \text{ MHz}$
$C_D$ (Off)	9			pF typ	$V_S = 18 \text{ V}$ , $f = 1 \text{ MHz}$
$C_D$ (On), $C_S$ (On)	13			pF typ	$V_S = 18 \text{ V}$ , $f = 1 \text{ MHz}$
<b>POWER REQUIREMENTS</b>					
$I_{DD}$	80			$\mu\text{A}$ typ	$V_{DD} = 39.6 \text{ V}$
	100		130	$\mu\text{A}$ max	Digital inputs = 0 V or $V_{DD}$
$V_{DD}$			9/40	V min/V max	$GND = 0 \text{ V}$ , $V_{SS} = 0 \text{ V}$

<sup>1</sup> Guaranteed by design; not subject to production test.

## CONTINUOUS CURRENT PER CHANNEL, $S_x$ OR $D_x$

Table 5. ADG5233

Parameter	25°C	85°C	125°C	Unit
<b>CONTINUOUS CURRENT, <math>S_x</math> OR <math>D_x</math></b>				
$V_{DD} = +15 \text{ V}$ , $V_{SS} = -15 \text{ V}$				
TSSOP ( $\theta_{JA} = 112.6^\circ\text{C/W}$ )	24	16	11	mA maximum
LFCSP ( $\theta_{JA} = 30.4^\circ\text{C/W}$ )	42	26.5	15	mA maximum
$V_{DD} = +20 \text{ V}$ , $V_{SS} = -20 \text{ V}$				
TSSOP ( $\theta_{JA} = 112.6^\circ\text{C/W}$ )	26	17	11	mA maximum
LFCSP ( $\theta_{JA} = 30.4^\circ\text{C/W}$ )	46	28	15	mA maximum
$V_{DD} = 12 \text{ V}$ , $V_{SS} = 0 \text{ V}$				
TSSOP ( $\theta_{JA} = 112.6^\circ\text{C/W}$ )	17	12	7.7	mA maximum
LFCSP ( $\theta_{JA} = 30.4^\circ\text{C/W}$ )	24	17	11	mA maximum
$V_{DD} = 36 \text{ V}$ , $V_{SS} = 0 \text{ V}$				
TSSOP ( $\theta_{JA} = 112.6^\circ\text{C/W}$ )	25	17	11	mA maximum
LFCSP ( $\theta_{JA} = 30.4^\circ\text{C/W}$ )	45	28	15	mA maximum

Table 6. ADG5234

Parameter	25°C	85°C	125°C	Unit
CONTINUOUS CURRENT, Sx OR Dx				
$V_{DD} = +15\text{ V}, V_{SS} = -15\text{ V}$				
TSSOP ( $\theta_{JA} = 112.6^\circ\text{C/W}$ )	21	15	10	mA maximum
LFCSP ( $\theta_{JA} = 30.4^\circ\text{C/W}$ )	38	24	14	mA maximum
$V_{DD} = +20\text{ V}, V_{SS} = -20\text{ V}$				
TSSOP ( $\theta_{JA} = 112.6^\circ\text{C/W}$ )	22	15	10	mA maximum
LFCSP ( $\theta_{JA} = 30.4^\circ\text{C/W}$ )	41	26	15	mA maximum
$V_{DD} = 12\text{ V}, V_{SS} = 0\text{ V}$				
TSSOP ( $\theta_{JA} = 112.6^\circ\text{C/W}$ )	15	11	7	mA maximum
LFCSP ( $\theta_{JA} = 30.4^\circ\text{C/W}$ )	22	16	11	mA maximum
$V_{DD} = 36\text{ V}, V_{SS} = 0\text{ V}$				
TSSOP ( $\theta_{JA} = 112.6^\circ\text{C/W}$ )	22	15	10	mA maximum
LFCSP ( $\theta_{JA} = 30.4^\circ\text{C/W}$ )	40	26	15	mA maximum

## ABSOLUTE MAXIMUM RATINGS

$T_A = 25^\circ\text{C}$ , unless otherwise noted.

Table 7.

Parameter	Rating
$V_{DD}$ to $V_{SS}$	48 V
$V_{DD}$ to GND	-0.3 V to +48 V
$V_{SS}$ to GND	+0.3 V to -48 V
Analog Inputs <sup>1</sup>	$V_{SS} - 0.3\text{ V}$ to $V_{DD} + 0.3\text{ V}$ or 30 mA, whichever occurs first
Digital Inputs <sup>1</sup>	$V_{SS} - 0.3\text{ V}$ to $V_{DD} + 0.3\text{ V}$ or 30 mA, whichever occurs first
Peak Current, Sx or Dx Pins ADG5233 ADG5234	76 mA (pulsed at 1 ms, 10% duty cycle maximum) 67 mA (pulsed at 1 ms, 10% duty cycle maximum)
Continuous Current, Sx or Dx <sup>2</sup>	Data + 15%
Temperature Range	
Operating	-40°C to +125°C
Storage	-65°C to +150°C
Junction Temperature	150°C
Thermal Impedance, $\theta_{JA}$	
16-Lead TSSOP (4-Layer Board)	112.6°C/W
20-Lead TSSOP (4-Layer Board)	143°C/W
16-Lead LFCSP (4-Layer Board)	30.4°C/W
20-Lead LFCSP (4-Layer Board)	30.4°C/W
Reflow Soldering Peak Temperature, Pb Free	260(+0/-5)°C
Human Body Model (HBM) ESD	
Input/Output Port to Supplies	8 kV
Input/Output Port to Input/Output Port	2 kV
All Other Pins	8 kV

<sup>1</sup> Overvoltages at the INx, Sx, and Dx pins are clamped by internal diodes. Limit current to the maximum ratings given.

<sup>2</sup> See Table 5 and Table 6.

Stresses at or above those listed under Absolute Maximum Ratings may cause permanent damage to the product. This is a stress rating only; functional operation of the product at these or any other conditions above those indicated in the operational section of this specification is not implied. Operation beyond the maximum operating conditions for extended periods may affect product reliability.

Only one absolute maximum rating can be applied at any one time.

### ESD CAUTION



#### ESD (electrostatic discharge) sensitive device.

Charged devices and circuit boards can discharge without detection. Although this product features patented or proprietary protection circuitry, damage may occur on devices subjected to high energy ESD. Therefore, proper ESD precautions should be taken to avoid performance degradation or loss of functionality.

PIN CONFIGURATIONS AND FUNCTION DESCRIPTIONS

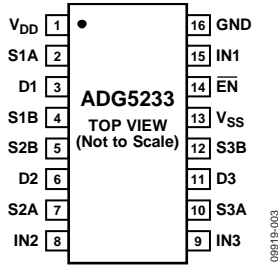
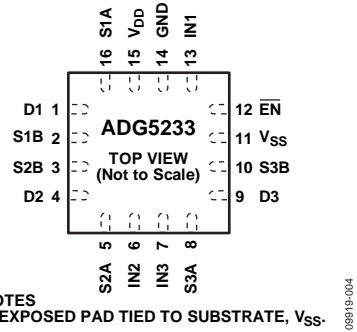

Figure 3. ADG5233 TSSOP Pin Configuration



NOTES  
1. EXPOSED PAD TIED TO SUBSTRATE, VSS.

Figure 4. ADG5233 LFCSP\_WQ Pin Configuration

Table 8. ADG5233 Pin Function Descriptions

Pin No.		Mnemonic	Description
TSSOP	LFCSP_WQ		
1	15	V <sub>DD</sub>	Most Positive Power Supply Potential.
2	16	S1A	Source Terminal 1A. This pin can be an input or an output.
3	1	D1	Drain Terminal 1. This pin can be an input or an output.
4	2	S1B	Source Terminal 1B. This pin can be an input or an output.
5	3	S2B	Source Terminal 2B. This pin can be an input or an output.
6	4	D2	Drain Terminal 2. This pin can be an input or an output.
7	5	S2A	Source Terminal 2A. This pin can be an input or an output.
8	6	IN2	Logic Control Input 2.
9	7	IN3	Logic Control Input 3.
10	8	S3A	Source Terminal 3A. This pin can be an input or an output.
11	9	D3	Drain Terminal 3. This pin can be an input or an output.
12	10	S3B	Source Terminal 3B. This pin can be an input or an output.
13	11	V <sub>SS</sub>	Most Negative Power Supply Potential. In single-supply applications, this pin can be connected to ground.
14	12	$\overline{\text{EN}}$	Active Low Digital Input. When high, the device is disabled and all switches are off. When low, IN <sub>x</sub> logic inputs determine the on switches.
15	13	IN1	Logic Control Input 1.
16	14	GND	Ground (0 V) Reference.
	17	EPAD	The exposed pad is connected internally. For increased reliability of the solder joints and maximum thermal capability, it is recommended that the pad be soldered to the substrate, V <sub>SS</sub> .

Table 9. ADG5233 Truth Table

$\overline{\text{EN}}$	IN <sub>x</sub>	S <sub>x</sub> A	S <sub>x</sub> B
1	X <sup>1</sup>	Off	Off
0	0	Off	On
0	1	On	Off

<sup>1</sup> X is don't care.

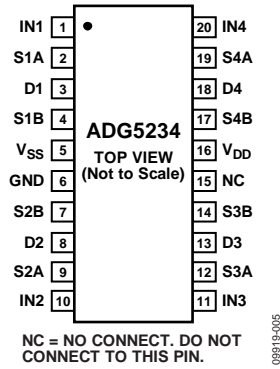
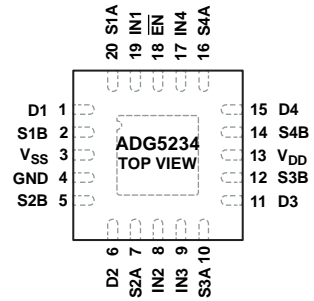

Figure 5. ADG5234 TSSOP Pin Configuration



NOTES  
1. EXPOSED PAD TIED TO SUBSTRATE, V<sub>SS</sub>.

Figure 6. ADG5234 LFCSP\_WQ Pin Configuration

Table 10. ADG5234 Pin Function Descriptions

Pin No.		Mnemonic	Description
TSSOP	LFCSP_WQ		
1	19	IN1	Logic Control Input 1.
2	20	S1A	Source Terminal 1A. This pin can be an input or an output.
3	1	D1	Drain Terminal 1. This pin can be an input or an output.
4	2	S1B	Source Terminal 1B. This pin can be an input or an output.
5	3	V <sub>SS</sub>	Most Negative Power Supply Potential. In single-supply applications, this pin can be connected to ground.
6	4	GND	Ground (0 V) Reference.
7	5	S2B	Source Terminal 2B. This pin can be an input or an output.
8	6	D2	Drain Terminal 2. This pin can be an input or an output.
9	7	S2A	Source Terminal 2A. This pin can be an input or an output.
10	8	IN2	Logic Control Input 2.
11	9	IN3	Logic Control Input 3.
12	10	S3A	Source Terminal 3A. This pin can be an input or an output.
13	11	D3	Drain Terminal 3. This pin can be an input or an output.
14	12	S3B	Source Terminal 3B. This pin can be an input or an output.
15	N/A	NC	No Connect. This pin is open.
16	13	V <sub>DD</sub>	Most Positive Power Supply Potential.
17	14	S4B	Source Terminal 4B. This pin can be an input or an output.
18	15	D4	Drain Terminal 4. This pin can be an input or an output.
19	16	S4A	Source Terminal 4A. This pin can be an input or an output.
20	17	IN4	Logic Control Input 4.
N/A	18	$\overline{\text{EN}}$	Active Low Digital Input. When high, the device is disabled and all switches are off. When low, IN <sub>x</sub> logic inputs determine the on switches.
N/A	21	EP	Exposed Pad. The exposed pad is connected internally. For increased reliability of the solder joints and maximum thermal capability, it is recommended that the pad be soldered to the substrate, V <sub>SS</sub> .

Table 11. ADG5234 Truth Table

IN <sub>x</sub>	S <sub>x</sub> A	S <sub>x</sub> B
0	Off	On
1	On	Off

TYPICAL PERFORMANCE CHARACTERISTICS

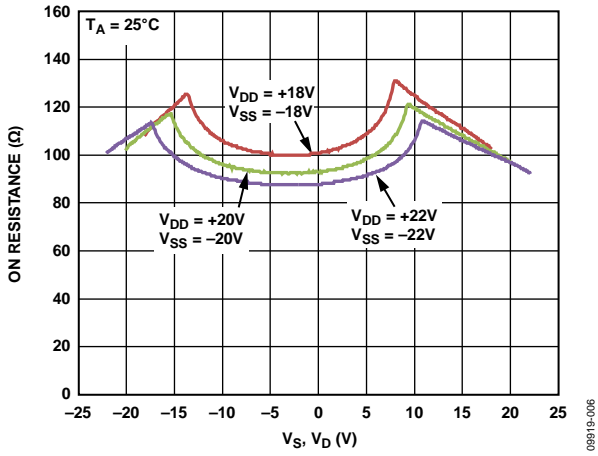

Figure 7. On Resistance as a Function of  $V_S, V_D$  ( $\pm 20$  V Dual Supply)

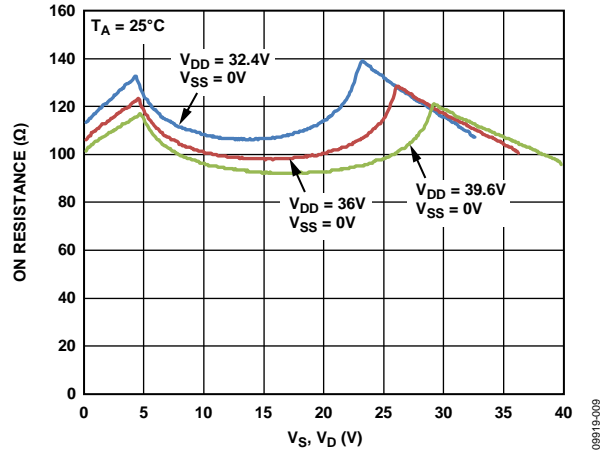

Figure 10. On Resistance as a Function of  $V_S, V_D$  (36 V Single Supply)

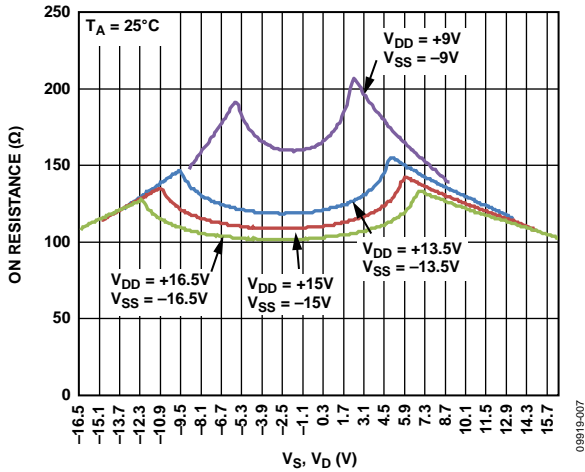

Figure 8. On Resistance as a Function of  $V_S, V_D$  ( $\pm 15$  V Dual Supply)

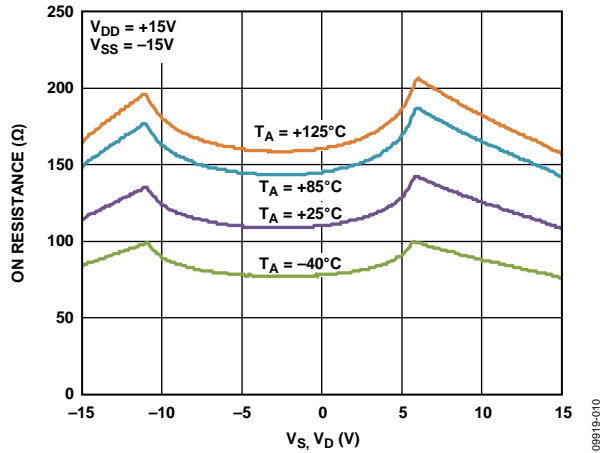

Figure 11. On Resistance as a Function of  $V_S (V_D)$  for Different Temperatures,  $\pm 15$  V Dual Supply

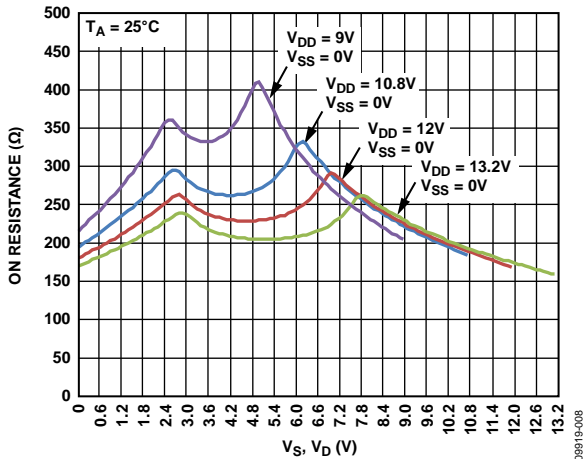

Figure 9. On Resistance as a Function of  $V_S, V_D$  (12 V Single Supply)

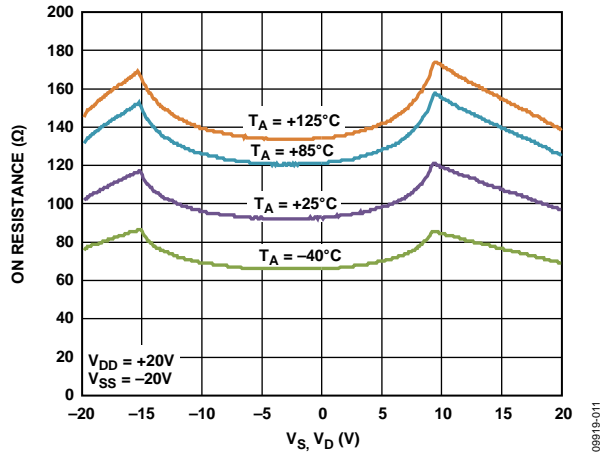

Figure 12. On Resistance as a Function of  $V_S (V_D)$  for Different Temperatures,  $\pm 20$  V Dual Supply

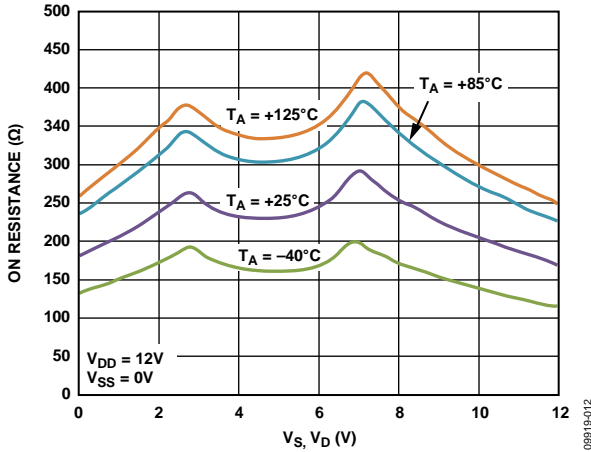

Figure 13. On Resistance as a Function of  $V_S$  ( $V_b$ ) for Different Temperatures, 12 V Single Supply

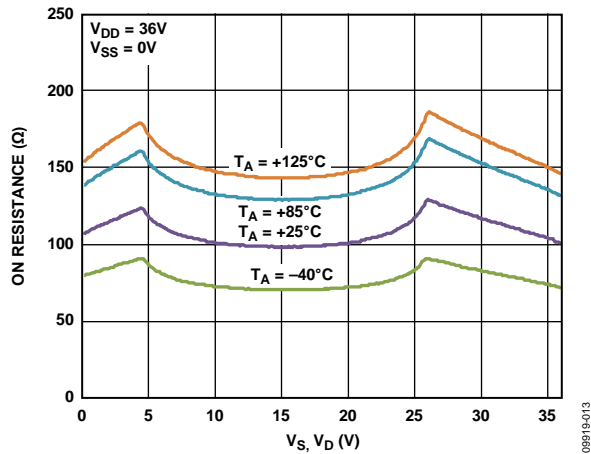

Figure 14. On Resistance as a Function of  $V_S$  ( $V_b$ ) for Different Temperatures, 36 V Single Supply

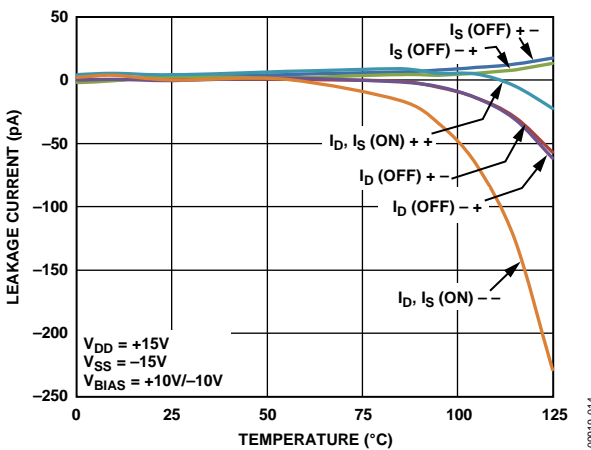

Figure 15. Leakage Currents as a Function of Temperature,  $\pm 15$  V Dual Supply

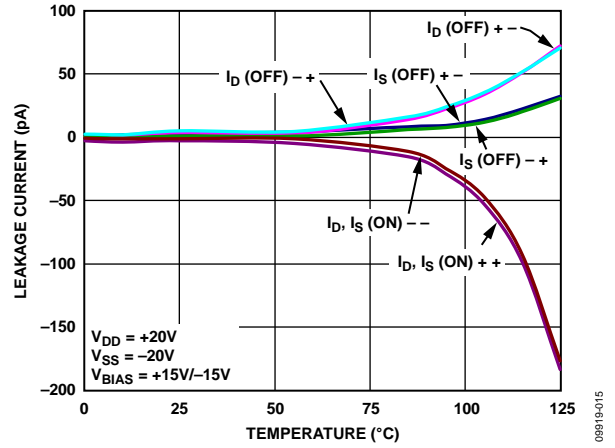

Figure 16. Leakage Currents as a Function of Temperature,  $\pm 20$  V Dual Supply

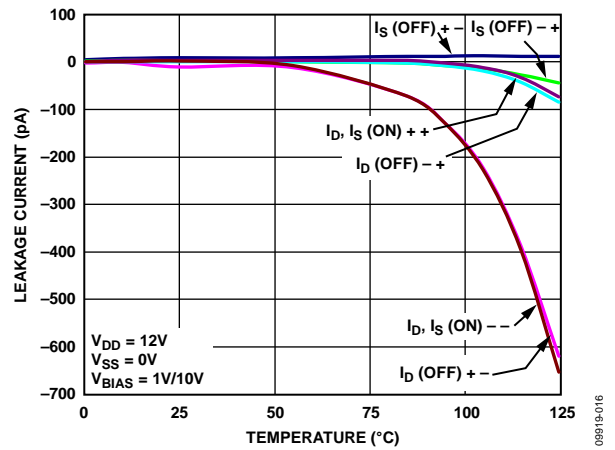

Figure 17. Leakage Currents as a Function of Temperature, 12 V Single Supply

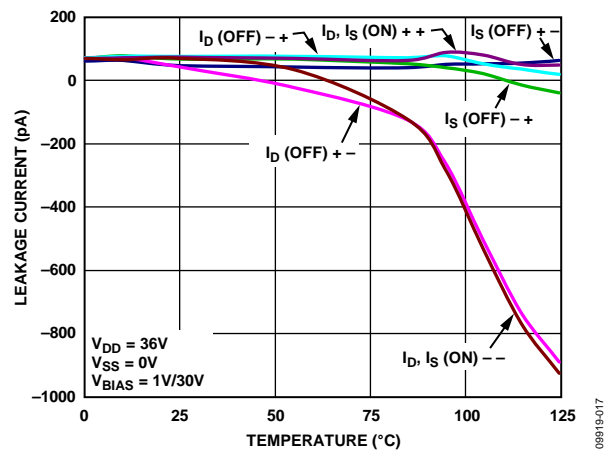

Figure 18. Leakage Currents as a Function of Temperature, 36 V Single Supply

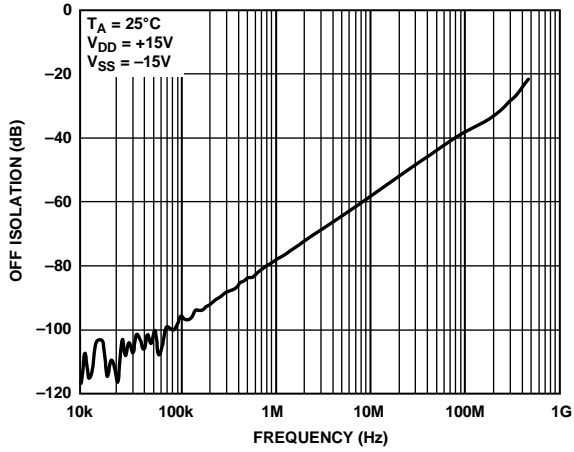

Figure 19. Off Isolation vs. Frequency, ±15 V Dual Supply

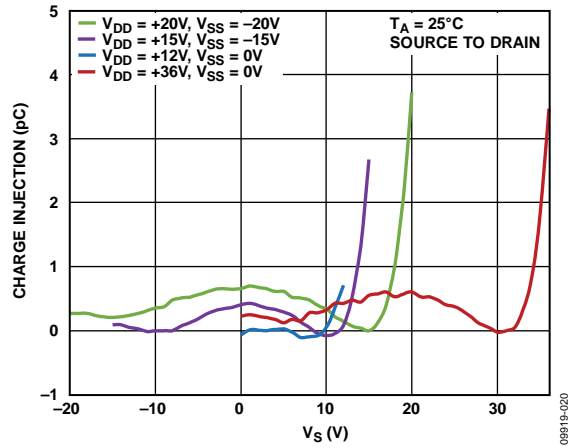

Figure 21. Charge Injection vs. Source Voltage, Source to Drain

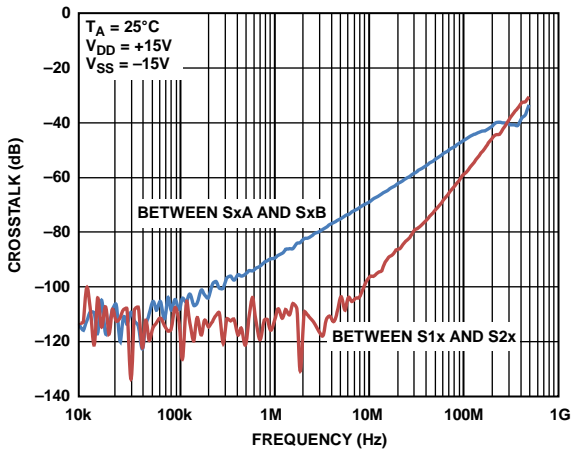

Figure 20. Crosstalk vs. Frequency, ±15 V Dual Supply

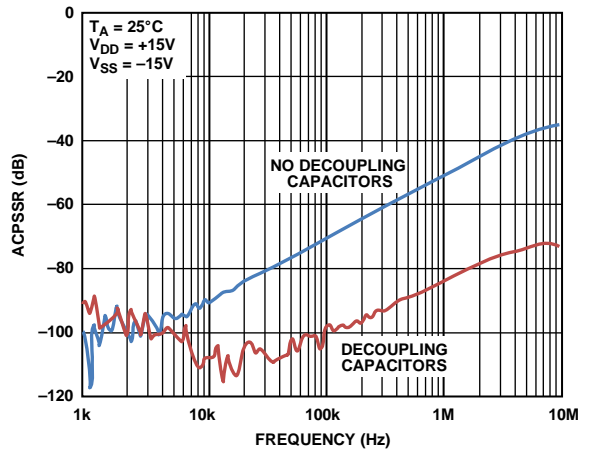

Figure 22. ACPSSR vs. Frequency, ±15 V Dual Supply

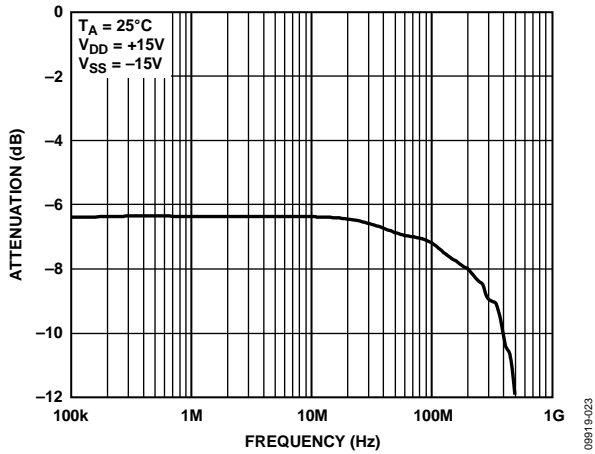

Figure 23. Bandwidth

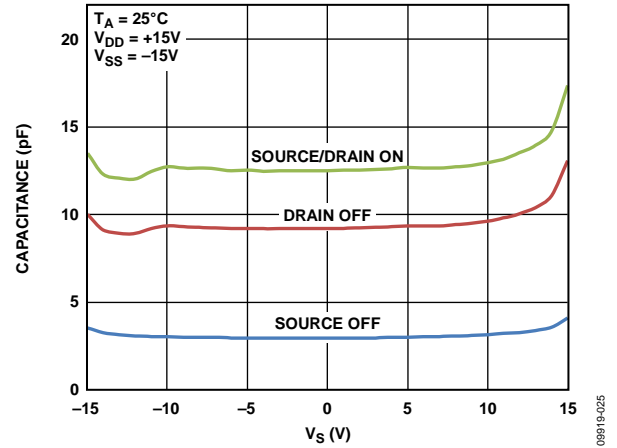

Figure 25. Capacitance vs. Source Voltage,  $\pm 15\text{ V}$  Dual Supply

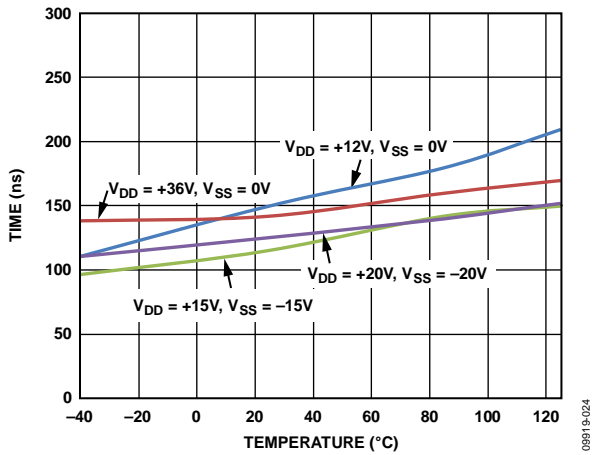

Figure 24.  $t_{\text{TRANSITION}}$  Times vs. Temperature

TEST CIRCUITS

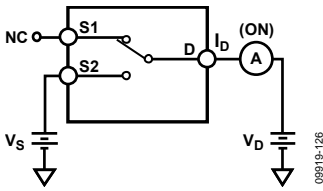

Figure 26. On Leakage

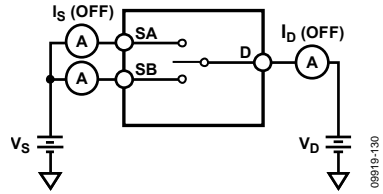

Figure 30. Off Leakage

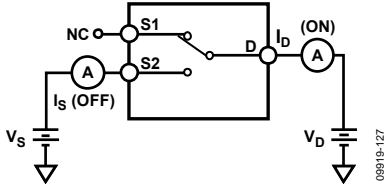
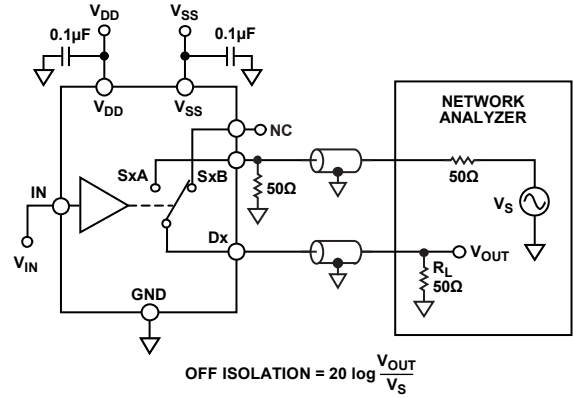

Figure 27. On and Off Leakage On and Off Leakage (ADG5234 TSSOP)



$$\text{OFF ISOLATION} = 20 \log \frac{V_{OUT}}{V_S}$$

Figure 31. Off Isolation

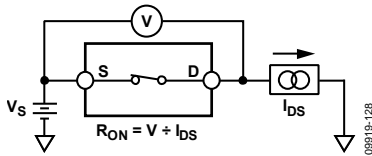
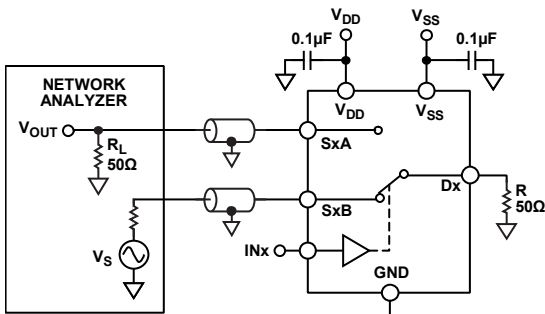
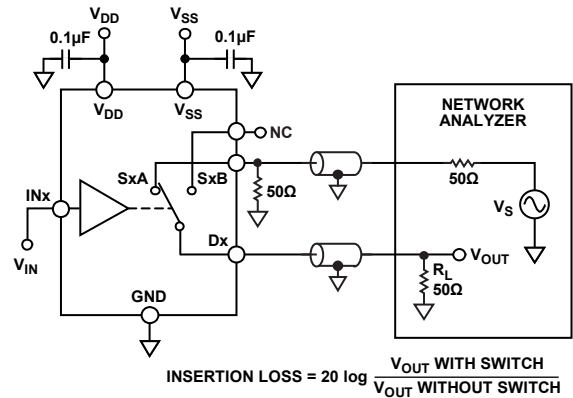

Figure 28. On Resistance



$$\text{CHANNEL-TO-CHANNEL CROSSTALK} = 20 \log \frac{V_{OUT}}{V_S}$$

Figure 29. Channel-to-Channel Crosstalk



$$\text{INSERTION LOSS} = 20 \log \frac{V_{OUT \text{ WITH SWITCH}}}{V_{OUT \text{ WITHOUT SWITCH}}}$$

Figure 32. Bandwidth

09919-029

09919-030

09919-033

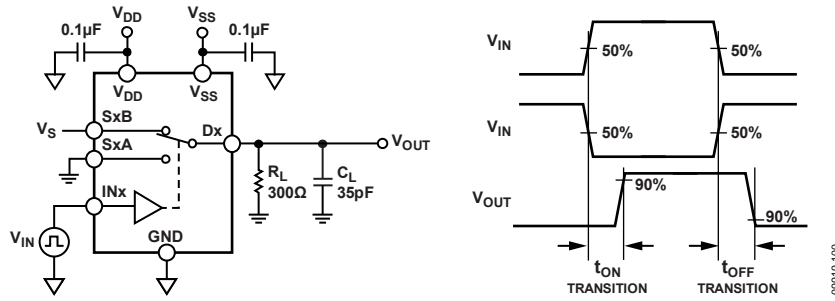

Figure 33. Switching Timing

09919-100

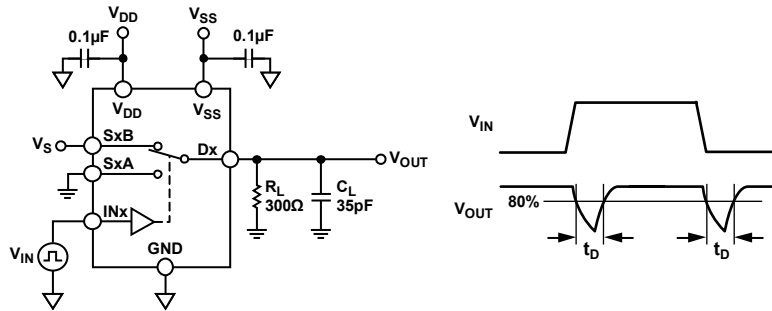

Figure 34. Break-Before-Make Delay,  $t_D$

09919-035

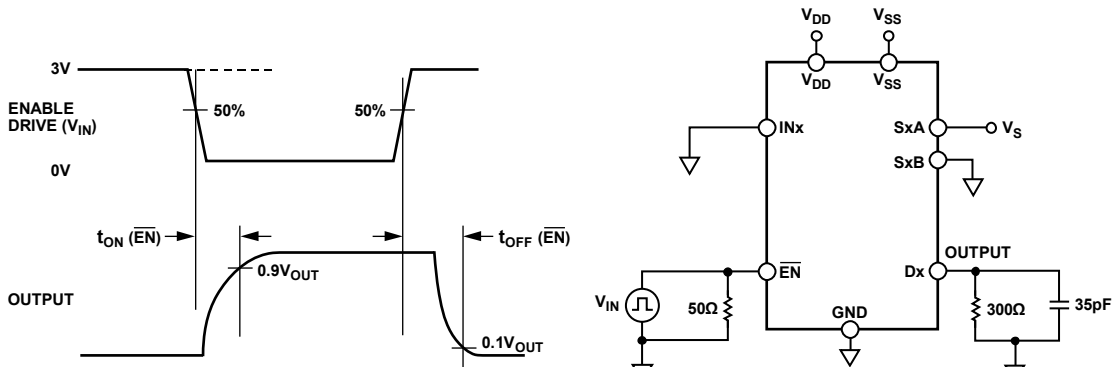

Figure 35. Enable Delay,  $t_{ON}(\overline{EN})$ ,  $t_{OFF}(\overline{EN})$

09919-101

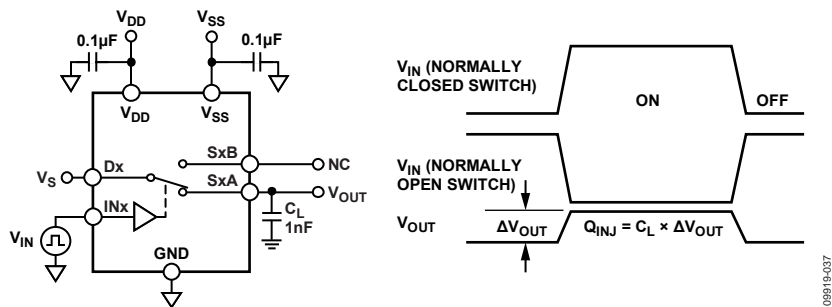

Figure 36. Charge Injection

09919-037

## TERMINOLOGY

### $I_{DD}$

$I_{DD}$  represents the positive supply current.

### $I_{SS}$

$I_{SS}$  represents the negative supply current.

### $V_D, V_S$

$V_D$  and  $V_S$  represent the analog voltage on Terminal Dx and Terminal Sx, respectively.

### $R_{ON}$

$R_{ON}$  is the ohmic resistance between Terminal Dx and Terminal Sx.

### $\Delta R_{ON}$

$\Delta R_{ON}$  represents the difference between the  $R_{ON}$  of any two channels.

### $R_{FLAT(ON)}$

The difference between the maximum and minimum value of on resistance as measured over the specified analog signal range is represented by  $R_{FLAT(ON)}$ .

### $I_S$ (Off)

$I_S$  (Off) is the source leakage current with the switch off.

### $I_D$ (Off)

$I_D$  (Off) is the drain leakage current with the switch off.

### $I_D$ (On), $I_S$ (On)

$I_D$  (On) and  $I_S$  (On) represent the channel leakage currents with the switch on.

### $V_{INL}$

$V_{INL}$  is the maximum input voltage for Logic 0.

### $V_{INH}$

$V_{INH}$  is the minimum input voltage for Logic 1.

### $I_{INL}, I_{INH}$

$I_{INL}$  and  $I_{INH}$  represent the low and high input currents of the digital inputs.

### $C_D$ (Off)

$C_D$  (Off) represents the off switch drain capacitance, which is measured with reference to ground.

### $C_S$ (Off)

$C_S$  (Off) represents the off switch source capacitance, which is measured with reference to ground.

### $C_D$ (On), $C_S$ (On)

$C_D$  (On) and  $C_S$  (On) represent on switch capacitances, which are measured with reference to ground.

### $C_{IN}$

$C_{IN}$  represents digital input capacitance.

### $t_{ON}(\overline{EN})$

$t_{ON}(\overline{EN})$  represents the delay time between the 50% and 90% points of the digital input and switch on condition.

### $t_{OFF}(\overline{EN})$

$t_{OFF}(\overline{EN})$  represents the delay time between the 50% and 90% points of the digital input and switch off condition.

### $t_{TRANSITION}$

Delay time between the 50% and 90% points of the digital inputs and the switch on condition when switching from one address state to another.

### $t_D$

$t_D$  represents the off time measured between the 80% point of both switches when switching from one address state to another.

### Off Isolation

Off isolation is a measure of unwanted signal coupling through an off channel.

### Charge Injection

Charge injection is a measure of the glitch impulse transferred from the digital input to the analog output during switching.

### Crosstalk

Crosstalk is a measure of unwanted signal that is coupled through from one channel to another as a result of parasitic capacitance.

### Bandwidth

Bandwidth is the frequency at which the output is attenuated by 3 dB.

### On Response

On response is the frequency response of the on switch.

### AC Power Supply Rejection Ratio (ACPSRR)

ACPSRR is a measure of the ability of a part to avoid coupling noise and spurious signals that appear on the supply voltage pin to the output of the switch. The dc voltage on the device is modulated by a sine wave of 0.62 V p-p. The ratio of the amplitude of the signal on the output to the amplitude of the modulation is the ACPSRR.

## TRENCH ISOLATION

In the [ADG5233/ADG5234](#), an insulating oxide layer (trench) is placed between the NMOS and the PMOS transistors of each CMOS switch. Parasitic junctions, which occur between the transistors in junction isolated switches, are eliminated, and the result is a completely latch-up proof switch.

In junction isolation, the N and P wells of the PMOS and NMOS transistors form a diode that is reverse-biased under normal operation. However, during overvoltage conditions, this diode can become forward-biased. A silicon controlled rectifier (SCR) type circuit is formed by the two transistors causing a significant amplification of the current that, in turn, leads to latch-up. With trench isolation, this diode is removed, and the result is a latch-up proof switch.

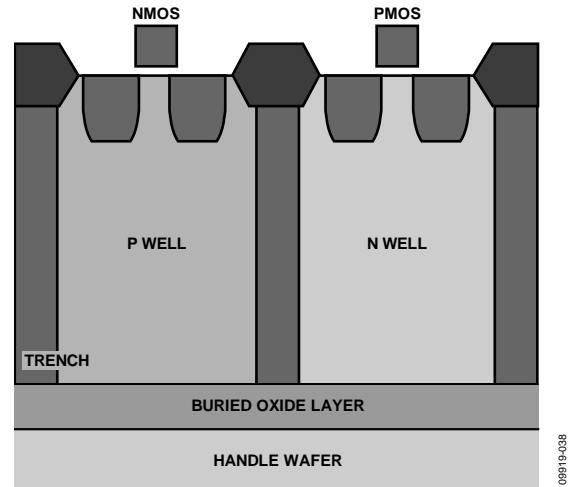

Figure 37. Trench Isolation

## APPLICATIONS INFORMATION

The low capacitance latch-up immune family of switches and multiplexers provide a robust solution for instrumentation, industrial, automotive, aerospace, and other harsh environments that are prone to latch-up, which is an undesirable high current state that can lead to device failure and persists until the power supply is turned off.

The [ADG5233/ADG5234](#) high voltage switches allow single-supply operation from 9 V to 40 V and dual supply operation from  $\pm 9$  V to  $\pm 22$  V.

# OUTLINE DIMENSIONS

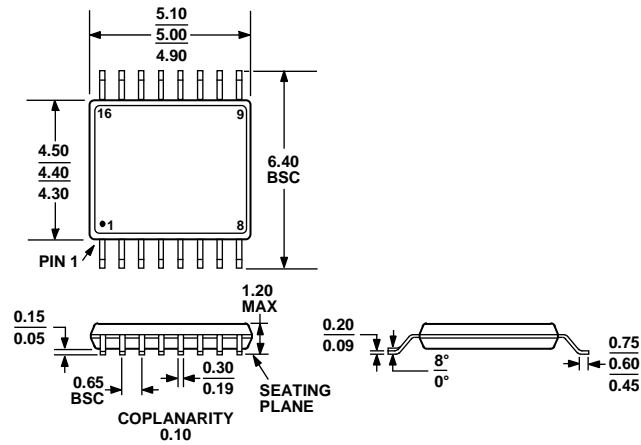

COMPLIANT TO JEDEC STANDARDS MO-153-AB

Figure 38. 16-Lead Thin Shrink Small Outline Package [TSSOP] (RU-16)  
Dimensions shown in millimeters

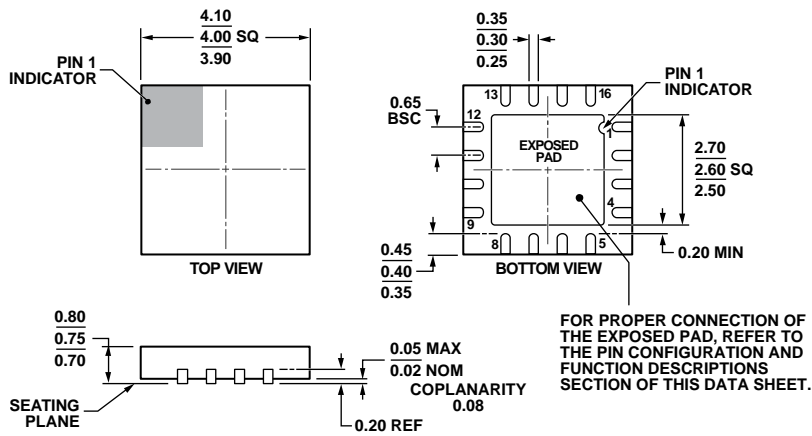

FOR PROPER CONNECTION OF THE EXPOSED PAD, REFER TO THE PIN CONFIGURATION AND FUNCTION DESCRIPTIONS SECTION OF THIS DATA SHEET.

COMPLIANT TO JEDEC STANDARDS MO-220-WGGC.

Figure 39. 16-Lead Lead Frame Chip Scale Package [LFCSP\_WQ] 4 mm x 4 mm Body, Very Very Thin Quad (CP-16-17)  
Dimensions shown in millimeters

08-16-2010-C

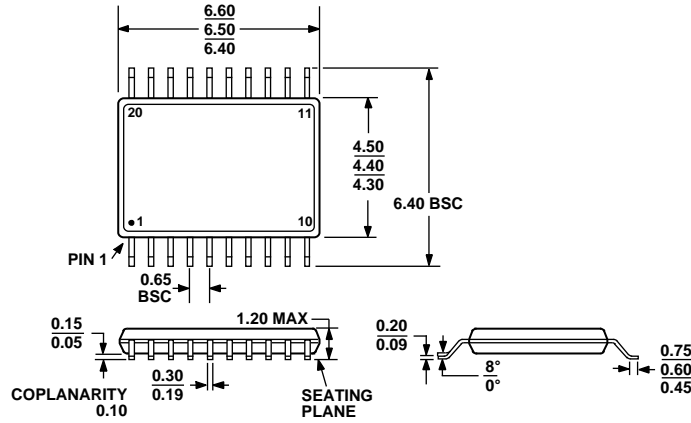

COMPLIANT TO JEDEC STANDARDS MO-153-AC  
 Figure 40. 20-Lead Thin Shrink Small Outline Package [TSSOP] (RU-20)  
 Dimensions shown in millimeters

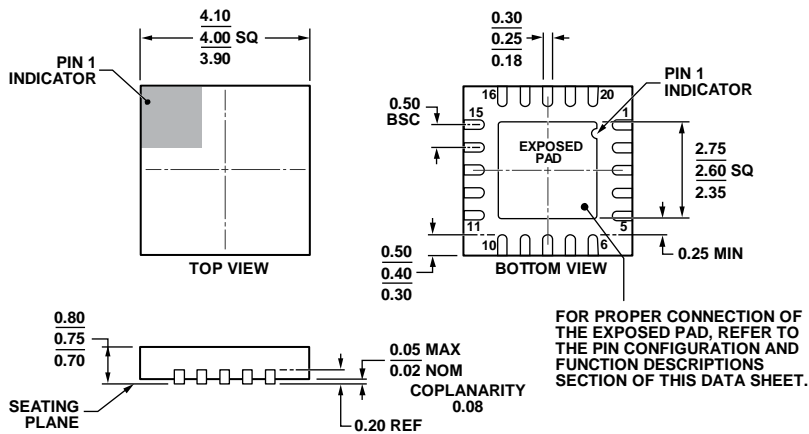

COMPLIANT TO JEDEC STANDARDS MO-220-WGGD.  
 Figure 41. 20-LEAD LEAD FRAME CHIP SCALE PACKAGE [LFCSP\_WQ]  
 4 mm x 4 mm BODY, VERY VERY THIN QUAD (CP-20-8)  
 Dimensions shown in millimeters

**ORDERING GUIDE**

Model <sup>1</sup>	Temperature Range	Description	EN Pin	Package Option
ADG5233BRUZ	-40°C to +125°C	16-Lead Thin Shrink Small Outline Package [TSSOP]	Yes	RU-16
ADG5233BRUZ-RL7	-40°C to +125°C	16-Lead Thin Shrink Small Outline Package [TSSOP]	Yes	RU-16
ADG5233BCPZ-RL7	-40°C to +125°C	16-Lead Lead Frame Chip Scale Package [LFCSP_WQ]	Yes	CP-16-17
ADG5234BRUZ	-40°C to +125°C	20-Lead Thin Shrink Small Outline Package [TSSOP]	No	RU-20
ADG5234BRUZ-RL7	-40°C to +125°C	20-Lead Thin Shrink Small Outline Package [TSSOP]	No	RU-20
ADG5234BCPZ-RL7	-40°C to +125°C	20-Lead Lead Frame Chip Scale Package [LFCSP_WQ]	Yes	CP-20-8

<sup>1</sup> Z = RoHS Compliant Part.

## Looking for pricing, stock, or lifecycle information?

Click below to explore more details on WIN SOURCE:

 [View ADG5234BRUZ-RL7 on WIN SOURCE](#)

 [Analog Devices Inc. Information](#)

## Optimize Your Supply Chain with WIN SOURCE Solutions

-  Global Sourcing Solution
-  Obsolete Management
-  Cost Control Management
-  Shortage Management
-  Alternative Solution
-  Excess Inventory Management