



**THE DATASHEET OF
CY25568SXCT**



Spread Spectrum Clock Generator

Features

- 4 to 32 MHz Input frequency range
- 4 to 128 MHz Output frequency range
- accepts clock, crystal and resonator Inputs
- 1x, 2x and 4x frequency multiplication
- Non-modulated reference frequency output
- Center and down spread modulation
- Low power dissipation
 - 3.3 V = 52 mW-typ at 6 MHz
 - 3.3 V = 60 mW-typ at 12 MHz
 - 3.3 V = 72 mW-typ at 24 MHz
- Power-down mode
- Low cycle-to cycle jitter
 - 8 MHz = 195 ps-typ
 - 16 MHz = 175 ps-typ
 - 32 MHz = 100 ps-typ
- Available in 16-pin (150-mil.) SOIC package

- LCD panels and monitors
- Digital copiers
- PDAs
- Automotive
- CD-ROM, VCD and DVD
- Networking, LAN/WAN
- Scanners
- Modems
- Embedded digital systems

Benefits

- Peak EMI reduction by 8 to 16dB
- Fast time to market
- Cost reduction

Functional Description

For a complete list of related documentation, click [here](#).

Applications

- Printers and MFPs

Logic Block Diagram

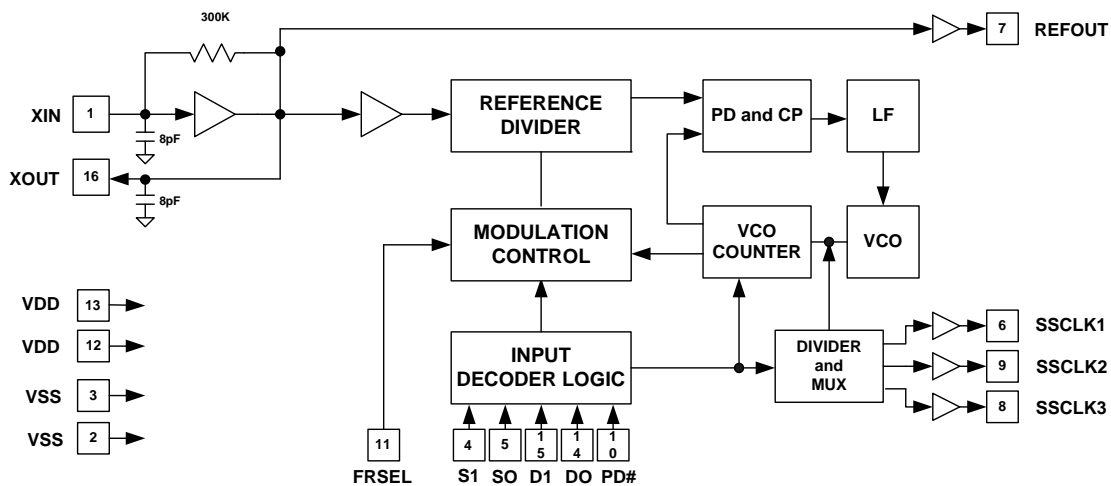

Contents

Pin Configuration	3	SSCG Profiles	10
Pin Definitions	3	Application Schematic	11
Functional Overview	3	Ordering Information	11
Absolute Maximum Ratings	4	Ordering Code Definitions	11
DC Electrical Characteristics	4	Package Diagram	12
Thermal Resistance	4	Acronyms	13
Timing Electrical Characteristics	5	Document Conventions	13
Input Frequency Range and Selection	5	Units of Measure	13
Output Clocks	6	Document History Page	14
REFOUT	6	Sales, Solutions, and Legal Information	15
SSCLK1, 2 and 3	6	Worldwide Sales and Design Support	15
Spread% Selection	7	Products	15
3-Level Digital Inputs	7	PSoC [®] Solutions	15
Power-down (PD#)	8	Cypress Developer Community	15
Modulation Rate	8	Technical Support	15
Characteristic Curves	9		

Pin Configuration

Figure 1. 16-pin SOIC pinout

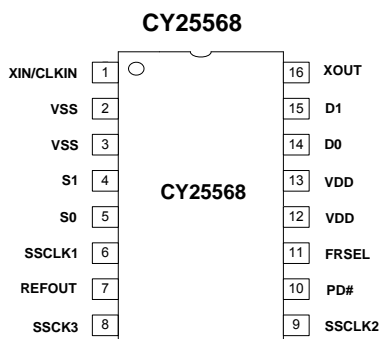

Pin Definitions

Pin	Function	Description
1	Xin/CLK	Clock, crystal or ceramic resonator input pin
2	V _{SS}	Power supply ground.
3	V _{SS}	Power supply ground.
4	S1	Digital Spread% control pin 3-Level input (H-M-L). Default = M.
5	S0	Digital Spread% control pin 3-Level input (H-M-L). Default = M.
6	SSCLK1	Output clock. Refer to Table 2 on page 6 for frequency programmability.
7	REFOUT	Reference clock output. The same frequency as Xin/CLK input.
8	SSCLK3	Output clock. Refer to Table 2 on page 6 for frequency programmability.
9	SSCLK2	Output clock. Refer to Table 2 on page 6 for frequency programmability.
10	PD#	Power-down control Internally pulled to V _{DD} , Default = High.
11	FRSEL	Input frequency range selection digital control input 3-Level input (H-M-L). Default = M.
12	V _{DD}	Positive power supply.
13	V _{DD}	Positive power supply.
14	D0	3-Level (H-M-L) Digital output clock scaling control. Refer to Table 2 on page 6 . Default = M.
15	D1	3-Level (H-M-L) Digital output clock scaling control. Refer to Table 2 on page 6 . Default = M.
16	XOUT	Crystal or ceramic resonator output pin

Functional Overview

The Cypress CY25568 is a spread spectrum clock generator (SSCG) IC used for the purpose of reducing electro magnetic interference (EMI) found in today's high-speed digital electronic systems.

The CY25568 uses a Cypress proprietary phase-locked loop (PLL) and spread spectrum clock (SSC) technology to synthesize and modulate the frequency of the digital clock. By frequency modulating the clock, the measured EMI at the fundamental and harmonic frequencies is greatly reduced.

This reduction in radiated energy can significantly reduce the cost of complying with regulatory agency requirements and improve time to market without degrading system performance.

The CY25568 input frequency range is 4 to 32 MHz and accepts clock, crystal, and ceramic resonator inputs. The output clocks can be programmed to produce 1x, 2x, and 4x multiplication of

the input frequency with spread spectrum. A separate non-modulated reference clock is also provided.

The use of 2x or 4x frequency multiplication eliminates the need for higher order crystals and allows the user to generate up to 128 MHz spread spectrum clock (SSC) by using only first order crystals. This reduces the cost while improving the system clock accuracy, performance and complexity.

The center spread or down spread frequency modulation can be selected by the user based on 4 discrete values of Spread% for each spread mode with the option of a non-spread mode for system test and verification purposes.

The CY25568 is available in a 16-pin SOIC (150-mil.) package with a commercial operating temperature range of 0 to 70 °C. Contact Cypress for availability of -25 to +85 °C industrial temperature range operation. Refer to [CY25811/12/14](#) products for 8-pin SOIC package versions of the CY25568.

Absolute Maximum Ratings

Exceeding maximum ratings ^[1] may shorten the useful life of the device. User guidelines are not tested.

Supply voltage (V_{DD}): +5.5 V

Note: Operation at any Absolute Maximum Rating is not implied.

Input voltage relative to V_{DD} : $V_{DD} + 0.3$ V

Input voltage relative to V_{SS} : $V_{SS} - 0.3$ V

Operating temperature: 0 to 70 °C

storage Temperature: -65 °C to +150 °C

DC Electrical Characteristics

Test Conditions: $V_{DD} = 3.3$ V, $T = 25$ °C, unless otherwise noted

Symbol	Parameter	Min	Typ	Max	Unit	Conditions
VDD	Power supply range	2.90	3.3	3.60	V	
VINH	Input high voltage	$0.85 \times V_{DD}$	V_{DD}	V_{DD}	V	S0,S1,D0,D1 and FRSEL Inputs
VINM	Input middle voltage	$0.40 \times V_{DD}$	$0.50 \times V_{DD}$	$0.60 \times V_{DD}$	V	S0,S1,D0,D1 and FRSEL Inputs
VINL	Input low voltage	0.0	0.0	$0.15 \times V_{DD}$	V	S0,S1,D0,D1 and FRSEL Inputs
VINH1	Input high voltage	2.0	–	–	V	PD# input only
VINL1	Input low voltage	–	–	0.8	V	PD# input only
VOH1	Output high voltage	2.4	–	–	V	IOH = 4 mA, all output clocks
VOH2	Output high voltage	2.0	–	–	V	IOH = 6 mA, all output clocks
VOL1	Output low voltage	–	–	0.4	V	IOL = 4 mA, all output clocks
VOL2	Output low voltage	–	–	1.2	V	IOL = 10 mA, all output clocks
Cin1	Input capacitance	6.0	7.5	9.0	pF	Xin (Pin 1) and Xout (Pin 16)
Cin2	Input capacitance	3.5	4.5	6.0	pF	All digital inputs
IDD1	Power supply current	–	13.0	16.0	mA	Fin = 4 MHz, no load (refer to Figure 4 on page 9)
IDD2	Power supply current	–	28.0	32.0	mA	Fin = 32 MHz, no load (refer to Figure 4 on page 9)
IDD3	Power supply current	–	300	400	µA	PD# = GND

Thermal Resistance

Parameter ^[2]	Description	Test Conditions	16-pin SOIC	Unit
θ_{JA}	Thermal resistance (junction to ambient)	Test conditions follow standard test methods and procedures for measuring thermal impedance, in accordance with EIA/JESD51.	115	°C/W
θ_{JC}	Thermal resistance (junction to case)		45	°C/W

Notes

1. Single Power Supply: The voltage on any input or IO pin cannot exceed the power pin during power-up.
2. These parameters are guaranteed by design and are not tested.

Timing Electrical Characteristics

Test Conditions: $V_{DD} = 3.3\text{ V}$, $T = 25\text{ }^{\circ}\text{C}$, $CL = 15\text{ pF}$. Rise/Fall time at 0.4 and 2.4 V, duty cycle at 1.5 V

Symbol	Parameter	Min	Typ	Max	Unit	Conditions
ICLKFR	Input frequency range	4		32	MHz	Clock, crystal or ceramic resonator input
trise1	Clock rise time	2.4	3.2	4.0	ns	SSCLK1, 2, and 3, all cases when 1x or 2x scaling selected, when 4x if FRSEL = 1 or 0
tfall1	Clock fall time	2.4	3.2	4.0	ns	SSCLK1,2, and 3, all cases when 1x or 2x scaling selected, when 4x if FRSEL = 1 or 0
trise2	Clock rise time	1.2	1.6	2.0	ns	SSCLK2, and 3, only when 4x scaling is selected and FRSEL = M
tfall2	Clock fall time	1.2	1.6	2.0	ns	SSCLK2, and 3, only when 4x scaling is selected and FRSEL = M
trise3	Clock rise time	2.4	3.2	4.0	ns	REFOUT only
tfall3	Clock fall time	2.4	3.2	4.0	ns	REFOUT only
CDCin	Input clock duty cycle	20	50	80	%	XIN/CLK (Pin 1)
CDCout	Output clock duty cycle	45	50	55	%	SSCLK1, 2 and 3
CCJ1	Cycle-to-cycle jitter	-	195	260	ps	Fin = 8 MHz (refer to Figure 4 on page 9)
CCJ2	Cycle-to-cycle jitter	-	170	225	ps	Fin = 16 MHz (refer to Figure 4 on page 9)
CCJ3	Cycle-to-cycle jitter	-	100	150	ps	Fin = 32 MHz (refer to Figure 4A)

Input Frequency Range and Selection

The CY25568 input frequency range is 4 to 32 MHz. This range is divided into 3 segments and controlled by 3-Level FRSEL pin as given in [Table 1](#).

Table 1. Input Frequency Selection

FRSEL	INPUT FREQUENCY RANGE
0	4.0 to 8.0 MHz
1	8.0 to 16.0 MHz
M	16.0 to 32.0 MHz

Output Clocks

The CY25568 provides 4 separate output clocks, REFOUT, SSCLK1, SSCLK2 and SSCLK3, for use in a wide variety of applications. Each clock output is described in detail.

REFOUT

REFOUT is a 3.3 volt CMOS level non-modulated copy of the clock at XIN/CLKIN.

SSCLK1, 2 and 3

SSCLK1, SSCLK2 and SSCLK3 are Spread Spectrum clock outputs used for the purpose of reducing EMI in digital systems. Each clock can drive separate nets with a capacitive load of up to 20 pF.

The frequency function of these clock outputs are selected by using 3-Level D0 and D1 digital inputs and are given in [Table 2](#).

Table 2. Output Clocks Function Selection

D0	D1	REFOUT	SSCLK1	SSCLK2	SSCLK3
0	0	REF	REF	1x	1x
0	M	REF	1x	2x	2x
0	1	REF	REF	2x	2x
M	0	REF	REF	1x	2x
M	M	REF	REF	REF	REF
M	1	REF	REF	2x	4x
1	0	REF	REF	4x	4x
1	M	REF	1x	2x	4x
1	1	REF	1x	2x	4x

REF is the same non-modulated frequency as the input clock.

1x, 2x, or 4x are modulated and multiplied (in the case of 2x and 4x) frequency of the input clock.

Spread% Selection

The CY25568 provides Center-Spread, Down-Spread and No-Spread functions. These functions and the amount of Spread% are selected by using 3-Level S0 and S1 digital inputs and are given in Table 3.

Table 3. Spread% Selection

XIN (MHz)	FRSEL	S1=0 S0=0	S1=0 S0=M	S1=0 S0=1	S1=M S0=0	S1=1 S0=1	S1=1 S0=0	S1=M S0=1	S1=1 S0=M	S1=M S0=M
		CENTER (%)	CENTER (%)	CENTER (%)	CENTER (%)	DOWN (%)	DOWN (%)	DOWN (%)	DOWN (%)	NO SPREAD
4-5	0	+/-1.4	+/-1.2	+/-0.6	+/-0.5	-3.0	-2.2	-1.9	-0.7	0
5-6	0	+/-1.3	+/-1.1	+/-0.5	+/-0.4	-2.7	-1.9	-1.7	-0.6	0
6-7	0	+/-1.2	+/-0.9	+/-0.5	+/-0.4	-2.5	-1.8	-1.5	-0.6	0
7-8	0	+/-1.1	+/-0.9	+/-0.4	+/-0.3	-2.3	-1.7	-1.4	-0.5	0
8-10	1	+/-1.4	+/-1.2	+/-0.6	+/-0.5	-3.0	-2.2	-1.9	-0.7	0
10-12	1	+/-1.3	+/-1.1	+/-0.5	+/-0.4	-2.7	-1.9	-1.7	-0.6	0
12-14	1	+/-1.2	+/-0.9	+/-0.5	+/-0.4	-2.5	-1.8	-1.5	-0.6	0
14-16	1	+/-1.1	+/-0.9	+/-0.4	+/-0.3	-2.3	-1.7	-1.4	-0.5	0
16-20	M	+/-1.4	+/-1.2	+/-0.6	+/-0.5	-3.0	-2.2	-1.9	-0.7	0
20-24	M	+/-1.3	+/-1.1	+/-0.5	+/-0.4	-2.7	-1.9	-1.7	-0.6	0
24-28	M	+/-1.2	+/-0.9	+/-0.5	+/-0.4	-2.5	-1.8	-1.5	-0.6	0
28-32	M	+/-1.1	+/-0.9	+/-0.4	+/-0.3	-2.3	-1.7	-1.4	-0.5	0

3-Level Digital Inputs

Figure 2. 3-Level Logic

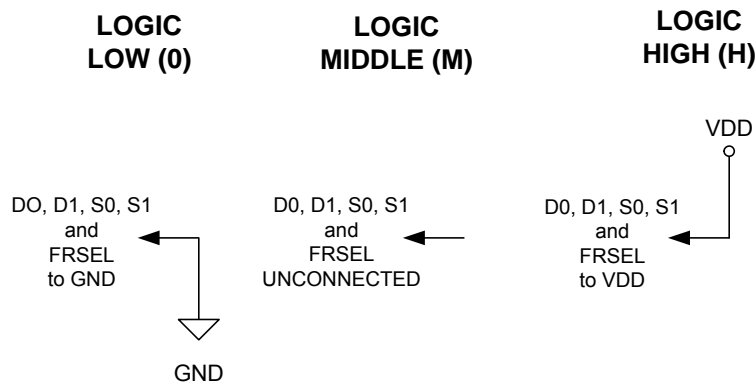

S0, S1, D0, D1, and FRSEL digital inputs of the CY25568 are designed to sense 3 different logic levels designated as High - 1, Low - 0 and Middle - M. With this 3-Level digital input logic, the CY25568 is able to detect 9 different logic states in the case of (S0, S1) and (D0, D1) logic pairs and 3 different logic states in the case of FRSEL.

S0, S1, D0, D1, and FRSEL pins include an on chip 20K (10K /10K) resistor divider. No external application resistors are needed to implement the 3-Level logic levels as shown in the following:

Logic State 0 = 3-Level logic pin connected to GND.

Logic State M = 3-Level logic pin left floating (no connection).

Logic State 1 = 3-Level logic pin connected to VDD.

Figure 2 illustrates how to implement 3-Level Logic.

Power-down (PD#)

CY25568 includes a Power-down (PD#, Pin 10) function. This input uses standard 2-Level CMOS logic and is internally pulled up to VDD (HIGH). Connect this pin to GND if power is to be turned off.

Modulation Rate

Spread Spectrum Clock Generators use frequency modulation (FM) to distribute energy over a specific band of frequencies. The maximum frequency of the clock (fmax) and minimum frequency of the clock (fmin) determine this band of frequencies. The time required to transition from fmin to fmax and back to fmin is the period of the Modulation Rate, Tmod. The Modulation Rate of SSCG clocks are generally referred to in terms of frequency or fmod = 1/Tmod.

The input clock frequency, fin, and the internal divider determine the modulation rate.

In the case of CY25568, the (spread spectrum) modulation rate is given by the following formula: $f_{mod} = f_{in}/DR$

Where; fmod is the modulation rate, fin is the Input Frequency and DR is the divider ratio as given in Table 4. Notice that Input frequency range is set by FRSEL.

Table 4. Modulation Rate

FRSEL	INPUT FREQUENCY RANGE (MHz)	DIVIDER RATIO (DR)
0	4 to 8	128
1	8 to 16	256
M	16 to 32	512

Characteristic Curves

The following curves demonstrate the characteristic behavior of the CY25568 when tested over a number of environmental and application specific parameters. These are typical performance curves and are not meant to replace any parameter specified in tables DC Electrical Characteristics on page 4 and Timing Electrical Characteristics on page 5.

Figure 3. Jitter vs. Input Frequency (No Load)

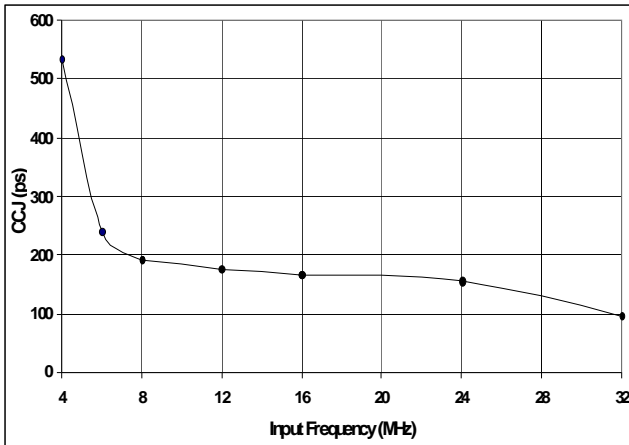

Figure 5. IDD vs. Frequency (FRSEL = 0, 1, M)

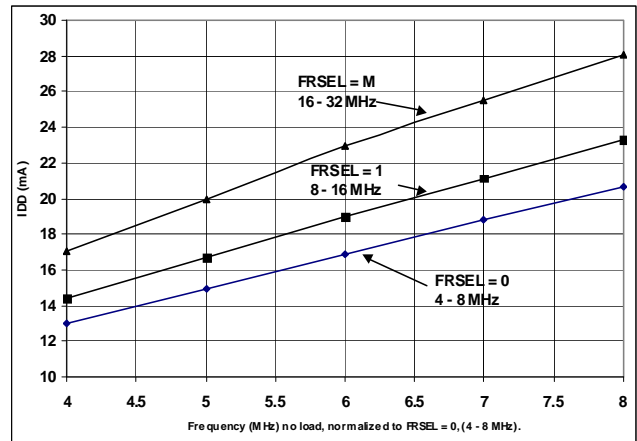

Figure 4. Bandwidth% vs. Temperature

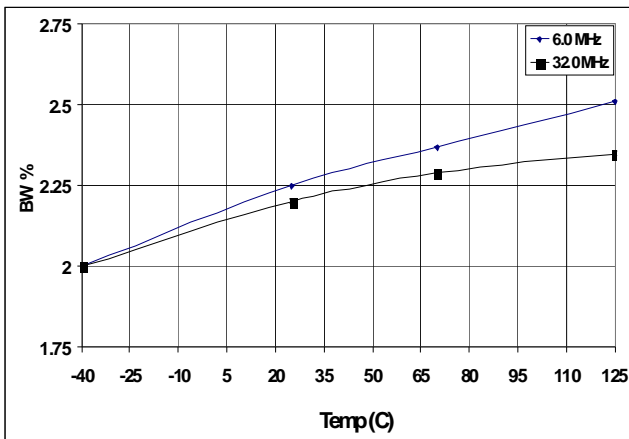
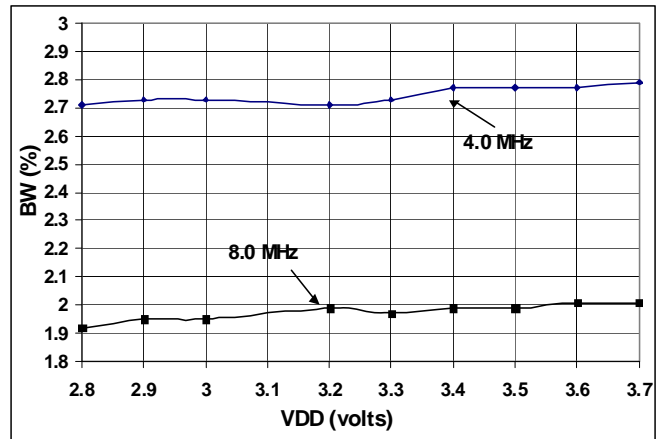

Figure 6. Bandwidth% vs. VDD



SSCG Profiles

The CY25568 uses a non-linear frequency profile as shown in Figure 7. The use of Cypress proprietary “optimized” frequency profile maintains flat energy distribution over the fundamental and higher order harmonics. This results in additional EMI reduction in electronic systems.

Figure 7. Spread Spectrum Profiles (Frequency versus Time)

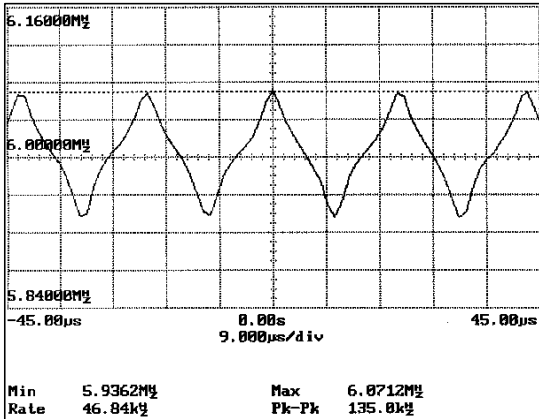

Xin = 6.0 MHz	SSCLK1 = 6.0 MHz
S1, S0 = 0	D1, D0 = 1

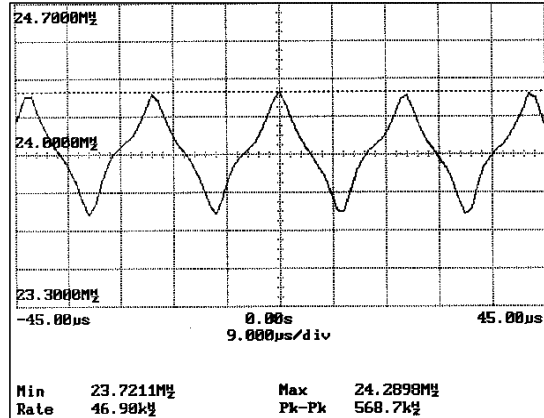

Xin = 24.0 MHz	SSCLK1 = 24.0 MHz
S1, S0 = 0	D1, D0 = 1

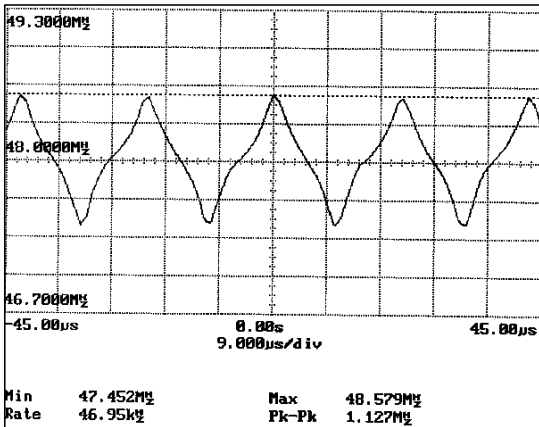

Xin = 12.0 MHz	SSCLK1 = 48.0 MHz
S1, S0 = 0	D1, D0 = 1

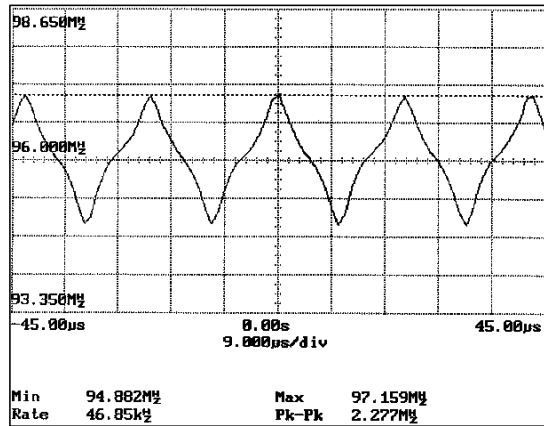

Xin = 24.0 MHz	SSCLK1 = 96.0 MHz
S1, S0 = 0	D1, D0 = 1

Application Schematic

Figure 8. Application Schematic

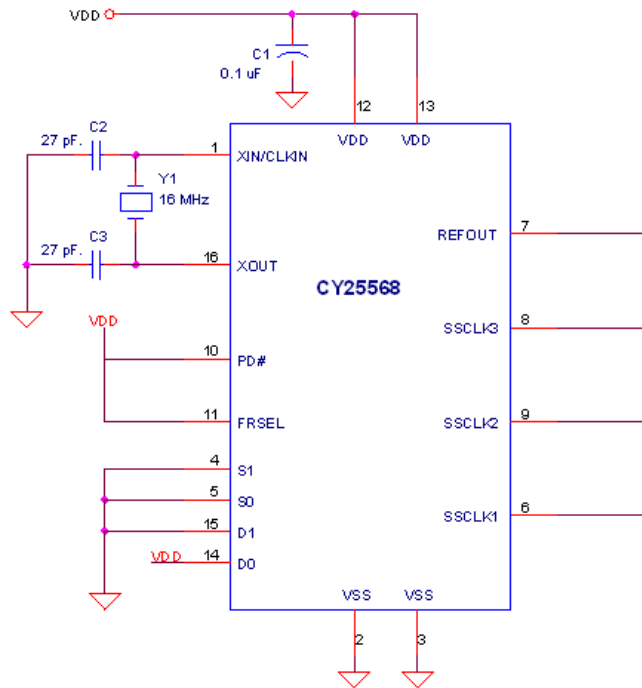

Ordering Information

Part No.	Package	Operating Temperature Range
Pb-free		
CY25568SXC	16-pin SOIC	Commercial, 0 °C to 70 °C
CY25568SXCT	16-pin SOIC – Tape and Reel	Commercial, 0 °C to 70 °C

Ordering Code Definitions

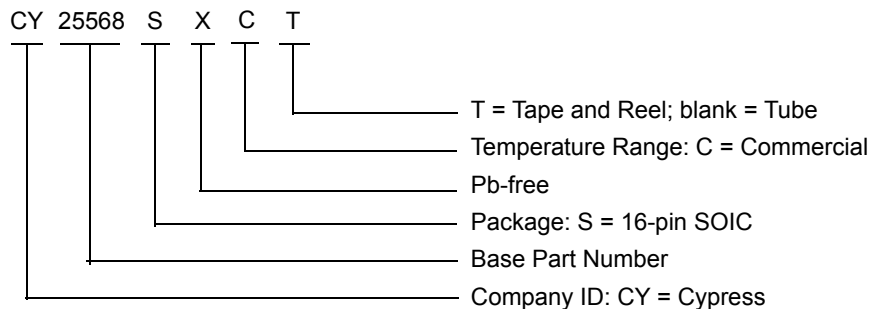

Package Diagram

Figure 9. 16-pin SOIC (150 Mils) S16.15/SZ16.15 Package Outline, 51-85068

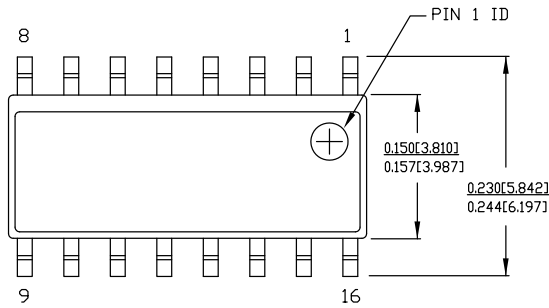

NOTE:

1. DIMENSIONS IN INCHES[MM] **MAX.**
2. REFERENCE JEDEC MS-012
3. PACKAGE WEIGHT : refer to PMDD spec. 001-04308

PART #	
S16.15	STANDARD PKG.
SZ16.15	LEAD FREE PKG.

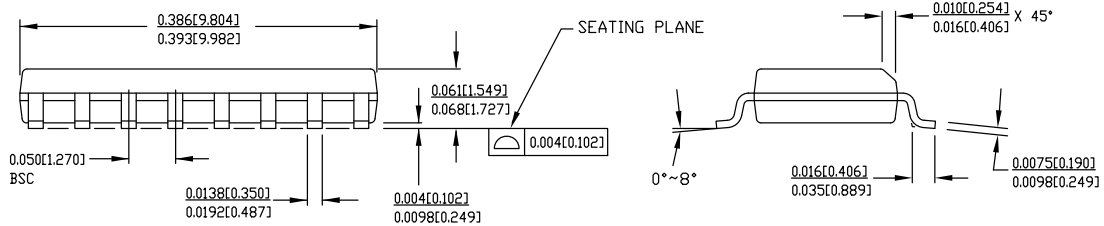

51-85068 *E

Acronyms

Acronym	Description
DVD	digital versatile/video disc
EMI	Electromagnetic Interference
I/O	input/output
LAN	local area network
LCD	liquid crystal display
PLL	phase-locked loop
SOIC	small-outline integrated circuit
SSC	spread spectrum clock
SSCG	spread spectrum clock generator
VCD	video compact disc
WAN	wide area network

Document Conventions

Units of Measure

Symbol	Unit of Measure
%	percent
°C	degree Celsius
dB	decibel
MHz	megahertz
mA	milliampere
mm	millimeter
ms	millisecond
mW	milliwatt
ns	nanosecond
Ω	ohm
pF	picofarad
ps	picosecond
V	volt
W	watt

Document History Page

Document Title: CY25568, Spread Spectrum Clock Generator Document Number: 38-07111				
Rev.	ECN	Orig. of Change	Submission Date	Description of Change
**	107515	NDP	06/14/2001	Convert from IMI to Cypress.
*A	108182	NDP	07/03/2001	Updated Absolute Maximum Ratings : Removed "Junction Temperature (10-sec. soldering)".
*B	122682	RBI	12/21/2002	Updated Absolute Maximum Ratings : Added Note 1 and referred the same note in maximum ratings.
*C	2658020	KVM / PYRS	02/16/2009	Updated Ordering Information : Updated part numbers. Updated Package Diagram : Deleted the table "16 Pin SOIC Outline Dimensions (150 mil)". Updated to new template.
*D	3319217	BASH	07/08/2011	Added Ordering Code Definitions under Ordering Information . Updated Package Diagram . Added Acronyms and Units of Measure . Updated to new template.
*E	4468746	TAVA	08/07/2014	Updated Package Diagram : spec 51-85068 – Changed revision from *C to *E. Updated to new template. Completing Sunset Review.
*F	4586478	TAVA	12/03/2014	Updated Functional Description : Added "For a complete list of related documentation, click here ." at the end.
*G	5281153	PSR	05/23/2016	Added Thermal Resistance . Updated to new template. Completing Sunset Review.
*H	5981734	AESATP12	12/01/2017	Updated logo and copyright.

Sales, Solutions, and Legal Information

Worldwide Sales and Design Support

Cypress maintains a worldwide network of offices, solution centers, manufacturer's representatives, and distributors. To find the office closest to you, visit us at [Cypress Locations](#).

Products

ARM® Cortex® Microcontrollers	cypress.com/arm
Automotive	cypress.com/automotive
Clocks & Buffers	cypress.com/clocks
Interface	cypress.com/interface
Internet of Things	cypress.com/iot
Memory	cypress.com/memory
Microcontrollers	cypress.com/mcu
PSoC	cypress.com/psoc
Power Management ICs	cypress.com/pmic
Touch Sensing	cypress.com/touch
USB Controllers	cypress.com/usb
Wireless Connectivity	cypress.com/wireless

PSoC® Solutions

[PSoC 1](#) | [PSoC 3](#) | [PSoC 4](#) | [PSoC 5LP](#) | [PSoC 6](#)

Cypress Developer Community

[Forums](#) | [WICED IOT Forums](#) | [Projects](#) | [Video](#) | [Blogs](#) | [Training](#) | [Components](#)

Technical Support

cypress.com/support



© Cypress Semiconductor Corporation, 2001-2017. This document is the property of Cypress Semiconductor Corporation and its subsidiaries, including Spansion LLC ("Cypress"). This document, including any software or firmware included or referenced in this document ("Software"), is owned by Cypress under the intellectual property laws and treaties of the United States and other countries worldwide. Cypress reserves all rights under such laws and treaties and does not, except as specifically stated in this paragraph, grant any license under its patents, copyrights, trademarks, or other intellectual property rights. If the Software is not accompanied by a license agreement and you do not otherwise have a written agreement with Cypress governing the use of the Software, then Cypress hereby grants you a personal, non-exclusive, nontransferable license (without the right to sublicense) (1) under its copyright rights in the Software (a) for Software provided in source code form, to modify and reproduce the Software solely for use with Cypress hardware products, only internally within your organization, and (b) to distribute the Software in binary code form externally to end users (either directly or indirectly through resellers and distributors), solely for use on Cypress hardware product units, and (2) under those claims of Cypress's patents that are infringed by the Software (as provided by Cypress, unmodified) to make, use, distribute, and import the Software solely for use with Cypress hardware products. Any other use, reproduction, modification, translation, or compilation of the Software is prohibited.

TO THE EXTENT PERMITTED BY APPLICABLE LAW, CYPRESS MAKES NO WARRANTY OF ANY KIND, EXPRESS OR IMPLIED, WITH REGARD TO THIS DOCUMENT OR ANY SOFTWARE OR ACCOMPANYING HARDWARE, INCLUDING, BUT NOT LIMITED TO, THE IMPLIED WARRANTIES OF MERCHANTABILITY AND FITNESS FOR A PARTICULAR PURPOSE. To the extent permitted by applicable law, Cypress reserves the right to make changes to this document without further notice. Cypress does not assume any liability arising out of the application or use of any product or circuit described in this document. Any information provided in this document, including any sample design information or programming code, is provided only for reference purposes. It is the responsibility of the user of this document to properly design, program, and test the functionality and safety of any application made of this information and any resulting product. Cypress products are not designed, intended, or authorized for use as critical components in systems designed or intended for the operation of weapons, weapons systems, nuclear installations, life-support devices or systems, other medical devices or systems (including resuscitation equipment and surgical implants), pollution control or hazardous substances management, or other uses where the failure of the device or system could cause personal injury, death, or property damage ("Unintended Uses"). A critical component is any component of a device or system whose failure to perform can be reasonably expected to cause the failure of the device or system, or to affect its safety or effectiveness. Cypress is not liable, in whole or in part, and you shall and hereby do release Cypress from any claim, damage, or other liability arising from or related to all Unintended Uses of Cypress products. You shall indemnify and hold Cypress harmless from and against all claims, costs, damages, and other liabilities, including claims for personal injury or death, arising from or related to any Unintended Uses of Cypress products.

Cypress, the Cypress logo, Spansion, the Spansion logo, and combinations thereof, WICED, PSoC, CapSense, EZ-USB, F-RAM, and Traveo are trademarks or registered trademarks of Cypress in the United States and other countries. For a more complete list of Cypress trademarks, visit cypress.com. Other names and brands may be claimed as property of their respective owners.

Looking for pricing, stock, or lifecycle information?

Click below to explore more details on WIN SOURCE:

-  [View CY25568SXCT on WIN SOURCE](#)
-  [Cypress Semiconductor Corp](#) Information

Optimize Your Supply Chain with WIN SOURCE Solutions

-  Global Sourcing Solution
-  Obsolete Management
-  Cost Control Management
-  Shortage Management
-  Alternative Solution
-  Excess Inventory Management