

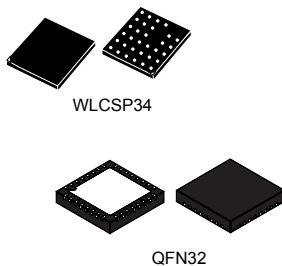

THE DATASHEET OF BLUENRG-MSQTR



Upgradable Bluetooth® low energy network processor



Features

- Bluetooth specification v4.2 compliant master and slave single-mode Bluetooth low energy network processor
- Embedded Bluetooth low energy protocol stack: GAP, GATT, SM, L2CAP, LL, RF-PHY
- Bluetooth low energy profiles provided separately
- Operating supply voltage: from 1.7 to 3.6 V
- 8.2 mA maximum TX current (@0 dBm, 3.0 V)
- Down to 1.7 μ A current consumption with active BLE stack
- Integrated linear regulator and DC-DC step-down converter
- Up to +8 dBm available output power (at antenna connector)
- Excellent RF link budget (up to 96 dB)
- Accurate RSSI to allow power control
- Proprietary application controller interface (ACI), SPI based, allows interfacing with an external host application microcontroller
- Full link controller and host security
- High performance, ultra-low power Cortex-M0 32-bit based architecture core
- Upgradable BLE stack (stored in embedded Flash memory, via SPI)
- AES security co-processor
- Low power modes
- 16 or 32 MHz crystal oscillator
- 12 MHz ring oscillator
- 32 kHz crystal oscillator
- 32 kHz ring oscillator
- Battery voltage monitor
- Compliant with the following radio frequency regulations: ETSI EN 300 328, EN 300 440, FCC CFR47 Part 15, ARIB STD-T66
- Available in QFN32 (5x5 mm) and WLCSP34 (2.66x2.56 mm) packages
- Operating temperature range: -40 °C to 85 °C

Product summary	
Order code	BLUENRG-MSQTR
Package	QFN32 (5x5 mm)
Packing	Tape and reel
Order code	BLUENRG-MSCSP
Package	WLCSP34 (2.66x2.56 mm)
Packing	Tape and reel

Applications

- Watches
- Fitness, wellness and sports
- Consumer medical
- Security/proximity
- Remote control
- Home and industrial automation
- Assisted living
- Mobile phone peripherals
- PC peripherals

1 Description

The [BlueNRG-MS](#) is a very low power Bluetooth low energy (BLE) single-mode network processor, compliant with Bluetooth specification v4.2. The [BlueNRG-MS](#) supports multiple roles simultaneously and can act at the same time as Bluetooth smart sensor and hub device.

The Bluetooth Low Energy stack runs on the embedded ARM Cortex-M0 core. The stack is stored on the on-chip non-volatile Flash memory and can be easily upgraded via SPI.

The device comes pre-programmed with a production-ready stack image(its version could change at any time without notice). A different or more up-to-date stack image can be downloaded from the ST website and programmed on the device through the ST provided software tools.

The [BlueNRG-MS](#) allows applications to meet the tight advisable peak current requirements imposed by standard coin cell batteries.

The maximum peak current is only 10 mA at 1 dBm output power. Ultra low-power sleep modes and very short transition times between operating modes allow very low average current consumption, resulting in longer battery life.

The [BlueNRG-MS](#) offers the option of interfacing with external microcontrollers via SPI transport layer.

2 General description

The BlueNRG-MS is a single-mode Bluetooth low energy master/slave network processor, compliant with the Bluetooth specification v4.2.

It integrates a 2.4 GHz RF transceiver and a powerful Cortex-M0 microcontroller, on which a complete power-optimized stack for Bluetooth single mode protocol runs, providing:

- Master, slave role support
- GAP: central, peripheral, observer or broadcaster roles
- ATT/GATT: client and server
- SM: privacy, authentication and authorization
- L2CAP
- Link Layer: AES-128 encryption and decryption

An on-chip non-volatile Flash memory allows on-field Bluetooth low energy stack upgrade.

In addition, according the Bluetooth specification v4.2 the BlueNRG-MS can support the following features through firmware updates:

- Multiple roles simultaneously support
- Support simultaneous advertising and scanning
- Support being slave of up to two masters simultaneously
- Privacy V1.1
- Low duty cycle directed advertising

The device allows applications to meet of the tight advisable peak current requirements imposed with the use of standard coin cell batteries. If the high efficiency embedded DC-DC step-down converter is used, the maximum input current is only 15 mA at the highest output power (+8 dBm). Even if the DC-DC converter is not used, the maximum input current is only 29 mA at the highest output power, still preserving battery life.

Ultra low-power sleep modes and very short transition time between operating modes result in very low average current consumption during real operating conditions, providing very long battery life.

Two different external matching networks are suggested: standard mode (TX output power up to +5 dBm) and high power mode (TX output power up to +8 dBm).

The external host application processor, where the application resides, is interfaced with the BlueNRG-MS through an application controller interface protocol which is based on a standard SPI interface.

Figure 1. BlueNRG-MS application block diagram

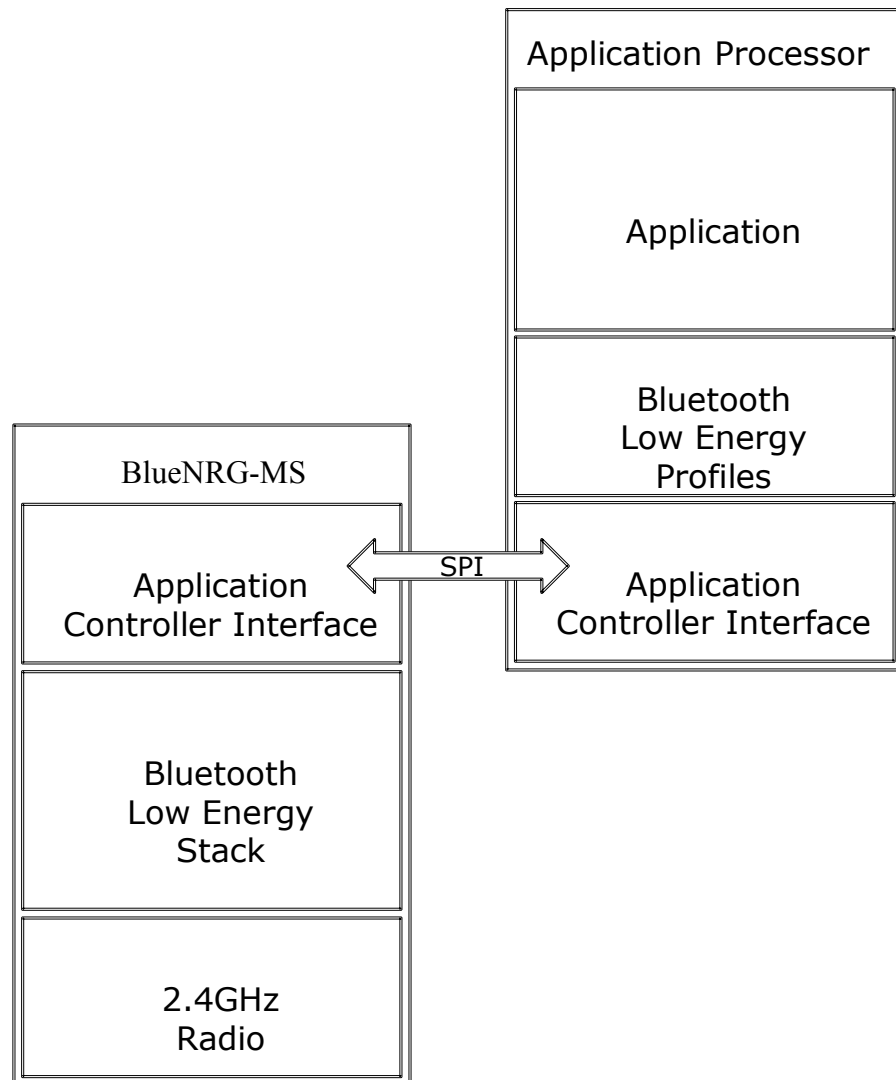

GAMS20150615EC-0957

3 Pin description

The BlueNRG-MS pinout is shown in Figure 2. BlueNRG-MS pinout top view (QFN32), Figure 3. BlueNRG-MS pinout top view (WLCSP34) and Figure 4. BlueNRG-MS pinout bottom view (WLCSP34). In Table 1. Pinout description a short description of the pins is provided.

Figure 2. BlueNRG-MS pinout top view (QFN32)

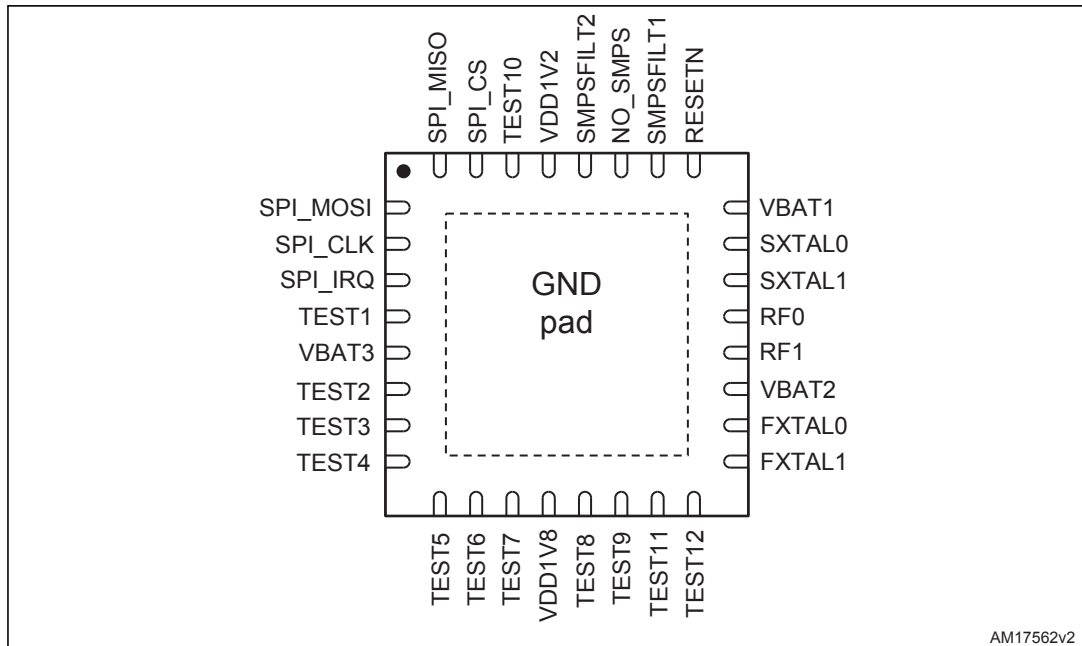
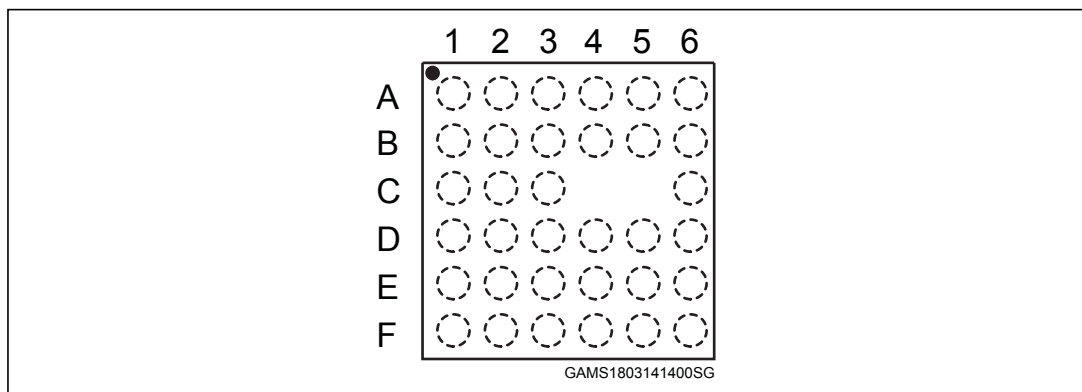
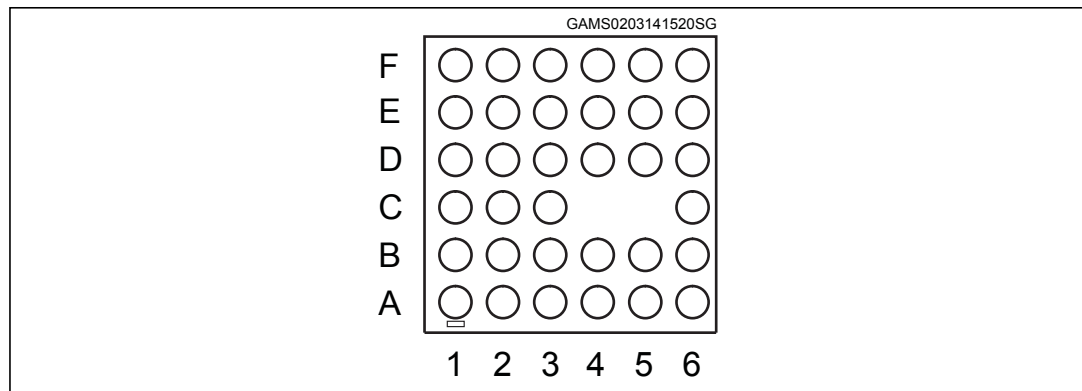

Figure 3. BlueNRG-MS pinout top view (WLCSP34)



Note: Top view (balls are underneath).

Figure 4. BlueNRG-MS pinout bottom view (WLCSP34)

Table 1. Pinout description

Pins		Name	I/O	Description
QFN32	WLCSP			
1	E2	SPI_MOSI	I	SPI_MOSI
2	E1	SPI_CLK	I	SPI_CLK
3	D2	SPI_IRQ	O	SPI_IRQ
4	D1	TEST1	I/O	Test pin
5	C1	VBAT3	VDD	1.7-3.6 battery voltage input
6	C2	TEST2	I/O	Test pin connected to GND
7	B1	TEST3	I/O	Test pin connected to GND
8	B2	TEST4	I/O	Test pin connected to GND
9	A1	TEST5	I/O	Test pin connected to GND
10	B3	TEST6	I/O	Test pin connected to GND
11	A2	TEST7	I/O	Test pin connected to GND
12	A3	VDD1V8	O	1.8 V digital core
13	A4	TEST8	I/O	Test pin not connected
14	A5	TEST9	I/O	Test pin not connected
15	B4	TEST11	I/O	Test pin not connected (QFN32) Test pin connected to GND (WLCSP)
16	B5	TEST12	I/O	Test pin not connected (QFN32) Test pin connected to GND (WLCSP)
17	A6	FXTAL1	I	16/32 MHz crystal
18	B6	FXTAL0	I	16/32 MHz crystal
19	-	VBAT2	VDD	1.8-3.6 battery voltage input
20	C6	RF1	I/O	Antenna + matching circuit
21	D6	RF0	I/O	Antenna + matching circuit
22	E6	SXTAL1	I	32 kHz crystal
23	E5	SXTAL0	I	32 kHz crystal
24	D5	VBAT1	VDD	1.7-3.6 battery voltage input
25	E4	RESETN	I	Reset

Pins		Name	I/O	Description
QFN32	WLCSP			
26	F6	SMPSFILT1	O	SMPS output
27	-	NO_SMPS	I	Power management strategy selection
28	F5	SMPSFILT2	I/O	SMPS input/output
29	F3	VDD1V2	O	1.2 V digital core
30	E3	TEST10	I/O	TEST pin connected to GND
31	F2	SPI_CS	I	SPI_CS
32	F1	SPI_MISO	O	SPI_MISO
-	C3	GND	GND	Ground
-	D3	GND	GND	Ground
-	D4	GND	GND	Ground
-	F4	SMPS-GND	GND	SMPS ground

4 Application circuits

The schematics below are purely indicative. For more detailed schematics, please refer to the "Reference design" and "Layout guidelines" which are provided as separate documents.

Figure 5. BlueNRG-MS application circuit: active DC-DC converter QFN32 package

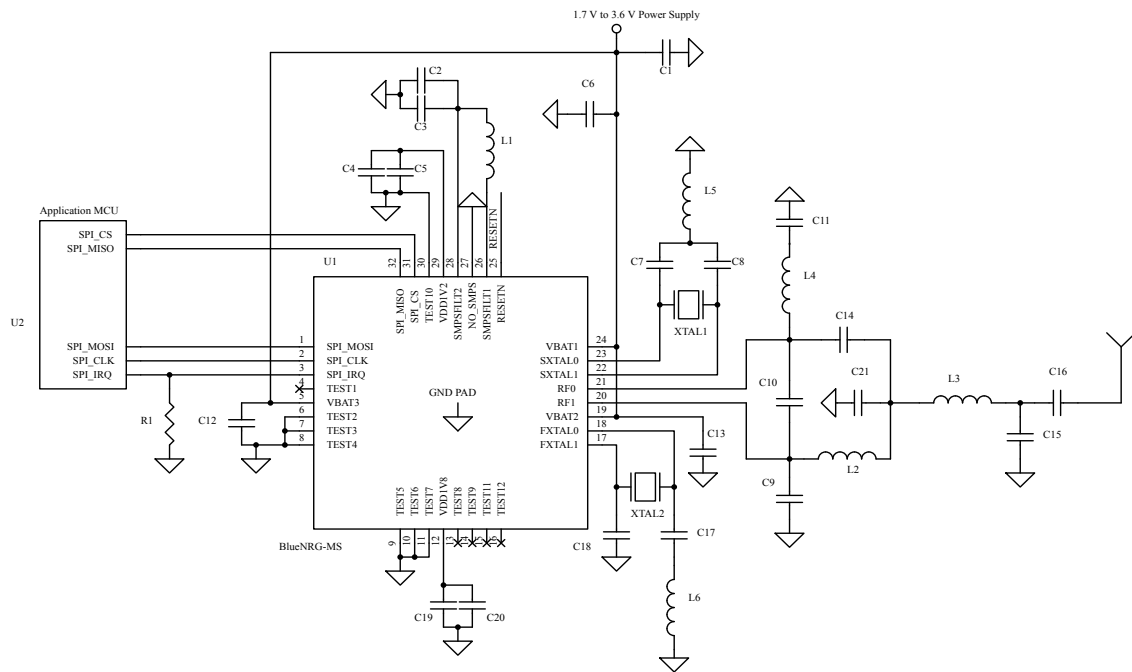

GAMS20150615EC-1005

Figure 6. BlueNRG-MS application circuit: non active DC-DC converter QFN32 package

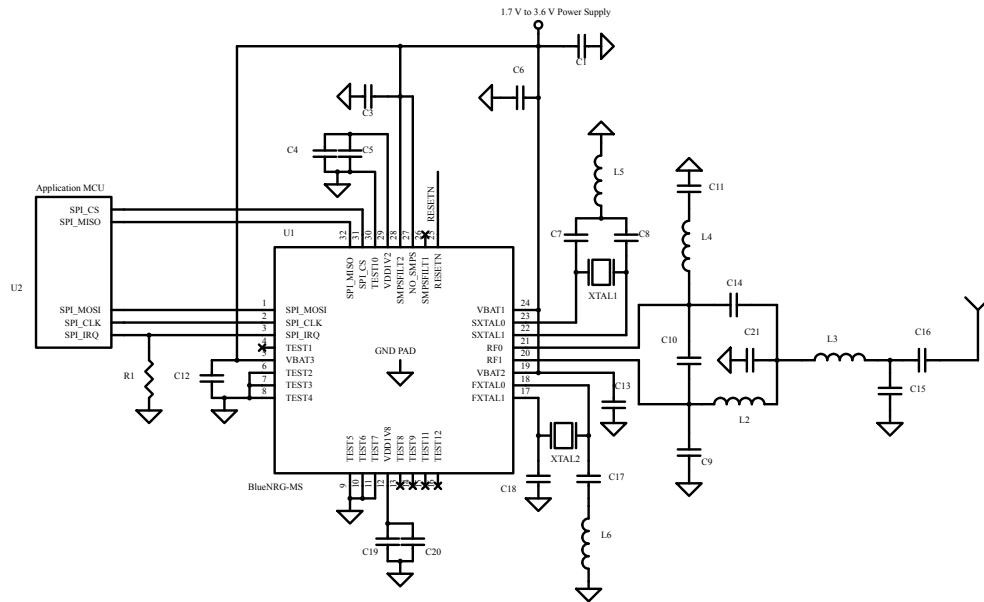

GAMS20150615EC-1006

Figure 7. BlueNRG-MS application circuit: active DC-DC converter WLCSP package

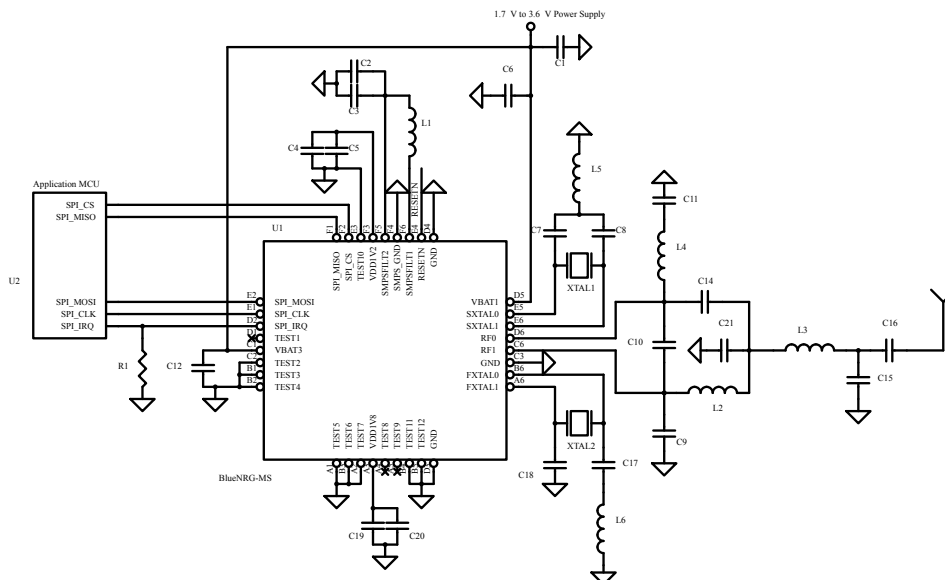

GAMS20150615EC-1007

Figure 8. BlueNRG-MS application circuit: non active DC-DC converter WLCSP package

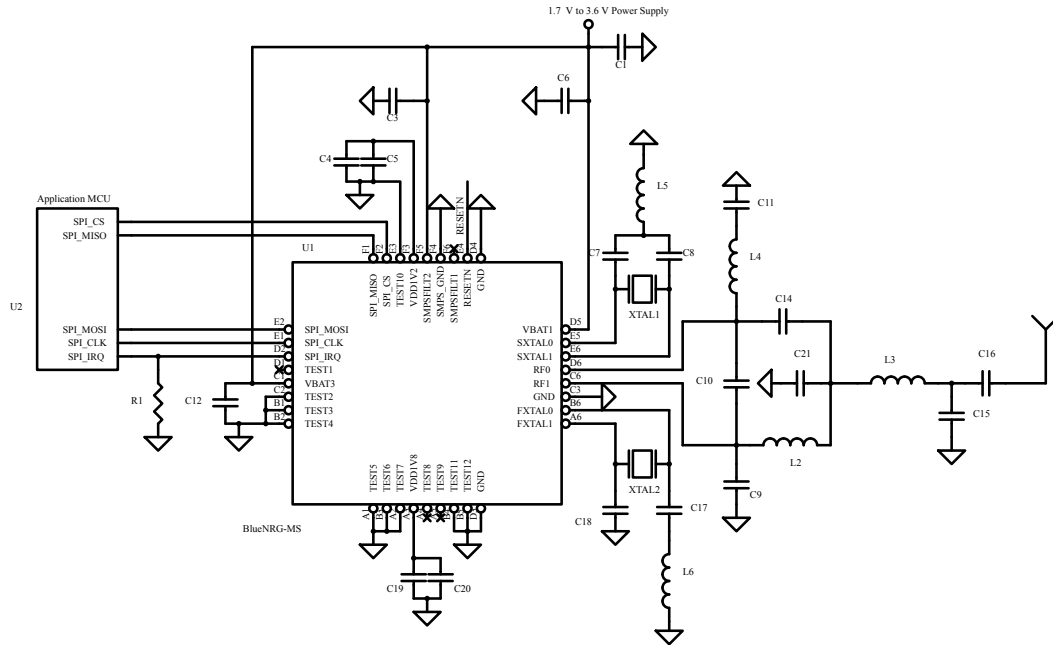

GAMS20150615EC-1008

Table 2. External component list

Component	Description
C1	Decoupling capacitor
C2	DC-DC converter output capacitor
C3	DC-DC converter output capacitor
C4	Decoupling capacitor for 1.2 V digital regulator
C5	Decoupling capacitor for 1.2 V digital regulator
C6	Decoupling capacitor
C7	32 kHz crystal loading capacitor ⁽¹⁾
C8	32 kHz crystal loading capacitor Section 4 (1)
C9	RF balun/matching network capacitor high performance RF balun/matching network capacitor standard mode
C10	RF balun/matching network capacitor High Performance RF balun/matching network capacitor Standard mode
C11	RF balun/matching network capacitor high performance RF balun/matching network capacitor standard mode
C12	Decoupling capacitor
C13	Decoupling capacitor
C14	RF balun/matching network capacitor high performance RF balun/matching network capacitor standard mode

Component	Description
C15	RF balun/matching network capacitor high performance RF balun/matching network capacitor standard mode
C16	RF balun/matching network capacitor high performance RF balun/matching network capacitor standard mode
C17	16/32 MHz crystal loading capacitor
C18	16/32 MHz crystal loading capacitor
C19	Decoupling capacitor for 1.8 V digital regulator
C20	Decoupling capacitor for 1.8 V digital regulator
C21	RF balun/matching network capacitor high performance, RF balun/matching network capacitor standard mode
L1	DC-DC converter input inductor, Isat > 100 mA, Q > 25
L2	RF balun/matching network inductor high performance RF balun/matching network inductor standard mode
L3	RF balun/matching network inductor high performance RF balun/matching network inductor standard mode
L4	RF balun/matching network inductor high performance RF balun/matching network inductor standard mode
R1	Pull-down resistor on the SPI_IRQ line (can be replaced by the internal pull-down of the application MCU)
XTAL1	32 kHz crystal (optional)
XTAL2	16/32 MHz crystal

1. Values valid only for the crystal NDK NX3215SA-32.768 kHz-EXS00A-MU00003. For other crystals refer to what specified in their datasheet.

5 Block diagram and descriptions

A block diagram of the device is shown in [Figure 9. Block diagram](#). In the following subsections a short description of each module is given.

Figure 9. Block diagram

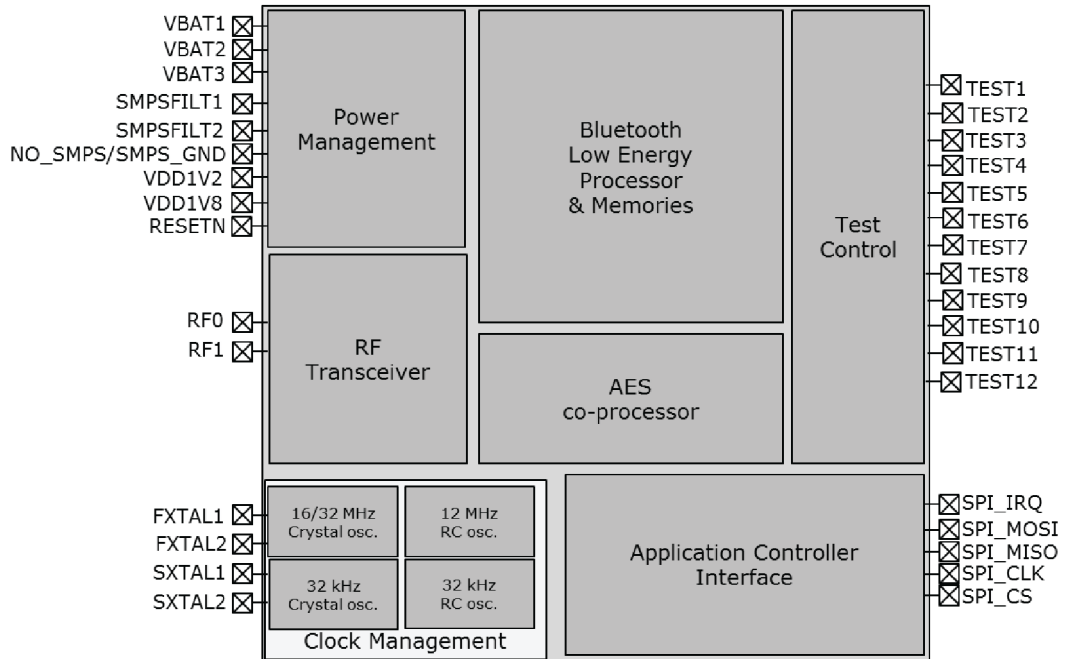

5.1 Core, memory and peripherals

The BlueNRG-MS contains an ARM Cortex-M0 microcontroller core that supports ultra-low leakage state retention mode and almost instantaneously returning to fully active mode on critical events.

The memory subsystem consists of 64 kB Flash, and 12 kB RAM, divided in two blocks of 6 kB (RAM1 and RAM2). Flash is used for the M0 program. No RAM or FLASH resources are available to the external microcontroller driving the BlueNRG-MS.

The application controller interface (ACI) uses a standard SPI slave interface as transport layer, basing in five physical wires:

- 2 control wires (clock and slave select)
- 2 data wires with serial shift-out (MOSI and MISO) in full duplex
- 1 wire to indicate data availability from the slave

Table 3. SPI interface

Name	Direction	Width	Description
SPI_CS	In	1	SPI slave select = SPI enable
SPI_CLK	In	1	SPI clock (max. 8 MHz)
SPI_MOSI	In	1	Master output, slave input
SPI_MISO	Out	1	Master input, slave output
SPI_IRQ	Out	1	Slave has data for master

All the SPI pins have an internal pull-down except for the CSN that has a pull-up. All the SPI pins, except the CSN, are in high impedance state during the low-power states. The IRQ pin needs a pull-down external resistor. The device embeds a battery level detector to monitor the supply voltage. The characteristics of the battery level detector are defined in Table 18. Auxiliary blocks characteristics.

5.2 Power management

The BlueNRG-MS integrates both a low dropout voltage regulator (LDO) and a step-down DC-DC converter, and one of them can be used to power the internal BlueNRG-MS circuitry. However even when the LDO is used, the stringent maximum current requirements, which are advisable when coin cell batteries are used, can be met and further improvements can be obtained with the DC-DC converter at the sole additional cost of an inductor and a capacitor.

The internal LDOs supplying both the 1.8 V digital blocks and 1.2 V digital blocks require decoupling capacitors for stable operation. When the VBAT voltage is below 1.8 V, the LDO 1.8 V output follows the VBAT value.

Figure 10. Power management strategy using LDO and Figure 11. Power management strategy using step-down DC-DC converter, show the simplified power management schemes using LDO and DC-DC converter.

Figure 10. Power management strategy using LDO

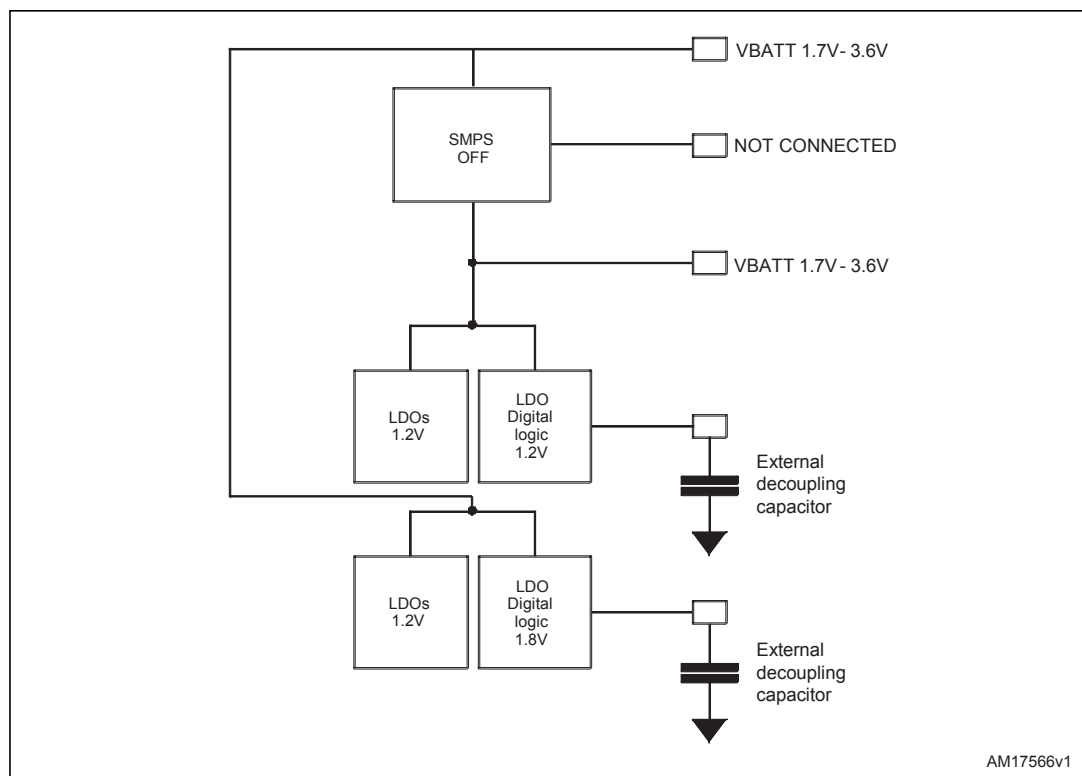
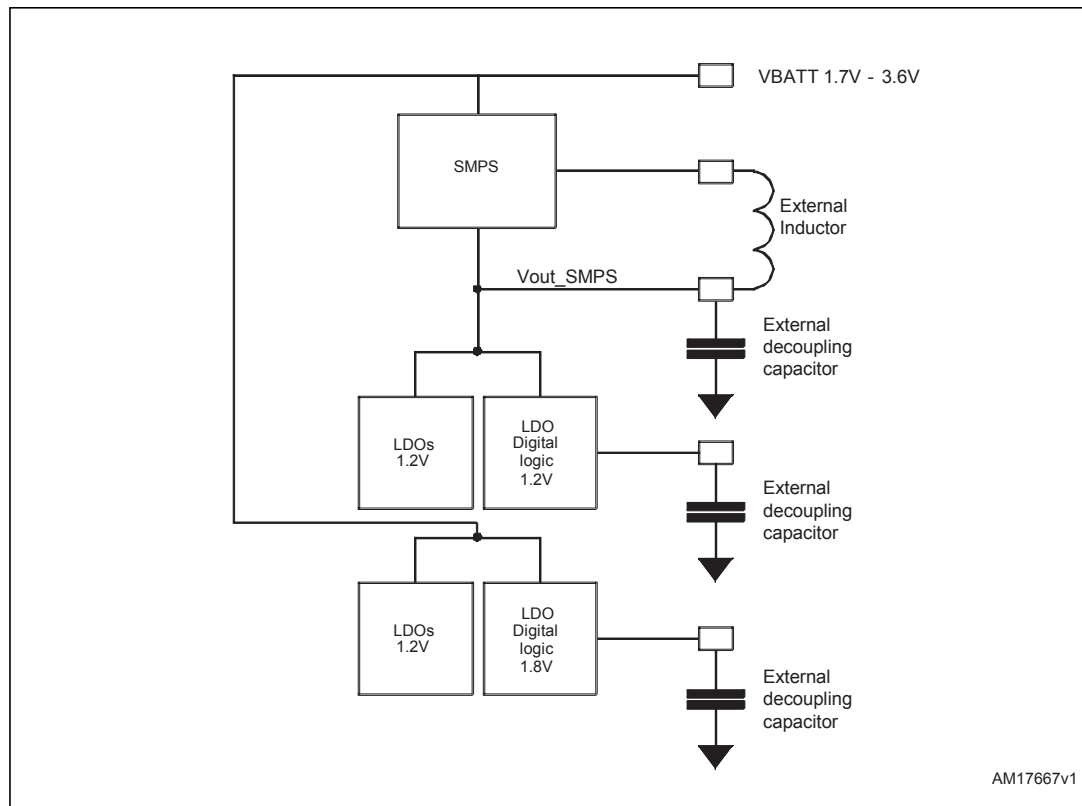

Figure 11. Power management strategy using step-down DC-DC converter



5.3 Clock management

The BlueNRG-MS integrates two low-speed frequency oscillators (LSOSC) and two High speed (16 MHz or 32 MHz) frequency oscillators (HSOSC).

The low frequency clock is used in Low Power mode and can be supplied either by a 32.7 kHz oscillator that uses an external crystal and guarantee up to ± 50 ppm frequency tolerance, or by a ring oscillator with maximum ± 500 ppm frequency tolerance, which does not require any external components.

The primary high frequency clock is a 16 MHz or 32 MHz crystal oscillator. There is also a fast-starting 12 MHz ring oscillator that provides the clock while the crystal oscillator is starting up. Frequency tolerance of high speed crystal oscillator is ± 50 ppm.

The usage of the 16 MHz (or 32 MHz) crystal is strictly necessary.

5.4 Bluetooth low energy radio

The BlueNRG-MS integrates a RF transceiver compliant to the Bluetooth specification and to the standard national regulations in the unlicensed 2.4 GHz ISM band.

The RF transceiver requires very few external discrete components. It provides 96 dB link budgets with excellent link reliability, keeping the maximum peak current below 15 mA.

In Transmit mode, the power amplifier (PA) drives the signal generated by the frequency synthesizer out to the antenna terminal through a very simple external network. The power delivered as well as the harmonic content depends on the external impedance seen by the PA.

The output power is programmable from -18 dBm to +8 dBm, to allow a user-defined power control system and to guarantee optimum power consumption for each scenario.

6 Operating modes

Several operating modes are defined for the BlueNRG-MS:

- Reset mode
- Sleep mode
- Standby mode
- Active mode
- Radio mode
 - Receive radio mode
 - Transmit radio mode

In reset mode, the BlueNRG-MS is in ultra-low power consumption: all voltage regulators, clocks and the RF interface are not powered. The BlueNRG-MS enters Reset mode by asserting the external reset signal. As soon as it is de-asserted, the device follows the normal activation sequence to transit to Active mode.

In sleep mode either the low speed crystal oscillator or the low speed ring oscillator are running, whereas the high speed oscillators are powered down as well as the RF interface. The state of the BlueNRG-MS is retained and the content of the RAM is preserved. Depending on the application, part of the RAM (RAM2 block) can be switched off during sleep to save more power (refer to stack mode 1, described in UM1868).

While in sleep mode, the BlueNRG-MS waits until an internal timer expires and then it goes into Active mode. The transition from Sleep mode to Active mode can also be activated through the SPI interface.

Standby mode and Sleep mode are equivalent but the low speed frequency oscillators are powered down. In Standby mode the BlueNRG-MS can be activated through the SPI interface.

In Active mode the BlueNRG-MS is fully operational: all interfaces, including SPI and RF, are active as well as all internal power supplies together with the high speed frequency oscillator. The MCU core is also running.

Radio mode differs from Active mode as also the RF transceiver is active and it is capable of either transmitting or receiving.

Figure 12. Simplified state machine reports the simplified state machine:

Figure 12. Simplified state machine

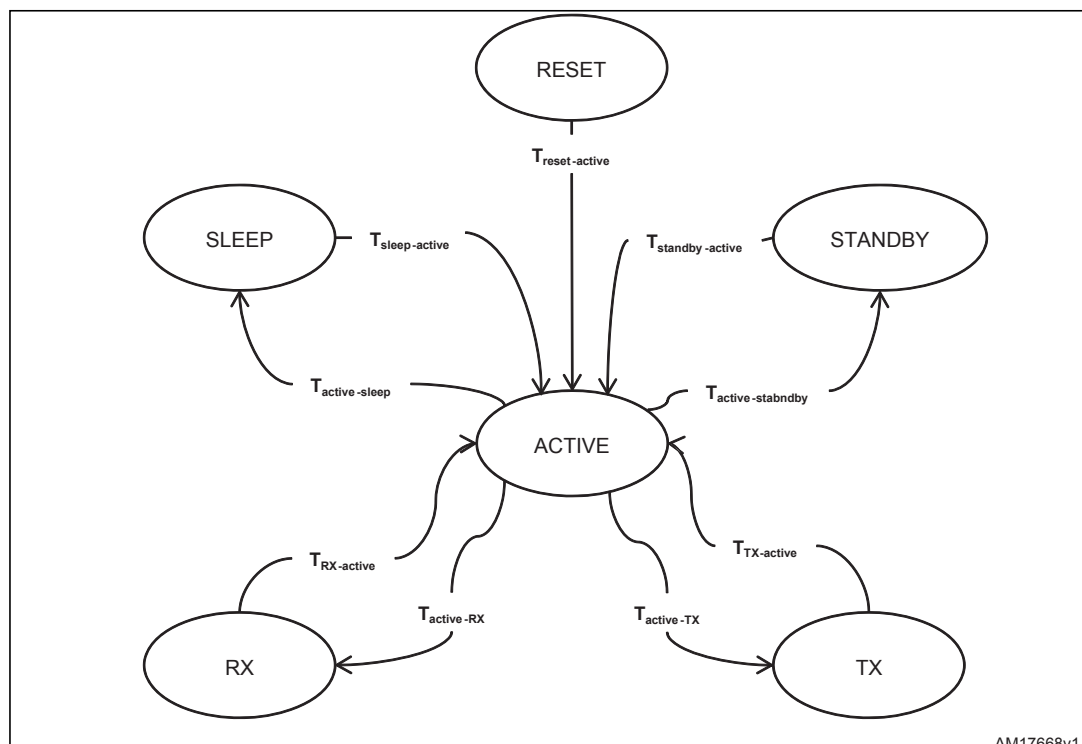

Table 4. BlueNRG-MS operating modes

State	Digital LDO	SPI	LSOSC	HSOSC	Core	RF synt.	RX chain	TX chain
Reset	OFF Register contents lost	OFF	OFF	OFF	OFF	OFF	OFF	OFF
Standby	ON Register contents retained	ON	OFF	OFF	OFF	OFF	OFF	OFF
Sleep	ON Register contents retained	ON	ON	OFF	OFF	OFF	OFF	OFF
Active	ON Register contents retained	ON	-	ON	ON	OFF	OFF	OFF
RX	ON Register contents retained	ON	-	ON	ON	ON	ON	OFF
TX	ON Register contents retained	ON	-	ON	ON	ON	OFF	ON

Table 5. BlueNRG-MS transition times

Transition	Maximum time	Condition
Reset-active ⁽¹⁾	1.5 ms	32 kHz not available
	7 ms	32 kHz RO
	94 ms	32 kHz XO
Standby-active ⁽¹⁾	0.42 ms	32 kHz not available
	6.2 ms	32 kHz RO
	93 ms	32 kHz XO
Sleep-active ⁽¹⁾	0.42 ms	
Active-RX	125 μs	Channel change
	61 μs	No channel change
Active-TX	131 μs	Channel change
	67 μs	No channel change
RX-TX or TX-RX	150 μs	

1. These measurements are taken using NX3225SA-16.000 MHz-EXS00A-CS05997.

7 Application controller interface

The application controller interface (ACI) is based on a standard SPI module with speeds up to 8 MHz. The ACI defines a protocol providing access to all the services offered by the layers of the embedded Bluetooth stack. The ACI commands are described in the BlueNRG-MS ACI command interface document (UM1865). In addition, the ACI provides a set of commands that allow to program BlueNRG-MS firmware from an external device connected to SPI. The complete description of updater commands and procedures is provided in a separate application note (AN4491).

8 Absolute maximum ratings and thermal data

Absolute maximum ratings are those values above which damage to the device may occur. Functional operation under these conditions is not implied. All voltages are referred to GND.

Table 6. Absolute maximum ratings

Pin	Parameter	Value	Unit
5, 19, 24, 26, 28	DC-DC converter supply voltage input and output	-0.3 to +3.9	V
12, 29	DC voltage on linear voltage regulator	-0.3 to +3.9	V
1, 2, 3, 4, 6, 7, 8, 9, 10, 11, 25, 27, 30, 31, 32	DC voltage on digital input/output pins	-0.3 to +3.9	V
13, 14, 15, 16	DC voltage on analog pins	-0.3 to +3.9	V
17, 18, 22, 23	DC voltage on XTAL pins	-0.3 to +1.4	V
20, 21 ⁽¹⁾	DC voltage on RF pins	-0.3 to +1.4	V
T _{STG}	Storage temperature range	-40 to +125	°C
V _{ESD-HBM}	Electrostatic discharge voltage	±2.0	kV

1. +8 dBm input power at antenna connector in standard mode, +11 dBm in high power mode, with given reference design.

Table 7. Thermal data

Symbol	Parameter	Value	Unit
R _{thj-amb}	Thermal resistance junction-ambient	34 (QFN32) 50 (WLCSP36)	°C/W
R _{thj-c}	Thermal resistance junction-case	2.5 (QFN32) 25 (WLCSP36)	°C/W

9 General characteristics

Table 8. Recommended operating conditions

Symbol	Parameter	Min.	Typ.	Max.	Unit
V _{BAT}	Operating battery supply voltage	1.7	—	3.6	V
T _A	Operating ambient temperature range	-40	—	+85	°C

10 Electrical specification

10.1 Electrical characteristics

Characteristics measured over recommended operating conditions unless otherwise specified. Typical value are referred to $T_A = 25\text{ }^\circ\text{C}$, $V_{BAT} = 3.0\text{ V}$. All performance data are referred to a 50 W antenna connector, via reference design, QFN32 package version.

Table 9. Electrical characteristics

Symbol	Parameter	Test conditions	Min.	Typ.	Max.	Unit	
Power consumption when DC-DC converter active							
I_{BAT}	Supply current	Reset		5		nA	
		Standby	RAM2 OFF		1.3		μA
			RAM2 ON		2		
		Sleep	32 kHz XO ON (RAM2 OFF)		1.7		μA
			32 kHz XO ON (RAM2 ON)		2.4		
			32 kHz RO ON (RAM2 OFF)		2.8		
			32 kHz RO ON (RAM2 ON)		3.5		
		Active	CPU, Flash and RAM on		2		mA
		RX	High power mode		7.7		mA
			Standard mode		7.3		
		TX standard mode	+5 dBm		11		mA
			0 dBm		8.2		
			-2 dBm		7.2		
			-6 dBm		6.7		
			-9 dBm		6.3		
			-12 dBm		6.1		
			-15 dBm		5.9		
			-18 dBm		5.8		
		TX high power mode	+8 dBm		15.1		mA
			+4 dBm		10.9		
+2 dBm			9				
-2 dBm			8.3				
-5 dBm			7.7				
Power consumption when DC-DC converter not active							

Symbol	Parameter	Test conditions	Min.	Typ.	Max.	Unit		
I_{BAT}	Supply current	Reset		5		nA		
		Standby	RAM2 OFF		1.4		μ A	
			RAM2 ON		2			
		Sleep	32 kHz XO ON (RAM2 OFF)		1.7		μ A	
			32kHz XO ON (RAM2 ON)		2.4			
			32 kHz RO ON (RAM2 OFF)		2.8			
			32 kHz RO ON (RAM2 ON)		3.5			
		Active CPU, Flash and RAM on			2		mA	
		RX	High power mode			14.5		mA
			Standard mode			14.3		
		TX standard mode	+5 dBm			21		mA
			0 dBm			15.4		
			-2 dBm			13.3		
			-6 dBm			12.2		
			-9 dB			11.5		
			-12 dBm			11		
			-15 dBm			10.6		
			-18 dBm			10.4		
		TX high power mode	+8 dBm			28.8		mA
			+4 dBm			20.5		
+2 dBm				17.2				
-2 dBm				15.3				
-5 dBm				14				
-8 dBm				13				
-11 dBm				12.3				
-14 dBm				12				
Digital I/O								
C_{IN}	Port I/O capacitance			1.29	1.38	1.67	pF	
T_{RISE}	Rise time	0.1*VDD to 0.9*VDD, CL = 50 pF		5		19	ns	
T_{FALL}	Fall time	0.9*VDD to 0.1*VDD, CL = 50 pF		6		22	ns	
$T(RST)$	Hold time for reset			-	1.5		ms	
TC	V_{BAT} range			3.0	3.3	3.6	V	
TC1	V_{BAT} range			2.25	2.5	2.75	V	

Symbol	Parameter	Test conditions	Min.	Typ.	Max.	Unit
TC2	V _{BAT} range		1.7	1.8	1.98	V
VIL	Input low voltage	V _{BAT} range: TC	-0.3		0.8	V
		V _{BAT} range: TC1	-0.3		0.7	
		V _{BAT} range: TC2	-0.3		0.63	
VIH	Input high voltage	V _{BAT} range: TC	2.0		3.6	V
		V _{BAT} range: TC1	1.7		3.6	
		V _{BAT} range: TC2	1.17		3.6	
VOL	Output low voltage	V _{BAT} range: TC			0.4	V
		V _{BAT} range: TC1			0.7	
		V _{BAT} range: TC2			0.45	
VOH	Output high voltage	V _{BAT} range: TC	2.4			V
		V _{BAT} range: TC1	1.7			
		V _{BAT} range: TC2	1.35			
IOL	Low level output current @ VOL (max.)	V _{BAT} range: TC	3.4	5.6	7.9	mA
		V _{BAT} range: TC1	3.8	6.6	10.1	
		V _{BAT} range: TC2	1.6	3	5	
IOH	High level output current @ VOH (min.)	V _{BAT} range: TC	5.5	10.6	17.6	mA
		V _{BAT} range: TC1	3.7	7.2	12.0	
		V _{BAT} range: TC2	1.4	3	5.6	

10.2 RF general characteristics

Characteristics measured over recommended operating conditions unless otherwise specified. Typical value are referred to $T_A = 25\text{ }^\circ\text{C}$, $V_{BAT} = 3.0\text{ V}$. All performance data are referred to a 50 W antenna connector, via reference design, QFN32 package version.

Table 10. RF general characteristics

Symbol	Parameter	Test conditions	Min.	Typ.	Max.	Unit
FREQ	Frequency range		2400	–	2483.5	MHz
F _{CH}	Channel spacing		–	2	–	MHz
RF _{ch}	RF channel center frequency		2402	–	2480	MHz

10.3 RF transmitter characteristics

Characteristics measured over recommended operating conditions unless otherwise specified. Typical value are referred to $T_A = 25\text{ }^\circ\text{C}$, $V_{BAT} = 3.0\text{ V}$. All performance data are referred to a 50 W antenna connector, via reference design, QFN32 package version.

Table 11. RF Transmitter characteristics

Symbol	Parameter	Test conditions	Min.	Typ.	Max.	Unit
MOD	Modulation scheme		GFSK			
BT	Bandwidth-bit period product		–	0.5	–	
M _{index}	Modulation index		0.45	0.5	0.55	
DR	Air data rate		–	1	–	Mbps
ST _{acc}	Symbol time accuracy		–	–	50	ppm
P _{MAX}	Maximum output power at antenna connector	High power	–	+8	+10	dBm
		Standard mode	–	+5	+7	dBm
P _{RFC}	Minimum output power	High power	–	-15	–	dB
		Standard mode	–	-18	–	
P _{RFC}	RF power accuracy		–	–	±2	dB
P _{BW1M}	6 dB bandwidth for modulated carrier (1 Mbps)	Using resolution bandwidth of 100 kHz	500	–	–	kHz
P _{RF1}	1 st adjacent channel transmit power 2 MHz	Using resolution bandwidth of 100 kHz and average detector	–	–	-20	dBm
P _{RF2}	2 nd adjacent channel transmit power >3 MHz	Using resolution bandwidth of 100 kHz and average detector	–	–	-30	dBm

Symbol	Parameter	Test conditions	Min.	Typ.	Max.	Unit
P _{SPUR}	Spurious emission	Harmonics included. Using resolution bandwidth of 1 MHz and average detector	–	–	–41	dBm
CF _{dev}	Center frequency deviation	During the packet and including both initial frequency offset and drift	–	–	±150	kHz
Freq _{drift}	Frequency drift	During the packet	–	–	±50	kHz
IFreq _{drift}	Initial carrier frequency drift		–	–	±20	kHz
DriftRate _{max}	Maximum drift rate		–	–	400	Hz/μs
Z _{LOAD}	Optimum differential load	Standard mode @ 2440 MHz	–	25.9 + j44.4	–	Ω
		High power mode @ 2440 MHz	–	25.4 + j20.8	–	

10.4 RF receiver characteristics

Characteristics measured over recommended operating conditions unless otherwise specified. Typical value are referred to T_A = 25 °C, V_{BAT} = 3.0 V. All performance data are referred to a 50 W antenna connector, via reference design, QFN32 package version.

Table 12. RF receiver characteristics

Symbol	Parameter	Test conditions	Min.	Typ.	Max.	Unit
RX _{SENS}	Sensitivity	BER <0.1%		–88	–	dBm
P _{SAT}	Saturation	BER <0.1%	–	8	–	dBm
	Standard mode High power mode			11		
Z _{IN}	Input differential impedance	Standard mode @ 2440 MHz		31.4 - j26.6	–	Ω
		High power mode @ 2440 MHz		28.8 - j18.5		
RF selectivity with BLE equal modulation on interfering signal						

Symbol	Parameter	Test conditions	Min.	Typ.	Max.	Unit
$C/I_{CO-channel}$	Co-channel interference	Wanted signal = -67 dBm, BER \leq 0.1%	-	9	-	dBc
$C/I_{1\text{ MHz}}$	Adjacent (+1 MHz) Interference	Wanted signal = -67 dBm, BER \leq 0.1%		2	-	dBc
$C/I_{2\text{ MHz}}$	Adjacent (+2 MHz) Interference	Wanted signal = -67 dBm, BER \leq 0.1%		-34	-	dBc
$C/I_{3\text{ MHz}}$	Adjacent (+3 MHz) Interference	Wanted signal = -67 dBm, BER \leq 0.1%		-40	-	dBc
$C/I_{\geq 4\text{ MHz}}$	Adjacent ($\geq \pm 4$ MHz) Interference	Wanted signal = -67 dBm, BER \leq 0.1%		-34	-	dBc
$C/I_{\geq 6\text{ MHz}}$	Adjacent ($\geq \pm 6$ MHz) Interference	Wanted signal = -67 dBm, BER \leq 0.1%		-45	-	dBc
$C/I_{\geq 25\text{ MHz}}$	Adjacent ($\geq \pm 25$ MHz) Interference	Wanted signal = -67 dBm, BER \leq 0.1%		-64	-	dBc
C/I_{Image}	Image frequency Interference -2MHz	Wanted signal = -67 dBm, BER \leq 0.1%		-20	-	dBc
$C/I_{Image \pm 1\text{ MHz}}$	Adjacent (± 1 MHz) Interference to in-band image frequency -1MHz -3MHz	Wanted signal = -67 dBm, BER \leq 0.1%	5 -25	-	dBc	
Out of Band Blocking (Interfering signal CW)						
C/I_{Block}	Interfering signal frequency 30 MHz – 2000 MHz	Wanted signal = -67 dBm, BER \leq 0.1%, Measurement resolution 10 MHz	-	-	-30	dBm
C/I_{Block}	Interfering signal frequency 2003 MHz – 2399 MHz	Wanted signal = -67 dBm, BER \leq 0.1%, Measurement resolution 3 MHz		-	-35	dBm
C/I_{Block}	Interfering signal frequency 2484 MHz – 2997 MHz	Wanted signal = -67 dBm, BER \leq 0.1%, measurement resolution 3 MHz		-	-35	dBm
C/I_{Block}	Interfering signal frequency 3000 MHz – 12.75 GHz	Wanted signal = -67 dBm, BER \leq 0.1%, measurement resolution 25 MHz		-	-30	dBm
Intermodulation characteristics (CW signal at f_1 , BLE interfering signal at f_2)						
$P_{IM(3)}$	Input power of IM interferes at 3 and 6 MHz distance from wanted signal	Wanted signal = -64 dBm, BER \leq 0.1%	-	-33	-	dBm
$P_{IM(-3)}$	Input power of IM interferes at -3 and -6 MHz distance from wanted signal	Wanted signal = -64 dBm, BER \leq 0.1%		-43	-	dBm
$P_{IM(4)}$	Input power of IM interferes at ± 4 and ± 8 MHz distance from wanted signal	Wanted signal = -64 dBm, BER \leq 0.1%		-33	-	dBm
$P_{IM(5)}$	Input power of IM interferes at ± 5 and ± 10 MHz distance from wanted signal	Wanted signal = -64 dBm, BER \leq 0.1%		-33	-	dBm

10.5 High speed crystal oscillator (HSXOSC) characteristics

Characteristics measured over recommended operating conditions unless otherwise specified. Typical value are referred to $T_A = 25\text{ }^\circ\text{C}$, $V_{BAT} = 3.0\text{ V}$.

Table 13. High speed crystal oscillator characteristics

Symbol	Parameter	Test conditions	Min.	Typ.	Max.	Unit
f_{NOM}	Nominal frequency		-	16/32	-	MHz
f_{TOL}	Frequency tolerance	Includes initial accuracy, stability over temperature, aging and frequency pulling due to incorrect load capacitance.	-	-	± 50	ppm
ESR	Equivalent series resistance		-	-	100	Ω
P_D	Drive level		-	-	100	μW

10.5.1 High speed crystal oscillator (HSXOSC)

The BlueNRG-MS includes a fully integrated, low power 16/32 MHz Xtal oscillator with an embedded amplitude regulation loop. In order to achieve low power operation and good frequency stability of the Xtal oscillator, certain considerations with respect to the quartz load capacitance C_0 need to be taken into account. Figure 13. Figure 13 shows a simplified block diagram of the amplitude regulated oscillator used on the BlueNRG-MS.

Figure 13. Simplified block diagram of the amplitude regulated oscillator

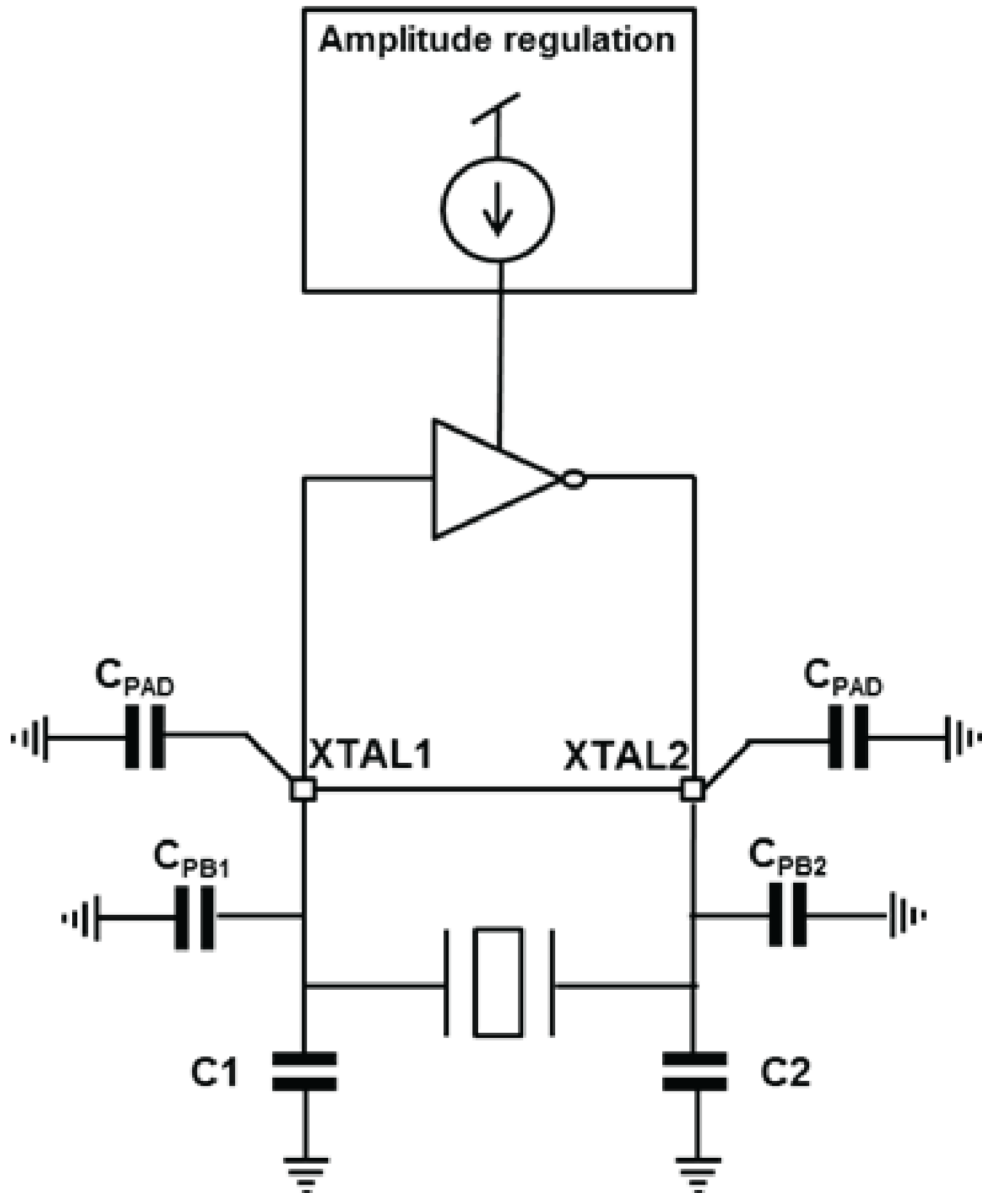

Low power consumption and fast startup time is achieved by choosing a quartz crystal with a low load capacitance C_0 . To achieve good frequency stability, the following equation needs to be satisfied:

$$C_0 = \frac{C_1' * C_2'}{C_1' + C_2'} \quad (1)$$

Where $C_1' = C_1 + C_{PCB1} + C_{PAD}$, $C_2' = C_2 + C_{PCB2} + C_{PAD}$, where C_1 and C_2 are external (SMD) components, C_{PCB1} and C_{PCB2} are PCB routing parasites and C_{PAD} is the equivalent small-signal pad-capacitance. The value of C_{PAD} is around 0.5 pF for each pad. The routing parasites should be minimized by placing quartz and

C1/C2 capacitors close to the chip, not only for an easier matching of the load capacitance C_0 , but also to ensure robustness against noise injection. Connect each capacitor of the Xtal oscillator to ground by a separate via.

10.6 Low speed crystal oscillator (LSXOSC) characteristics

Characteristics measured over recommended operating conditions unless otherwise specified. Typical value are referred to $T_A = 25\text{ }^\circ\text{C}$, $V_{BAT} = 3.0\text{ V}$.

Table 14. Low speed crystal oscillator characteristics

Symbol	Parameter	Test conditions	Min.	Typ.	Max.	Unit
f_{NOM}	Nominal frequency		–	32.768	–	kHz
f_{TOL}	Frequency tolerance	Includes initial accuracy, stability over temperature, aging and frequency pulling due to incorrect load capacitance.	–	–	±50	ppm
ESR	Equivalent series resistance		–	–	90	kΩ
P_D	Drive level		–	–	0.1	μW

Note: These values are the correct ones for NX3215SA-32.768 kHz-EXS00A-MU00003.

10.7 High speed ring oscillator (HSROSC) characteristics

Characteristics measured over recommended operating conditions unless otherwise specified. Typical value are referred to $T_A = 25\text{ }^\circ\text{C}$, $V_{BAT} = 3.0\text{ V}$, QFN32 package version.

Table 15. High speed ring oscillator characteristics

Symbol	Parameter	Test conditions	Min.	Typ.	Max.	Unit
f_{NOM}	Nominal $f_{Frequency}$		–	12	16	MHz

10.8 Low speed ring oscillator (LSROSC) characteristics

Characteristics measured over recommended operating conditions unless otherwise specified. Typical value are referred to $T_A = 25\text{ }^\circ\text{C}$, $V_{BAT} = 3.0\text{ V}$, QFN32 package version.

Table 16. Low speed ring oscillator characteristics

Symbol	Parameter	Test conditions	Min.	Typ.	Max.	Unit
32 kHz ring oscillator (LSROSC)						
f_{NOM}	Nominal frequency		–	37.4	–	kHz
f_{TOL}	Frequency tolerance		–	–	±500	ppm

10.9 N-fractional frequency synthesizer characteristics

Characteristics measured over recommended operating conditions unless otherwise specified. Typical value are referred to $T_A = 25\text{ }^\circ\text{C}$, $V_{BAT} = 3.0\text{ V}$, $f_c = 2440\text{ MHz}$.

Table 17. N-fractional frequency synthesizer characteristics

Symbol	Parameter	Test conditions	Min.	Typ.	Max.	Unit
PN_{SYNTH}	RF carrier phase noise	At ±1 MHz offset from carrier	–	-113	–	dBc/Hz
		At ±3 MHz offset from carrier	–	-119	–	dBc/Hz
$LOCK_{TIME}$	PLL lock time		–	–	40	μs
TO_{TIME}	PLL turn on / hop time	Including calibration	–	–	150	μs

10.10 Auxiliary blocks characteristics

Characteristics measured over recommended operating conditions unless otherwise specified. Typical value are referred to $T_A = 25\text{ }^\circ\text{C}$, $V_{BAT} = 3.0\text{ V}$, $f_c = 2440\text{ MHz}$. QFN32 package version.

Table 18. Auxiliary blocks characteristics

Symbol	Parameter	Test conditions	Min.	Typ.	Max.	Unit
Battery indicator and brown-out reset (BOR) ⁽¹⁾						
V_{BLT1}	Battery level thresholds 1		–	2.7	–	V
V_{BLT2}	Battery level thresholds 2		–	2.5	–	V
V_{BLT3}	Battery level thresholds 3		–	2.3	–	V
V_{BLT4}	Battery level thresholds 4		–	2.1	–	V
A_{BLT}	Battery level thresholds accuracy		–	–	5	%
V_{ABOR}	Ascending brown-out threshold		–	1.79	–	V
V_{DBOR}	Descending brown-out threshold		–	1.73	–	V

1. BOR is disabled by default and it can be enabled by software.

10.11 SPI characteristics

Table 19. SPI characteristics

Symbol	Parameter	Min.	Typ.	Max.	Unit
f_{CLK} $1/t_{(CLK)}$	SPI clock frequency	–	–	8	MHz
$DuCy_{(CLK)}$	SPI clock duty cycle	–	50	–	%
$t_{s(CS)}$	CS setup time	500	–	–	ns
$t_{h(CS)}$	CS low hold time	40	–	–	
$t_{hh(CS)}$	CS high hold time	$10t_{(CLK)}$	–	–	
$t_{s(SI)}$	MOSI setup time	20	–	–	
$t_{h(SI)}$	MOSI hold time	20	–	–	
$t_{v(SO)}$	MISO valid time	–	–	40	

The values for the parameters given in this table are based on characterization, not tested in production.

Figure 14. SPI timings

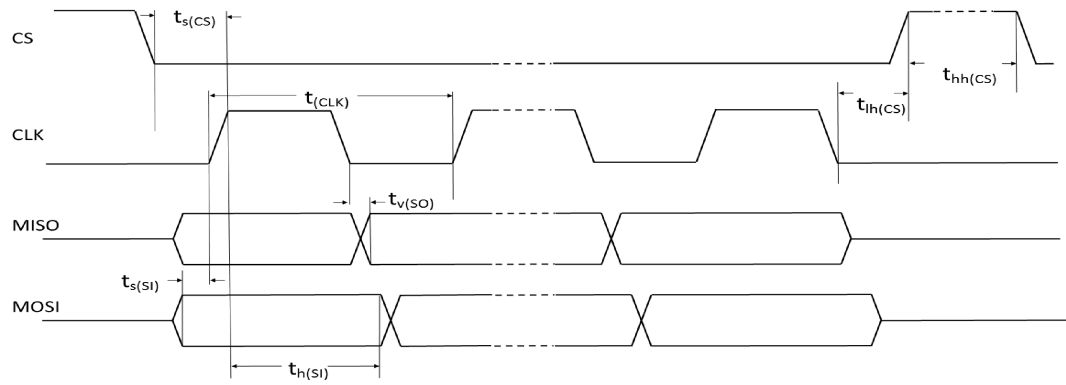

11 Package information

In order to meet environmental requirements, ST offers these devices in different grades of **ECOPACK®** packages, depending on their level of environmental compliance. ECOPACK® specifications, grade definitions and product status are available at: www.st.com. ECOPACK® is an ST trademark.

11.1 QFN32 package information

Figure 15. QFN32 (5 x 5 x 1 pitch 0.5 mm) package outline

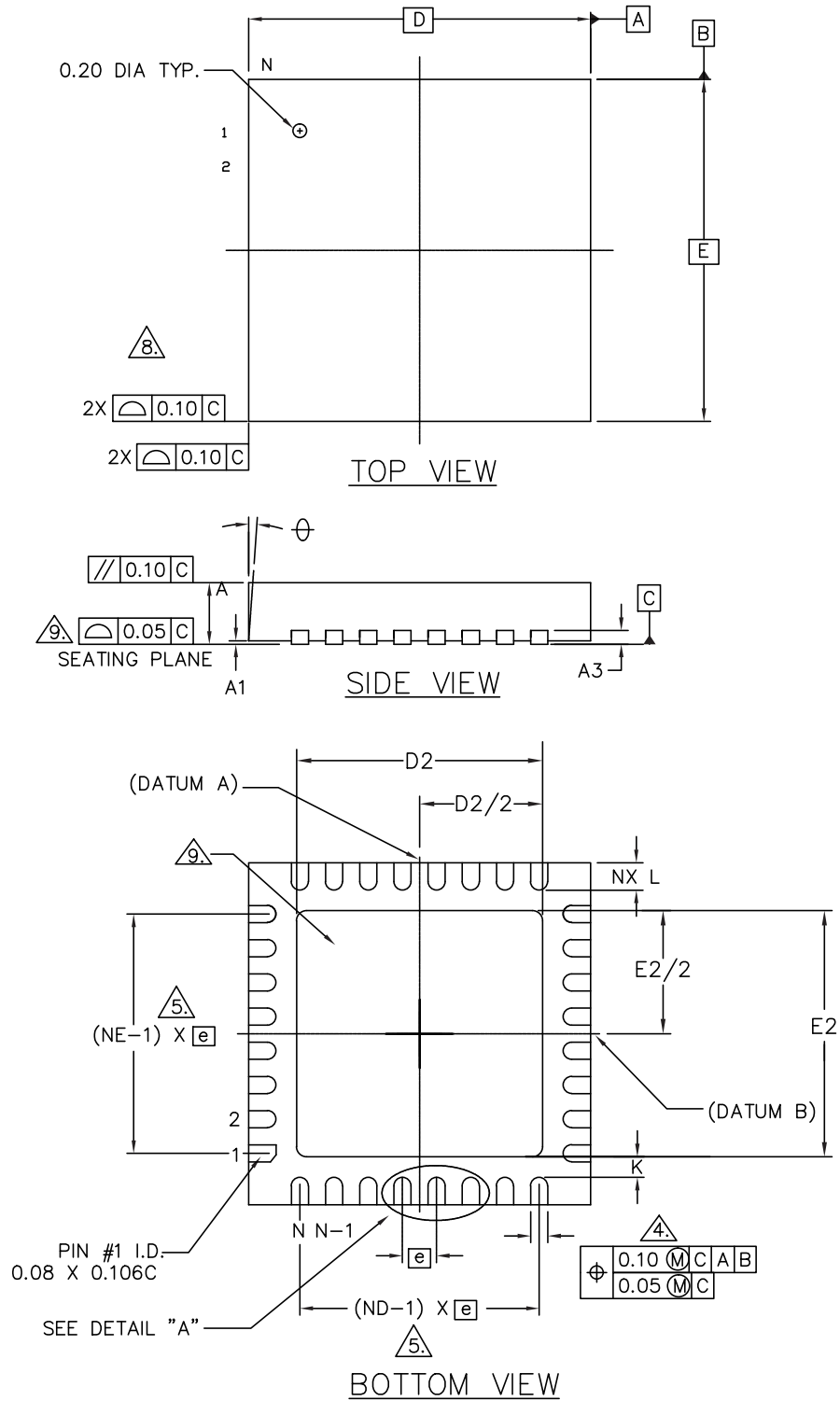

QFN32_POA_8362854_B

Table 20. QFN32 (5 x 5 x 1 pitch 0.5 mm) mechanical data

Dim.	mm		
	Min.	Typ.	Max.
A	0.80	0.85	1.00
A1	0	0.02	0.05
A3	0.20 REF		
b	0.18	0.25	0.30
D	5.00 BSC		
E	5.00 BSC		
D2	3.2		3.70
E2	3.2		3.70
e	0.5 BSC		
L	0.30	0.40	0.50
Φ	0°		14°
K	0.20		

Figure 16. QFN32 (5 x 5 x 1 pitch 0.5 mm) package detail "A"

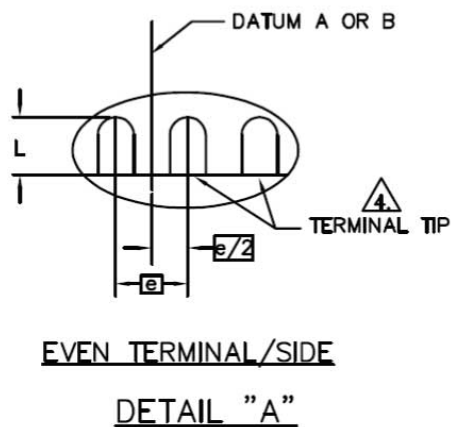

11.2 WLCSP34 package information

Figure 17. WLCSP34 (2.66 x 2.56 x 0.5 pitch 0.4 mm) package outline

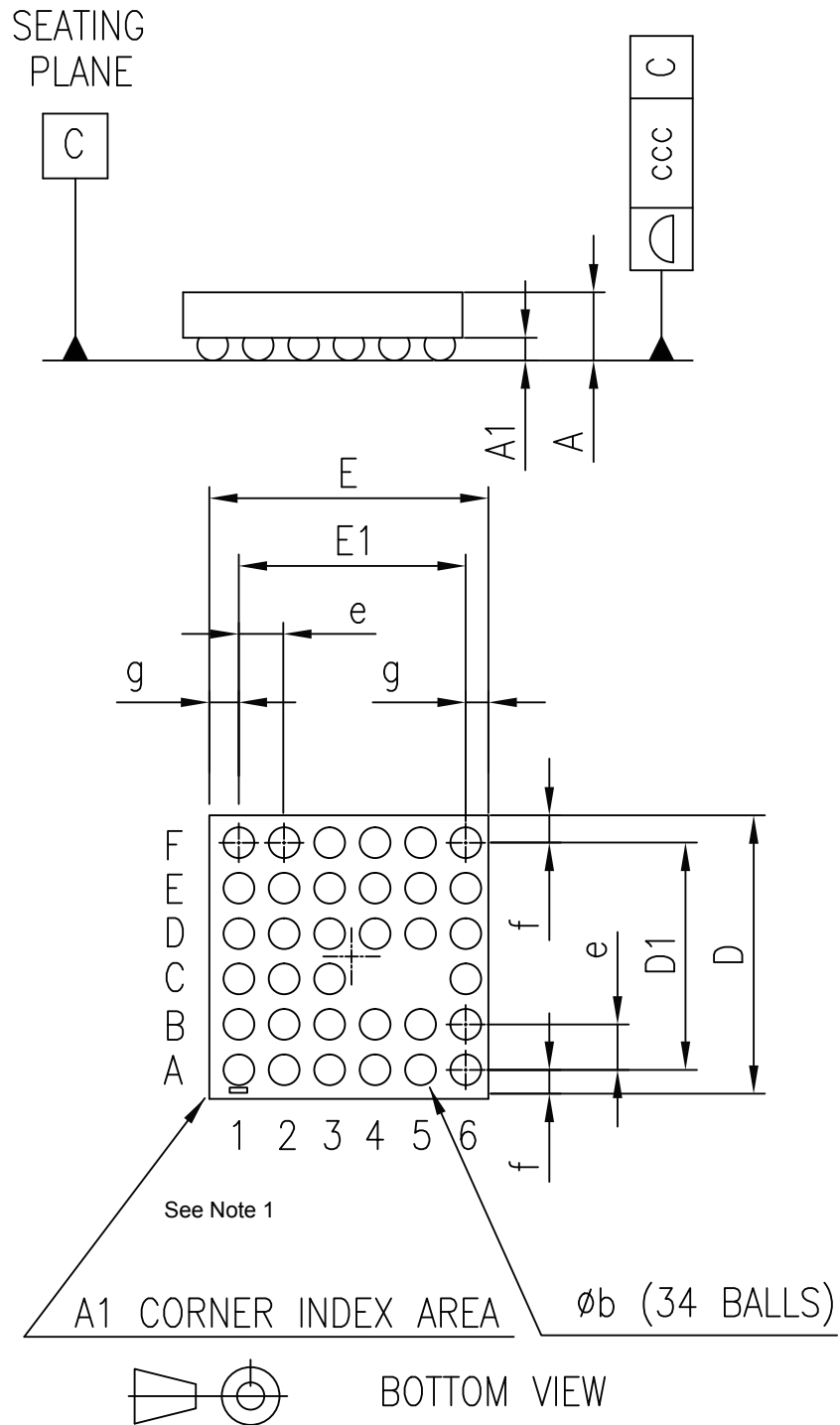

WLCSP34_POA_8165249

1. The corner of terminal A1 must be identified on the top surface by using a laser marking dot.

Table 21. WLCSP34 (2.66 x 2.56 x 0.5 pitch 0.4 mm) mechanical data

Dim.	mm.			Notes
	Min.	Typ.	Max.	
A			0.50	
A1		0.20		
b		0.27		(1)
D	2.50	2.56	2.58	(2)
D1		2.00		
E	2.60	2.66	2.68	(3)
E1		2.00		
e		0.40		
f		0.28		
g		0.33		
ccc			0.05	

1. The typical ball diameter before mounting is 0.25 mm.
2. $D = f + D1 + f$.
3. $E = g + E1 + g$.

12 PCB assembly guidelines

For Flip Chip mounting on the PCB, STMicroelectronics recommends the use of a solder stencil aperture of 330 x 330 μm maximum and a typical stencil thickness of 125 μm . Flip Chips are fully compatible with the use of near eutectic 95.8% Sn, 3.5% Ag, 0.7% Cu solder paste with no-clean flux. ST's recommendations for Flip Chip board mounting are illustrated on the soldering reflow profile shown in Figure 17.

Figure 18. Flip Chip CSP (2.66 x 2.56 x 0.5 pitch 0.4 mm) package reflow profile recommendation

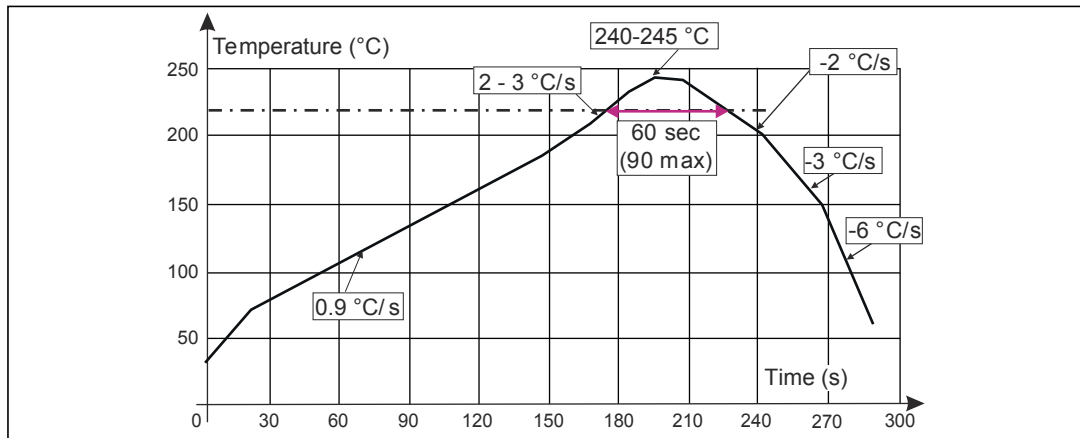

Table 22. Flip Chip CSP (2.66 x 2.56 x 0.5 pitch 0.4 mm) package reflow profile recommendation

Profile	Value	
	Typ.	Max.
Temp. gradient in preheat (T = 70 – 180 °C)	0.9 °C/s	3 °C/s
Temp. gradient (T = 200 – 225 °C)	2 °C/s	3 °C/s
Peak temp. in reflow	240 - 245 °C	260 °C
Time above 220 °C	60 s	90 s
Temp. gradient in cooling	-2 to -3 °C/s	-6 °C/s
Time from 50 to 220 °C	160 to 220 s	

Dwell time in the soldering zone (with temperature higher than 220 °C) has to be kept as short as possible to prevent component and substrate damage. Peak temperature must not exceed 260 °C. Controlled atmosphere (N₂ or N₂H₂) is recommended during the whole reflow, especially above 150 °C.

Flip Chips are able to withstand three times the previous recommended reflow profile to be compatible with a double reflow when SMDs are mounted on both sides of the PCB plus one additional repair.

A maximum of three soldering reflows are allowed for these lead-free packages (with repair step included).

The use of a no-clean paste is highly recommended to avoid any cleaning operation. To prevent any bump cracks, ultrasonic cleaning methods are not recommended.

Revision history

Table 23. Document revision history

Date	Revision	Changes
24-Nov-2014	1	Initial release.
19-Jun-2015	2	Document status promoted from "Preliminary data" to "Production data". Minor changes in the structure of the document to improve readability. Updated: Figure in cover page, Section 2: General description, Figure 5, Figure 6, Figure 7, Figure 8, Section 10: Electrical specification. Added: Figure 15: QFN32 (5 x 5 x 1 pitch 0.5 mm) package detail "A".
01-Oct-2015	3	Modified: Figure 5, Figure 6, Figure 7 and Figure 8
29-Oct-2015	4	Updated: General description. Added: SPI characteristics.
16-Nov-2015	5	Updated title, Features , Section 1: "Description" and Section 2: "General description".
01-Feb-2016	6	Updated Section 8: "Application controller interface".
24-Jan-2017	7	Updated title, Table 20: "SPI characteristics". Minor text edits throughout the document.
12-Nov-2018	8	Updated features and description.
24-Jan-2018	9	Updated Table 9. Electrical characteristics .

Contents

1	Description	2
2	General description	3
3	Pin description	5
4	Application circuits	8
5	Block diagram and descriptions	12
5.1	Core, memory and peripherals	12
5.2	Power management	13
5.3	Clock management	14
5.4	Bluetooth low energy radio	14
6	Operating modes	15
7	Application controller interface	17
8	Absolute maximum ratings and thermal data	18
9	General characteristics	19
10	Electrical specification	20
10.1	Electrical characteristics	20
10.2	RF general characteristics	23
10.3	RF transmitter characteristics	23
10.4	RF receiver characteristics	24
10.5	High speed crystal oscillator (HSXOSC) characteristics	25
10.5.1	High speed crystal oscillator (HSXOSC)	25
10.6	Low speed crystal oscillator (LSXOSC) characteristics	28
10.7	High speed ring oscillator (HSROSC) characteristics	28
10.8	Low speed ring oscillator (LSROSC) characteristics	28
10.9	N-fractional frequency synthesizer characteristics	28
10.10	Auxiliary blocks characteristics	29
10.11	SPI characteristics	29
11	Package information	31
11.1	QFN32 package information	31
11.2	WLCSP34 package information	33

12 PCB assembly guidelines36

Revision history37

List of tables

Table 1.	Pinout description	6
Table 2.	External component list	10
Table 3.	SPI interface	13
Table 4.	BlueNRG-MS operating modes	16
Table 5.	BlueNRG-MS transition times	16
Table 6.	Absolute maximum ratings	18
Table 7.	Thermal data	18
Table 8.	Recommended operating conditions	19
Table 9.	Electrical characteristics	20
Table 10.	RF general characteristics	23
Table 11.	RF Transmitter characteristics	23
Table 12.	RF receiver characteristics	24
Table 13.	High speed crystal oscillator characteristics	25
Table 14.	Low speed crystal oscillator characteristics	28
Table 15.	High speed ring oscillator characteristics	28
Table 16.	Low speed ring oscillator characteristics	28
Table 17.	N-fractional frequency synthesizer characteristics	28
Table 18.	Auxiliary blocks characteristics	29
Table 19.	SPI characteristics	29
Table 20.	QFN32 (5 x 5 x 1 pitch 0.5 mm) mechanical data	33
Table 21.	WLCSP34 (2.66 x 2.56 x 0.5 pitch 0.4 mm) mechanical data	35
Table 22.	Flip Chip CSP (2.66 x 2.56 x 0.5 pitch 0.4 mm) package reflow profile recommendation	36
Table 23.	Document revision history	37

List of figures

Figure 1.	BlueNRG-MS application block diagram.	4
Figure 2.	BlueNRG-MS pinout top view (QFN32)	5
Figure 3.	BlueNRG-MS pinout top view (WLCSP34)	5
Figure 4.	BlueNRG-MS pinout bottom view (WLCSP34)	6
Figure 5.	BlueNRG-MS application circuit: active DC-DC converter QFN32 package.	8
Figure 6.	BlueNRG-MS application circuit: non active DC-DC converter QFN32 package.	9
Figure 7.	BlueNRG-MS application circuit: active DC-DC converter WLCSP package	9
Figure 8.	BlueNRG-MS application circuit: non active DC-DC converter WLCSP package	10
Figure 9.	Block diagram	12
Figure 10.	Power management strategy using LDO	13
Figure 11.	Power management strategy using step-down DC-DC converter.	14
Figure 12.	Simplified state machine	15
Figure 13.	Simplified block diagram of the amplitude regulated oscillator	26
Figure 14.	SPI timings	30
Figure 15.	QFN32 (5 x 5 x 1 pitch 0.5 mm) package outline	32
Figure 16.	QFN32 (5 x 5 x 1 pitch 0.5 mm) package detail "A"	33
Figure 17.	WLCSP34 (2.66 x 2.56 x 0.5 pitch 0.4 mm) package outline	34
Figure 18.	Flip Chip CSP (2.66 x 2.56 x 0.5 pitch 0.4 mm) package reflow profile recommendation.	36

IMPORTANT NOTICE – PLEASE READ CAREFULLY

STMicroelectronics NV and its subsidiaries (“ST”) reserve the right to make changes, corrections, enhancements, modifications, and improvements to ST products and/or to this document at any time without notice. Purchasers should obtain the latest relevant information on ST products before placing orders. ST products are sold pursuant to ST’s terms and conditions of sale in place at the time of order acknowledgement.

Purchasers are solely responsible for the choice, selection, and use of ST products and ST assumes no liability for application assistance or the design of Purchasers’ products.

No license, express or implied, to any intellectual property right is granted by ST herein.

Resale of ST products with provisions different from the information set forth herein shall void any warranty granted by ST for such product.

ST and the ST logo are trademarks of ST. All other product or service names are the property of their respective owners.

Information in this document supersedes and replaces information previously supplied in any prior versions of this document.

© 2019 STMicroelectronics – All rights reserved

Looking for pricing, stock, or lifecycle information?

Click below to explore more details on WIN SOURCE:

- [⊖ View BLUENRG-MSQTR on WIN SOURCE](#)
- [⊖ STMicroelectronics Information](#)

Optimize Your Supply Chain with WIN SOURCE Solutions

- ✓ Global Sourcing Solution
- ✓ Obsolete Management
- ✓ Cost Control Management
- ✓ Shortage Management
- ✓ Alternative Solution
- ✓ Excess Inventory Management