



**THE DATASHEET OF
TLV2541CDGKR**



TLV2541, TLV2542, TLV2545 2.7-V TO 5.5-V, LOW-POWER, 12-BIT, 140/200 KSPS, SERIAL ANALOG-TO-DIGITAL CONVERTERS WITH AUTOPOWER DOWN

SLAS245E – MARCH 2000 – REVISED APRIL 2010

- **Maximum Throughput . . . 140/200 KSPS**
- **Built-In Conversion Clock**
- **INL/DNL: ± 1 LSB Max, SINAD: 72 dB, SFDR: 85 dB, $f_i = 20$ kHz**
- **SPI/DSP-Compatible Serial Interface**
- **Single Supply: 2.7 Vdc to 5.5 Vdc**
- **Rail-to-Rail Analog Input With 500 kHz BW**
- **Three Options Available:**
 - TLV2541: Single Channel Input
 - TLV2542: Dual Channels With Autosweep
 - TLV2545: Single Channel With Pseudo-Differential Input
- **Low Power With Autopower Down**
 - **Operating Current: 1 mA at 2.7 V, 1.5 mA at 5 V**
 - **Autopower Down: 2 μ A at 2.7 V, 5 μ A at 5 V**
- **Small 8-Pin MSOP and SOIC Packages**

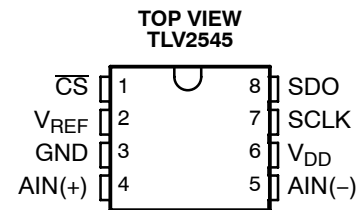
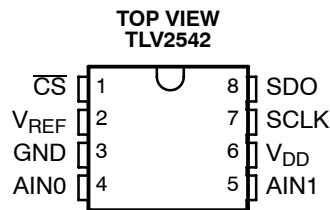
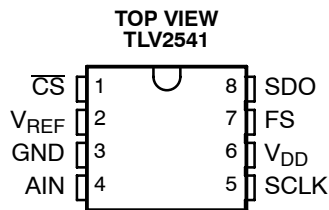

description

The TLV2541, TLV2542, and TLV2545 are a family of high performance, 12-bit, low power, miniature, CMOS analog-to-digital converters (ADC). The TLV254x family operates from a single 2.7-V to 5.5-V supply. Devices are available with single, dual, or single pseudo-differential inputs. Each device has a chip select (\overline{CS}), serial clock (SCLK), and serial data output (SDO) that provides a direct 3-wire interface to the serial port of most popular host microprocessors (SPI interface). When interfaced with a TMS320™ DSP, a frame sync signal (FS) can be used to indicate the start of a serial data frame on \overline{CS} for all devices or FS for the TLV2541.

TLV2541, TLV2542, and TLV2545 are designed to operate with very low power consumption. The power saving feature is further enhanced with an autopower-down mode. This product family features a high-speed serial link to modern host processors with SCLK up to 20 MHz. The maximum SCLK frequency is dependent upon the mode of operation (see Table 1). The TLV254x family uses the built-in oscillator as the conversion clock, providing a 3.5- μ s conversion time.

AVAILABLE OPTIONS

T_A	PACKAGED DEVICES	
	8-MSOP (DGK)	8-SOIC (D)
0°C to 70°C	TLV2541CDGK (AGZ)	
	TLV2542CDGK (AHB)	
	TLV2545CDGK (AHD)	
–40°C to 85°C	TLV2541IDGK (AHA)	TLV2541ID
	TLV2542IDGK (AHC)	TLV2542ID
	TLV2545IDGK (AHE)	TLV2545ID



Please be aware that an important notice concerning availability, standard warranty, and use in critical applications of Texas Instruments semiconductor products and disclaimers thereto appears at the end of this data sheet.

TMS320 is a trademark of Texas Instruments.

PRODUCTION DATA information is current as of publication date. Products conform to specifications per the terms of Texas Instruments standard warranty. Production processing does not necessarily include testing of all parameters.



POST OFFICE BOX 655303 • DALLAS, TEXAS 75265
POST OFFICE BOX 1443 • HOUSTON, TEXAS 77251-1443

Copyright © 2000 – 2003, Texas Instruments Incorporated

TLV2541, TLV2542, TLV2545
2.7-V TO 5.5-V, LOW-POWER, 12-BIT, 140/200 KSPS,
SERIAL ANALOG-TO-DIGITAL CONVERTERS WITH AUTOPOWER DOWN

SLAS245E – MARCH 2000 – REVISED APRIL 2010

functional block diagram

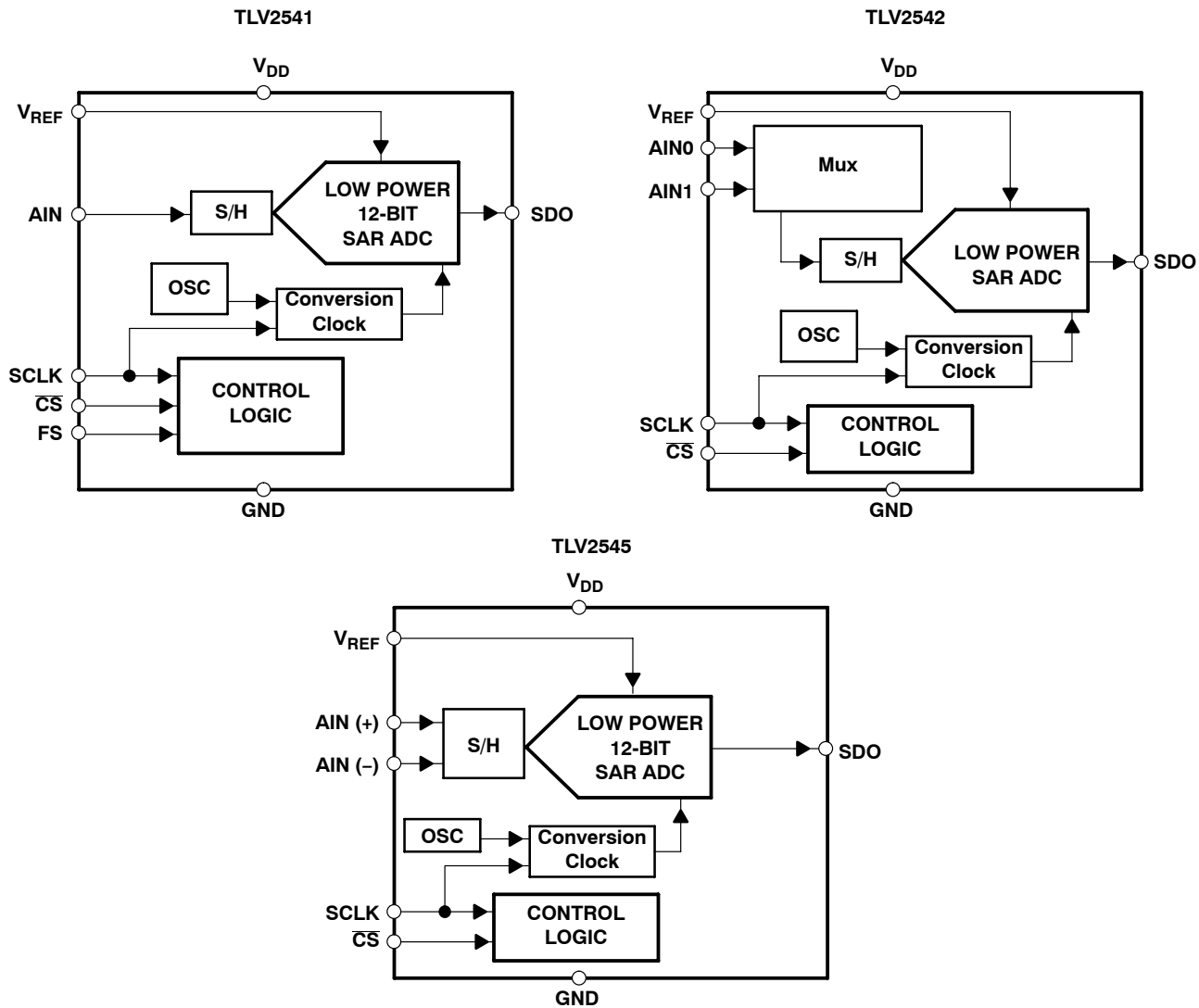

TLV2541, TLV2542, TLV2545
2.7-V TO 5.5-V, LOW-POWER, 12-BIT, 140/200 KSPS,
SERIAL ANALOG-TO-DIGITAL CONVERTERS WITH AUTOPOWER DOWN

SLAS245E –MARCH 2000 – REVISED APRIL 2010

Terminal Functions

TLV2541

TERMINAL		I/O	DESCRIPTION
NAME	NO.		
AIN	4	I	Analog input channel
\overline{CS}	1	I	Chip select. A high-to-low transition on the \overline{CS} input removes SDO from 3-state within a maximum setup time. \overline{CS} can be used as the FS pin when a dedicated DSP serial port is used.
FS	7	I	DSP frame sync input. Indication of the start of a serial data frame. Tie this terminal to V_{DD} if not used.
GND	3	I	Ground return for the internal circuitry. Unless otherwise noted, all voltage measurements are with respect to GND.
SCLK	5	I	Output serial clock. This terminal receives the serial SCLK from the host processor.
SDO	8	O	The 3-state serial output for the A/D conversion result. SDO is kept in the high-impedance state until \overline{CS} falling edge or FS rising edge, whichever occurs first. The output format is MSB first. When FS is not used ($FS = 1$ at the falling edge of \overline{CS}): The MSB is presented to the SDO pin after \overline{CS} falling edge and output data is valid on the first falling edge of SCLK. When \overline{CS} and FS are both used ($FS = 0$ at the falling edge of \overline{CS}): The MSB is presented to the SDO pin after the falling edge of \overline{CS} . When \overline{CS} is tied/held low, the MSB is presented on SDO after the rising FS. Output data is valid on the first falling edge of SCLK. (This is typically used with an active FS from a DSP using a dedicated serial port.)
V_{DD}	6	I	Positive supply voltage
V_{REF}	2	I	External reference input

TLV2542/45

TERMINAL		I/O	DESCRIPTION
NAME	NO.		
AIN0 /AIN(+)	4	I	Analog input channel 0 for TLV2542—Positive input for TLV2545.
AIN1/AIN (-)	5	I	Analog input channel 1 for TLV2542—Inverted input for TLV2545.
\overline{CS}	1	I	Chip select. A high-to-low transition on \overline{CS} removes SDO from 3-state within a maximum delay time. This pin can be connected to the frame sync of a DSP using a dedicated serial port.
GND	3	I	Ground return for the internal circuitry. Unless otherwise noted, all voltage measurements are with respect to GND.
SCLK	7	I	Output serial clock. This terminal receives the serial SCLK from the host processor.
SDO	8	O	The 3-state serial output for the A/D conversion result. SDO is kept in the high-impedance state when \overline{CS} is high and presents output data after the \overline{CS} falling edge until the LSB is presented. The output format is MSB first. SDO returns to the Hi-Z state after the 16th SCLK. Output data is valid on the falling SCLK edge.
V_{DD}	6	I	Positive supply voltage
V_{REF}	2	I	External reference input

detailed description

The TLV2541, TLV2542, and TLV2545 are successive approximation (SAR) ADCs utilizing a charge redistribution DAC. Figure 1 shows a simplified version of the ADC.

The sampling capacitor acquires the signal on AIN during the sampling period. When the conversion process starts, the SAR control logic and charge redistribution DAC are used to add and subtract fixed amounts of charge from the sampling capacitor to bring the comparator into a balanced condition. When the comparator is balanced, the conversion is complete and the ADC output code is generated.



TLV2541, TLV2542, TLV2545
2.7-V TO 5.5-V, LOW-POWER, 12-BIT, 140/200 KSPS,
SERIAL ANALOG-TO-DIGITAL CONVERTERS WITH AUTOPOWER DOWN

SLAS245E –MARCH 2000 – REVISED APRIL 2010

detailed description (continued)

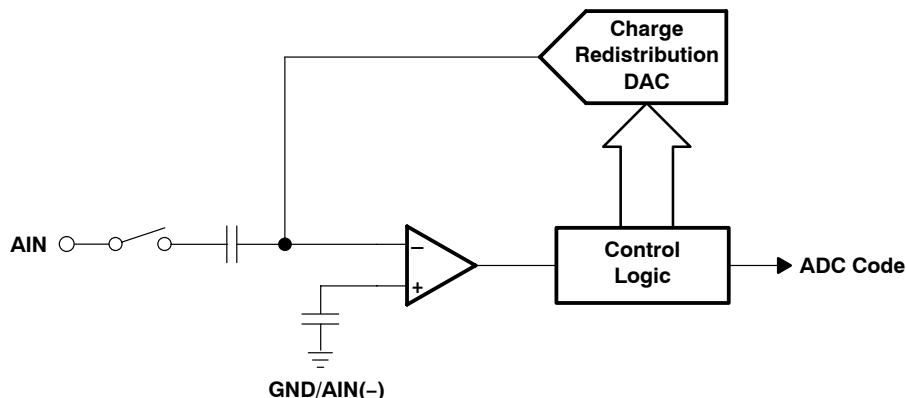

Figure 1. Simplified SAR Circuit

serial interface

OUTPUT DATA FORMAT	
MSB	LSB
D15–D4	D3–D0
Conversion result (OD11–OD0)	Don't care

The output data format is binary (unipolar straight binary).

binary

Zero-scale code = 000h, $V_{code} = GND$
 Full-scale code = FFFh, $V_{code} = V_{REF} - 1 \text{ LSB}$

pseudo-differential inputs

The TLV2545 operates in pseudo-differential mode. The inverted input is available on pin 5. It can have a maximum input ripple of $\pm 0.2 \text{ V}$. This is normally used for ground noise rejection.

control and timing

start of the cycle

Each cycle may be started by either \overline{CS} , FS, or a combination of both. The internal state machine requires one SCLK high-to-low transition to determine the state of these control signals so internal blocks can be powered up in an active cycle. Special care to SPI mode is necessary. Make sure there is at least one SCLK whenever \overline{CS} (pin 1) is high to ensure proper operation.

TLV2541

- Control via \overline{CS} (FS = 1 at the falling edge of \overline{CS})—The falling edge of \overline{CS} is the start of the cycle. The MSB should be read on the first falling SCLK edge after \overline{CS} is low. Output data changes on the rising edge of SCLK. This is typically used for a microcontroller with an SPI interface, although it can also be used for a DSP. The microcontroller SPI interface should be programmed for CPOL = 0 (serial clock referenced to ground) and CPHA = 1 (data is valid on the falling edge of the serial clock). At least one falling edge transition on SCLK is needed whenever \overline{CS} is brought high.
- Control via FS (\overline{CS} is tied/held low)—The MSB is presented after the rising edge of FS. The falling edge of FS is the start of the cycle. The MSB should be read on the first falling edge of SCLK after FS is low. This is the typical configuration when the ADC is the only device on the DSP serial port.



control and timing (continued)

- Control via both \overline{CS} and FS—The MSB is presented after the falling edge of \overline{CS} . The falling edge of FS is the start of the sampling cycle. The MSB should be read on the first falling SCLK edge after FS is low. Output data changes on the rising edge of SCLK. This configuration is typically used for multiple devices connected to a TMS320 DSP.

TLV2542/5

All control is provided using \overline{CS} (pin 1) on the TLV2542 and TLV2545. The cycle is started on the falling edge transition provided by either a \overline{CS} signal from an SPI microcontroller or FS signal from a TMS320 DSP. Timing is similar to the TLV2541, with control via \overline{CS} only.

TLV2542 channel MUX reset cycle

The TLV2542 uses \overline{CS} to reset the analog input multiplexer. A short active \overline{CS} cycle (4 to 7 SCLKs) resets the MUX to AIN0. When the \overline{CS} cycle time is greater than 7 SCLKs in duration, as in the case for a complete conversion cycle (\overline{CS} is low for 16 SCLKs plus maximum conversion time), the MUX toggles to the next channel (see Figure 4 for timing). One dummy conversion cycle is recommended after power up before attempting to reset the MUX.

sampling

The converter sample time is 12 SCLKs in duration, beginning on the fifth SCLK received after the converter has received a high-to-low \overline{CS} transition (or a high-to-low FS transition for the TLV2541).

conversion

The TLV2541, TLV2542, and TLV2545 complete conversions in the following manner. The conversion is started after the 16th SCLK falling edge and takes 3.5 μ s to complete. Enough time (for conversion) should be allowed before a rising \overline{CS} or FS edge so that no conversion is terminated prematurely.

TLV2542 input channel selection is toggled on each rising \overline{CS} edge. The MUX channel can be reset to AIN0 via \overline{CS} as described in the earlier section and in Figure 4. The input is sampled for 12 SCLKs, converted, and the result is presented on SDO during the next cycle. Care should also be taken to allow enough time between samples to avoid prematurely terminating the cycle, which occurs on a rising \overline{CS} transition if the conversion is not complete.

The SDO data presented during a cycle is the result of the conversion of the sample taken during the previous cycle.

timing diagrams/conversion cycles

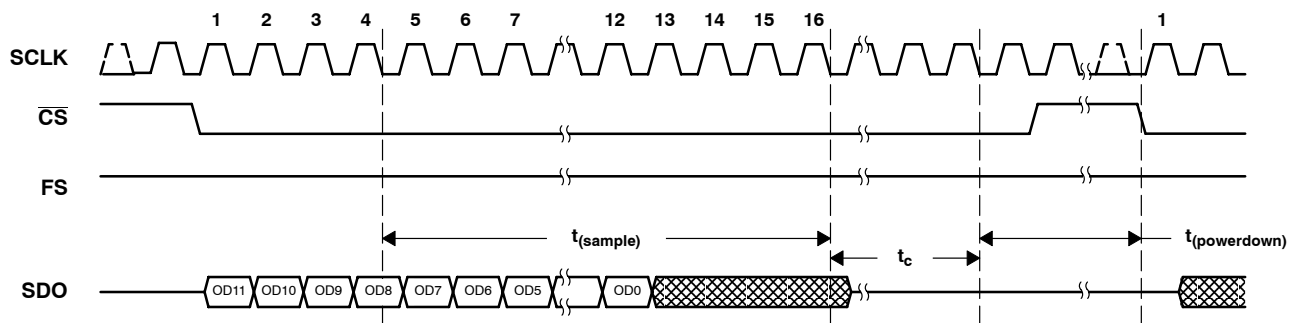

Figure 2. TLV2541 Timing: Control via \overline{CS} (FS = 1)

TLV2541, TLV2542, TLV2545
2.7-V TO 5.5-V, LOW-POWER, 12-BIT, 140/200 KSPS,
SERIAL ANALOG-TO-DIGITAL CONVERTERS WITH AUTOPOWER DOWN

SLAS245E – MARCH 2000 – REVISED APRIL 2010

timing diagrams/conversion cycles (continued)

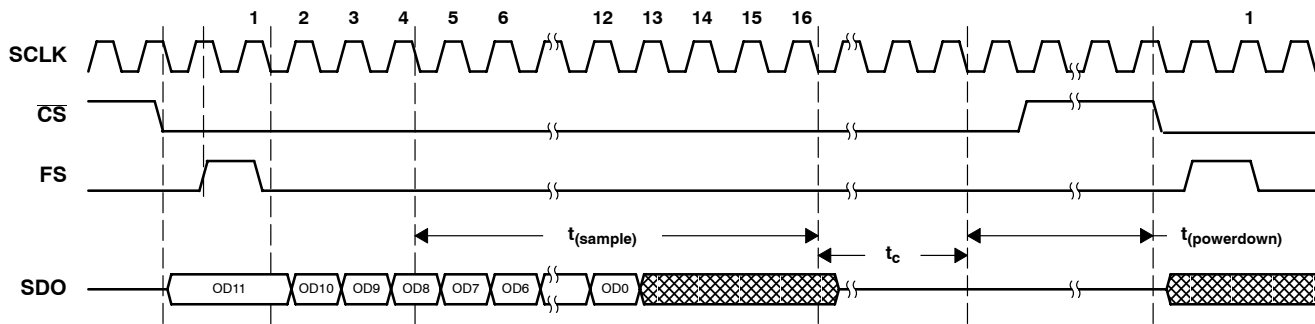

Figure 3. TLV2541 Timing: Control via \overline{CS} and FS or FS Only

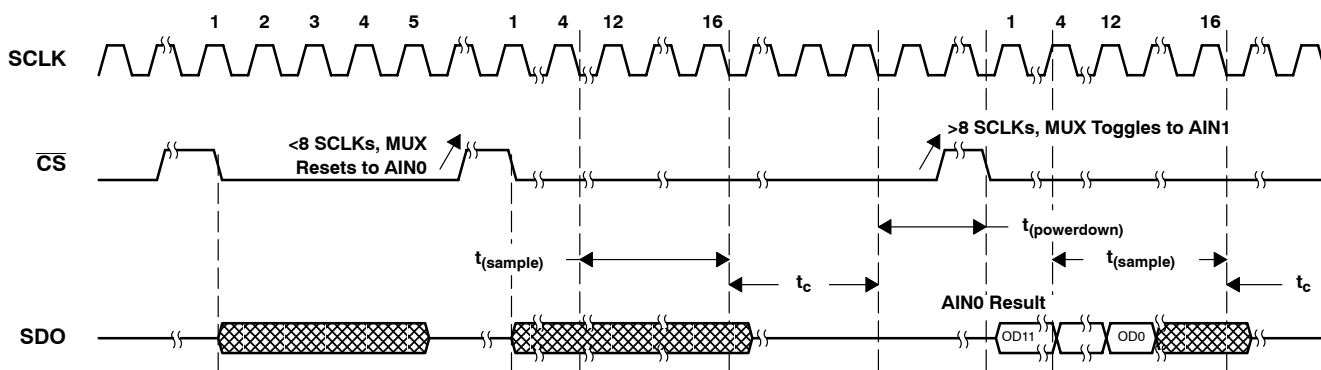

Figure 4. TLV2542 Reset Timing

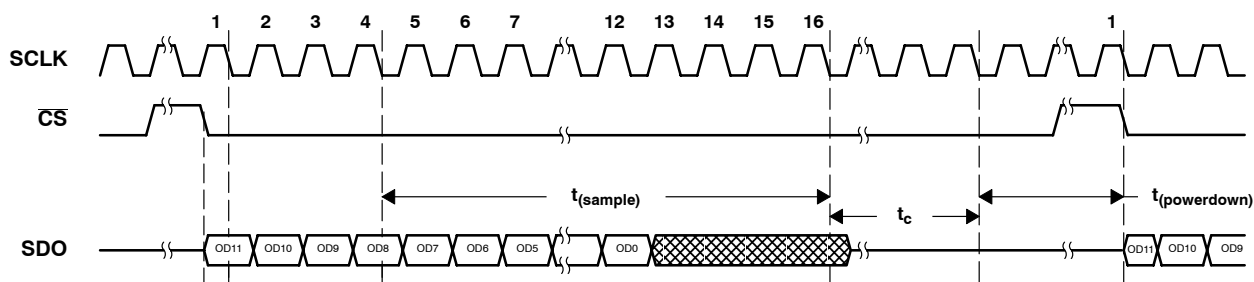

Figure 5. TLV2542 and TLV2545 Timing

using \overline{CS} as the FS input

When interfacing the TLV2541 with the TMS320 DSP, the FSR signal from the DSP may be connected to the \overline{CS} input if this is the only device on the serial port. This saves one output terminal from the DSP. (Output data changes on the falling edge of SCLK. This is the default configuration for the TLV2542 and TLV2545.)



using \overline{CS} as the FS input (continued)

SCLK and conversion speed

The input frequency of SCLK can range from 100 kHz to 20 MHz maximum. The ADC conversion uses a separate internal oscillator with a minimum frequency of 4 MHz. The conversion cycle takes 14 internal oscillator clocks to complete. This leads to a 3.5- μ s conversion time. For a 20-MHz SCLK, the minimum total cycle time is given by: $16 \times (1/20M) + 14 \times (1/4M) + \text{one SCLK} = 4.35 \mu\text{s}$. An additional SCLK is added to account for the required \overline{CS} and/or FS high time. These times specify the minimum cycle time for an active \overline{CS} or FS signal. If violated, the conversion terminates, invalidating the next data output cycle. Table 1 gives the maximum SCLK frequency for a given supply voltage and operational mode.

control via pin 1 (\overline{CS} , SPI interface)

All devices are compatible with this mode operation. A falling \overline{CS} initiates the cycle (for TLV2541, the FS input is tied to V_{DD}). \overline{CS} remains low for the entire cycle time (sample+convert+one SCLK) and can then be released.

NOTE:

IMPORTANT: A single SCLK is required whenever \overline{CS} is high.

control via pin 1 (\overline{CS} , DSP interface)

All devices are compatible with this mode of operation. The FS signal from a DSP is connected directly to the \overline{CS} input of the ADC. A falling edge on the \overline{CS} input initiates the cycle. (For the TLV2541, the FS input can be tied to V_{DD} , although better performance can be achieved when using the FS input for control. Refer to the next section.) The \overline{CS} input should remain low for the entire cycle time (sample+convert+one SCLK) and can then be released.

NOTE:

IMPORTANT: A single SCLK is required whenever \overline{CS} is high. This should be of little consequence, since SCLK is normally always present when interfacing with a DSP.

control via pin 1 and pin 7 (\overline{CS} and FS or FS only, DSP interface)

Only the TLV2541 is compatible with this mode of operation. The \overline{CS} input to the ADC can be controlled via a general-purpose I/O pin from the DSP. The FS signal from the DSP is connected directly to the FS input of the ADC. A falling edge on \overline{CS} , if used, releases the MSB on the SDO output. When \overline{CS} is not used, the rising FS edge releases the MSB. The falling edge on the FS input while SCLK is high initiates the cycle. The \overline{CS} and FS inputs should remain low for the entire cycle time (sample+convert+one SCLK) and can then be released.

reference voltage

An external reference is applied via V_{REF} . The voltage level applied to this pin establishes the upper limit of the analog inputs to produce a full-scale reading. The value of V_{REF} and the analog input should not exceed the positive supply or be less than GND, consistent with the specified absolute maximum ratings. The digital output is at full scale when the input signal is equal to or higher than V_{REF} and at zero when the input signal is equal to or lower than GND.

power down and power up

Autopower down is built into these devices in order to reduce power consumption. The actual power savings depends on the inactive time between cycles and the power supply (loading) decoupling/storage capacitors. *Power-down takes effect immediately after the conversion is complete.* This is fast enough to provide some power savings between cycles with longer than 1 SCLK inactive time. *The device power goes down to 5 μ A within 0.5 μ s.* To achieve the lowest power-down current (*deep powerdown*) of 1 μ A requires 2-ms inactive time between cycles. The power-down state is initiated at the end of conversion. These devices wake up *immediately* at the next falling edge of \overline{CS} or the rising edge of FS.



TLV2541, TLV2542, TLV2545
2.7-V TO 5.5-V, LOW-POWER, 12-BIT, 140/200 KSPS,
SERIAL ANALOG-TO-DIGITAL CONVERTERS WITH AUTOPOWER DOWN

SLAS245E – MARCH 2000 – REVISED APRIL 2010

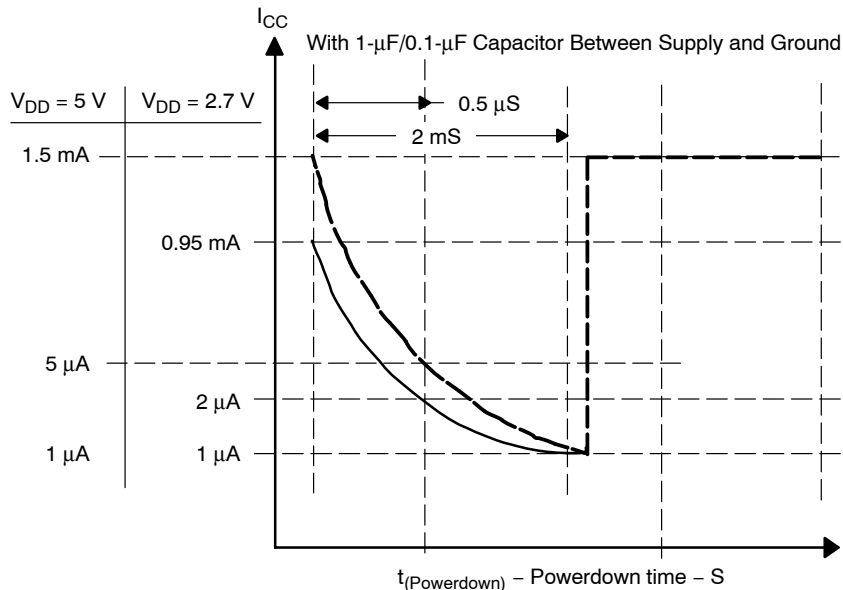

Table 1. Modes of Operation and Data Throughput

CONTROL PIN(S)/DEVICE	MAX SCLK (MHz) (50/50 duty cycle)		APPROXIMATE CONVERSION THROUGHPUT (ksps)	
	V _{DD} = 2.7 V	V _{DD} = 4.5 V	V _{DD} = 2.7 V	V _{DD} = 4.5 V
CS control only (TLV2541 only)				
For SPI interface†	10	15	175	200
For DSP interface (Use CS as FS)‡	5	8	140	175
CS and FS control (TLV2541 only)§				
DSP interface	15	20	200	200

† See Figure 29(a).

‡ See Figure 29(b).

§ See Figure 29(c).

absolute maximum ratings over operating free-air temperature (unless otherwise noted)¶

Supply voltage range, GND to V _{DD}	-0.3 V to 6.5 V
Analog input voltage range	-0.3 V to V _{DD} + 0.3 V
Reference input voltage	V _{DD} + 0.3 V
Digital input voltage range	-0.3 V to V _{DD} + 0.3 V
Operating virtual junction temperature range, T _J	-40°C to 150°C
Operating free-air temperature range, T _A : C	0°C to 70°C
I	-40°C to 85°C
Storage temperature range, T _{stg}	-65°C to 150°C
Lead temperature 1,6 mm (1/16 inch) from case for 10 seconds	260°C

¶ Stresses beyond those listed under “absolute maximum ratings” may cause permanent damage to the device. These are stress ratings only, and functional operation of the device at these or any other conditions beyond those indicated under “recommended operating conditions” is not implied. Exposure to absolute-maximum-rated conditions for extended periods may affect device reliability.



TLV2541, TLV2542, TLV2545
2.7-V TO 5.5-V, LOW-POWER, 12-BIT, 140/200 KSPS,
SERIAL ANALOG-TO-DIGITAL CONVERTERS WITH AUTOPOWER DOWN

SLAS245E – MARCH 2000 – REVISED APRIL 2010

recommended operating conditions

	MIN	NOM	MAX	UNIT	
Supply voltage, V_{DD}	2.7	3.3	5.5	V	
Positive external reference voltage input, V_{REFP} (see Note 1)	2		V_{DD}	V	
Analog input voltage (see Note 1)	0		V_{DD}	V	
High level control input voltage, V_{IH}	2.1			V	
Low-level control input voltage, V_{IL}			0.6	V	
Setup time, \overline{CS} falling edge before first SCLK falling edge, $t_{su}(CSL-SCLKL)$	$V_{DD} = REF = 4.5\text{ V}$	40		ns	
	$V_{DD} = REF = 2.7\text{ V}$	70			
Hold time, \overline{CS} falling edge after SCLK falling edge, $t_h(SCLKL-CSL)$	5			ns	
Delay time, delay from \overline{CS} falling edge to FS rising edge, $t_d(CSL-FSH)$ (TLV2541 only)	0.5		7	SCLKs	
Setup time, FS rising edge before SCLK falling edge, $t_{su}(FSH-SCLKL)$ (TLV2541 only)	0.35			SCLKs	
Hold time, FS high after SCLK falling edge, $t_h(SCLKL-FSL)$ (TLV2541 only)			0.65	SCLKs	
Pulse width \overline{CS} high time, $t_w(H_CS)$	100			ns	
Pulse width FS high time, $t_w(H_FS)$ (TLV2541 only)	0.75			SCLKs	
SCLK cycle time, $V_{DD} = 3.6\text{ V}$ to 2.7 V , $t_c(SCLK)$ (maximum tolerance of 40/60 duty cycle)	90		10000	ns	
SCLK cycle time, $V_{DD} = 5.5\text{ V}$ to 4.5 V , $t_c(SCLK)$ (maximum tolerance of 40/60 duty cycle)	50		10000	ns	
Pulse width low time, $t_w(L_SCLK)$	0.4		0.6	SCLK	
Pulse width high time, $t_w(H_SCLK)$	0.4		0.6	SCLK	
Hold time, hold from end of conversion to \overline{CS} high, $t_h(EOC-CSH)$ (EOC is internal, indicates end of conversion time, t_c)		0.05		μs	
Active \overline{CS} cycle time to reset internal MUX to AIN0, $t_{(reset\ cycle)}$ (TLV2542 only)	4		7	SCLKs	
Delay time, delay from \overline{CS} falling edge to SDO valid, $t_d(CSL-SDOV)$	$V_{DD} = REF = 4.5\text{ V}$, 25-pF load		40	ns	
	$V_{DD} = REF = 2.7\text{ V}$, 25-pF load		70		
Delay time, delay from FS falling edge to SDO valid, $t_d(FSL-SDOV)$ (TLV2541 only)	$V_{DD} = REF = 4.5\text{ V}$, 25-pF load		1	ns	
	$V_{DD} = REF = 2.7\text{ V}$, 25-pF load		1		
Delay time, delay from SCLK rising edge to SDO valid, $t_d(SCLKH-SDOV)$	$V_{DD} = REF = 4.5\text{ V}$, 25-pF load		11	ns	
	$V_{DD} = REF = 2.7\text{ V}$, 25-pF load		21		
Delay time, delay from 17th SCLK rising edge to SDO 3-state, $t_d(SCLK17H-SDOZ)$	$V_{DD} = REF = 4.5\text{ V}$, 25-pF load		30	ns	
	$V_{DD} = REF = 2.7\text{ V}$, 25-pF load		60		
Conversion time, t_c		2.1	2.6	3.5	μs
Sampling time, $t_{(sample)}$	See Note 2	300			ns
Operating free-air temperature, T_A	TLV2541/2/5C	0	70	$^{\circ}\text{C}$	
	TLV2541/2/5I	-40	85		

- NOTES: 1. Analog input voltages greater than that applied to V_{REF} convert as all ones (111111111111), while input voltages less than that applied to GND convert as all zeros(000000000000).
2. Minimal $t_{(sample)}$ is given by $0.9 \times 50\text{ pF} \times (R_S + 0.5\text{ k}\Omega)$, where R_S is the source output impedance.



TLV2541, TLV2542, TLV2545
2.7-V TO 5.5-V, LOW-POWER, 12-BIT, 140/200 KSPS,
SERIAL ANALOG-TO-DIGITAL CONVERTERS WITH AUTOPOWER DOWN

SLAS245E –MARCH 2000 – REVISED APRIL 2010

electrical characteristics over recommended operating free-air temperature range,
 $V_{DD} = V_{REF} = 2.7\text{ V to }5.5\text{ V}$ (unless otherwise noted)

PARAMETER		TEST CONDITIONS	MIN	TYP†	MAX	UNIT
V_{OH}	High-level output voltage	$V_{DD} = 5.5\text{ V}$, $I_{OH} = -0.2\text{ mA}$ at 30-pF load	2.4		$V_{DD}-0.2$	V
		$V_{DD} = 2.7\text{ V}$, $I_{OH} = -20\text{ }\mu\text{A}$ at 30-pF load				
V_{OL}	Low-level output voltage	$V_{DD} = 5.5\text{ V}$, $I_{OL} = 0.8\text{ mA}$ at 30-pF load	0.4			V
		$V_{DD} = 2.7\text{ V}$, $I_{OL} = 20\text{ }\mu\text{A}$ at 30-pF load	0.1			
I_{OZ}	Off-state output current (high-impedance-state)	$V_O = V_{DD}$	$\overline{CS} = V_{DD}$	1	2.5	μA
		$V_O = 0$		-1	-2.5	
I_{IH}	High-level input current	$V_I = V_{DD}$	0.005		2.5	μA
I_{IL}	Low-level input current	$V_I = 0\text{ V}$	-0.005		2.5	μA
I_{CC}	Operating supply current	\overline{CS} at 0 V	$V_{DD} = 4.5\text{ V to }5.5\text{ V}$	1.3	1.5	mA
			$V_{DD} = 2.7\text{ V to }3.3\text{ V}$	0.85	0.95	
$I_{CC(AUTOPWDN)}$	Autopower-down current $t_{(\text{powerdown})} \geq 0.5\text{ }\mu\text{s}$	For all digital inputs, $0 \leq V_I \leq 0.3\text{ V}$ or $V_I \geq V_{DD} - 0.3\text{ V}$, SCLK = 0, $V_{DD} = 4.5\text{ V to }5.5\text{ V}$, Ext ref		5		μA
		$V_{DD} = 2.7\text{ V to }3.3\text{ V}$, Ext ref		2		
	Deep autopower-down current $t_{(\text{powerdown})} \geq 2\text{ ms}$	For all digital inputs, $0 \leq V_I \leq 0.3\text{ V}$ or $V_I \geq V_{DD} - 0.3\text{ V}$, SCLK = 0, $V_{DD} = 4.5\text{ V to }5.5\text{ V}$, Ext ref		1		μA
		$V_{DD} = 2.7\text{ V to }3.3\text{ V}$		1		
Selected analog input channel leakage current		Selected channel at V_{DD}		1		μA
		Selected channel at 0 V		-1		
C_i	Input capacitance	Analog inputs		20	45	pF
		Control Inputs		5		
Input on resistance		$V_{DD} = 5.5\text{ V}$		500		Ω
		$V_{DD} = 2.7\text{ V}$		600		
Autopower down				0.5		SCLK

† All typical values are at $V_{DD} = 5\text{ V}$, $T_A = 25^\circ\text{C}$.



TLV2541, TLV2542, TLV2545
2.7-V TO 5.5-V, LOW-POWER, 12-BIT, 140/200 KSPS,
SERIAL ANALOG-TO-DIGITAL CONVERTERS WITH AUTOPOWER DOWN

SLAS245E –MARCH 2000 – REVISED APRIL 2010

ac specifications ($f_i = 20$ kHz)

PARAMETER		TEST CONDITIONS	MIN	TYP	MAX	UNIT
SINAD	Signal-to-noise ratio +distortion	200 KSPS, $V_{DD} = V_{REF} = 5.5$ V	70	72		dB
		150 KSPS, $V_{DD} = V_{REF} = 2.7$ V	68	71		
THD	Total harmonic distortion	200 KSPS, $V_{DD} = V_{REF} = 5.5$ V		-84	-80	dB
		150 KSPS, $V_{DD} = V_{REF} = 2.7$ V		-84	-80	
ENOB	Effective number of bits	200 KSPS, $V_{DD} = V_{REF} = 5.5$ V		11.8		Bits
		150 KSPS, $V_{DD} = V_{REF} = 2.7$ V		11.6		
SFDR	Spurious free dynamic range	200 KSPS, $V_{DD} = V_{REF} = 5.5$ V		-84	-80	dB
		150 KSPS, $V_{DD} = V_{REF} = 2.7$ V		-84	-80	
Analog Input						
	Full-power bandwidth, -3 dB			1		MHz
	Full-power bandwidth, -1 dB			500		kHz

external reference specifications

PARAMETER		TEST CONDITIONS	MIN	TYP	MAX	UNIT
	Reference input voltage	$V_{DD} = 2.7$ V to 5.5 V	2		V_{DD}	V
Reference input impedance	$V_{DD} = 5.5$ V	$\overline{CS} = 1$, SCLK = 0	100			M Ω
		$\overline{CS} = 0$, SCLK = 20 MHz	20	25		k Ω
	$V_{DD} = 2.7$ V	$\overline{CS} = 1$, SCLK = 0	100			M Ω
		$\overline{CS} = 0$, SCLK = 20 MHz	20	25		k Ω
Reference current	$V_{DD} = V_{REF} = 5.5$ V,	$\overline{CS} = 0$, SCLK = 20 MHz		100	400	μ A
	$V_{DD} = V_{REF} = 2.7$ V,	$\overline{CS} = 0$, SCLK = 20 MHz		50	200	
Reference input capacitance	$V_{DD} = V_{REF} = 5.5$ V	$\overline{CS} = 1$, SCLK = 0	5		15	pF
		$\overline{CS} = 0$, SCLK = 20 MHz	20	45	50	
	$V_{DD} = V_{REF} = 2.7$ V	$\overline{CS} = 1$, SCLK = 0	5		15	
		$\overline{CS} = 0$, SCLK = 20 MHz	20	45	50	
V_{REF}	Reference voltage	$V_{DD} = 2.7$ V to 5.5 V			V_{DD}	V

dc specification, $V_{DD} = V_{REF} = 2.7$ V to 5.5 V, SCLK frequency = 20 MHz at 5 V, 15 MHz at 3 V (unless otherwise noted)

PARAMETER		TEST CONDITIONS	MIN	TYP	MAX	UNIT
INL	Integral linearity error (see Note 4)			± 0.6	± 1	LSB
DNL	Differential linearity error	See Note 3		± 0.5	± 1	LSB
E_O	Offset error (see Note 5)	See Note 3	TLV2541/42		± 1.5	LSB
			TLV2545		± 2.5	
E_G	Gain error (see Note 5)	See Note 3	TLV2541/42		± 2	LSB
			TLV2545		± 5	
E_t	Total unadjusted error (see Note 6)	See Note 3	TLV2541/42		± 2	LSB
			TLV2545		± 5	

- NOTES: 3. Analog input voltages greater than that applied to V_{REF} convert as all ones (111111111111).
4. Linear error is the maximum deviation from the best straight line through the A/D transfer characteristics.
5. Zero error is the difference between 000000000000 and the converted output for zero input voltage: full-scale error is the difference between 111111111111 and the converted output for full-scale input voltage.
6. Total unadjusted error comprises linearity, zero, and full-scale errors.



TLV2541, TLV2542, TLV2545
2.7-V TO 5.5-V, LOW-POWER, 12-BIT, 140/200 KSPS,
SERIAL ANALOG-TO-DIGITAL CONVERTERS WITH AUTOPOWER DOWN
 SLAS245E – MARCH 2000 – REVISED APRIL 2010

PARAMETER MEASUREMENT INFORMATION

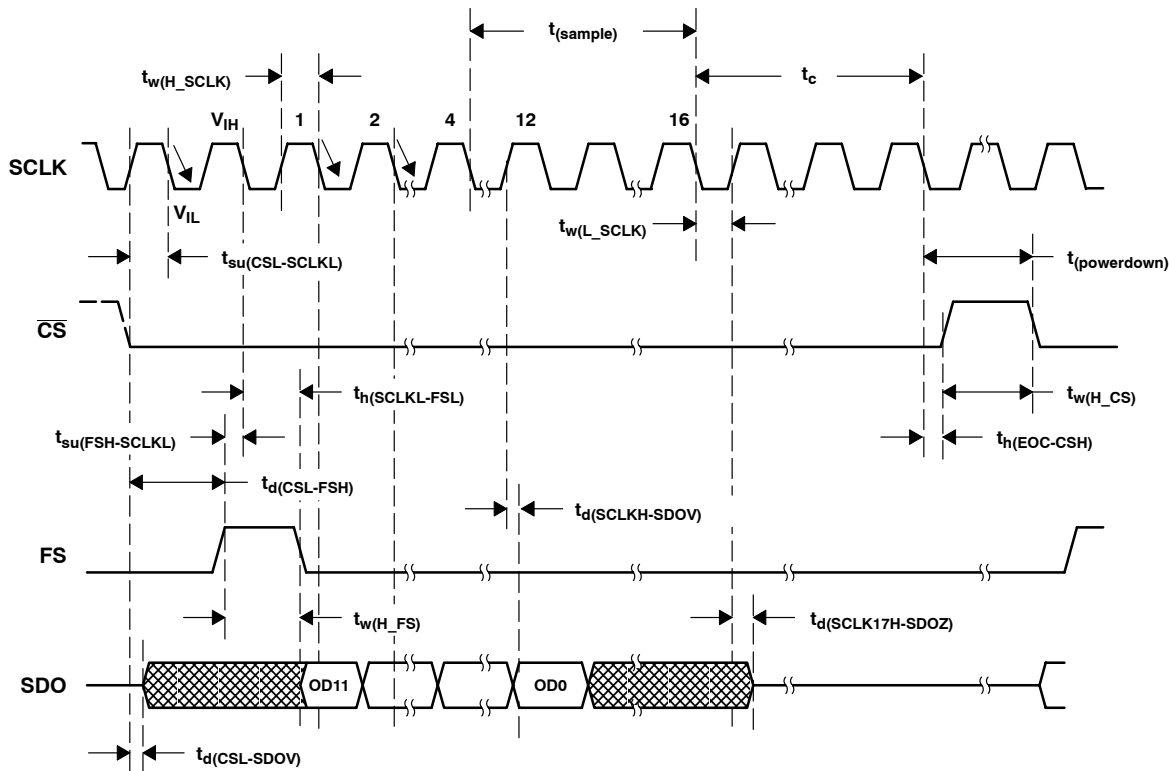

Figure 6. TLV2541 Critical Timing (Control via \overline{CS} and FS or FS only)

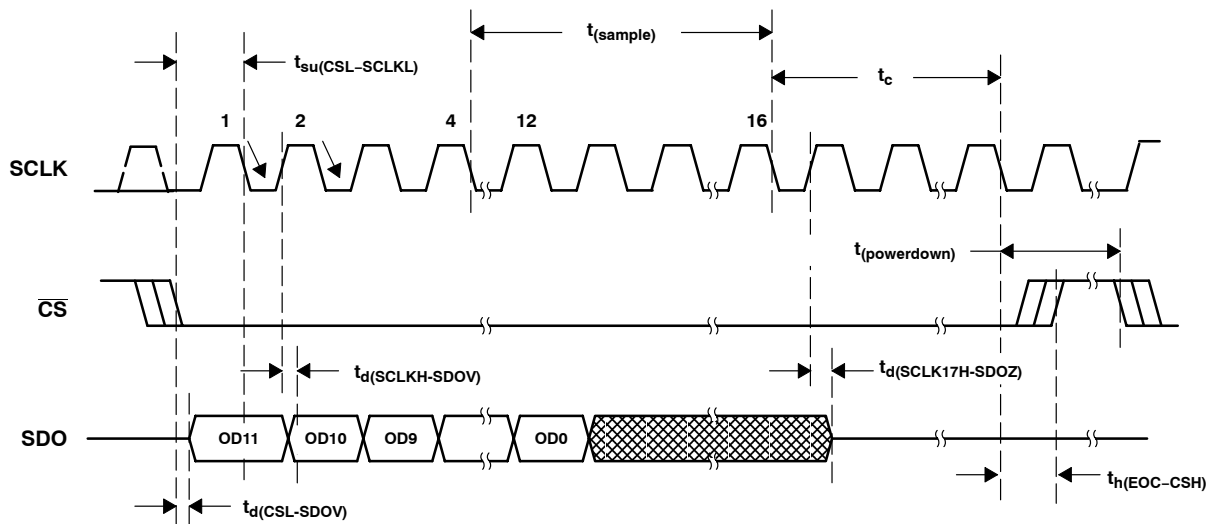

Figure 7. TLV2541 Critical Timing (Control via \overline{CS} only, FS = 1)



TLV2541, TLV2542, TLV2545
2.7-V TO 5.5-V, LOW-POWER, 12-BIT, 140/200 KSPS,
SERIAL ANALOG-TO-DIGITAL CONVERTERS WITH AUTOPOWER DOWN

SLAS245E - MARCH 2000 - REVISED APRIL 2010

PARAMETER MEASUREMENT INFORMATION

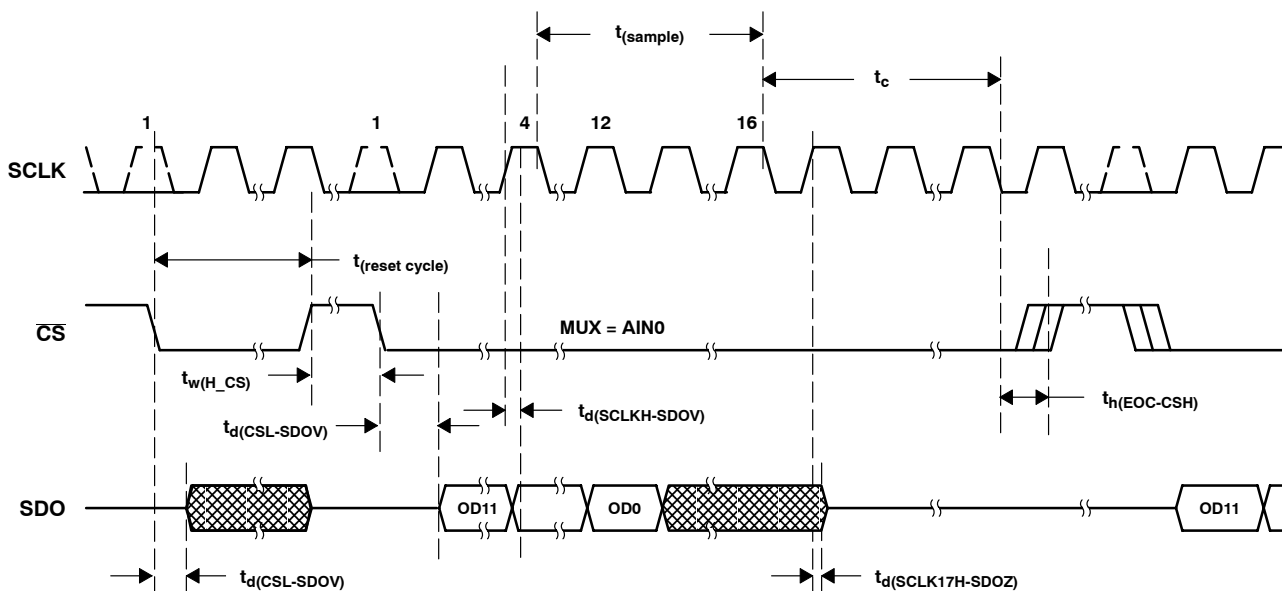

Figure 8. TLV2542 Reset Cycle Critical Timing

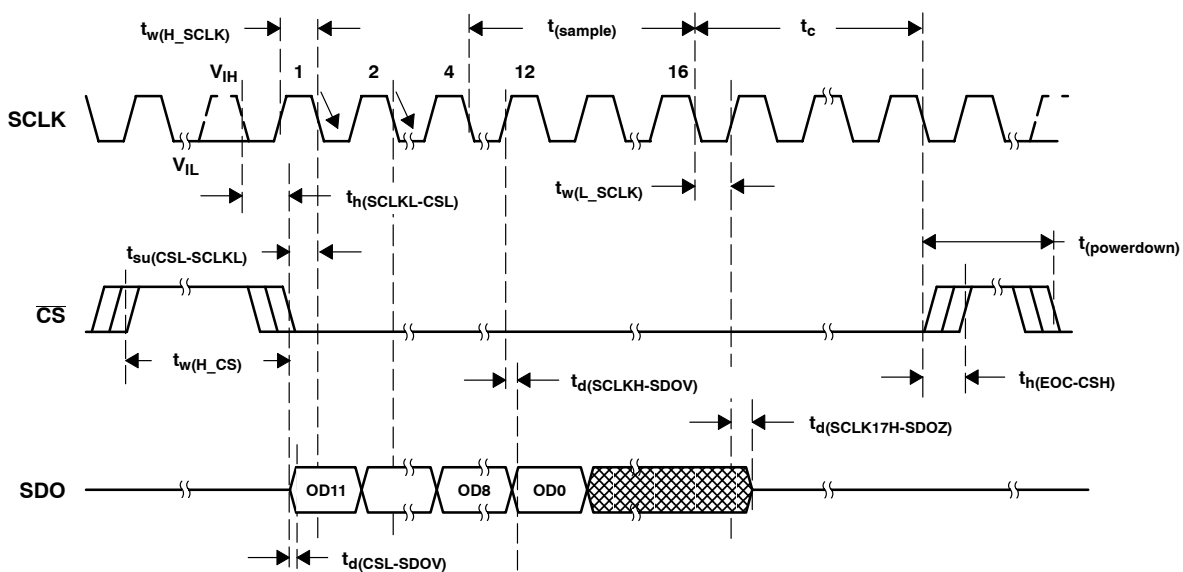

Figure 9. TLV2542 and TLV2545 Conversion Cycle Critical Timing

TLV2541, TLV2542, TLV2545
2.7-V TO 5.5-V, LOW-POWER, 12-BIT, 140/200 KSPS,
SERIAL ANALOG-TO-DIGITAL CONVERTERS WITH AUTOPOWER DOWN

SLAS245E –MARCH 2000 – REVISED APRIL 2010

TYPICAL CHARACTERISTICS

INTEGRAL NONLINEARITY
vs
FREE-AIR TEMPERATURE

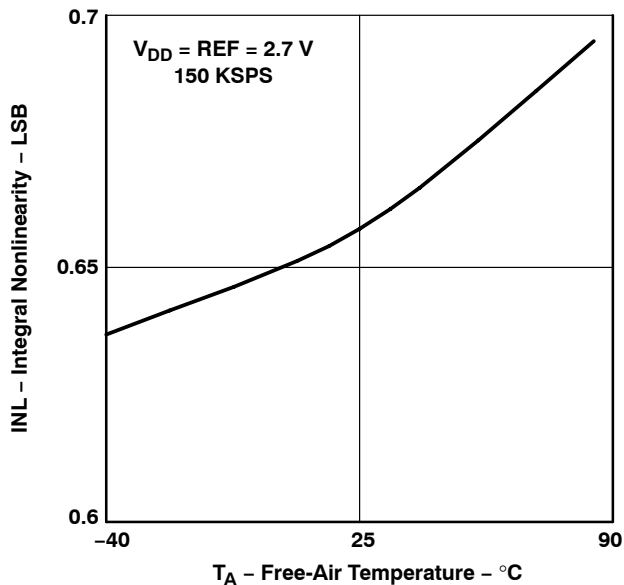

Figure 10

INTEGRAL NONLINEARITY
vs
FREE-AIR TEMPERATURE

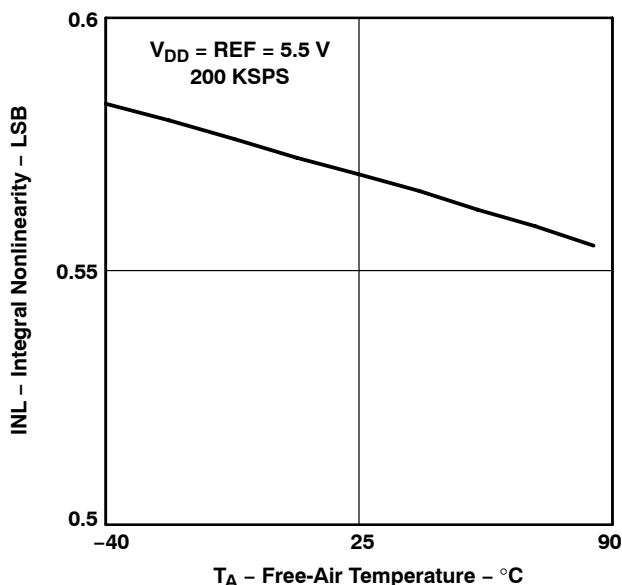

Figure 11

DIFFERENTIAL NONLINEARITY
vs
FREE-AIR TEMPERATURE

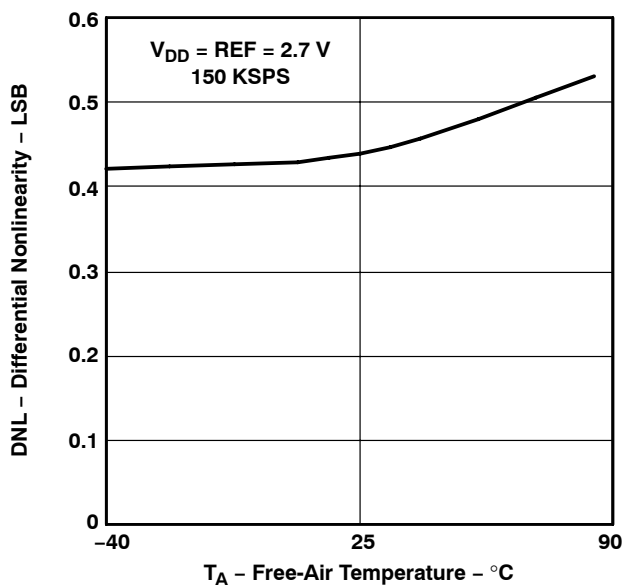

Figure 12

DIFFERENTIAL NONLINEARITY
vs
FREE-AIR TEMPERATURE

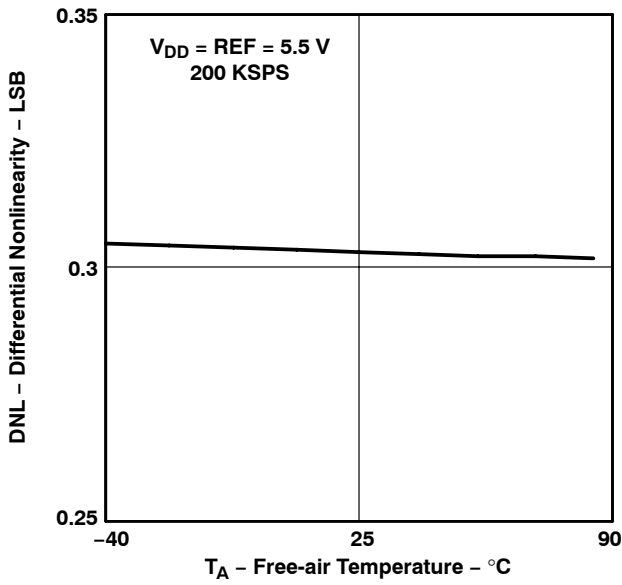

Figure 13



TYPICAL CHARACTERISTICS

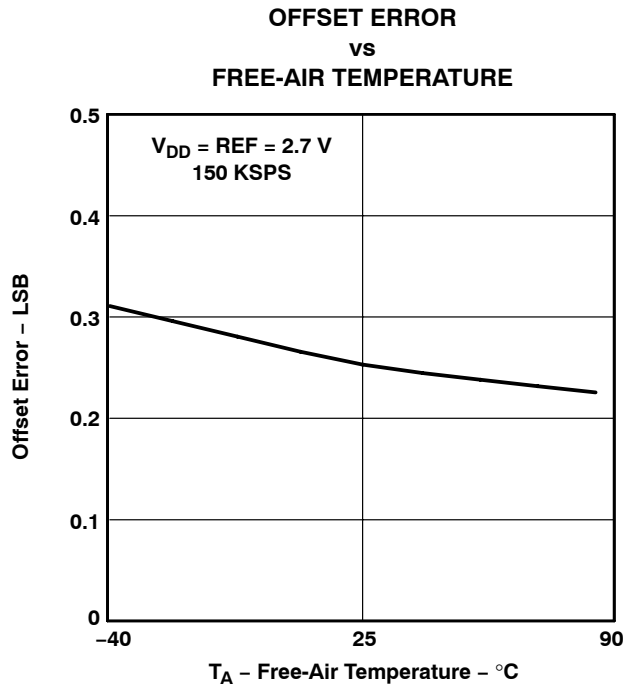

Figure 14

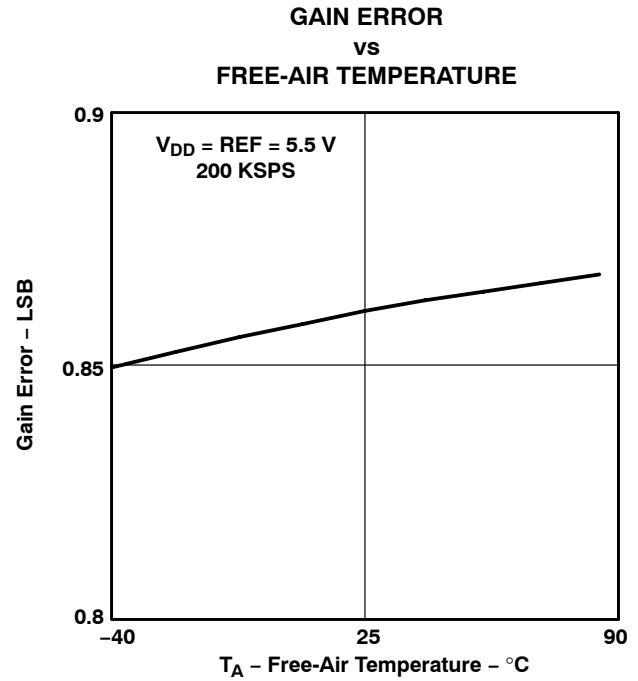

Figure 15

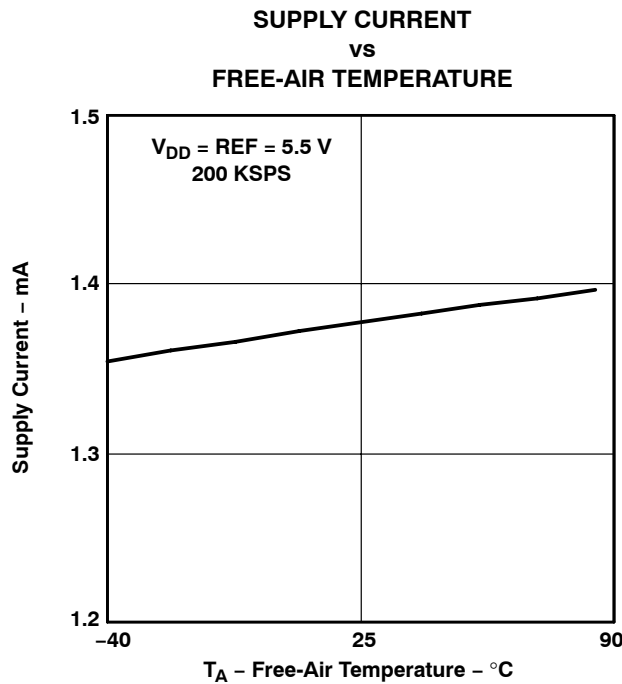

Figure 16

TYPICAL CHARACTERISTICS

INTEGRAL NONLINEARITY ERROR
vs
DIGITAL OUTPUT CODES

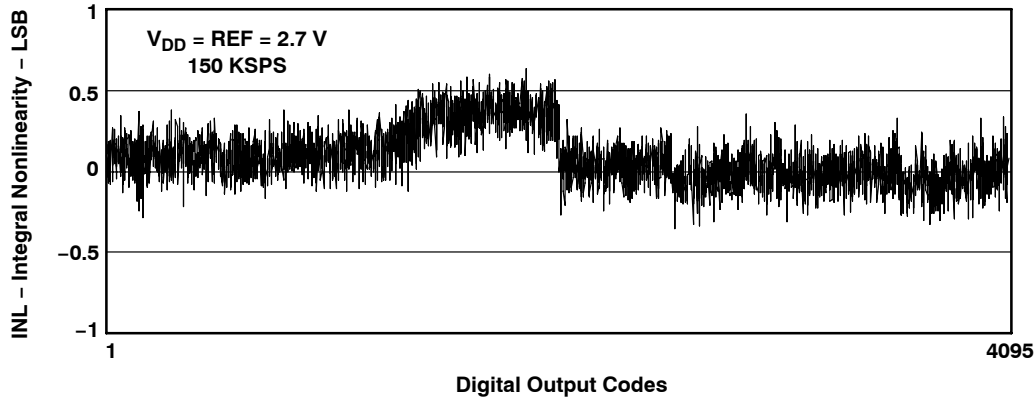

Figure 17

DIFFERENTIAL NONLINEARITY ERROR
vs
DIGITAL OUTPUT CODES

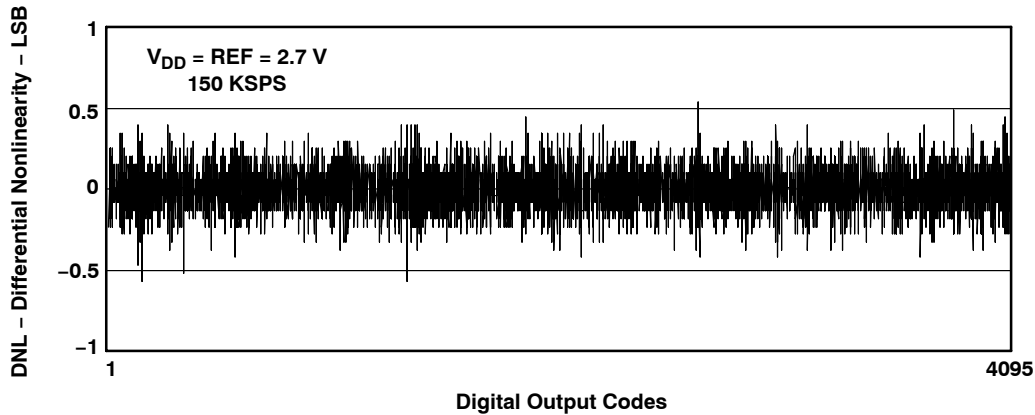

Figure 18

TYPICAL CHARACTERISTICS

INTEGRAL NONLINEARITY ERROR
vs
DIGITAL OUTPUT CODES

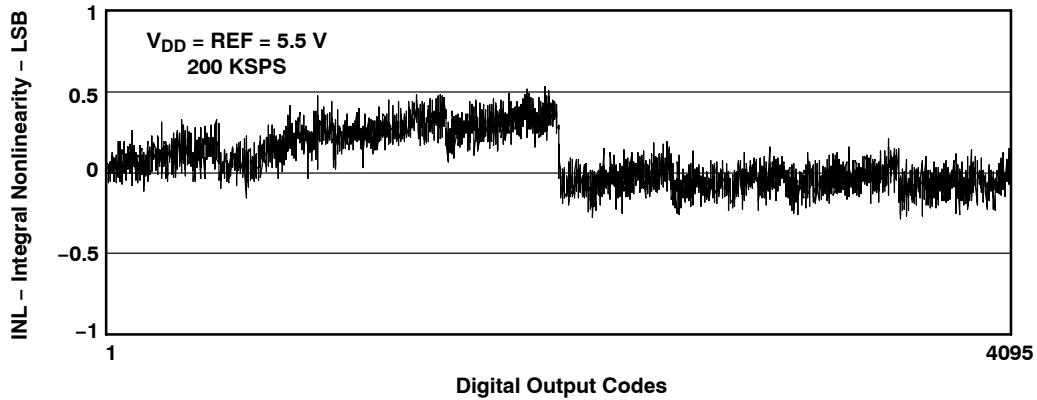

Figure 19

DIFFERENTIAL NONLINEARITY ERROR
vs
DIGITAL OUTPUT CODES

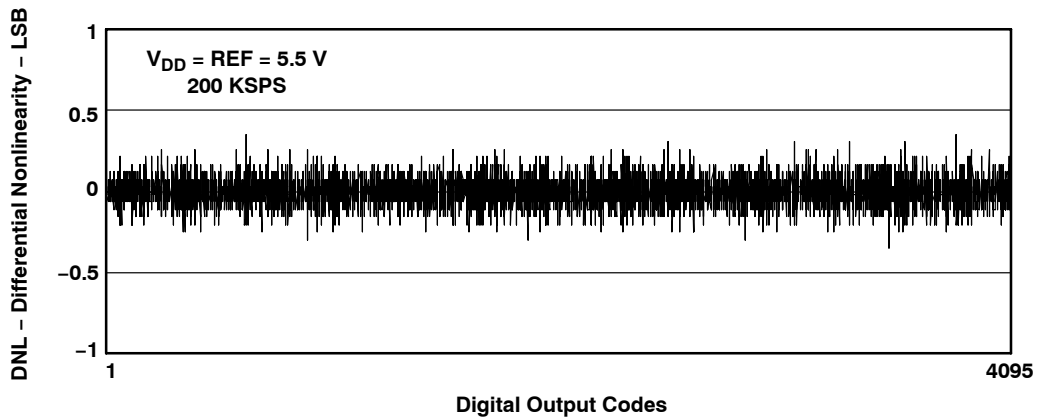

Figure 20

TYPICAL CHARACTERISTICS

2048 POINTS FAST FOURIER TRANSFORM (FFT)

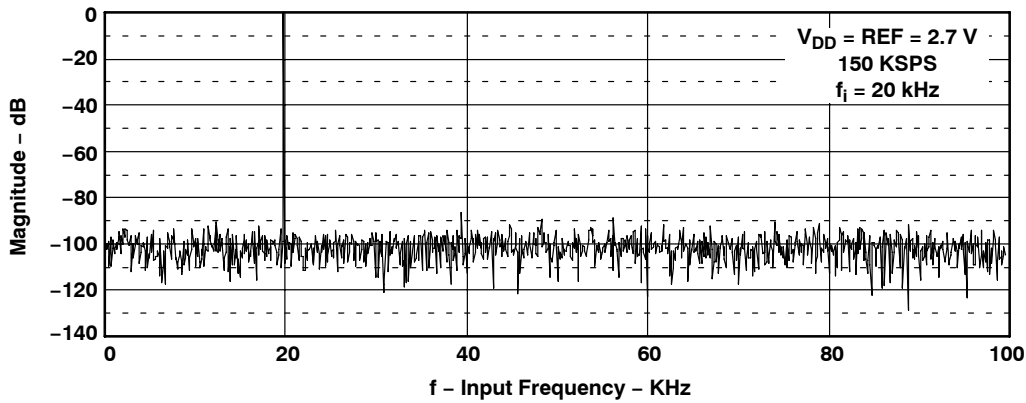

Figure 21

2048 POINTS FAST FOURIER TRANSFORM (FFT)

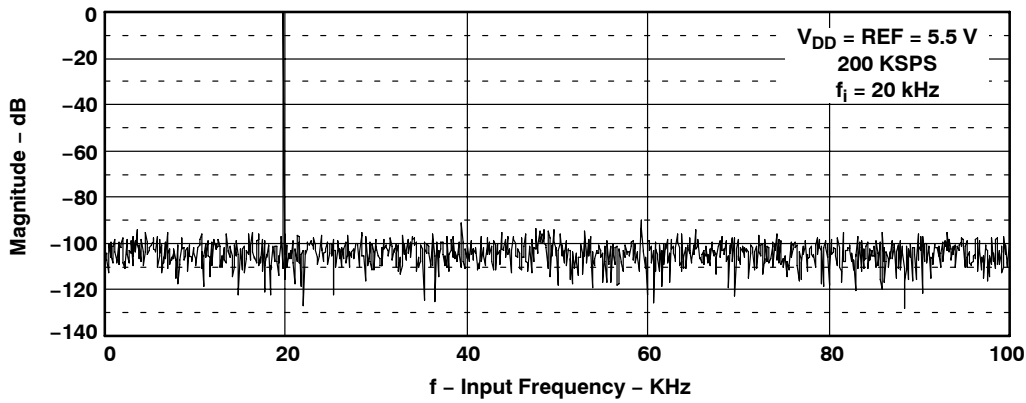

Figure 22



TLV2541, TLV2542, TLV2545
2.7-V TO 5.5-V, LOW-POWER, 12-BIT, 140/200 KSPS,
SERIAL ANALOG-TO-DIGITAL CONVERTERS WITH AUTOPOWER DOWN

SLAS245E – MARCH 2000 – REVISED APRIL 2010

TYPICAL CHARACTERISTICS

SIGNAL-TO-NOISE + DISTORTION
vs
INPUT FREQUENCY

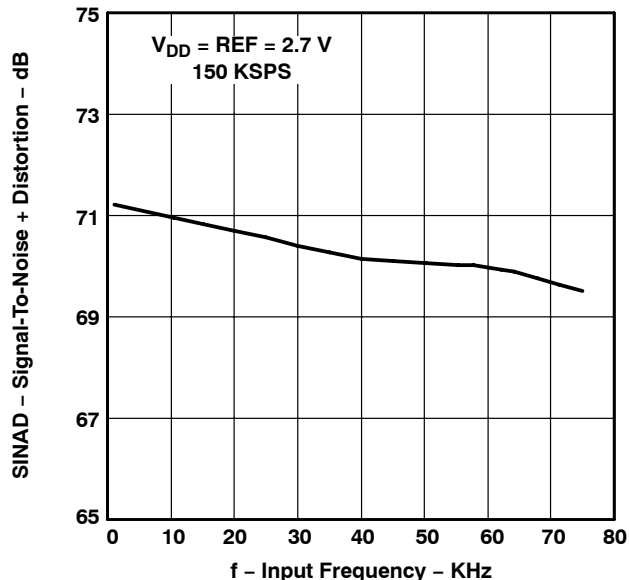

Figure 23

SIGNAL-TO-NOISE + DISTORTION
vs
INPUT FREQUENCY

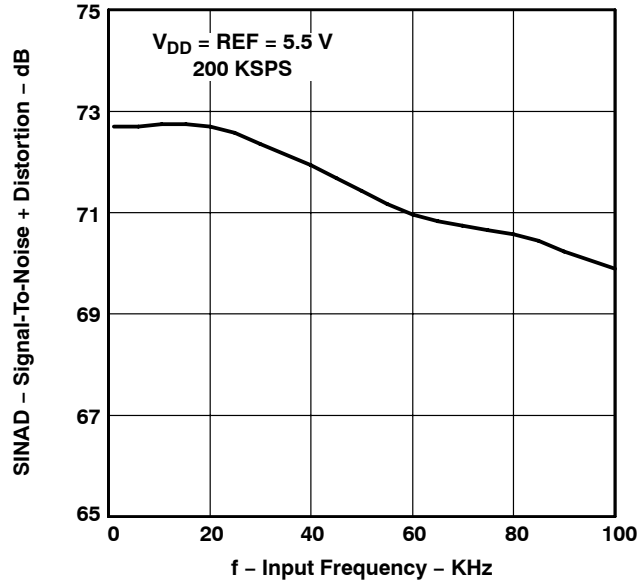

Figure 24

EFFECTIVE NUMBER OF BITS
vs
INPUT FREQUENCY

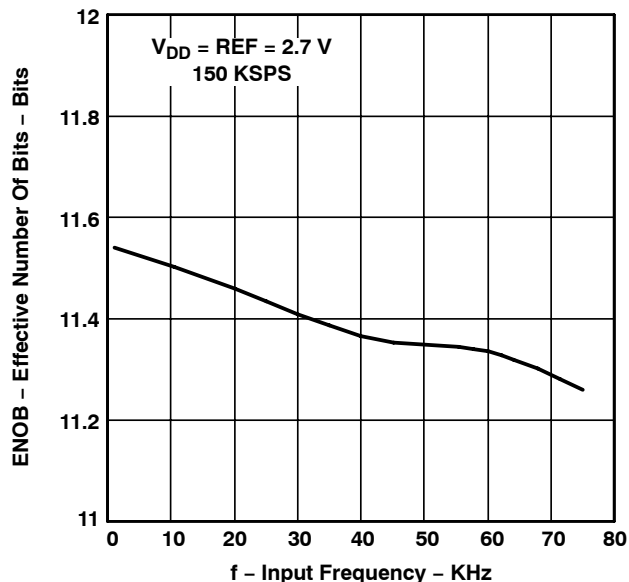

Figure 25

EFFECTIVE NUMBER OF BITS
vs
INPUT FREQUENCY

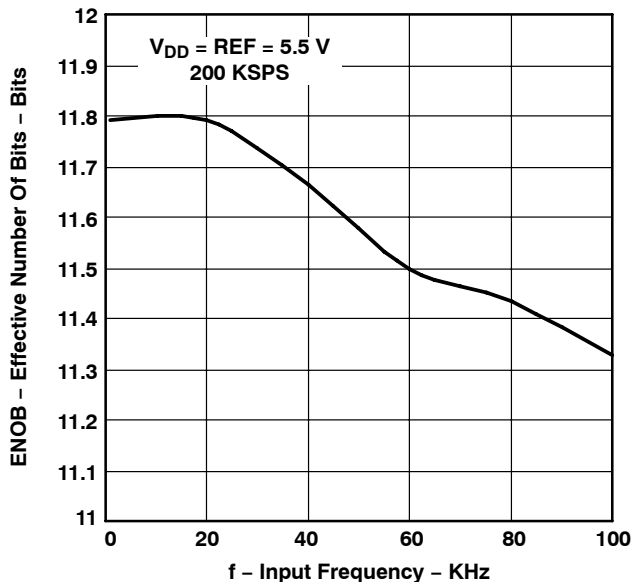

Figure 26



TYPICAL CHARACTERISTICS

**TOTAL HARMONIC DISTORTION
 vs
 INPUT FREQUENCY**

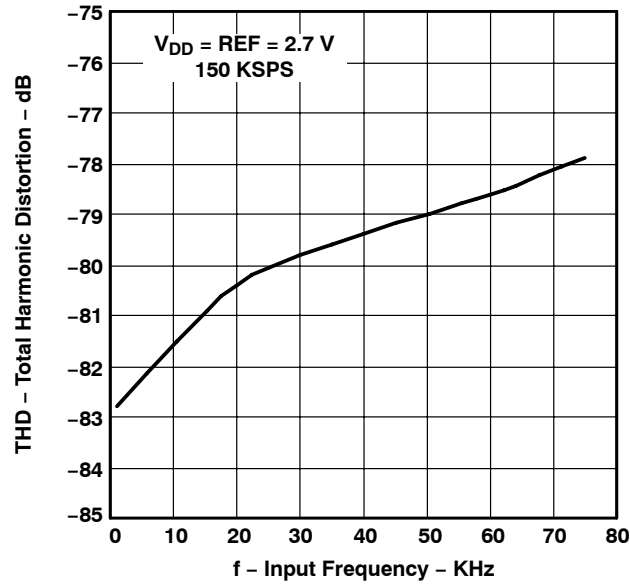

Figure 27

**TOTAL HARMONIC DISTORTION
 vs
 INPUT FREQUENCY**

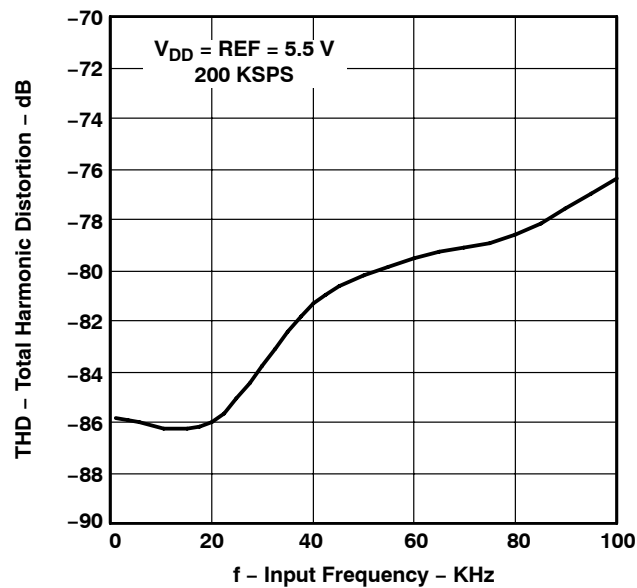

Figure 28



TLV2541, TLV2542, TLV2545
2.7-V TO 5.5-V, LOW-POWER, 12-BIT, 140/200 KSPS,
SERIAL ANALOG-TO-DIGITAL CONVERTERS WITH AUTOPOWER DOWN

SLAS245E –MARCH 2000 – REVISED APRIL 2010

APPLICATION INFORMATION

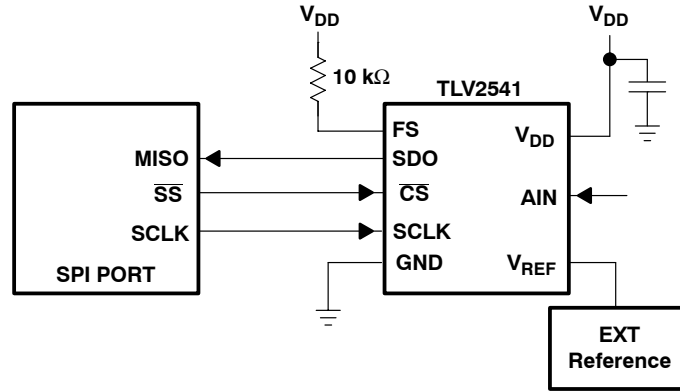

(a)

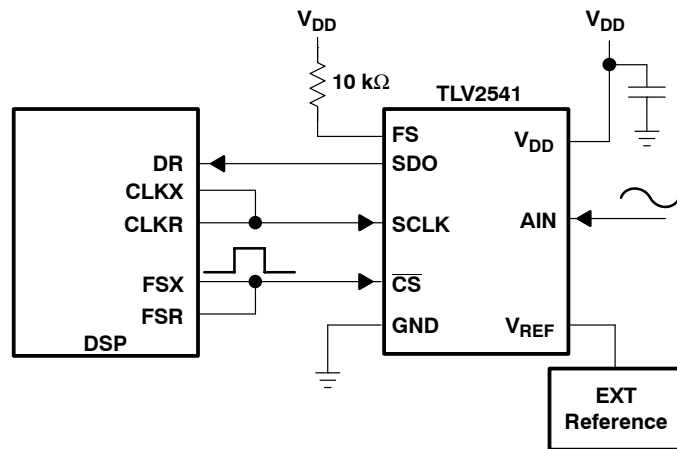

(b)

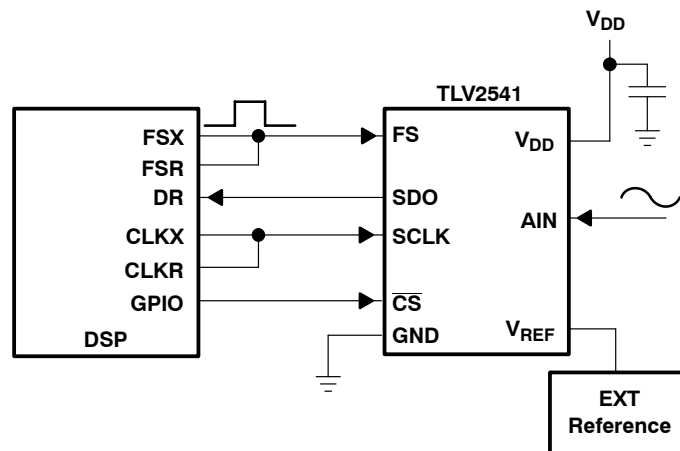

(c)

Figure 29. Typical TLV2541 Interface to a TMS320 DSP

TLV2541, TLV2542, TLV2545
2.7-V TO 5.5-V, LOW-POWER, 12-BIT, 140/200 KSPS,
SERIAL ANALOG-TO-DIGITAL CONVERTERS WITH AUTOPOWER DOWN
 SLAS245E -MARCH 2000 - REVISED APRIL 2010

APPLICATION INFORMATION

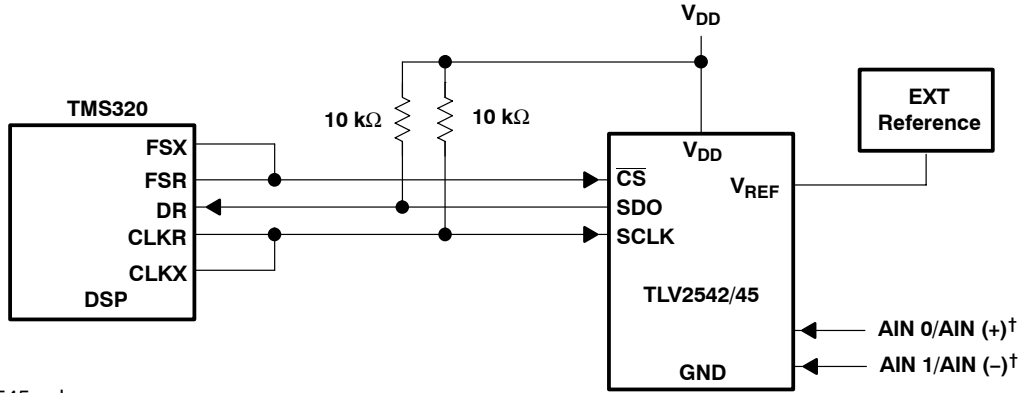

† For TLV2545 only

Figure 30. Typical TLV2542/45 Interface to a TMS320 DSP

PACKAGING INFORMATION

Orderable Device	Status (1)	Package Type	Package Drawing	Pins	Package Qty	Eco Plan (2)	Lead/Ball Finish (6)	MSL Peak Temp (3)	Op Temp (°C)	Device Marking (4/5)	Samples
TLV2541CDGK	ACTIVE	VSSOP	DGK	8	80	Green (RoHS & no Sb/Br)	CU NIPDAUAG	Level-1-260C-UNLIM	0 to 70	AGZ	Samples
TLV2541CDGKR	ACTIVE	VSSOP	DGK	8	2500	Green (RoHS & no Sb/Br)	CU NIPDAUAG	Level-1-260C-UNLIM	0 to 70	AGZ	Samples
TLV2541ID	ACTIVE	SOIC	D	8	75	Green (RoHS & no Sb/Br)	CU NIPDAU	Level-1-260C-UNLIM	-40 to 85	2541I	Samples
TLV2541IDG4	ACTIVE	SOIC	D	8	75	Green (RoHS & no Sb/Br)	CU NIPDAU	Level-1-260C-UNLIM	-40 to 85	2541I	Samples
TLV2541IDGK	ACTIVE	VSSOP	DGK	8	80	Green (RoHS & no Sb/Br)	CU NIPDAUAG	Level-1-260C-UNLIM	-40 to 85	AHA	Samples
TLV2541IDGKR	ACTIVE	VSSOP	DGK	8	2500	Green (RoHS & no Sb/Br)	CU NIPDAUAG	Level-1-260C-UNLIM	-40 to 85	AHA	Samples
TLV2541IDR	ACTIVE	SOIC	D	8	2500	Green (RoHS & no Sb/Br)	CU NIPDAU	Level-1-260C-UNLIM	-40 to 85	2541I	Samples
TLV2542CDGK	ACTIVE	VSSOP	DGK	8	80	Green (RoHS & no Sb/Br)	CU NIPDAUAG	Level-1-260C-UNLIM	0 to 70	AHB	Samples
TLV2542CDGKR	ACTIVE	VSSOP	DGK	8	2500	Green (RoHS & no Sb/Br)	CU NIPDAUAG	Level-1-260C-UNLIM	0 to 70	AHB	Samples
TLV2542ID	ACTIVE	SOIC	D	8	75	Green (RoHS & no Sb/Br)	CU NIPDAU	Level-1-260C-UNLIM	-40 to 85	2542I	Samples
TLV2542IDGK	ACTIVE	VSSOP	DGK	8	80	Green (RoHS & no Sb/Br)	CU NIPDAUAG	Level-1-260C-UNLIM	-40 to 85	AHC	Samples
TLV2542IDGKR	ACTIVE	VSSOP	DGK	8	2500	Green (RoHS & no Sb/Br)	CU NIPDAUAG	Level-1-260C-UNLIM	-40 to 85	AHC	Samples
TLV2542IDR	ACTIVE	SOIC	D	8	2500	Green (RoHS & no Sb/Br)	CU NIPDAU	Level-1-260C-UNLIM	-40 to 85	2542I	Samples
TLV2545CDGK	ACTIVE	VSSOP	DGK	8	80	Green (RoHS & no Sb/Br)	CU NIPDAUAG	Level-1-260C-UNLIM	0 to 70	AHD	Samples
TLV2545ID	ACTIVE	SOIC	D	8	75	Green (RoHS & no Sb/Br)	CU NIPDAU	Level-1-260C-UNLIM	-40 to 85	2545I	Samples
TLV2545IDGK	ACTIVE	VSSOP	DGK	8	80	Green (RoHS & no Sb/Br)	CU NIPDAUAG	Level-1-260C-UNLIM	-40 to 85	AHE	Samples

(1) The marketing status values are defined as follows:
ACTIVE: Product device recommended for new designs.

LIFEBUY: TI has announced that the device will be discontinued, and a lifetime-buy period is in effect.

NRND: Not recommended for new designs. Device is in production to support existing customers, but TI does not recommend using this part in a new design.

PREVIEW: Device has been announced but is not in production. Samples may or may not be available.

OBSOLETE: TI has discontinued the production of the device.

⁽²⁾ **RoHS:** TI defines "RoHS" to mean semiconductor products that are compliant with the current EU RoHS requirements for all 10 RoHS substances, including the requirement that RoHS substance do not exceed 0.1% by weight in homogeneous materials. Where designed to be soldered at high temperatures, "RoHS" products are suitable for use in specified lead-free processes. TI may reference these types of products as "Pb-Free".

RoHS Exempt: TI defines "RoHS Exempt" to mean products that contain lead but are compliant with EU RoHS pursuant to a specific EU RoHS exemption.

Green: TI defines "Green" to mean the content of Chlorine (Cl) and Bromine (Br) based flame retardants meet JS709B low halogen requirements of ≤ 1000 ppm threshold. Antimony trioxide based flame retardants must also meet the ≤ 1000 ppm threshold requirement.

⁽³⁾ MSL, Peak Temp. - The Moisture Sensitivity Level rating according to the JEDEC industry standard classifications, and peak solder temperature.

⁽⁴⁾ There may be additional marking, which relates to the logo, the lot trace code information, or the environmental category on the device.

⁽⁵⁾ Multiple Device Markings will be inside parentheses. Only one Device Marking contained in parentheses and separated by a "~" will appear on a device. If a line is indented then it is a continuation of the previous line and the two combined represent the entire Device Marking for that device.

⁽⁶⁾ Lead/Ball Finish - Orderable Devices may have multiple material finish options. Finish options are separated by a vertical ruled line. Lead/Ball Finish values may wrap to two lines if the finish value exceeds the maximum column width.

Important Information and Disclaimer: The information provided on this page represents TI's knowledge and belief as of the date that it is provided. TI bases its knowledge and belief on information provided by third parties, and makes no representation or warranty as to the accuracy of such information. Efforts are underway to better integrate information from third parties. TI has taken and continues to take reasonable steps to provide representative and accurate information but may not have conducted destructive testing or chemical analysis on incoming materials and chemicals. TI and TI suppliers consider certain information to be proprietary, and thus CAS numbers and other limited information may not be available for release.

In no event shall TI's liability arising out of such information exceed the total purchase price of the TI part(s) at issue in this document sold by TI to Customer on an annual basis.

TAPE AND REEL INFORMATION



QUADRANT ASSIGNMENTS FOR PIN 1 ORIENTATION IN TAPE



*All dimensions are nominal

Device	Package Type	Package Drawing	Pins	SPQ	Reel Diameter (mm)	Reel Width W1 (mm)	A0 (mm)	B0 (mm)	K0 (mm)	P1 (mm)	W (mm)	Pin1 Quadrant
TLV2541CDGKR	VSSOP	DGK	8	2500	330.0	12.4	5.3	3.4	1.4	8.0	12.0	Q1
TLV2541IDGKR	VSSOP	DGK	8	2500	330.0	12.4	5.3	3.4	1.4	8.0	12.0	Q1
TLV2541IDR	SOIC	D	8	2500	330.0	12.4	6.4	5.2	2.1	8.0	12.0	Q1
TLV2542CDGKR	VSSOP	DGK	8	2500	330.0	12.4	5.3	3.4	1.4	8.0	12.0	Q1
TLV2542IDGKR	VSSOP	DGK	8	2500	330.0	12.4	5.3	3.4	1.4	8.0	12.0	Q1
TLV2542IDR	SOIC	D	8	2500	330.0	12.4	6.4	5.2	2.1	8.0	12.0	Q1

TAPE AND REEL BOX DIMENSIONS

*All dimensions are nominal

Device	Package Type	Package Drawing	Pins	SPQ	Length (mm)	Width (mm)	Height (mm)
TLV2541CDGKR	VSSOP	DGK	8	2500	350.0	350.0	43.0
TLV2541IDGKR	VSSOP	DGK	8	2500	350.0	350.0	43.0
TLV2541IDR	SOIC	D	8	2500	350.0	350.0	43.0
TLV2542CDGKR	VSSOP	DGK	8	2500	350.0	350.0	43.0
TLV2542IDGKR	VSSOP	DGK	8	2500	350.0	350.0	43.0
TLV2542IDR	SOIC	D	8	2500	350.0	350.0	43.0



D0008A

PACKAGE OUTLINE

SOIC - 1.75 mm max height

SMALL OUTLINE INTEGRATED CIRCUIT



4214825/C 02/2019

NOTES:

- Linear dimensions are in inches [millimeters]. Dimensions in parenthesis are for reference only. Controlling dimensions are in inches. Dimensioning and tolerancing per ASME Y14.5M.
- This drawing is subject to change without notice.
- This dimension does not include mold flash, protrusions, or gate burrs. Mold flash, protrusions, or gate burrs shall not exceed $.006$ [0.15] per side.
- This dimension does not include interlead flash.
- Reference JEDEC registration MS-012, variation AA.

EXAMPLE BOARD LAYOUT

D0008A

SOIC - 1.75 mm max height

SMALL OUTLINE INTEGRATED CIRCUIT



LAND PATTERN EXAMPLE
 EXPOSED METAL SHOWN
 SCALE:8X



SOLDER MASK DETAILS

4214825/C 02/2019

NOTES: (continued)

- 6. Publication IPC-7351 may have alternate designs.
- 7. Solder mask tolerances between and around signal pads can vary based on board fabrication site.

EXAMPLE STENCIL DESIGN

D0008A

SOIC - 1.75 mm max height

SMALL OUTLINE INTEGRATED CIRCUIT



SOLDER PASTE EXAMPLE
BASED ON .005 INCH [0.125 MM] THICK STENCIL
SCALE:8X

4214825/C 02/2019

NOTES: (continued)

8. Laser cutting apertures with trapezoidal walls and rounded corners may offer better paste release. IPC-7525 may have alternate design recommendations.
9. Board assembly site may have different recommendations for stencil design.



- NOTES:
- A. All linear dimensions are in millimeters.
 - B. This drawing is subject to change without notice.
 - C. Publication IPC-7351 is recommended for alternate designs.
 - D. Laser cutting apertures with trapezoidal walls and also rounding corners will offer better paste release. Customers should contact their board assembly site for stencil design recommendations. Refer to IPC-7525 for other stencil recommendations.
 - E. Customers should contact their board fabrication site for solder mask tolerances between and around signal pads.

IMPORTANT NOTICE AND DISCLAIMER

TI PROVIDES TECHNICAL AND RELIABILITY DATA (INCLUDING DATASHEETS), DESIGN RESOURCES (INCLUDING REFERENCE DESIGNS), APPLICATION OR OTHER DESIGN ADVICE, WEB TOOLS, SAFETY INFORMATION, AND OTHER RESOURCES "AS IS" AND WITH ALL FAULTS, AND DISCLAIMS ALL WARRANTIES, EXPRESS AND IMPLIED, INCLUDING WITHOUT LIMITATION ANY IMPLIED WARRANTIES OF MERCHANTABILITY, FITNESS FOR A PARTICULAR PURPOSE OR NON-INFRINGEMENT OF THIRD PARTY INTELLECTUAL PROPERTY RIGHTS.

These resources are intended for skilled developers designing with TI products. You are solely responsible for (1) selecting the appropriate TI products for your application, (2) designing, validating and testing your application, and (3) ensuring your application meets applicable standards, and any other safety, security, or other requirements. These resources are subject to change without notice. TI grants you permission to use these resources only for development of an application that uses the TI products described in the resource. Other reproduction and display of these resources is prohibited. No license is granted to any other TI intellectual property right or to any third party intellectual property right. TI disclaims responsibility for, and you will fully indemnify TI and its representatives against, any claims, damages, costs, losses, and liabilities arising out of your use of these resources.

TI's products are provided subject to TI's Terms of Sale (www.ti.com/legal/termsofsale.html) or other applicable terms available either on ti.com or provided in conjunction with such TI products. TI's provision of these resources does not expand or otherwise alter TI's applicable warranties or warranty disclaimers for TI products.

Mailing Address: Texas Instruments, Post Office Box 655303, Dallas, Texas 75265
Copyright © 2019, Texas Instruments Incorporated

Looking for pricing, stock, or lifecycle information?

Click below to explore more details on WIN SOURCE:

 [View TLV2541CDGKR on WIN SOURCE](#)

 [Texas Instruments](#) Information

Optimize Your Supply Chain with WIN SOURCE Solutions

-  Global Sourcing Solution
-  Obsolete Management
-  Cost Control Management
-  Shortage Management
-  Alternative Solution
-  Excess Inventory Management