



THE DATASHEET OF DG541DJ



Wideband/Video "T" Switches

DESCRIPTION

The DG540, DG541, DG542 are high performance monolithic wideband/video switches designed for switching RF, video and digital signals. By utilizing a "T" switch configuration on each channel, these devices achieve exceptionally low crosstalk and high off-isolation. The crosstalk and off-isolation of the DG540 are further improved by the introduction of extra GND pins between signal pins. To achieve TTL compatibility, low channel capacitances and fast switching times, the DG540 family is built on the Vishay Siliconix proprietary D/CMOS process. Each switch conducts equally well in both directions when on.

FEATURES

- Halogen-free according to IEC 61249-2-21 Definition
- Wide Bandwidth: 500 MHz
- Low Crosstalk: - 85 dB
- High Off-Isolation: - 80 dB at 5 MHz
- "T" Switch Configuration
- TTL and CMOS Logic Compatible
- Fast Switching - t_{ON} : 45 ns
- Low $R_{DS(on)}$: 30 Ω
- Compliant to RoHS Directive 2002/95/EC



RoHS
COMPLIANT
HALOGEN
FREE

BENEFITS

- Flat Frequency Response
- High Color Fidelity
- Low Insertion Loss
- Improved System Performance
- Reduced Board Space
- Reduced Power Consumption
- Improved Data Throughput

APPLICATIONS

- RF and Video Switching
- RGB Switching
- Local and Wide Area Networks
- Video Routing
- Fast Data Acquisition
- ATE
- Radar/FLR Systems
- Video Multiplexing

FUNCTIONAL BLOCK DIAGRAM AND PIN CONFIGURATION

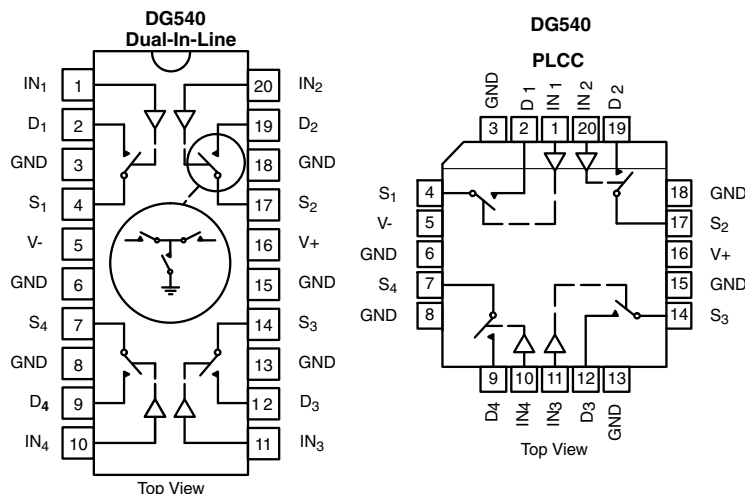

TRUTH TABLE

Logic	Switch
0	OFF
1	ON

Logic "0" ≤ 0.8 V

Logic "1" ≥ 2 V

FUNCTIONAL BLOCK DIAGRAM AND PIN CONFIGURATION

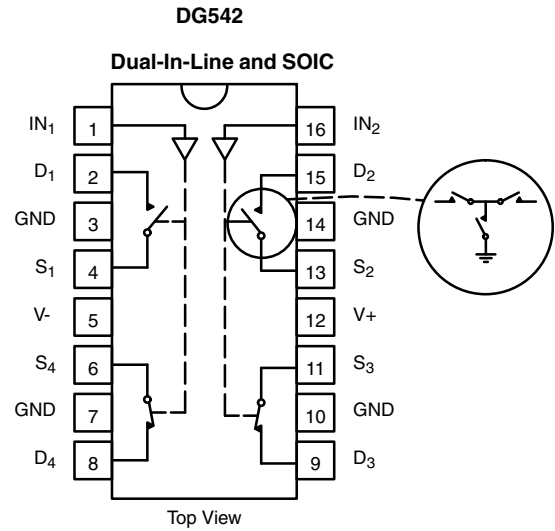
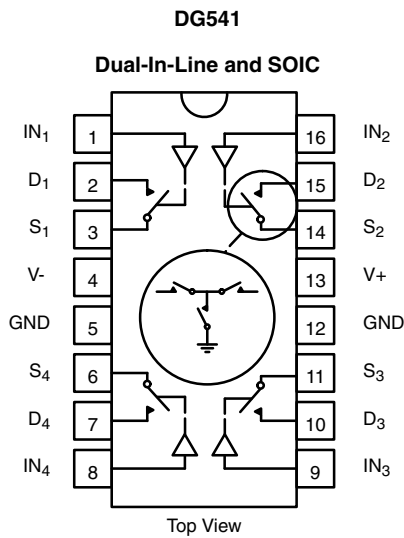

TRUTH TABLE - DG541	
Logic	Switch
0	OFF
1	ON

Logic "0" ≤ 0.8 V
 Logic "1" ≥ 2 V

TRUTH TABLE - DG542		
Logic	SW ₁ , SW ₂	SW ₃ , SW ₄
0	OFF	ON
1	ON	OFF

Logic "0" ≤ 0.8 V
 Logic "1" ≥ 2 V

ORDERING INFORMATION		
Temp Range	Package	Part Number
DG540		
- 40 to 85 °C	20-Pin Plastic DIP	DG540DJ-E3
	20-Pin PLCC	DG540DN-E3
- 55 to 125 °C	20-Pin Sidebrazed	DG540AP
		DG540AP/883
DG541		
- 40 to 85 °C	16-Pin Plastic DIP	DG541DJ-E3
	16-Pin Narrow SOIC	DG541DY-T1-E3
- 55 to 125 °C	16-Pin Sidebrazed	DG541AP
		DG541AP/883, 5962-9076401MEA
DG542		
- 40 to 85 °C	16-Pin Plastic DIP	DG542DJ-E3
	16-Pin Narrow SOIC	DG542DY-T1-E3
- 55 to 125 °C	16-Pin Sidebrazed	DG542AP
		DG542AP/883, 5962-91555201MEA

ABSOLUTE MAXIMUM RATINGS ($T_A = 25\text{ }^\circ\text{C}$, unless otherwise noted)				
Parameter		Symbol	Limit	Unit
V+ to V-			- 0.3 to 21	V
V+ to GND			- 0.3 to 21	
V- to GND			- 19 to + 0.3	
Digital Inputs			(V-) - 0.3 to (V+) + 0.3 or 20 mA, whichever occurs first	
V_S, V_D			(V-) - 0.3 to (V+) + 14 or 20 mA, whichever occurs first	
Continuous Current (Any Terminal)			20	mA
Current, S or D (Pulsed at 1 ms, 10 % duty cycle max)			40	
Storage Temperature	(AP Suffix)		- 65 to 150	$^\circ\text{C}$
	(DJ, DN, DY Suffixes)		- 65 to 125	
Power Dissipation (Package) ^a	16-Pin Plastic DIP ^b		470	mW
	20-Pin Plastic DIP ^c		800	
	16-Pin Narrow Body SOIC ^d		640	
	20-Pin PLCC ^d		800	
	16-, 20-Pin Sidebrazed DIP ^e		900	

Notes:

- All leads welded or soldered to PC Board.
- Derate 6.5 mW/ $^\circ\text{C}$ above 25 $^\circ\text{C}$.
- Derate 7 mW/ $^\circ\text{C}$ above 25 $^\circ\text{C}$.
- Derate 10 mW/ $^\circ\text{C}$ above 75 $^\circ\text{C}$.
- Derate 12 mW/ $^\circ\text{C}$ above 75 $^\circ\text{C}$.

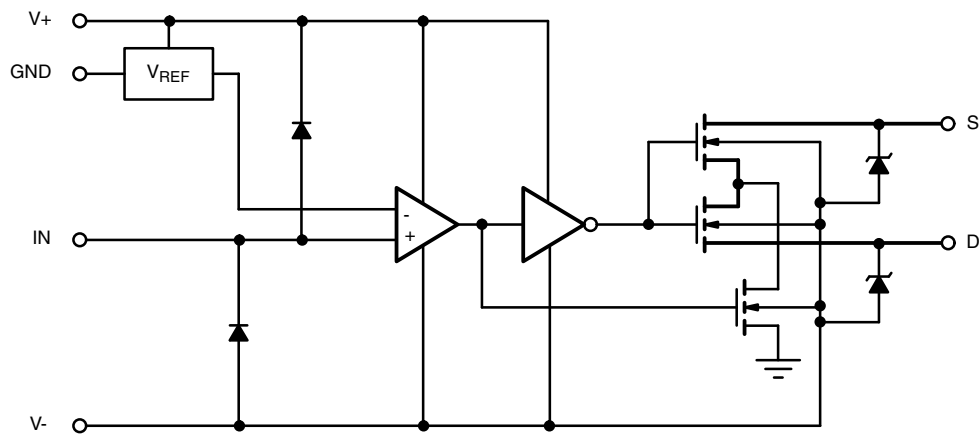
SCHEMATIC DIAGRAM (typical channel)

Figure 1.

SPECIFICATIONS ^a										
Parameter	Symbol	Test Conditions Unless Specified V ₊ = 15 V, V ₋ = - 3 V V _{INH} = 2 V, V _{INL} = 0.8 V ^f	Temp. ^b	Typ. ^c	A Suffix - 55 °C to 125 °C		D Suffixes - 40 °C to 85 °C		Unit	
					Min. ^d	Max. ^d	Min. ^d	Max. ^d		
Analog Switch										
Analog Signal Range	V _{ANALOG}	V ₋ = - 5 V, V ₊ = 12	Full		- 5	5	- 5	5	V	
Drain-Source On-Resistance	R _{D_{S(on)}}	I _S = - 10 mA, V _D = 0 V	Room	30		60		60	Ω	
R _{D_{S(on)}} Match	ΔR _{D_{S(on)}}		Full		100		75			
Source Off Leakage Current	I _{S(off)}	V _S = 0 V, V _D = 10 V	Room	- 0.05	- 10	10	- 10	10	nA	
Drain Off Leakage Current	I _{D(off)}	V _S = 10 V, V _D = 0 V	Full		- 500	500	- 100	100		
Channel On Leakage Current	I _{D(on)}	V _S = V _D = 0 V	Full		- 10	10	- 10	10		
Digital Control										
Input Voltage High	V _{INH}		Full		2		2		V	
Input Voltage Low	V _{INL}		Full			0.8		0.8		
Input Current	I _{IN}	V _{IN} = GND or V ₊	Room	0.05	- 1	1	- 1	1	μA	
			Full		- 20	20	- 20	20		
Dynamic Characteristics										
On State Input Capacitance ^e	C _{S(on)}	V _S = V _D = 0 V	Room	14		20		20	pF	
Off State Input Capacitance ^e	C _{S(off)}	V _S = 0 V	Room	2		4		4		
Off State Output Capacitance ^e	C _{D(off)}	V _D = 0 V	Room	2		4		4		
Bandwidth	BW	R _L = 50 Ω, See Figure 5	Room	500					MHz	
Turn-On Time	t _{ON}	R _L = 1 kΩ C _L = 35 pF 50 % to 90 % See Figure 2	DG540	Room	45		70		70	ns
			DG541	Full			130		130	
Turn-Off Time	t _{OFF}		DG542	Room	55		100		100	
			DG541	Full			160		160	
Charge Injection	Q	C _L = 1000 pF, V _S = 0 V See Figure 3	DG540	Room	- 25				pC	
			DG541	Full						
Off Isolation	OIRR	R _{IN} = 75 Ω, R _L = 75 Ω f = 5 MHz See Figure 4	DG540	Room	- 80				dB	
			DG541	Room	- 60					
			DG542	Room	- 75					
All Hostile Crosstalk	X _{TALK(AH)}	R _{IN} = 10 Ω, R _L = 75 Ω f = 5 MHz, See Figure 6	Room	- 85						
Power Supplies										
Positive Supply Current	I ₊	All Channels On or Off	Room	3.5		6		6	mA	
Negative Supply Current	I ₋		Full		- 3.2	- 6		- 6		
			Full		- 9		- 9			

Notes:

- a. Refer to PROCESS OPTION FLOWCHART .
- b. Room = 25 °C, full = as determined by the operating temperature suffix.
- c. Typical values are for DESIGN AID ONLY, not guaranteed nor subject to production testing.
- d. The algebraic convention whereby the most negative value is a minimum and the most positive a maximum, is used in this data sheet.
- e. Guaranteed by design, not subject to production test.
- f. V_{IN} = input voltage to perform proper function.

Stresses beyond those listed under "Absolute Maximum Ratings" may cause permanent damage to the device. These are stress ratings only, and functional operation of the device at these or any other conditions beyond those indicated in the operational sections of the specifications is not implied. Exposure to absolute maximum rating conditions for extended periods may affect device reliability.

TYPICAL CHARACTERISTICS ($T_A = 25\text{ }^\circ\text{C}$, unless otherwise noted)

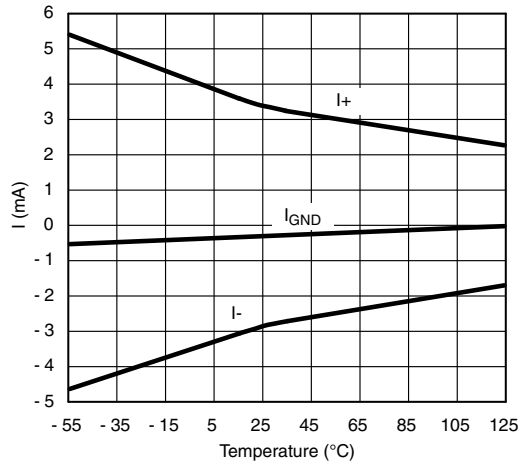

Supply Current vs. Temperature

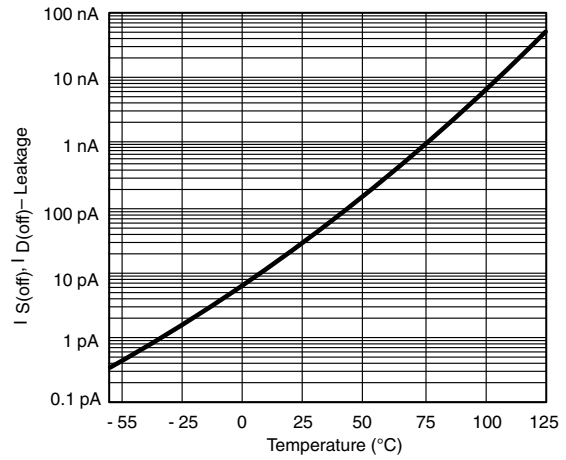

$I_{D(off)}$, $I_{S(off)}$ vs. Temperature

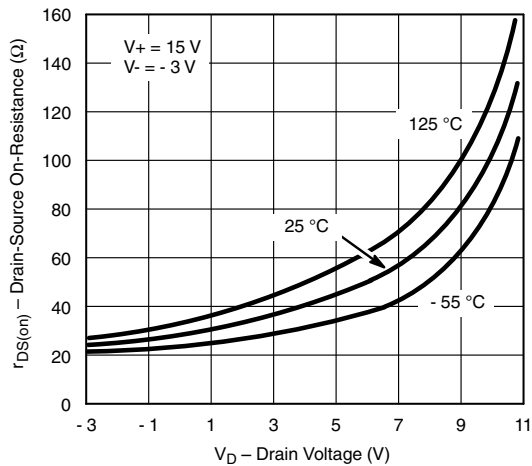

$R_{DS(on)}$ vs. Drain Voltage

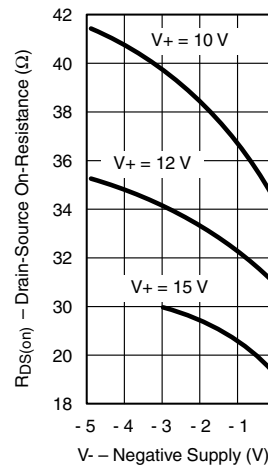

V_+ Constant

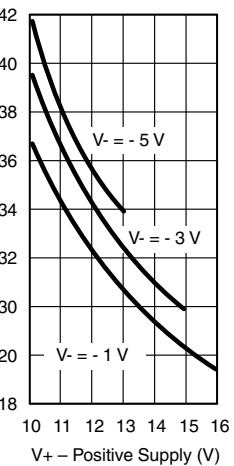

V_- Constant

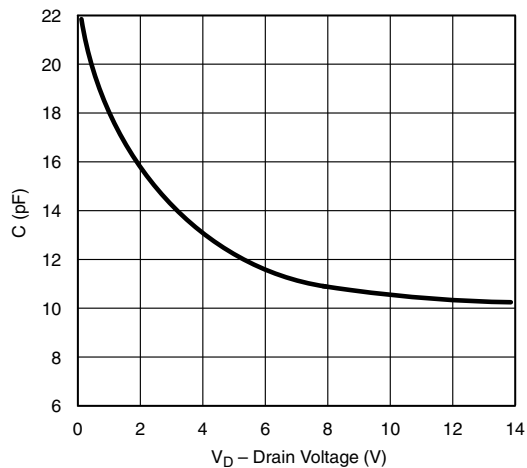

On Capacitance

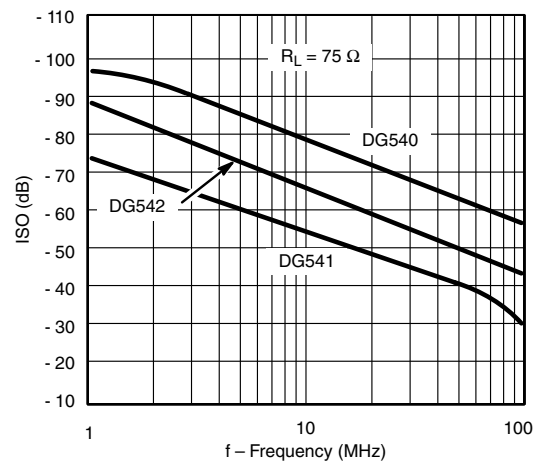

Off Isolation

TYPICAL CHARACTERISTICS ($T_A = 25\text{ }^\circ\text{C}$, unless otherwise noted)

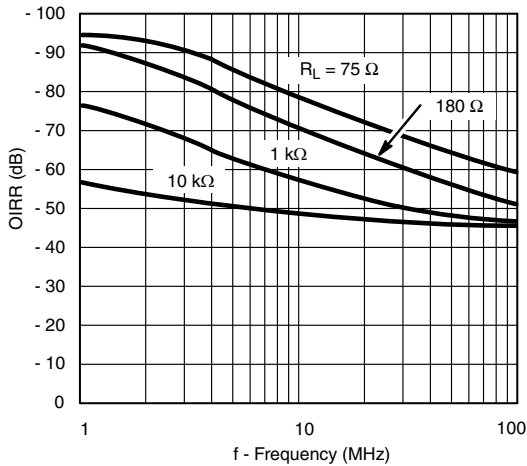

Off Isolation vs. Frequency and Load Resistance (DG540)

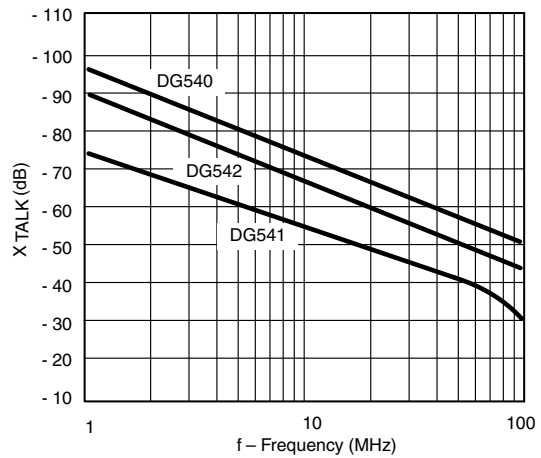

All Hostile Crosstalk

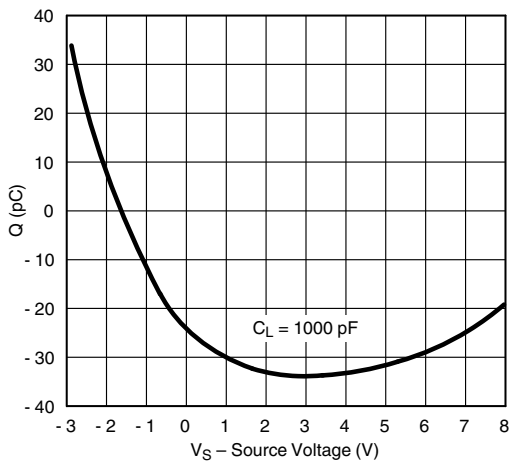

Charge Injection vs. V_S

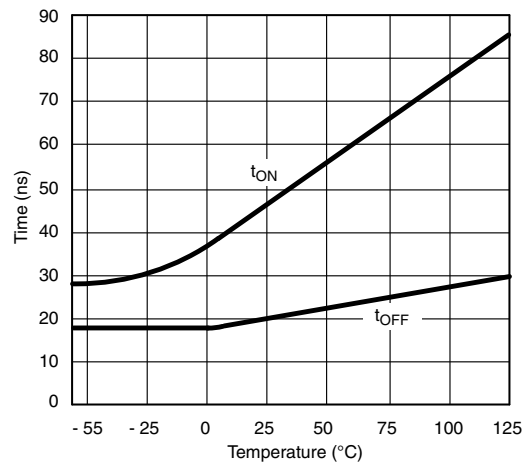

Switching Times vs. Temperature (DG540/541)

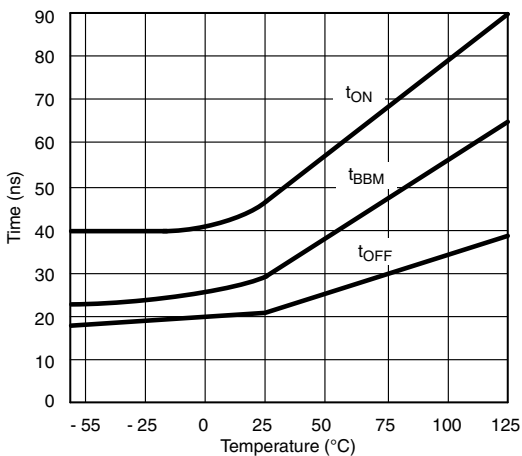

Switching and Break-Before-Make Time vs. Temperature (DG542)

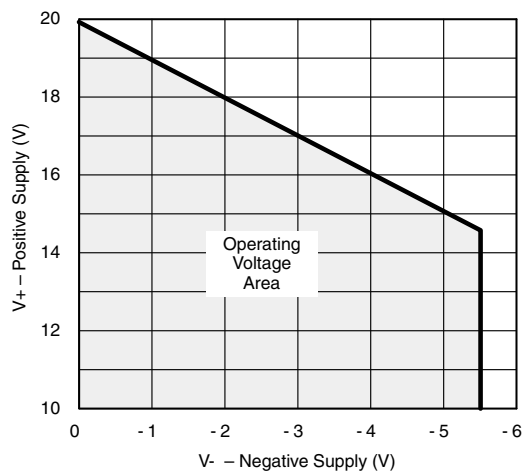

Operating Supply Voltage Range

TEST CIRCUITS

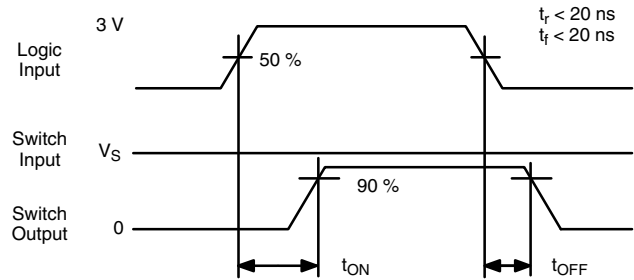
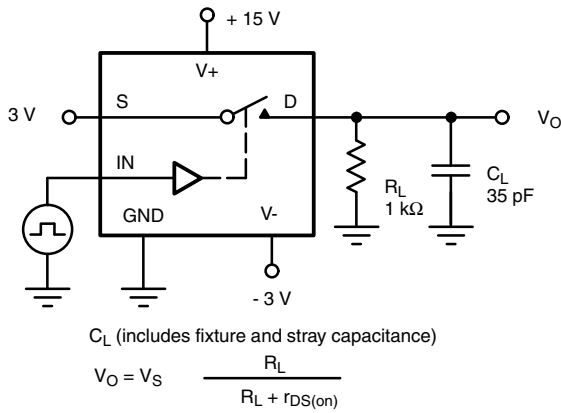
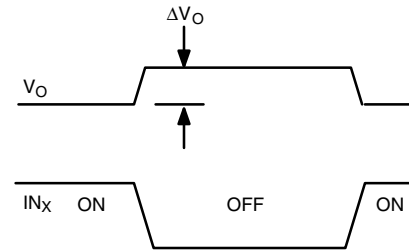
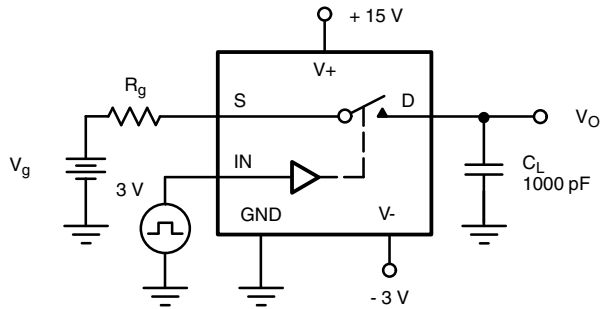

Figure 2. Switching Time



ΔV_O = measured voltage error due to charge injection
The charge injection in coulombs is $\Delta Q = C_L \times \Delta V_O$

Figure 3. Charge Injection

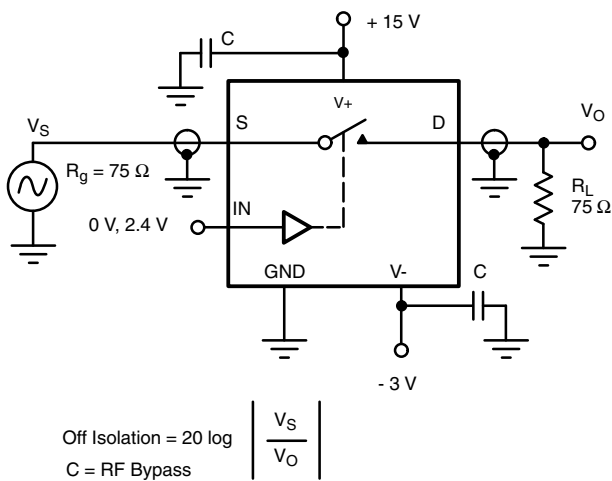

Figure 4. Off Isolation

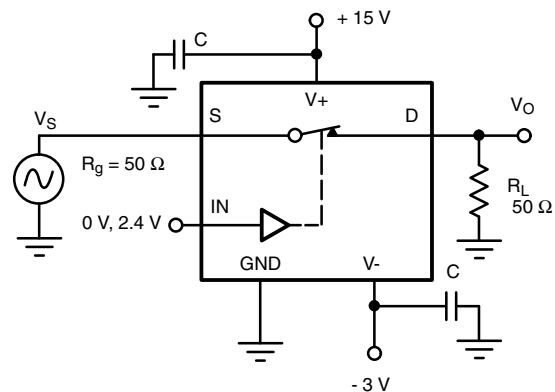

Figure 5. Bandwidth

TEST CIRCUITS

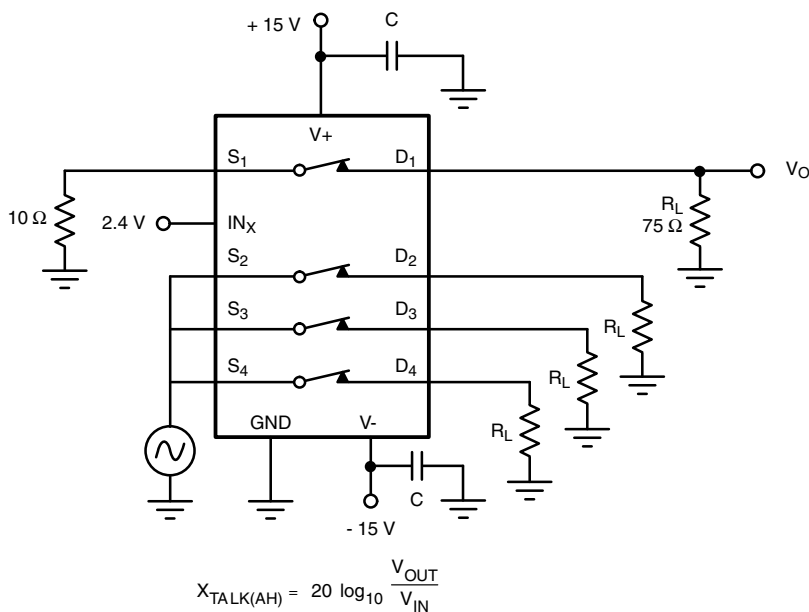

Figure 6. All Hostile Crosstalk

APPLICATIONS

Device Description

The DG540, DG541, DG542 family of wideband switches offers true bidirectional switching of high frequency analog or digital signals with minimum signal crosstalk, low insertion loss, and negligible non-linearity distortion and group delay. Built on the Siliconix D/CMOS process, these "T" switches provide excellent off-isolation with a bandwidth of around 500 MHz (350 MHz for DG541). Silicon-gate D/CMOS processing also yields fast switching speeds.

An on-chip regulator circuit maintains TTL input compatibility over the whole operating supply voltage range, easing control logic interfacing.

Circuit layout is facilitated by the interchangeability of source and drain terminals.

Frequency Response

A single switch on-channel exhibits both resistance ($R_{\text{DS(on)}}$) and capacitance ($C_{\text{S(on)}}$). This RC combination has an attenuation effect on the analog signal – which is frequency dependent (like an RC low-pass filter). The -3-dB bandwidth of the DG540 is typically 500 MHz (into 50 Ω). This measured figure of 500 MHz illustrates that the switch channel can not be represented by a two stage RC combination. The on capacitance of the channel is distributed along the on-resistance, and hence becomes a more complex multi stage network of R's and C's making up the total $R_{\text{DS(on)}}$ and $C_{\text{S(on)}}$. See Application Note AN502 for more details.

Off-Isolation and Crosstalk

Off-isolation and crosstalk are affected by the load resistance and parasitic inter-electrode capacitances. Higher off-isolation is achieved with lower values of R_{L} . However, low values of R_{L} increase insertion loss requiring gain adjustments down the line. Stray capacitances, even a fraction of 1 pF, can cause a large crosstalk increase. Good layout and ground shielding techniques can considerably improve your ac circuit performance.

APPLICATIONS

Power Supplies

A useful feature of the DG54X family is its power supply flexibility. It can be operated from a single positive supply (V+) if required (V- connected to ground).

Note that the analog signal must not exceed V- by more than -0.3 V to prevent forward biasing the substrate p-n junction.

The use of a V- supply has a number of advantages:

1. It allows flexibility in analog signal handling, i.e., with $V_- = -5\text{ V}$ and $V_+ = 12\text{ V}$; up to $\pm 5\text{ V}$ ac signals can be controlled.
2. The value of on capacitance [$C_{S(on)}$] may be reduced. A property known as 'the body-effect' on the DMOS switch devices causes various parametric effects to occur. One of these effects is the reduction in $C_{S(on)}$ for an increasing V body-source. Note, however, that to increase V- normally requires V+ to be reduced (since $V_+ \text{ to } V_- = 21\text{ V max.}$). Reduction in V+ causes an increase in $R_{DS(on)}$, hence a compromise has to be achieved. It is also useful to note that optimum video linearity performance (e.g., differential phase and gain) occurs when V- is around -3 V.
3. V- eliminates the need to bias the analog signal using potential dividers and large coupling capacitors.

Decoupling

It is an established RF design practice to incorporate sufficient bypass capacitors in the circuit to decouple the power supplies to all active devices in the circuit. The dynamic performance of the DG54X is adversely affected by poor decoupling of power supply pins. Also, of even more significance, since the substrate of the device is connected to the negative supply, adequate decoupling of this pin is essential.

Rules:

1. Decoupling capacitors should be incorporated on all power supply pins (V+, V-). (See Figure 7.)
2. They should be mounted as close as possible to the device pins.
3. Capacitors should have good high frequency characteristics - tantalum bead and/or monolithic ceramic types are adequate. Suitable decoupling capacitors are 1- to 10 μF tantalum bead, plus 10- to 100 nF ceramic.

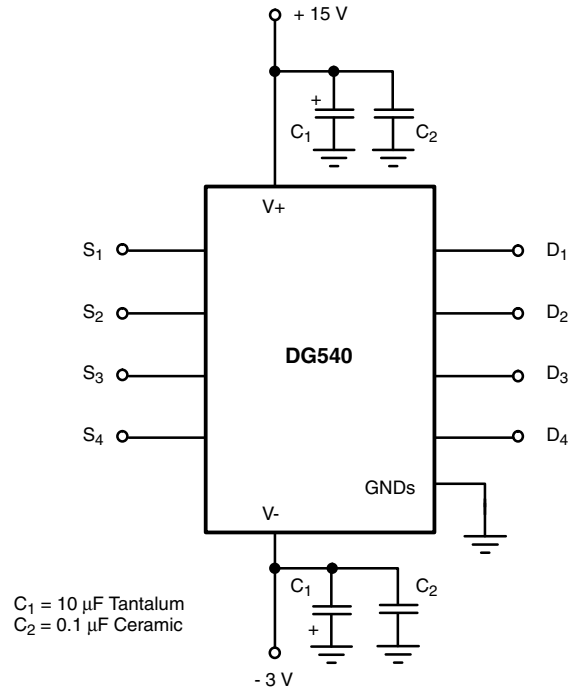

Figure 7. Supply Decoupling

Board Layout

PCB layout rules for good high frequency performance must be observed to achieve the performance boasted by the DG540. Some tips for minimizing stray effects are:

1. Use extensive ground planes on double sided PCB, separating adjacent signal paths. Multilayer PCB is even better.
2. Keep signal paths as short as practically possible, with all channel paths of near equal length.
3. Careful arrangement of ground connections is also very important. Star connected system grounds eliminate signal current flowing through ground path parasitic resistance from coupling between channels.

APPLICATIONS

Figure 8 shows a 4 Channel video multiplexer using a DG540.

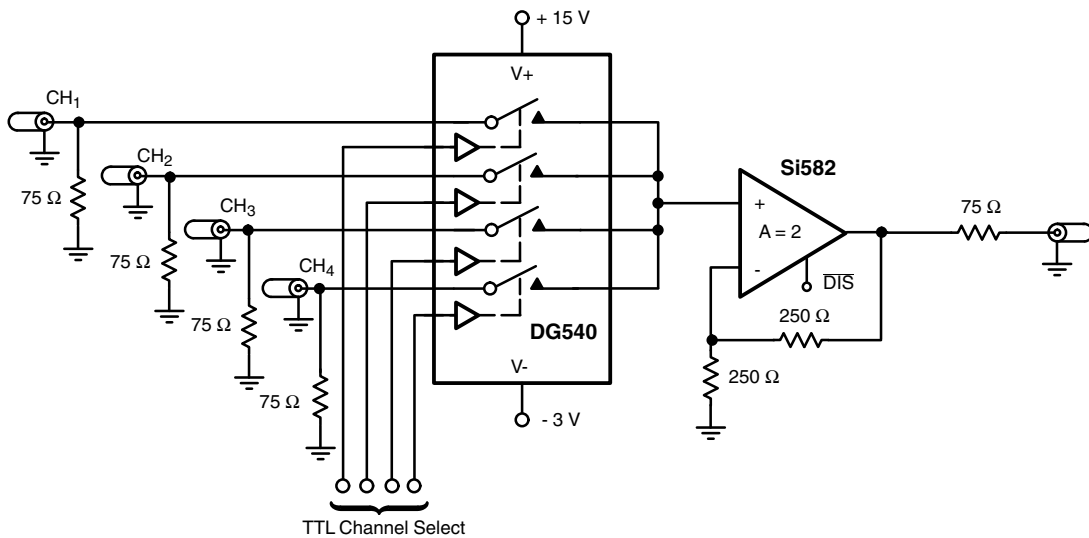

Figure 8. 4 by 1 Video Multiplexing Using the DG540

Figure 9 shows an RGB selector switch using two DG542s.

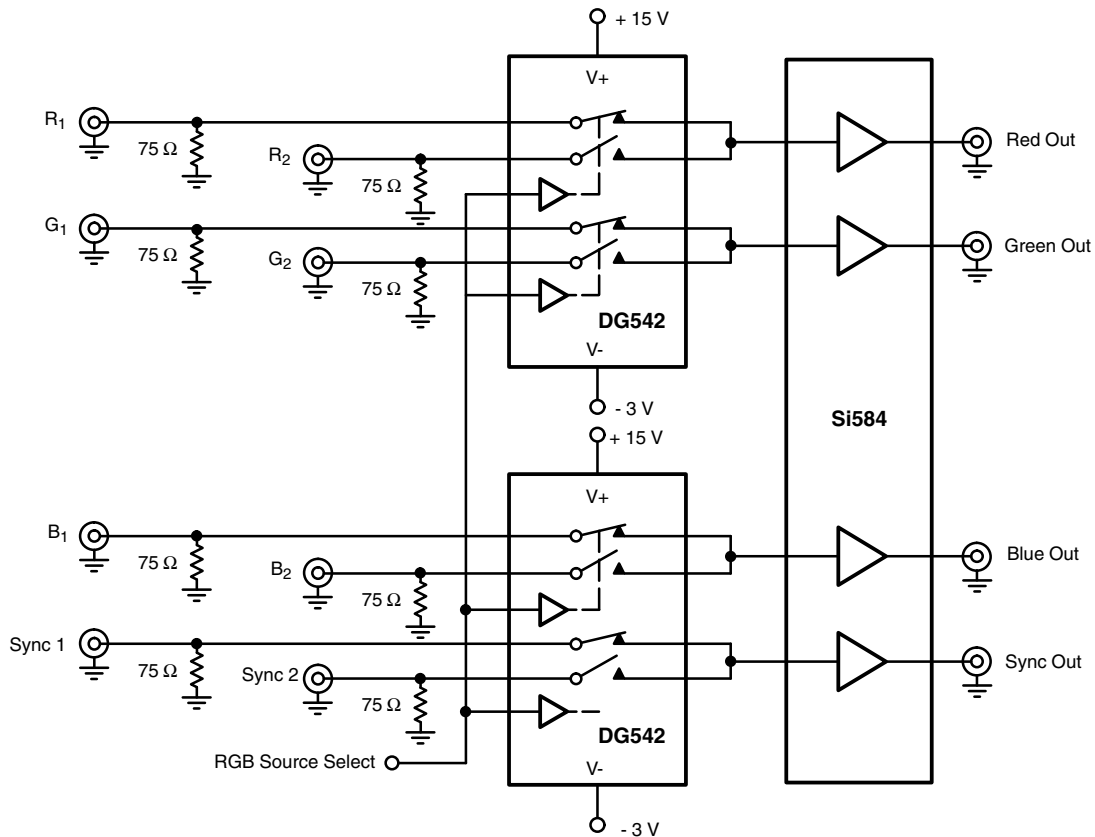
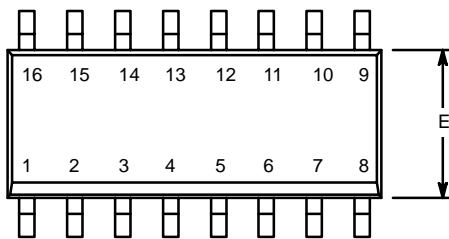

Figure 9. RGB Selector Using Two DG542s

Vishay Siliconix maintains worldwide manufacturing capability. Products may be manufactured at one of several qualified locations. Reliability data for Silicon Technology and Package Reliability represent a composite of all qualified locations. For related documents such as package/tape drawings, part marking, and reliability data, see www.vishay.com/ppg?70055.



SOIC (NARROW): 16-LEAD
JEDEC Part Number: MS-012



Dim	MILLIMETERS		INCHES	
	Min	Max	Min	Max
A	1.35	1.75	0.053	0.069
A ₁	0.10	0.20	0.004	0.008
B	0.38	0.51	0.015	0.020
C	0.18	0.23	0.007	0.009
D	9.80	10.00	0.385	0.393
E	3.80	4.00	0.149	0.157
e	1.27 BSC		0.050 BSC	
H	5.80	6.20	0.228	0.244
L	0.50	0.93	0.020	0.037
∅	0°	8°	0°	8°

ECN: S-03946—Rev. F, 09-Jul-01
DWG: 5300

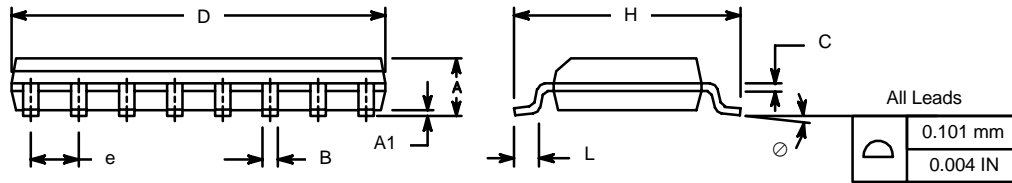

PDIP: 16-LEAD

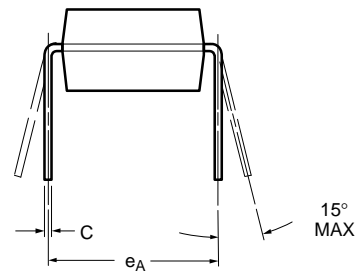
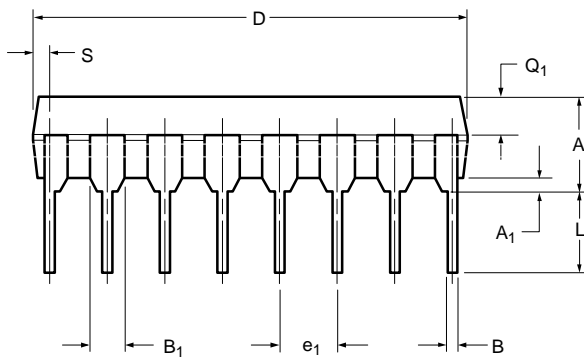
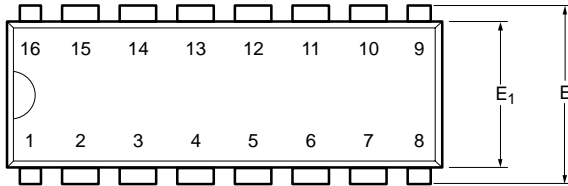

Dim	MILLIMETERS		INCHES	
	Min	Max	Min	Max
A	3.81	5.08	0.150	0.200
A₁	0.38	1.27	0.015	0.050
B	0.38	0.51	0.015	0.020
B₁	0.89	1.65	0.035	0.065
C	0.20	0.30	0.008	0.012
D	18.93	21.33	0.745	0.840
E	7.62	8.26	0.300	0.325
E₁	5.59	7.11	0.220	0.280
e₁	2.29	2.79	0.090	0.110
e_A	7.37	7.87	0.290	0.310
L	2.79	3.81	0.110	0.150
Q₁	1.27	2.03	0.050	0.080
S	0.38	1.52	.015	0.060

ECN: S-03946—Rev. D, 09-Jul-01
DWG: 5482

PDIP: 20-LEAD

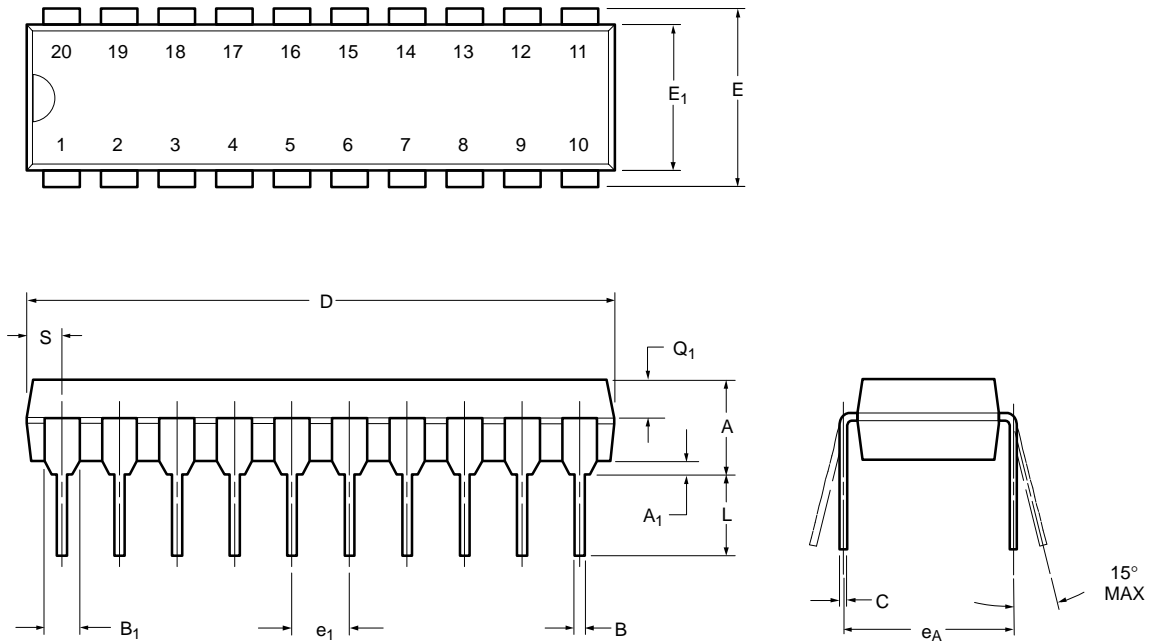

Dim	MILLIMETERS		INCHES	
	Min	Max	Min	Max
A	3.81	5.08	0.150	0.200
A₁	0.38	1.27	0.015	0.050
B	0.38	0.51	0.015	0.020
B₁	0.89	1.65	0.035	0.065
C	0.20	0.30	0.008	0.012
D	24.89	26.92	0.980	1.060
E	7.62	8.26	0.300	0.325
E₁	5.59	7.11	0.220	0.280
e₁	2.29	2.79	0.090	0.110
e_A	7.37	7.87	0.290	0.310
L	3.175	3.81	0.123	0.150
Q₁	1.27	2.03	0.050	0.080
S	1.02	2.03	0.040	0.080

ECN: S-03946—Rev. B, 09-Jul-01
DWG: 5484



PLCC: 20-LEAD

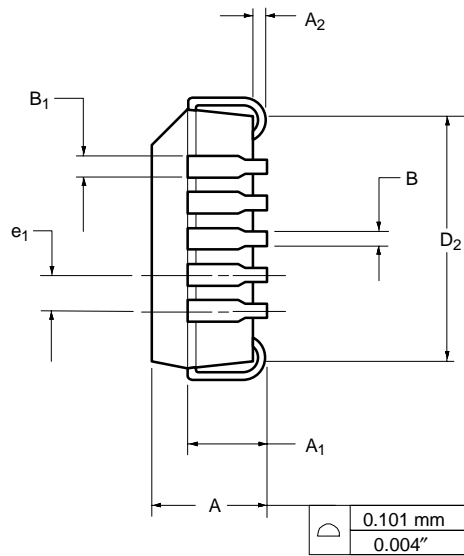
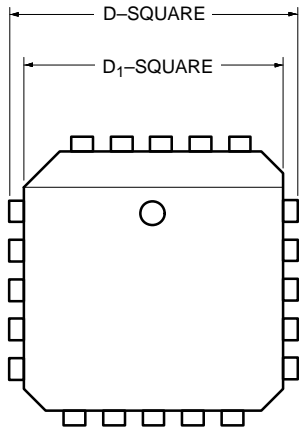

Dim	MILLIMETERS		INCHES	
	Min	Max	Min	Max
A	4.20	4.57	0.165	0.180
A₁	2.29	3.04	0.090	0.120
A₂	0.51	–	0.020	–
B	0.331	0.553	0.013	0.021
B₁	0.661	0.812	0.026	0.032
D	9.78	10.03	0.385	0.395
D₁	8.890	9.042	0.350	0.356
D₂	7.37	8.38	0.290	0.330
e₁	1.27 BSC		0.050 BSC	

ECN: S-03946—Rev. C, 09-Jul-01
DWG: 5306



SIDEBRAZE: 16-LEAD

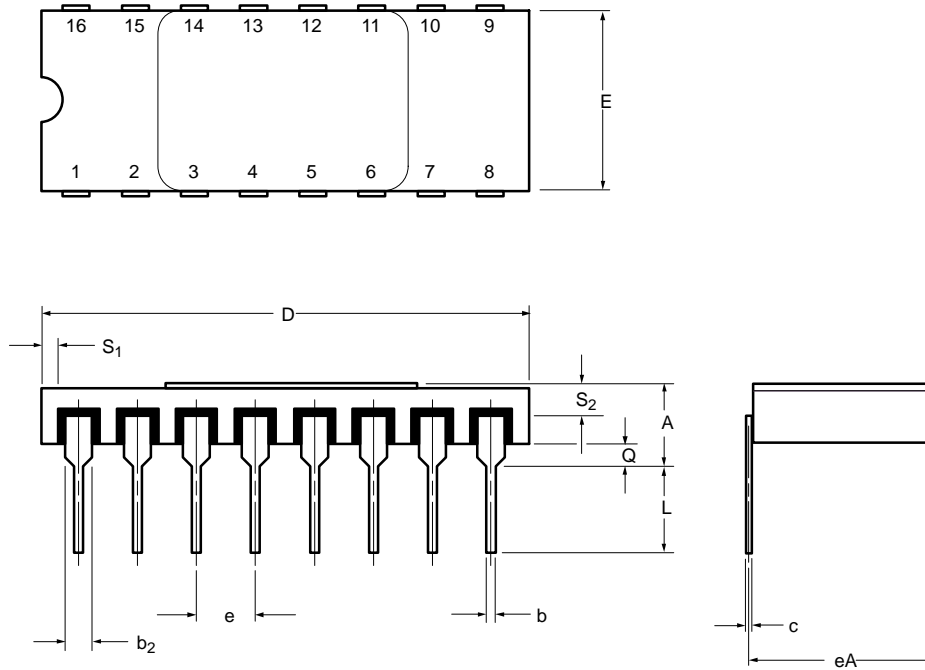

Dim	MILLIMETERS		INCHES	
	Min	Max	Min	Max
A	2.67	4.45	0.105	0.175
b	0.38	0.53	0.015	0.021
b₂	1.14	1.65	0.045	0.065
c	0.20	0.30	0.008	0.012
D	19.56	21.08	0.770	0.830
E	7.11	7.87	0.280	0.310
e	2.54 BSC		0.100 BSC	
e_A	7.62 BSC		0.300 BSC	
L	3.18	4.45	0.125	0.175
Q	0.64	1.40	0.025	0.055
S₂	0.25	–	0.010	–
S₁	0.13	–	0.005	–

ECN: S-03946—Rev. G, 09-Jul-01
DWG: 5418



SIDBRAZE: 20-LEAD

Meets MIL-STD-1835, D8, Configuration C

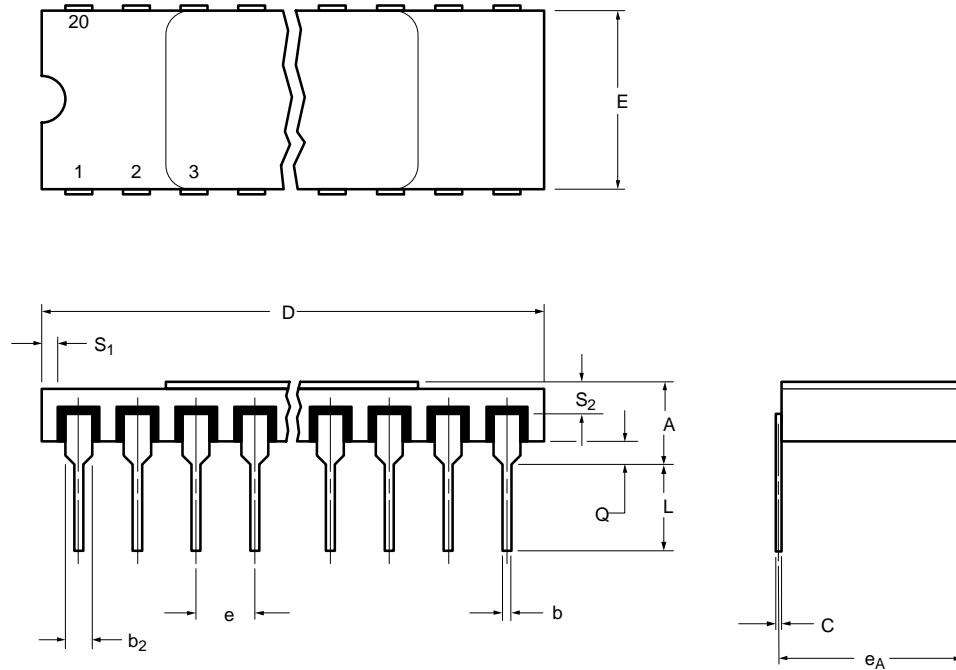

Dim	MILLIMETERS		INCHES	
	Min	Max	Min	Max
A	2.67	4.45	0.105	0.175
b	0.38	0.53	0.015	0.021
b₂	1.14	1.65	0.045	0.065
c	0.20	0.30	0.008	0.012
D	24.89	26.16	0.980	1.030
E	7.11	7.87	0.280	0.310
e	2.54 BSC		0.100 BSC	
e_A	7.62 BSC		0.300 BSC	
L	3.18	4.45	0.125	0.175
Q	0.64	1.40	0.025	0.055
S₂	0.25	–	0.010	–
S₁	0.13	–	0.005	–

ECN: S-03946—Rev. D, 09-Jul-01
DWG: 5309

RECOMMENDED MINIMUM PADS FOR SO-16

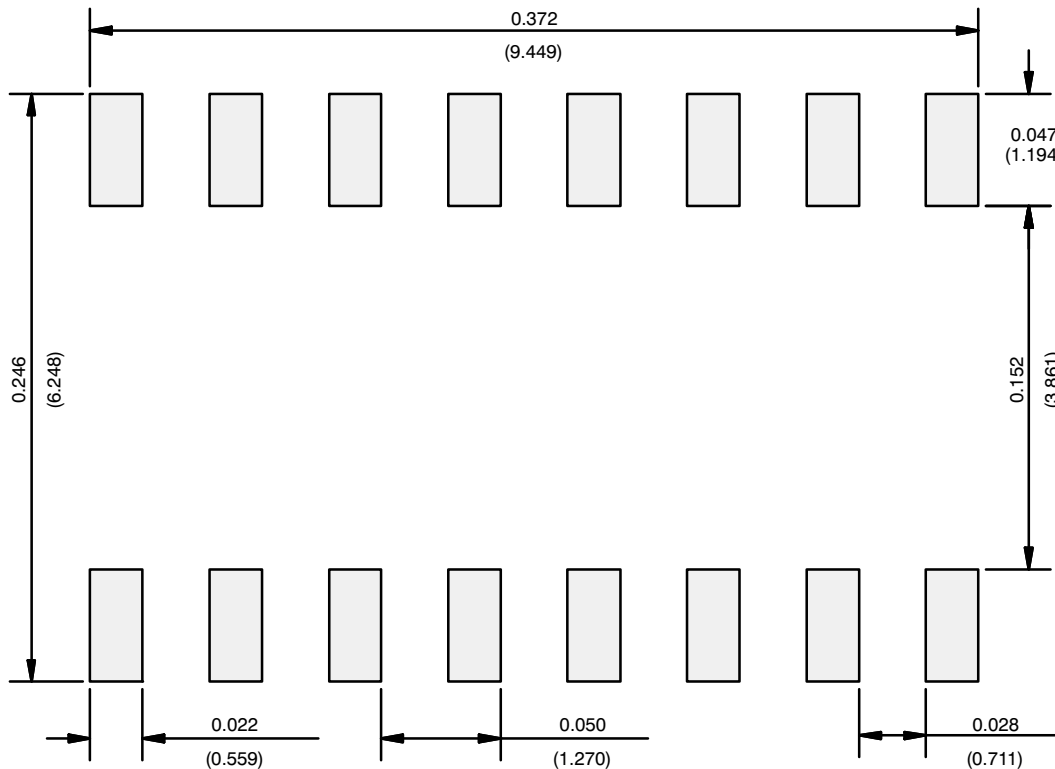

Recommended Minimum Pads
Dimensions in Inches/(mm)

[Return to Index](#)



Disclaimer

ALL PRODUCT, PRODUCT SPECIFICATIONS AND DATA ARE SUBJECT TO CHANGE WITHOUT NOTICE TO IMPROVE RELIABILITY, FUNCTION OR DESIGN OR OTHERWISE.

Vishay Intertechnology, Inc., its affiliates, agents, and employees, and all persons acting on its or their behalf (collectively, "Vishay"), disclaim any and all liability for any errors, inaccuracies or incompleteness contained in any datasheet or in any other disclosure relating to any product.

Vishay makes no warranty, representation or guarantee regarding the suitability of the products for any particular purpose or the continuing production of any product. To the maximum extent permitted by applicable law, Vishay disclaims (i) any and all liability arising out of the application or use of any product, (ii) any and all liability, including without limitation special, consequential or incidental damages, and (iii) any and all implied warranties, including warranties of fitness for particular purpose, non-infringement and merchantability.

Statements regarding the suitability of products for certain types of applications are based on Vishay's knowledge of typical requirements that are often placed on Vishay products in generic applications. Such statements are not binding statements about the suitability of products for a particular application. It is the customer's responsibility to validate that a particular product with the properties described in the product specification is suitable for use in a particular application. Parameters provided in datasheets and / or specifications may vary in different applications and performance may vary over time. All operating parameters, including typical parameters, must be validated for each customer application by the customer's technical experts. Product specifications do not expand or otherwise modify Vishay's terms and conditions of purchase, including but not limited to the warranty expressed therein.

Except as expressly indicated in writing, Vishay products are not designed for use in medical, life-saving, or life-sustaining applications or for any other application in which the failure of the Vishay product could result in personal injury or death. Customers using or selling Vishay products not expressly indicated for use in such applications do so at their own risk. Please contact authorized Vishay personnel to obtain written terms and conditions regarding products designed for such applications.

No license, express or implied, by estoppel or otherwise, to any intellectual property rights is granted by this document or by any conduct of Vishay. Product names and markings noted herein may be trademarks of their respective owners.

Looking for pricing, stock, or lifecycle information?

Click below to explore more details on WIN SOURCE:

 [View DG541DJ on WIN SOURCE](#)

 [Vishay Information](#)

Optimize Your Supply Chain with WIN SOURCE Solutions

-  Global Sourcing Solution
-  Obsolete Management
-  Cost Control Management
-  Shortage Management
-  Alternative Solution
-  Excess Inventory Management