



THE DATASHEET OF STM6519ALARUB6F



Single-pin, push button Smart Reset™

Datasheet - production data

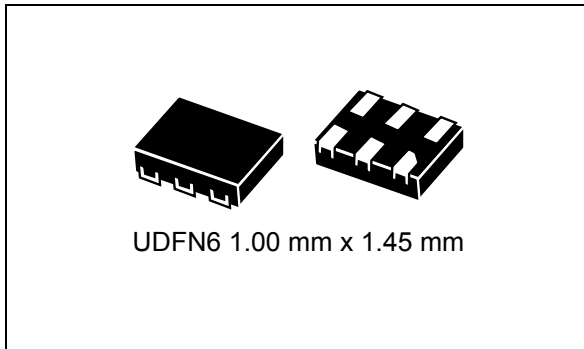
**Applications**

- Mobile phones, smartphones, PDAs
- e-books
- MP3 players
- Games
- Portable navigation devices
- Any application that requires delayed reset push-button response for improved system stability

Features

- Operating voltage range 2 V to 5.5 V
- Low supply current 1 μ A
- Integrated test mode
- Single Smart Reset™ push-button input with fixed extended reset setup delay (t_{SRC}) from 0.5 s to 10 s in 0.5 s steps (typ.), option with internal input pull-up resistor
- Push-button controlled reset pulse duration
- Option 1: fully push-button controlled, no fixed or minimum pulse width guaranteed
- Option 2: defined output reset pulse duration (t_{REC}), factory-programmed
- Single reset output
- Active-low or active-high
- Push-pull or open drain with optional pull-up resistor
- Fixed Smart Reset input logic voltage levels
- Operating temperature: -40 °C to 85 °C
- UDFN6 package 1.00 mm x 1.45 mm
- ECOPACK®2 (RoHS compliant, Halogen-Free)

Contents

1	Description	5
1.1	Test mode	5
1.2	Logic diagram	6
1.3	Pin connections	6
2	Device overview	7
3	Pin descriptions	8
3.1	Power supply (V_{CC})	8
3.2	Power-up sequence	8
3.3	Ground (V_{SS})	8
3.4	Smart Reset input (\overline{SR})	8
3.5	Reset output (\overline{RST})	8
3.6	\overline{RST} output undervoltage behavior (for open-drain option)	8
4	Typical application diagrams	9
5	Timing diagrams	11
6	Typical operating characteristics	12
7	Maximum ratings	14
8	DC and AC parameters	15
9	Package information	17
9.1	UDFN6 package information	17
9.2	Tape and reel information	19
10	Part numbering	20
11	Package marking information	21
12	Revision history	22

List of tables

Table 1.	Signal names	7
Table 2.	Absolute maximum ratings	14
Table 3.	Operating and measurement conditions	15
Table 4.	DC and AC characteristics	16
Table 5.	UDFN6 mechanical data	18
Table 6.	Ordering information scheme	20
Table 7.	Package marking	21
Table 8.	Document revision history	22

List of figures

Figure 1.	STM6519 logic diagram	6
Figure 2.	UDFN6 pin connections (top view)	6
Figure 3.	STM6519 block diagram	7
Figure 4.	Typical application diagram - input, output and STM6519 device in one voltage domain . . .	9
Figure 5.	Typical application diagram - STM6519 device in a different voltage domain than input and output.	9
Figure 6.	Typical application diagram in different voltage domains - \overline{SR} input in V_{BAT} domain like V_{CC} totally disables the test mode	10
Figure 7.	\overline{RST} output without t_{REC} option	11
Figure 8.	\overline{RST} output with t_{REC} option	11
Figure 9.	Supply current (I_{CC}) vs. temperature (T_A).	12
Figure 10.	Smart Reset delay (t_{SRC}) vs. temperature (T_A), $t_{SRC} = 4.0$ s (typ.)	12
Figure 11.	Test mode entry voltage (V_{TEST}) vs. temperature (T_A).	13
Figure 12.	Initial test mode time ($t_{SRC-INI}$) vs. temperature (T_A)	13
Figure 13.	UDFN6 package outline	17
Figure 14.	UDFN6 recommended footprint	18
Figure 15.	Carrier tape	19
Figure 16.	Pin 1 orientation	19
Figure 17.	Package marking (top view)	21

1 Description

The Smart Reset™ devices provide a useful feature which ensures that inadvertent short reset push-button closures do not cause system resets. This is done by implementing an extended Smart Reset input delay time (t_{SRC}), which ensures a safe reset and eliminates the need for a specific dedicated reset button.

This reset configuration provides versatility and allows the application to distinguish between a software generated interrupt and a hard system reset. When the input push-button is connected to the microcontroller interrupt input, and is closed for a short time, the processor can only be interrupted. If the system still does not respond properly, continuing to keep the push-buttons closed for the extended setup time t_{SRC} causes a hard reset of the processor through the reset output.

The STM6519 has one Smart Reset input (\overline{SR}) with preset delayed Smart Reset setup time (t_{SRC}). The reset output (\overline{RST}) is asserted after the Smart Reset input is held active for the selected t_{SRC} delay time. The \overline{RST} output remains asserted either until the \overline{SR} input goes to inactive logic level (i.e. neither fixed nor minimum reset pulse width is set) or the output reset pulse duration is fixed for t_{REC} (i.e. factory-programmed). The device fully operates over a broad V_{CC} range from 2.0 V to 5.5 V.

1.1 Test mode

After pulling \overline{SR} up to V_{TEST} ($V_{CC} + 1.4$ V) or above, the counter starts to count the initial shortened $t_{SRC-INI}$ (42 ms, typ.). After $t_{SRC-INI}$ expires, the \overline{RST} output either goes down for t_{REC} (if t_{REC} option is used) or stays low as long as overvoltage on \overline{SR} is detected (if t_{REC} option is not used). This is feedback, and the user only knows that the device is locked in test mode. Each time the \overline{SR} input is connected to ground in test mode, a shortened $t_{SRC-SHORT}$ ($t_{SRC}/128$) is used instead of regular t_{SRC} (0.5 s - 10 s). In this way the device can be quickly tested without repeating test mode triggering. Return to normal mode is possible by performing a new startup of the device (i.e. V_{CC} goes to 0 V and back to its original state).

The advantages of this solution are its high glitch immunity, user feedback regarding entry into test mode, and testability within the full V_{CC} range.

1.2 Logic diagram

Figure 1. STM6519 logic diagram

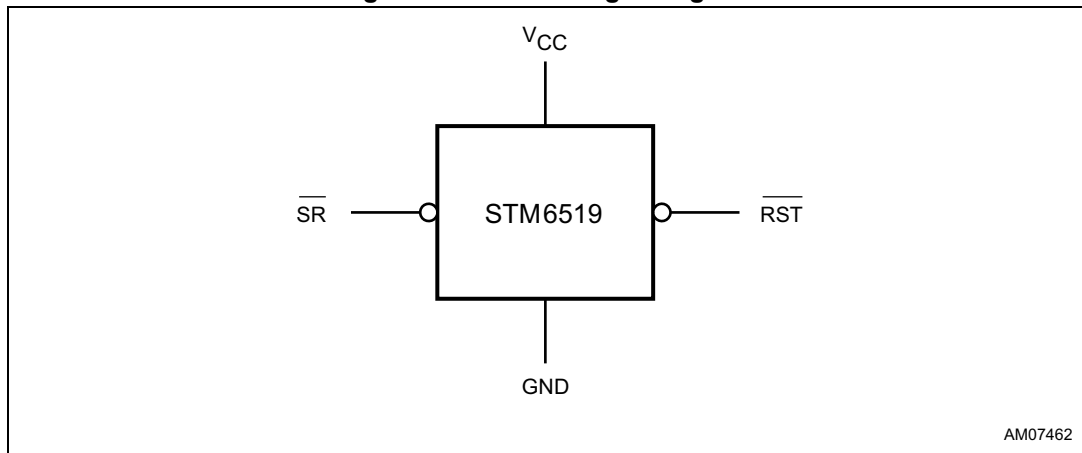

1.3 Pin connections

Figure 2. UDFN6 pin connections (top view)

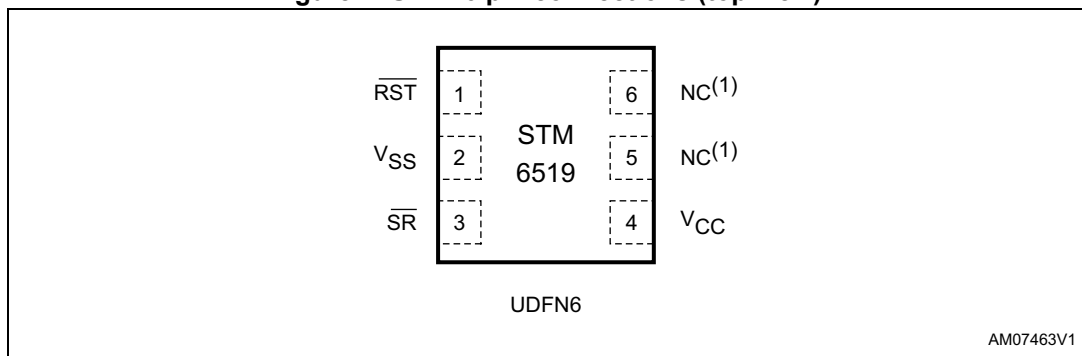

1. Not connected (not bonded); should be connected to V_{SS}.

2 Device overview

Table 1. Signal names

Pin number	Name	Type	Description
1	$\overline{\text{RST}}$	Output	Reset output, active-low, open drain.
2	V_{SS}	Supply ground	Ground
3	$\overline{\text{SR}}$	Input	Smart Reset input, active-low.
4	V_{CC}	Supply voltage	Positive supply voltage for the device. A 0.1 μF decoupling ceramic capacitor is recommended to be connected between V_{CC} and V_{SS} pins.
5	NC	-	Not connected (not bonded); should be connected to V_{SS} .
6	NC	-	Not connected (not bonded); should be connected to V_{SS} .

Figure 3. STM6519 block diagram

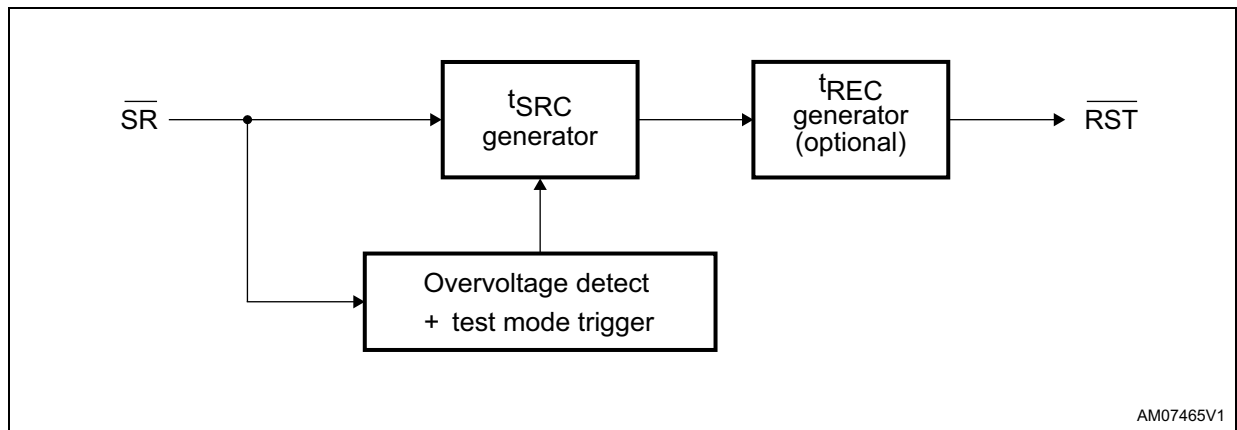

3 Pin descriptions

3.1 Power supply (V_{CC})

This pin is used to provide power to the Smart Reset device. A 0.1 μF ceramic decoupling capacitor is recommended to be connected between the V_{CC} and V_{SS} pins, as close to the STM6519 device as possible.

3.2 Power-up sequence

In normal mode, if different input side ($\overline{\text{SR}}$) and V_{CC} voltage domains are used, power-on sequence must avoid meeting the test mode entry condition to avoid inadvertent test mode entry: there should not be logic high present on the $\overline{\text{SR}}$ input before the V_{CC} power-up. However V_{CC} and $V(\overline{\text{SR}})$ rising at the same time is OK (e.g. if both are in the same voltage domain), the device will then safely start into normal operating mode, with $\overline{\text{RST}}$ output inactive (in High-Z mode for open-drain option).

3.3 Ground (V_{SS})

This is the ground pin for the device.

3.4 Smart Reset input ($\overline{\text{SR}}$)

Push-button Smart Reset input, active-low with optional pull-up resistor. $\overline{\text{SR}}$ input needs to be asserted for at least t_{SRC} to assert the reset output ($\overline{\text{RST}}$).

By connecting a voltage higher than $V_{CC} + 1.4 \text{ V}$ to the $\overline{\text{SR}}$ input the device enters test mode (see [Section 1: Description on page 5](#) for more information).

3.5 Reset output ($\overline{\text{RST}}$)

$\overline{\text{RST}}$ is active-low or active-high, open drain or push-pull reset output with optional internal pull-up resistor.

Output reset pulse width is optional as follows:

- Neither fixed nor minimum output reset pulse duration (releasing the push-button while reset output is active, causes the output to de-assert)
- Fixed, factory-programmed output reset pulse duration for t_{REC} independent on Smart Reset input state.

3.6 $\overline{\text{RST}}$ output undervoltage behavior (for open-drain option)

High-Z on $\overline{\text{RST}}$ output below the specified operating voltage range is guaranteed at V_{CC} power-on or in case that valid V_{CC} dropped while the device was idle, i.e. while both output and input were inactive.

4 Typical application diagrams

Figure 4. Typical application diagram - input, output and STM6519 device in one voltage domain

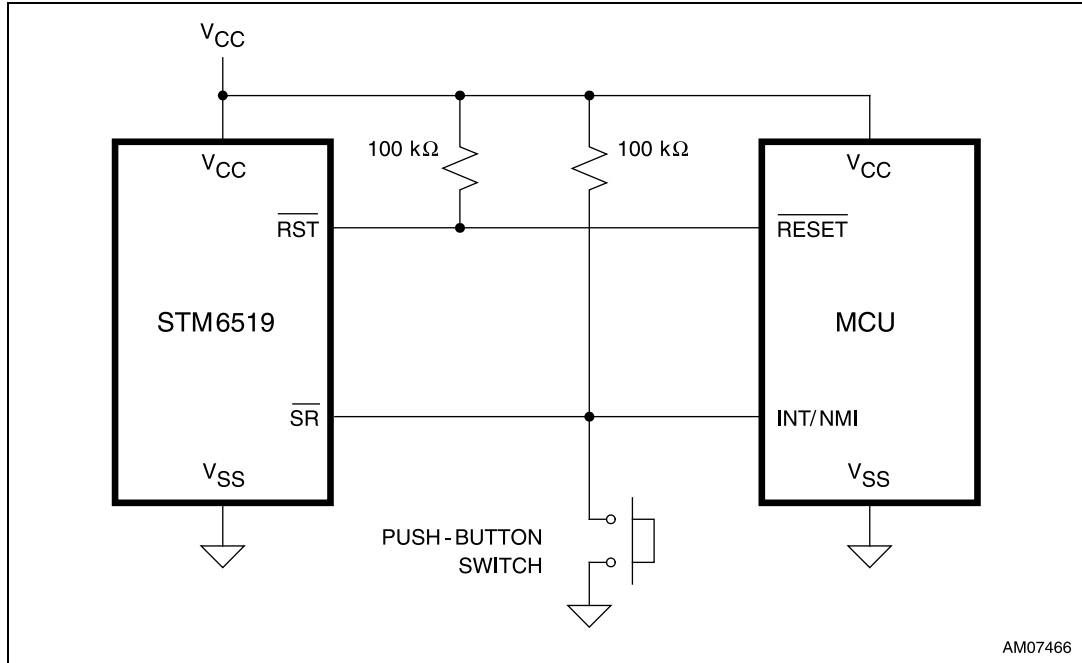

AM07466

Figure 5. Typical application diagram - STM6519 device in a different voltage domain than input and output

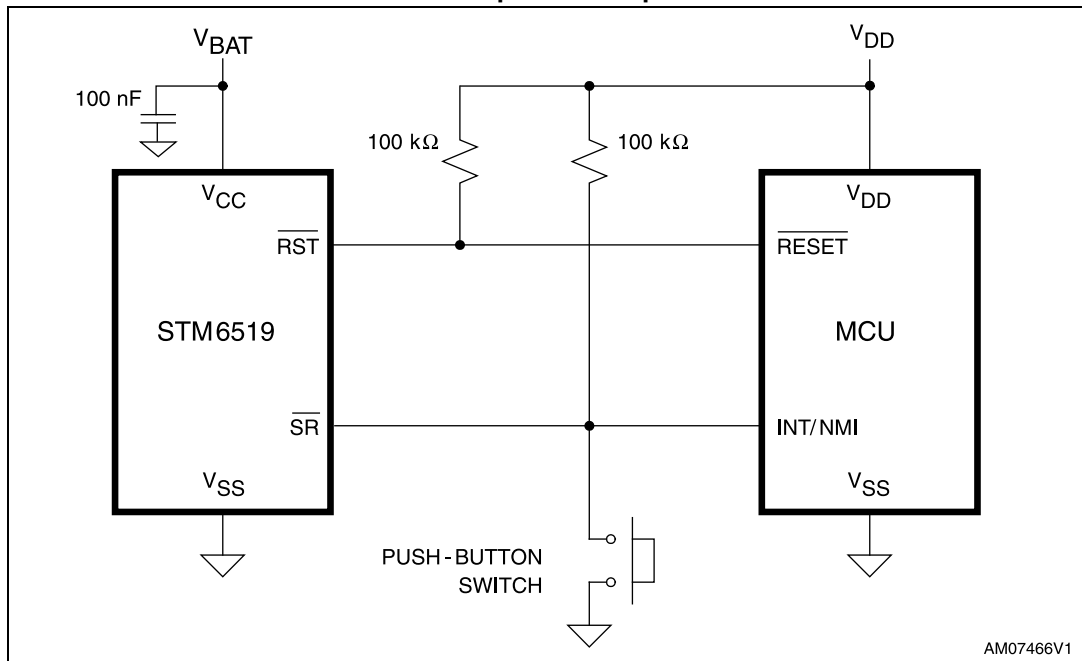

AM07466V1

1. Open-drain \overline{RST} output type and fixed \overline{SR} input logic threshold allows to use the device in different voltage domains. To prevent entering test mode by creating a condition $V(SR) > V_{CC} + 1.1 \text{ V typ.}$, V_{CC} should be powered up before or together with voltage on the SR input.

Figure 6. Typical application diagram in different voltage domains - \overline{SR} input in V_{BAT} domain like V_{CC} totally disables the test mode

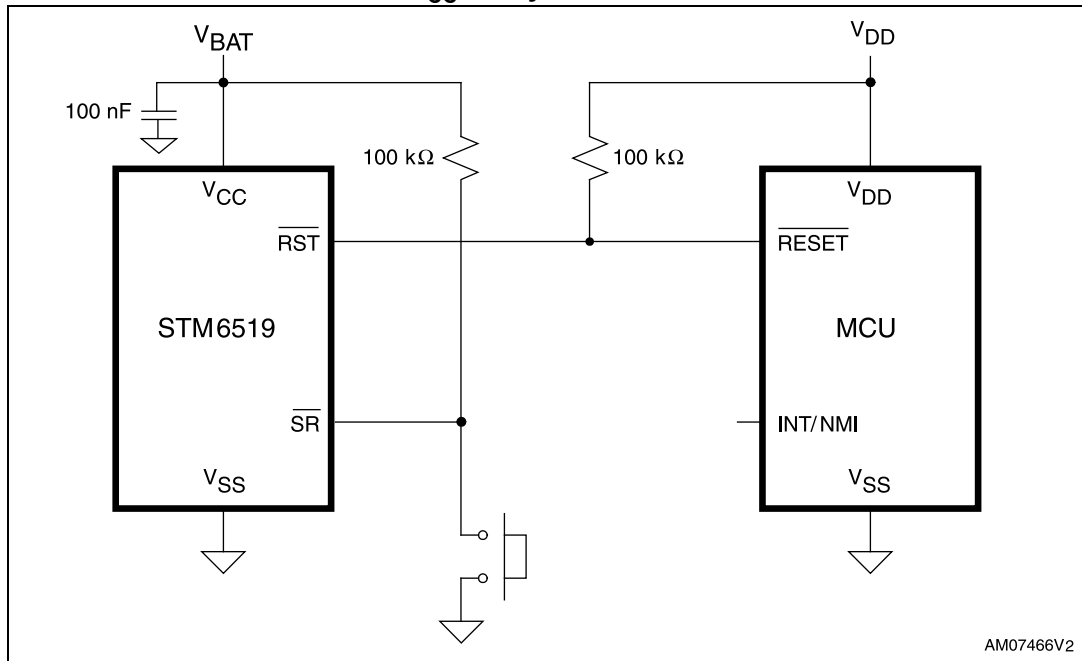

5 Timing diagrams

Figure 7. $\overline{\text{RST}}$ output without t_{REC} option

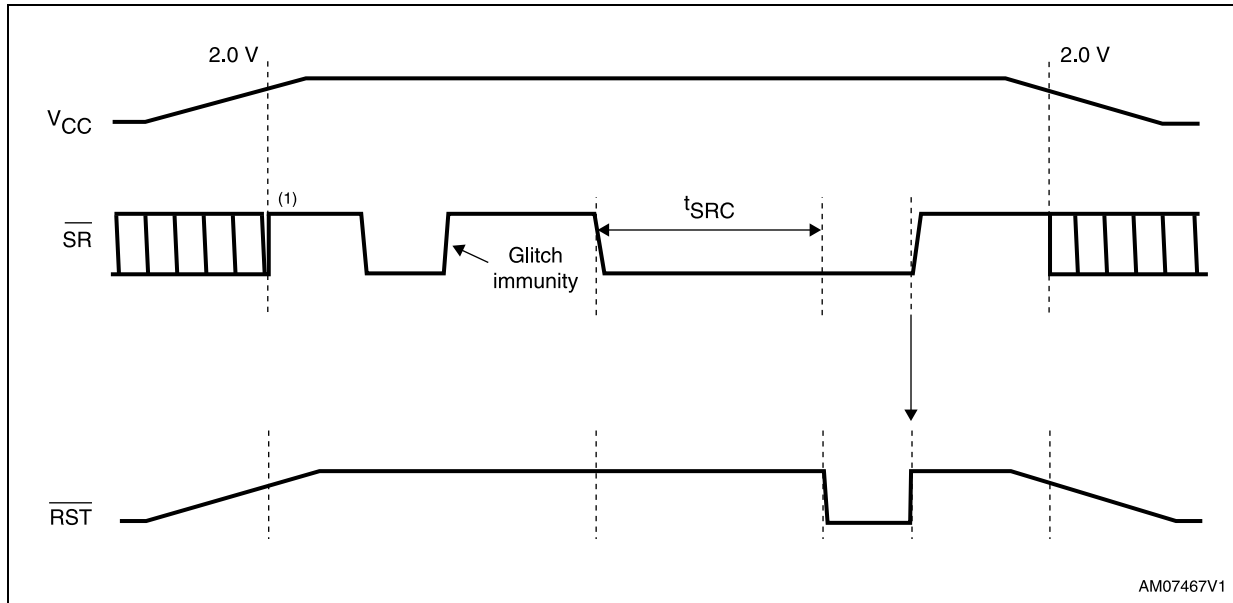

1. V_{CC} should be powered up before or together with voltage on the $\overline{\text{SR}}$ input to prevent entering test mode by creating a condition $V(\text{SR}) > V_{\text{CC}} + 1.1 \text{ V typ.}$

Figure 8. $\overline{\text{RST}}$ output with t_{REC} option

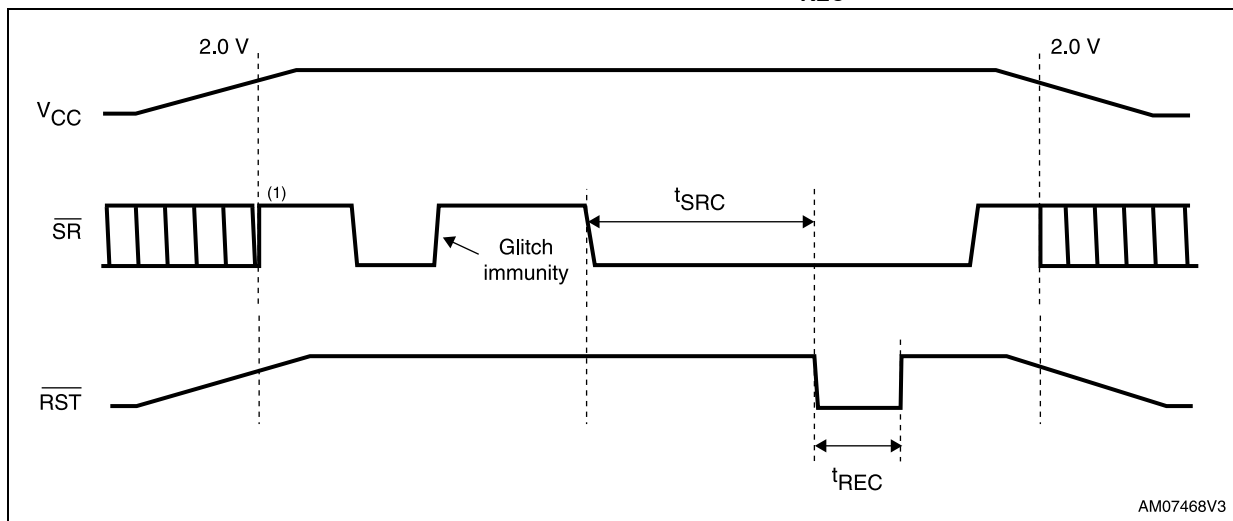

1. V_{CC} should be powered up before or together with voltage on the $\overline{\text{SR}}$ input to prevent entering test mode by creating a condition $V(\text{SR}) > V_{\text{CC}} + 1.1 \text{ V typ.}$

6 Typical operating characteristics

Figure 9. Supply current (I_{CC}) vs. temperature (T_A)

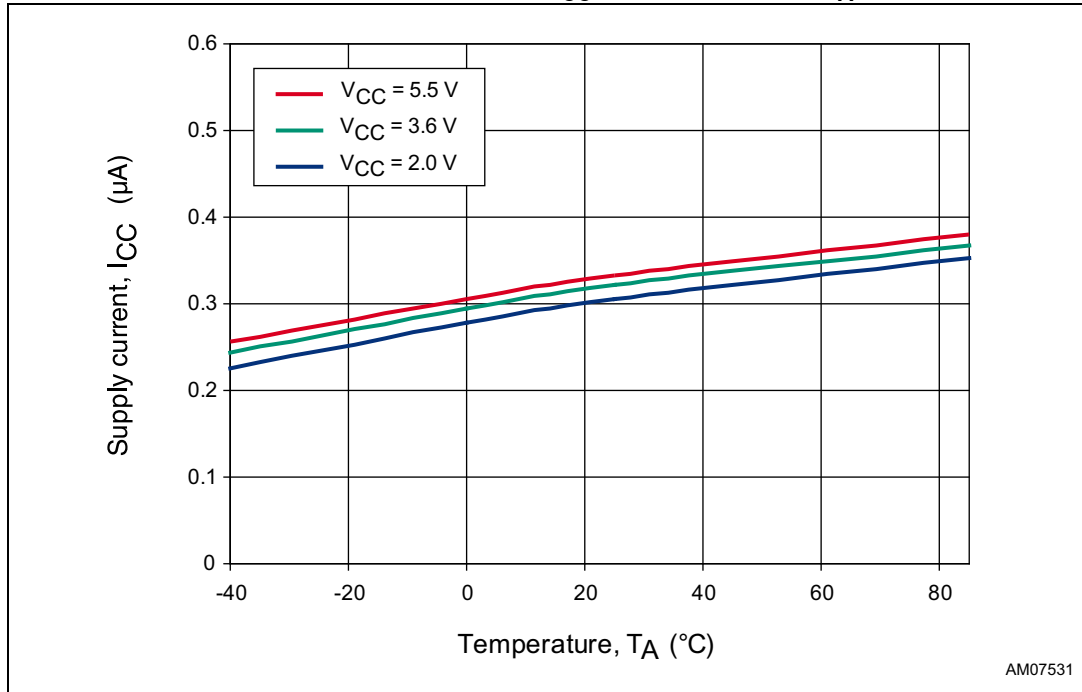

Figure 10. Smart Reset delay (t_{SRC}) vs. temperature (T_A), $t_{SRC} = 4.0\text{ s}$ (typ.)

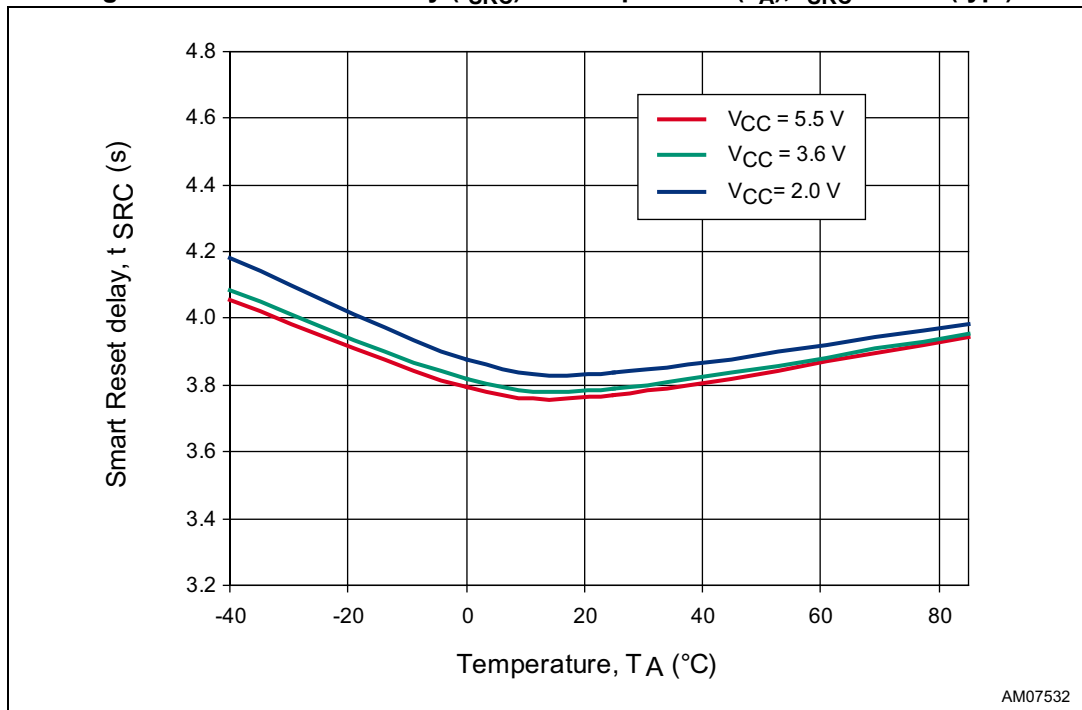

Figure 11. Test mode entry voltage (V_{TEST}) vs. temperature (T_A)

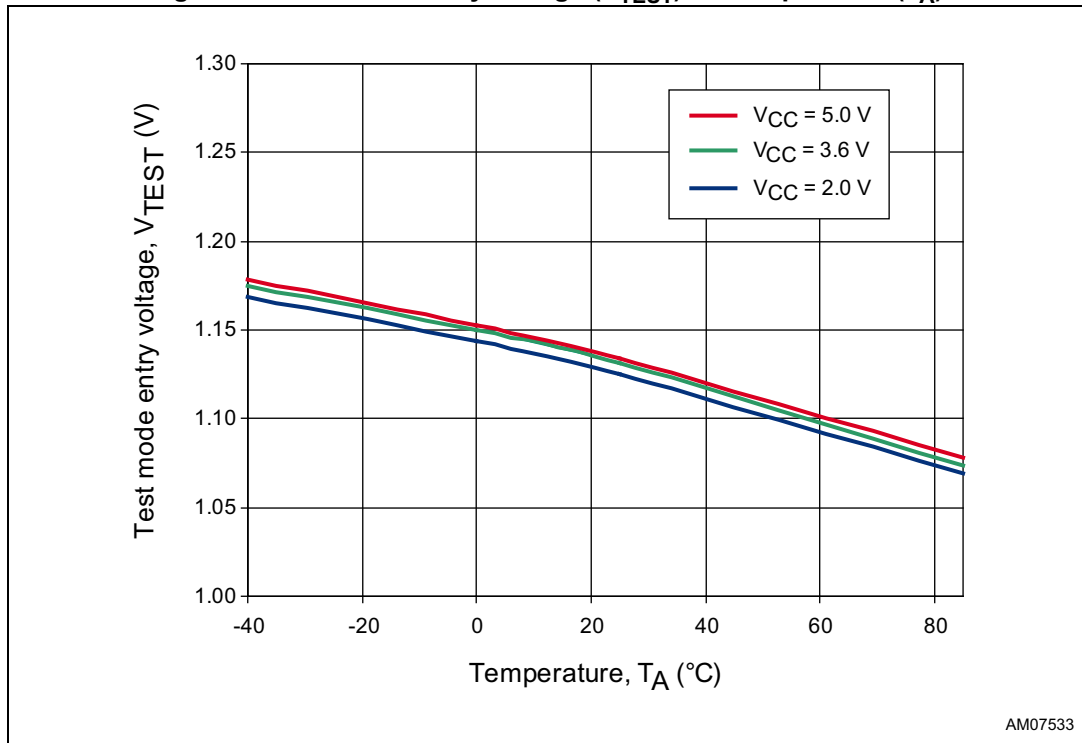
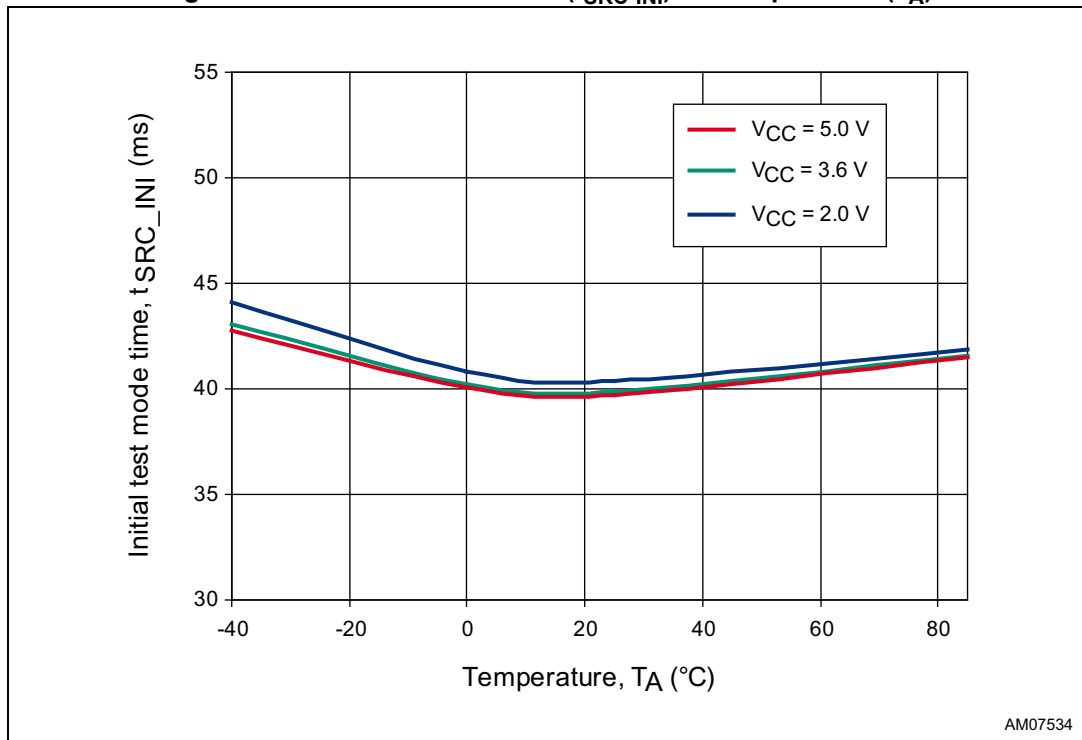

Figure 12. Initial test mode time (t_{SRC_INI}) vs. temperature (T_A)



7 Maximum ratings

Stressing the device above the rating listed in [Table 2: Absolute maximum ratings](#) may cause permanent damage to the device. These are stress ratings only and operation of the device at these or any other conditions above those indicated in [Table 3: Operating and measurement conditions](#) of this specification is not implied. Exposure to absolute maximum rating conditions for extended periods may affect device reliability. Refer also to the STMicroelectronics™ SURE program and other relevant quality documents.

Table 2. Absolute maximum ratings

Symbol	Parameter	Value	Unit
T_{STG}	Storage temperature (V_{CC} off)	-55 to 150	°C
$T_{SLD}^{(1)}$	Lead solder temperature for 10 seconds	260	°C
V_{IO}	Input or output voltage	-0.3 to 5.5	V
V_{CC}	Supply voltage	-0.3 to 7	V
ESD			
V_{HBM}	Electrostatic discharge protection, human body model (JESD22-A114-B level 2)	2	kV
V_{RCDM}	Electrostatic discharge protection, charged device model, all pins	1	kV
V_{MM}	Electrostatic discharge protection, machine model, all pins (JESD22-A115-A level A)	200	V
	Latch-up (V_{CC} pin, \overline{SR} reset input pin)	EIA/JESD78	

1. Reflow at peak temperature of 260 °C. The time above 255 °C must not exceed 30 seconds.

8 DC and AC parameters

This section summarizes the operating measurement conditions, and the DC and AC characteristics of the device. The parameters in [Table 4: DC and AC characteristics](#) are derived from tests performed under the measurement conditions summarized in [Table 3: Operating and measurement conditions](#). Designers should check that the operating conditions in their circuit match the operating conditions when relying on the quoted parameters.

Table 3. Operating and measurement conditions

Symbol	Parameter	Value	Unit
V_{CC}	Supply voltage	2.0 to 5.5	V
T_A	Ambient operating temperature	-40 to 85	°C
t_R, t_F	Input rise and fall times	≤ 5	ns
	Input pulse voltages	0.2 to 0.8 V_{CC}	V
	Input and output timing reference voltages	0.3 to 0.7 V_{CC}	V

Table 4. DC and AC characteristics

Symbol	Parameter	Test conditions ⁽¹⁾	Min.	Typ. ⁽²⁾	Max.	Unit
V _{CC}	Supply voltage		2.0		5.5	V
I _{CC}	Supply current	$\overline{SR} = V_{CC}$, t _{REC} and t _{SRC} counter is not running		0.4	1.0	μA
V _{OL}	Reset output voltage low	V _{CC} ≥ 4.5 V, sinking 3.2 mA			0.3	V
		V _{CC} ≥ 3.3 V, sinking 2.5 mA			0.3	V
		V _{CC} ≥ 2.0 V, sinking 1 mA			0.3	V
t _{REC}	Reset timeout delay, factory-programmed	(device option)	0.85	1.28	1.71	ms
			66	100	134	ms
			140	210	280	ms
			240	360	480	ms
R _{PUO}	Internal output pull-up resistor on RST	(device option)		65		kΩ
I _{LO}	Output leakage current	V _{RST} = 5.5 V, open drain device option without output pull-up resistor	-0.1		0.1	μA
Smart Reset						
t _{SRC}	Smart Reset delay	T _A = -40 to +85 °C	0.8 x t _{SRC}	t _{SRC} ⁽³⁾	1.2 x t _{SRC}	s
		T _A = 25 °C	0.9 x t _{SRC}		1.1 x t _{SRC}	
V _{IL}	\overline{SR} input voltage low		V _{SS} -0.3		0.3	V
V _{IH}	\overline{SR} input voltage high		0.85		5.5	V
R _{PUI}	Internal input pull-up resistor on SR	(device option)		65		kΩ
I _{LEAK}	\overline{SR} input leakage current	device option without input pull-up resistor	-0.1		0.1	μA
	Input glitch immunity			t _{SRC}		s
Test mode						
V _{TEST}	Test mode entry voltage		V _{CC} + 0.9	V _{CC} + 1.1	V _{CC} + 1.4	V
t _{SRC-INI}	Initial test mode time		28	42	56	ms
t _{SRC-SHORT}	Shortened Smart Reset delay			t _{SRC} / 128		ms

- Valid for ambient operating temperature T_A = -40 to 85 °C, V_{CC} = 2.0 to 5.5 V.
- Typical values are at 25 °C and V_{CC} = 3.3 V unless otherwise noted.
- Factory-programmable in the range of 0.5 s to 10 s typ. in 0.5 s steps.

9 Package information

In order to meet environmental requirements, ST offers these devices in different grades of ECOPACK® packages, depending on their level of environmental compliance. ECOPACK specifications, grade definitions and product status are available at: www.st.com. ECOPACK is an ST trademark.

9.1 UDFN6 package information

Figure 13. UDFN6 package outline

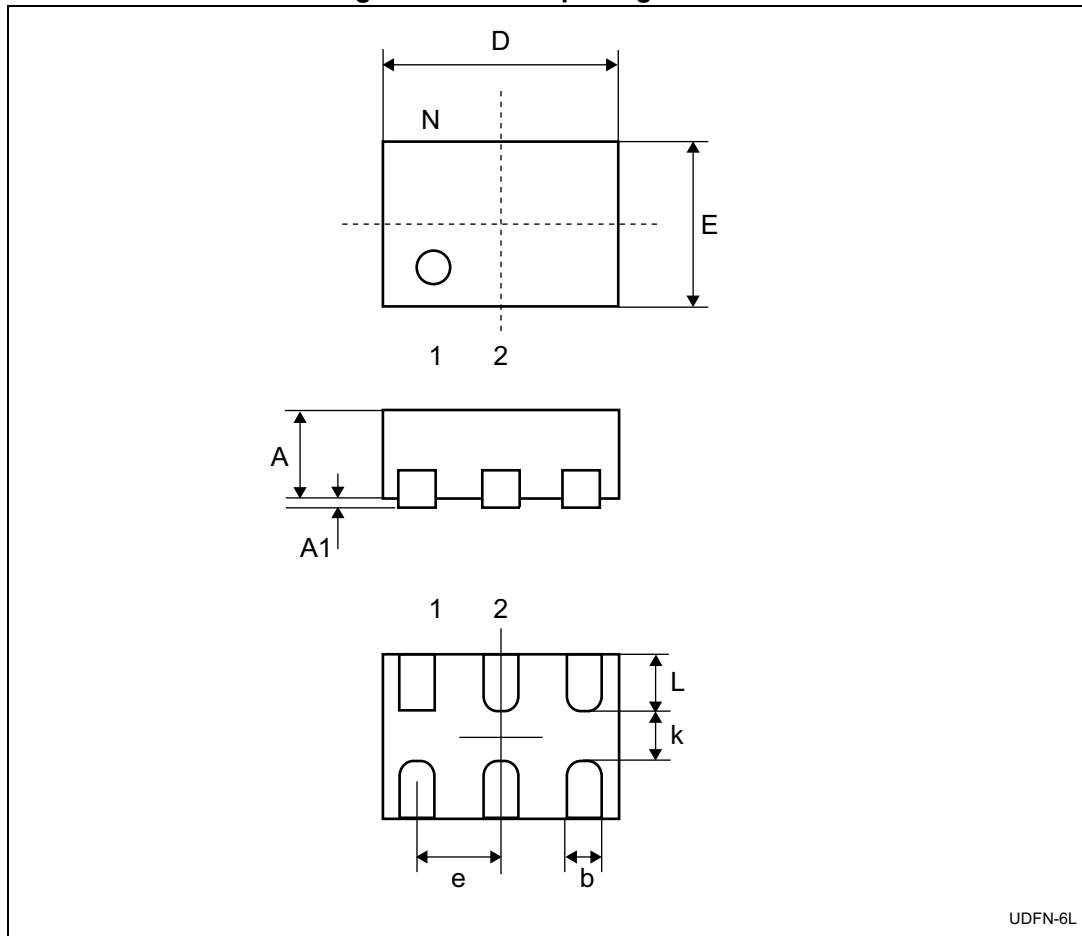
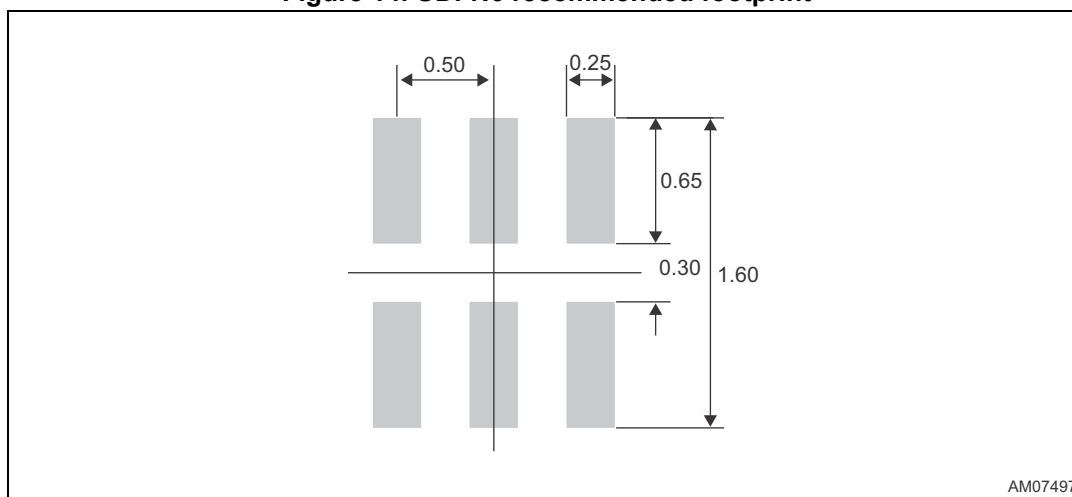

Table 5. UDFN6 mechanical data

Symbol	Dimensions						Note ⁽¹⁾
	(mm)			(inches)			
	Min.	Typ.	Max.	Min.	Typ.	Max.	
A	0.50	0.55	0.60	0.0197	0.0217	0.0236	
A1	0.00	0.02	0.05	0.000	0.0008	0.0020	
b	0.18	0.25	0.30	0.0071	0.0098	0.0118	
D	1.40	1.45	1.50	0.0551	0.0571	0.0591	
E	0.95	1.00	1.05	0.0374	0.0394	0.0413	
e	0.45	0.50	0.55	0.0177	0.0197	0.0217	
k	0.20			0.0079			
L	0.30	0.35	0.40	0.0118	0.0138	0.0157	

1. Package outline exclusive of any mold flashes dimensions and metal burrs.

Figure 14. UDFN6 recommended footprint



9.2 Tape and reel information

Figure 15. Carrier tape

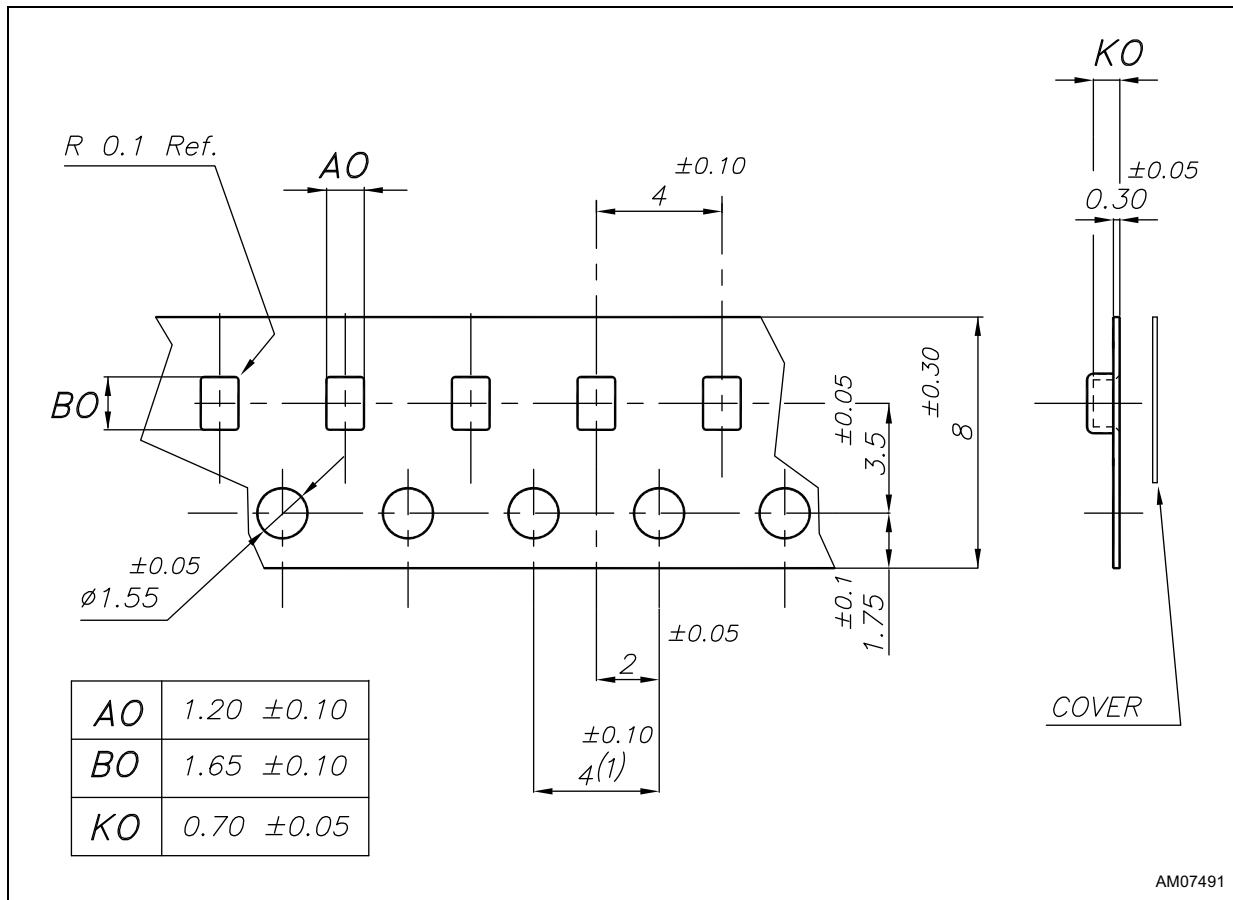
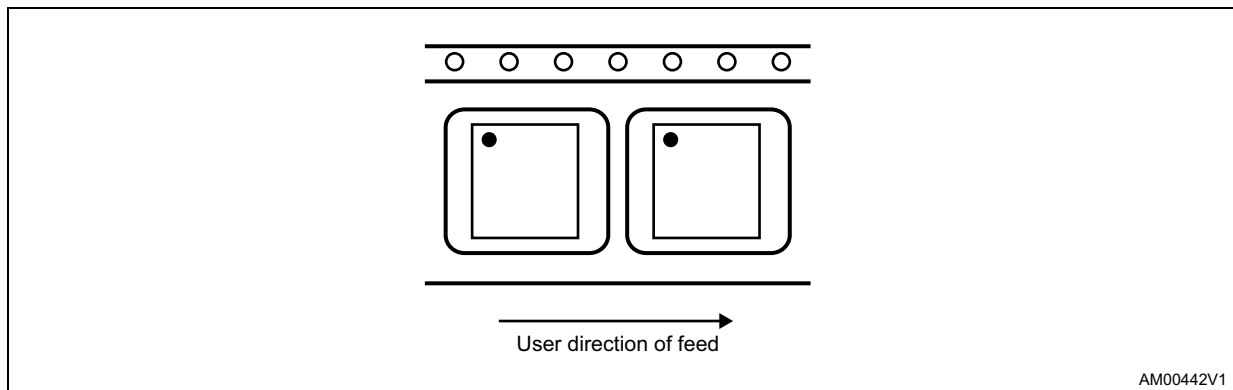

Figure 16. Pin 1 orientation



10 Part numbering

Table 6. Ordering information scheme

Example:	STM6519	A	H	A	R	UB	6	F
Device type	STM6519							
Reset (V_{CC} monitoring threshold) voltage V_{RST}	A = no V_{CC} monitoring feature							
Smart Reset setup delay (t_{SRC})⁽¹⁾	C = factory programmable $t_{SRC} = 1.5$ s (typ.) H = factory programmable $t_{SRC} = 4.0$ s (typ.) L = factory programmable $t_{SRC} = 6.0$ s (typ.) P = factory programmable $t_{SRC} = 7.5$ s (typ.) U = factory programmable $t_{SRC} = 10.0$ s (typ.)							
Inputs, outputs type⁽²⁾	A = active-low \overline{SR} input with no pull-up, active-low open drain \overline{RST} output with no pull-up B = active-low \overline{SR} input with pull-up, active-low open drain \overline{RST} output with no pull-up							
Reset timeout period (t_{REC})	A = factory programmable $t_{REC} = 210$ ms (typ.) B = factory programmable $t_{REC} = 360$ ms (typ.) E = factory programmable $t_{REC} = 1.28$ ms (typ.) F = factory programmable $t_{REC} = 100$ ms (typ.) R = push-button controlled (no defined t_{REC})							
Package	UB = UDFN-6L							
Temperature range	6 = -40 °C to 85 °C							
Shipping method	F = tape and reel							

- Smart Reset delay (t_{SRC}) is available from 0.5 s to 10 s in 0.5 s steps (typ.). Minimum order quantities may apply. Contact local sales office for availability.
- Push-pull reset output type also available (active-low or active-high). \overline{SR} input and open drain reset output available with optional pull-up resistor. Minimum order quantities may apply. Contact local sales office for availability.

11 Package marking information

Table 7. Package marking

Part number	t _{SRC} (s)	Smart Reset inputs ⁽¹⁾	Output type ⁽²⁾	t _{REC} option ⁽³⁾	Package	Topmark
STM6519ACARUB6F	1.5	AL	OD, AL	No t _{REC}	UDFN6	CA
STM6519AHARUB6F	4.0	AL	OD, AL	No t _{REC}	UDFN6	HA
STM6519ALARUB6F	6.0	AL	OD, AL	No t _{REC}	UDFN6	LA
STM6519APAAUB6F	7.5	AL	OD, AL	210 ms	UDFN6	PB
STM6519APARUB6F	7.5	AL	OD, AL	No t _{REC}	UDFN6	PA
STM6519APBBUB6F	7.5	AL + pull-up	OD, AL	360 ms	UDFN6	PC
STM6519AUARUB6F	10.0	AL	OD, AL	No t _{REC}	UDFN6	UA

1. AL = active-low.
2. OD = open drain, AL = active-low.
3. No t_{REC} = push-button controlled reset pulse width, any other value represents typical value of t_{REC}.

Figure 17. Package marking (top view)

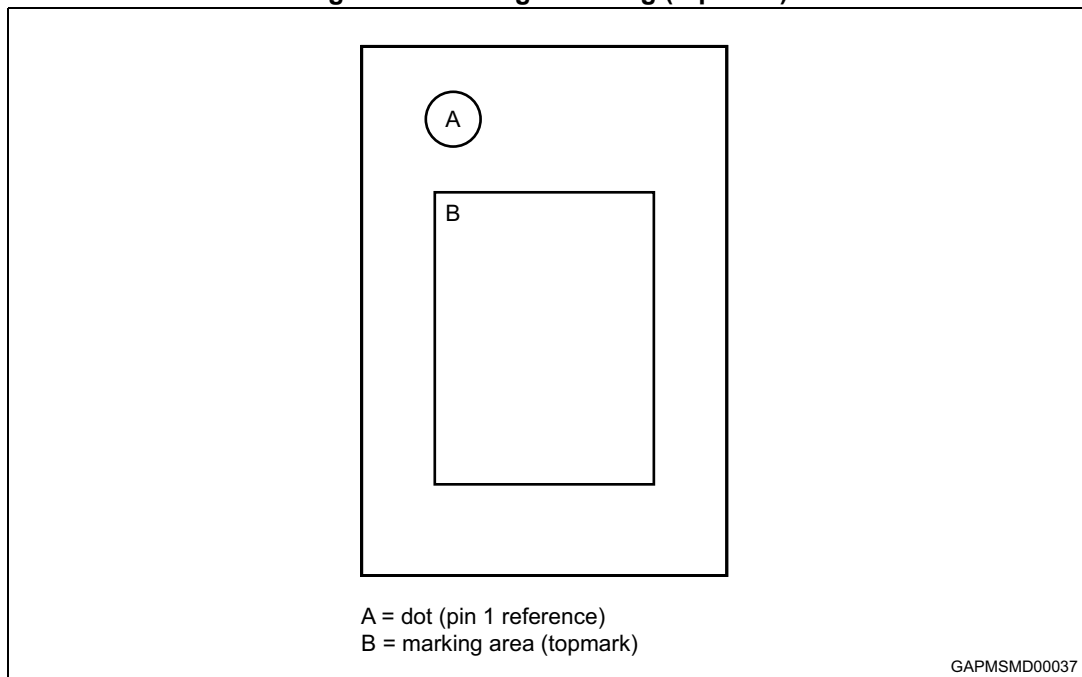

12 Revision history

Table 8. Document revision history

Date	Revision	Changes
12-Aug-2011	1	Initial release.
22-Sep-2011	2	Updated Figure 5, Table 4, Table 7 and Table 8.
07-Oct-2011	3	Removed label "Preliminary data".
27-Oct-2011	4	Updated Figure 3 and Table 1.
13-Jun-2012	5	Updated Features, Table 4, title of Section 9.
17-Jan-2013	6	Moved Figure 4 below Table 1. Added Section 3.2, Section 3.6, Figure 6 and Figure 7. Updated title of Figure 5. Updated Figure 8 and Figure 9 (added notes and minor modifications).
29-Jun-2016	7	Updated datasheet title Removed UDFN4 package from datasheet

IMPORTANT NOTICE – PLEASE READ CAREFULLY

STMicroelectronics NV and its subsidiaries ("ST") reserve the right to make changes, corrections, enhancements, modifications, and improvements to ST products and/or to this document at any time without notice. Purchasers should obtain the latest relevant information on ST products before placing orders. ST products are sold pursuant to ST's terms and conditions of sale in place at the time of order acknowledgement.

Purchasers are solely responsible for the choice, selection, and use of ST products and ST assumes no liability for application assistance or the design of Purchasers' products.

No license, express or implied, to any intellectual property right is granted by ST herein.

Resale of ST products with provisions different from the information set forth herein shall void any warranty granted by ST for such product.

ST and the ST logo are trademarks of ST. All other product or service names are the property of their respective owners.



Information in this document supersedes and replaces information previously supplied in any prior versions of this document.

© 2016 STMicroelectronics – All rights reserved



Looking for pricing, stock, or lifecycle information?

Click below to explore more details on WIN SOURCE:

-  [View STM6519ALARUB6F on WIN SOURCE](#)
-  [STMicroelectronics Information](#)

Optimize Your Supply Chain with WIN SOURCE Solutions

-  Global Sourcing Solution
-  Obsolete Management
-  Cost Control Management
-  Shortage Management
-  Alternative Solution
-  Excess Inventory Management