



**THE DATASHEET OF  
PS219B2-AS**



## SN74LVC2G66 Dual Bilateral Analog Switch

### 1 Features

- Available in the Texas Instruments NanoFree™ Package
- 1.65-V to 5.5-V  $V_{CC}$  Operation
- Inputs Accept Voltages to 5.5 V
- Max  $t_{pd}$  of 0.8 ns at 3.3 V
- High On-Off Output Voltage Ratio
- High Degree of Linearity
- High Speed, Typically 0.5 ns ( $V_{CC} = 3$  V,  $C_L = 50$  pF)
- Rail-to-Rail Input/Output
- Low ON-State Resistance, Typically  $\#6 \Omega$  ( $V_{CC} = 4.5$  V)
- Latch-Up Performance Exceeds 100 mA Per JESD 78, Class II

### 2 Applications

- Wireless Devices
- Audio and Video Signal Routing
- Portable Computing
- Wearable Devices
- Signal Gating, Chopping, Modulation or Demodulation (Modem)
- Signal Multiplexing for Analog-to-Digital and Digital-to-Analog Conversion Systems

### 3 Description

This dual bilateral analog switch is designed for 1.65-V to 5.5-V  $V_{CC}$  operation.

The SN74LVC2G66 device can handle both analog and digital signals. The SN74LVC2G66 device permits signals with amplitudes of up to 5.5 V (peak) to be transmitted in either direction.

NanoFree package technology is a major breakthrough in IC packaging concepts, using the die as the package.

Each switch section has its own enable-input control (C). A high-level voltage applied to C turns on the associated switch section.

Applications include signal gating, chopping, modulation or demodulation (modem), and signal multiplexing for analog-to-digital and digital-to-analog conversion systems.

#### Device Information<sup>(1)</sup>

PART NUMBER	PACKAGE	BODY SIZE (NOM)
SN74LVC2G66DCT	SSOP (8)	2.95 mm × 2.80 mm
SN74LVC2G66DCU	VSSOP (8)	2.30 mm × 2.00 mm
SN74LVC2G66YZP	DSBGA (8)	1.91 mm × 0.91 mm

(1) For all available packages, see the orderable addendum at the end of the data sheet.

#### Logic Diagram, Each Switch (Positive Logic)

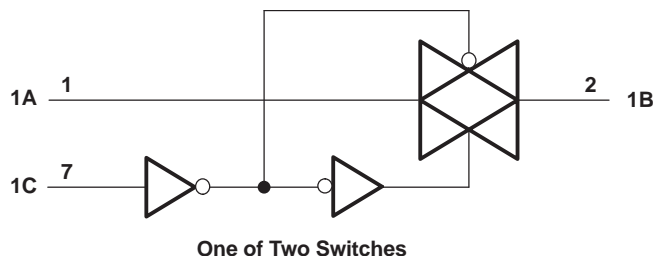

## Table of Contents

<b>1 Features</b> .....	<b>1</b>	8.1 Overview .....	<b>13</b>
<b>2 Applications</b> .....	<b>1</b>	8.2 Functional Block Diagram .....	<b>13</b>
<b>3 Description</b> .....	<b>1</b>	8.3 Feature Description .....	<b>13</b>
<b>4 Revision History</b> .....	<b>2</b>	8.4 Device Functional Modes .....	<b>13</b>
<b>5 Pin Configuration and Functions</b> .....	<b>3</b>	<b>9 Application and Implementation</b> .....	<b>14</b>
<b>6 Specifications</b> .....	<b>4</b>	9.1 Application Information .....	<b>14</b>
6.1 Absolute Maximum Ratings .....	<b>4</b>	9.2 Typical Application .....	<b>14</b>
6.2 ESD Ratings .....	<b>4</b>	<b>10 Power Supply Recommendations</b> .....	<b>15</b>
6.3 Recommended Operating Conditions .....	<b>4</b>	<b>11 Layout</b> .....	<b>16</b>
6.4 Thermal Information .....	<b>5</b>	11.1 Layout Guidelines .....	<b>16</b>
6.5 Electrical Characteristics .....	<b>5</b>	11.2 Layout Example .....	<b>16</b>
6.6 Switching Characteristics .....	<b>6</b>	<b>12 Device and Documentation Support</b> .....	<b>17</b>
6.7 Analog Switch Characteristics .....	<b>6</b>	12.1 Community Resources .....	<b>17</b>
6.8 Operating Characteristics .....	<b>7</b>	12.2 Trademarks .....	<b>17</b>
6.9 Typical Characteristics .....	<b>7</b>	12.3 Electrostatic Discharge Caution .....	<b>17</b>
<b>7 Parameter Measurement Information</b> .....	<b>8</b>	12.4 Glossary .....	<b>17</b>
<b>8 Detailed Description</b> .....	<b>13</b>	<b>13 Mechanical, Packaging, and Orderable Information</b> .....	<b>17</b>

## 4 Revision History

NOTE: Page numbers for previous revisions may differ from page numbers in the current version.

### Changes from Revision M (May 2018) to Revision N Page

- Changed the YZP pin configuration .....

**3**

### Changes from Revision L (September 2015) to Revision M Page

- Updated pinout image and the *Pin Function* table .....
- Changed pin 3 Name From: 1C To: 2C .....
- Changed the *Thermal Information* table for the DCT package .....

**3**

**3**

**5**

### Changes from Revision K (January 2014) to Revision L Page

- Added *Applications* section, *Device Information* table, *Pin Configuration and Functions* section, *ESD Ratings* table, *Typical Characteristics* section, *Feature Description* section, *Device Functional Modes*, *Application and Implementation* section, *Power Supply Recommendations* section, *Layout* section, *Device and Documentation Support* section, and *Mechanical, Packaging, and Orderable Information* section .....
- Added *Thermal Information* table .....

**1**

**5**

### Changes from Revision J (December 2011) to Revision K Page

- Updated document to new TI data sheet format--no specification changes. ....
- Removed *Ordering Information* table. ....

**1**

**1**

## 5 Pin Configuration and Functions

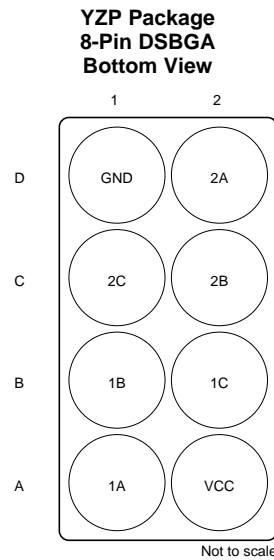
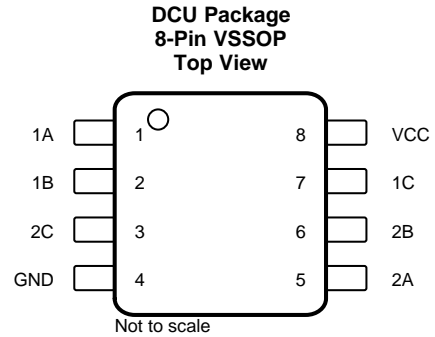
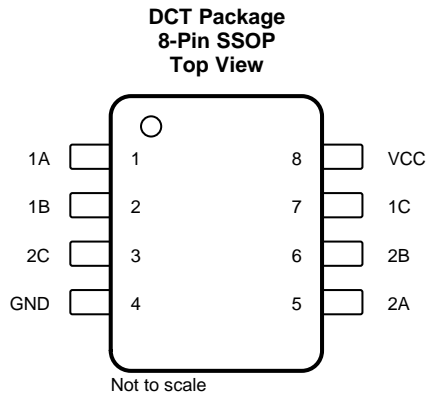

See mechanical drawings for dimensions.

### Pin Functions

NAME	PIN		I/O	DESCRIPTION
	DCT DCU	YZP		
1A	1	A1	I/O	Bidirectional signal to be switched
1B	2	B1	I/O	Bidirectional signal to be switched
2C	3	C1	I	Controls the switch (L = OFF, H = ON)
2A	5	D2	I/O	Bidirectional signal to be switched
2B	6	C2	I/O	Bidirectional signal to be switched
1C	7	B2	I	Controls the switch (L = OFF, H = ON)
GND	4	D1	—	Ground pin
V <sub>CC</sub>	8	A2	—	Power pin

## 6 Specifications

### 6.1 Absolute Maximum Ratings

 over operating free-air temperature range (unless otherwise noted)<sup>(1)</sup>

		MIN	MAX	UNIT
V <sub>CC</sub>	Supply voltage <sup>(2)</sup>	-0.5	6.5	V
V <sub>I</sub>	Input voltage <sup>(2)(3)</sup>	-0.5	6.5	V
V <sub>O</sub>	Switch I/O voltage <sup>(2)(3)(4)</sup>	-0.5	V <sub>CC</sub> + 0.5	V
I <sub>IK</sub>	Control input clamp current	V <sub>I</sub> < 0	-50	mA
I <sub>I/O</sub>	I/O port diode current	V <sub>I/O</sub> < 0 or V <sub>I/O</sub> > V <sub>CC</sub>	-50	mA
I <sub>T</sub>	On-state switch current	V <sub>I/O</sub> = 0 to V <sub>CC</sub>	±50	mA
Continuous current through V <sub>CC</sub> or GND			±100	mA
T <sub>stg</sub>	Storage temperature	-65	150	°C

- (1) Stresses beyond those listed under *Absolute Maximum Ratings* may cause permanent damage to the device. These are stress ratings only, and functional operation of the device at these or any other conditions beyond those indicated under *Recommended Operating Conditions* is not implied. Exposure to absolute-maximum-rated conditions for extended periods may affect device reliability.
- (2) All voltages are with respect to ground, unless otherwise specified.
- (3) The input and output negative-voltage ratings may be exceeded if the input and output clamp-current ratings are observed.
- (4) This value is limited to 5.5 V maximum.

### 6.2 ESD Ratings

		VALUE	UNIT
V <sub>(ESD)</sub>	Electrostatic discharge	Human body model (HBM), per ANSI/ESDA/JEDEC JS-001, all pins <sup>(1)</sup>	±2000
		Charged-device model (CDM), per JEDEC specification JESD22-C101, all pins <sup>(2)</sup>	±1000

- (1) JEDEC document JEP155 states that 500-V HBM allows safe manufacturing with a standard ESD control process.
- (2) JEDEC document JEP157 states that 250-V CDM allows safe manufacturing with a standard ESD control process.

### 6.3 Recommended Operating Conditions

 See <sup>(1)</sup>.

		MIN	MAX	UNIT
V <sub>CC</sub>	Supply voltage	1.65	5.5	V
V <sub>I/O</sub>	I/O port voltage	0	V <sub>CC</sub>	V
V <sub>IH</sub>	High-level input voltage, control input	V <sub>CC</sub> = 1.65 V to 1.95 V	V <sub>CC</sub> × 0.65	V
		V <sub>CC</sub> = 2.3 V to 2.7 V	V <sub>CC</sub> × 0.7	
		V <sub>CC</sub> = 3 V to 3.6 V	V <sub>CC</sub> × 0.7	
		V <sub>CC</sub> = 4.5 V to 5.5 V	V <sub>CC</sub> × 0.7	
V <sub>IL</sub>	Low-level input voltage, control input	V <sub>CC</sub> = 1.65 V to 1.95 V	V <sub>CC</sub> × 0.35	V
		V <sub>CC</sub> = 2.3 V to 2.7 V	V <sub>CC</sub> × 0.3	
		V <sub>CC</sub> = 3 V to 3.6 V	V <sub>CC</sub> × 0.3	
		V <sub>CC</sub> = 4.5 V to 5.5 V	V <sub>CC</sub> × 0.3	
V <sub>I</sub>	Control input voltage	0	5.5	V
Δt/Δv	Input transition rise or fall time	V <sub>CC</sub> = 1.65 V to 1.95 V	20	ns/V
		V <sub>CC</sub> = 2.3 V to 2.7 V	20	
		V <sub>CC</sub> = 3 V to 3.6 V	10	
		V <sub>CC</sub> = 4.5 V to 5.5 V	10	
T <sub>A</sub>	Operating free-air temperature	-40	85	°C

- (1) All unused inputs of the device must be held at V<sub>CC</sub> or GND to ensure proper device operation. Refer to the TI application report, *Implications of Slow or Floating CMOS Inputs*, [SCBA004](#).

## 6.4 Thermal Information

THERMAL METRIC <sup>(1)</sup>		SN74LVC2G66			UNIT
		DCT (SSOP)	DCU (VSSOP)	YZP (DSBGA)	
		8 PINS	8 PINS	8 PINS	
R <sub>θJA</sub>	Junction-to-ambient thermal resistance	186.1	204.4	102	°C/W
R <sub>θJC(top)</sub>	Junction-to-case (top) thermal resistance	116.5	77	—	°C/W
R <sub>θJB</sub>	Junction-to-board thermal resistance	98.6	83.2	—	°C/W
ψ <sub>JT</sub>	Junction-to-top characterization parameter	42.2	7.1	—	°C/W
ψ <sub>JB</sub>	Junction-to-board characterization parameter	97.6	82.7	—	°C/W
R <sub>θJC(bot)</sub>	Junction-to-case (bottom) thermal resistance	n/a	n/a	—	°C/W

(1) For more information about traditional and new thermal metrics, see the [Semiconductor and IC Package Thermal Metrics](#) application report.

## 6.5 Electrical Characteristics

over recommended operating free-air temperature range (unless otherwise noted)

PARAMETER	TEST CONDITIONS	V <sub>CC</sub>	MIN TYP <sup>(1)</sup> MAX			UNIT
r <sub>on</sub>	V <sub>I</sub> = V <sub>CC</sub> or GND, V <sub>C</sub> = V <sub>IH</sub> (see <a href="#">Figure 3</a> and <a href="#">Figure 1</a> )	I <sub>S</sub> = 4 mA	1.65 V	12.5	30	Ω
			2.3 V	9	20	
			3 V	7.5	15	
			4.5 V	6	10	
r <sub>on(p)</sub>	V <sub>I</sub> = V <sub>CC</sub> to GND, V <sub>C</sub> = V <sub>IH</sub> (see <a href="#">Figure 3</a> and <a href="#">Figure 1</a> )	I <sub>S</sub> = 4 mA	1.65 V	85	120 <sup>(1)</sup>	Ω
			2.3 V	22	30 <sup>(1)</sup>	
			3 V	12	20	
			4.5 V	7.5	15	
Δr <sub>on</sub>	V <sub>I</sub> = V <sub>CC</sub> to GND, V <sub>C</sub> = V <sub>IH</sub> (see <a href="#">Figure 3</a> and <a href="#">Figure 1</a> )	I <sub>S</sub> = 4 mA	1.65 V		7	Ω
			2.3 V		5	
			3 V		3	
			4.5 V		2	
I <sub>S(off)</sub>	V <sub>I</sub> = V <sub>CC</sub> and V <sub>O</sub> = GND or V <sub>I</sub> = GND and V <sub>O</sub> = V <sub>CC</sub> , V <sub>C</sub> = V <sub>IL</sub> (see <a href="#">Figure 4</a> )	5.5 V		±1	μA	
I <sub>S(on)</sub>	V <sub>I</sub> = V <sub>CC</sub> or GND, V <sub>C</sub> = V <sub>IH</sub> , V <sub>O</sub> = Open (see <a href="#">Figure 5</a> )	5.5 V		±1	μA	
I <sub>I</sub>	V <sub>C</sub> = V <sub>CC</sub> or GND	5.5 V		±1	μA	
I <sub>CC</sub>	V <sub>C</sub> = V <sub>CC</sub> or GND	5.5 V		10	μA	
ΔI <sub>CC</sub>	V <sub>C</sub> = V <sub>CC</sub> – 0.6 V	5.5 V		500	μA	
C <sub>ic</sub>		5 V		3.5	pF	
C <sub>io(off)</sub>		5 V		6	pF	
C <sub>io(on)</sub>		5 V		14	pF	

(1) T<sub>A</sub> = 25°C

## 6.6 Switching Characteristics

 over recommended operating free-air temperature range (unless otherwise noted) (see [Figure 2](#))

PARAMETER	FROM (INPUT)	TO (OUTPUT)	$V_{CC} = 1.8\text{ V} \pm 0.15\text{ V}$		$V_{CC} = 2.5\text{ V} \pm 0.2\text{ V}$		$V_{CC} = 3.3\text{ V} \pm 0.3\text{ V}$		$V_{CC} = 5\text{ V} \pm 0.5\text{ V}$		UNIT
			MIN	MAX	MIN	MAX	MIN	MAX	MIN	MAX	
$t_{pd}^{(1)}$	A or B	B or A		2		1.2		0.8		0.6	ns
$t_{en}^{(2)}$	C	A or B	2.3	10	1.6	5.6	1.5	4.4	1.3	3.9	ns
$t_{dis}^{(3)}$	C	A or B	2.5	10.5	1.2	6.9	2	7.2	1.1	6.3	ns

(1)  $t_{PLH}$  and  $t_{PHL}$  are the same as  $t_{pd}$ . The propagation delay is the calculated RC time constant of the typical on-state resistance of the switch and the specified load capacitance, when driven by an ideal voltage source (zero output impedance).

(2)  $t_{PZL}$  and  $t_{PZH}$  are the same as  $t_{en}$ .

(3)  $t_{PLZ}$  and  $t_{PHZ}$  are the same as  $t_{dis}$ .

## 6.7 Analog Switch Characteristics

 $T_A = 25^\circ\text{C}$ 

PARAMETER	FROM (INPUT)	TO (OUTPUT)	TEST CONDITIONS	$V_{CC}$	TYP	UNIT
Frequency response (switch on)	A or B	B or A	$C_L = 50\text{ pF}$ , $R_L = 600\ \Omega$ , $f_{in} = \text{sine wave}$ (see <a href="#">Figure 6</a> )	1.65 V	35	MHz
				2.3 V	120	
				3 V	175	
				4.5 V	195	
			$C_L = 5\text{ pF}$ , $R_L = 50\ \Omega$ , $f_{in} = \text{sine wave}$ (see <a href="#">Figure 6</a> )	1.65 V	>300	
				2.3 V	>300	
				3 V	>300	
				4.5 V	>300	
Crosstalk <sup>(1)</sup> (between switches)	A or B	B or A	$C_L = 50\text{ pF}$ , $R_L = 600\ \Omega$ , $f_{in} = 1\text{ MHz}$ (sine wave) (see <a href="#">Figure 7</a> )	1.65 V	-58	dB
				2.3 V	-58	
				3 V	-58	
				4.5 V	-58	
			$C_L = 5\text{ pF}$ , $R_L = 50\ \Omega$ , $f_{in} = 1\text{ MHz}$ (sine wave) (see <a href="#">Figure 7</a> )	1.65 V	-42	
				2.3 V	-42	
				3 V	-42	
				4.5 V	-42	
Crosstalk (control input to signal output)	C	A or B	$C_L = 50\text{ pF}$ , $R_L = 600\ \Omega$ , $f_{in} = 1\text{ MHz}$ (square wave) (see <a href="#">Figure 8</a> )	1.65 V	35	mV
				2.3 V	50	
				3 V	70	
				4.5 V	100	
Feedthrough attenuation (switch off)	A or B	B or A	$C_L = 50\text{ pF}$ , $R_L = 600\ \Omega$ , $f_{in} = 1\text{ MHz}$ (sine wave) (see <a href="#">Figure 9</a> )	1.65 V	-58	dB
				2.3 V	-58	
				3 V	-58	
				4.5 V	-58	
			$C_L = 5\text{ pF}$ , $R_L = 50\ \Omega$ , $f_{in} = 1\text{ MHz}$ (sine wave) (see <a href="#">Figure 9</a> )	1.65 V	-42	
				2.3 V	-42	
				3 V	-42	
				4.5 V	-42	

(1) Adjust  $f_{in}$  voltage to obtain 0 dBm at input.

### Analog Switch Characteristics (continued)

T<sub>A</sub> = 25°C

PARAMETER	FROM (INPUT)	TO (OUTPUT)	TEST CONDITIONS	V <sub>CC</sub>	TYP	UNIT
Sine-wave distortion	A or B	B or A	C <sub>L</sub> = 50 pF, R <sub>L</sub> = 10 kΩ, f <sub>in</sub> = 1 kHz (sine wave) (see Figure 10)	1.65 V	0.1%	
				2.3 V	0.025%	
				3 V	0.015%	
				4.5 V	0.01%	
			C <sub>L</sub> = 50 pF, R <sub>L</sub> = 10 kΩ, f <sub>in</sub> = 10 kHz (sine wave) (see Figure 10)	1.65 V	0.15%	
				2.3 V	0.025%	
				3 V	0.015%	
				4.5 V	0.01%	

### 6.8 Operating Characteristics

T<sub>A</sub> = 25°C

PARAMETER	TEST CONDITIONS	V <sub>CC</sub> = 1.8 V	V <sub>CC</sub> = 2.5 V	V <sub>CC</sub> = 3.3 V	V <sub>CC</sub> = 5 V	UNIT
		TYP	TYP	TYP	TYP	
C <sub>pd</sub> Power dissipation capacitance	f = 10 MHz	8	9	9.5	11	pF

### 6.9 Typical Characteristics

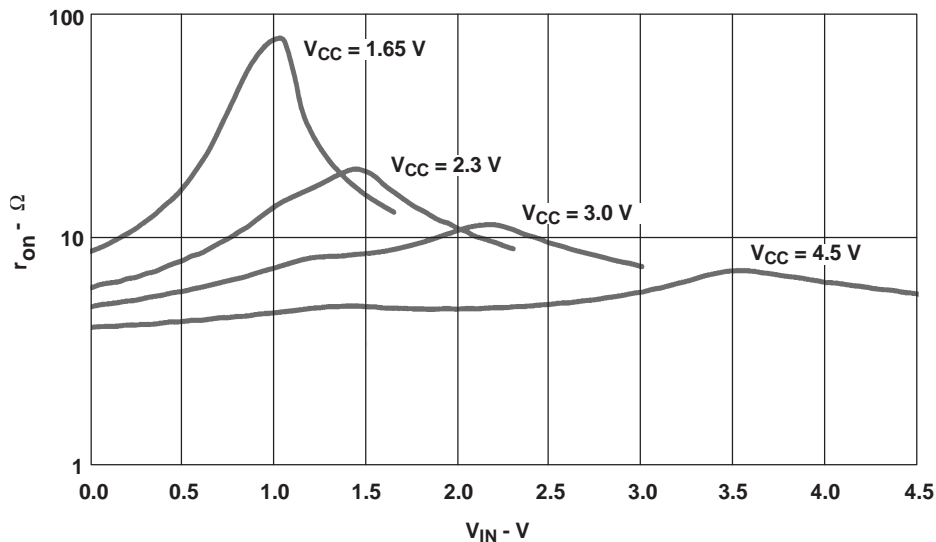
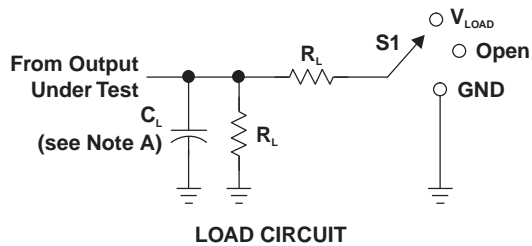

Figure 1. Typical r<sub>on</sub> as a Function of Input Voltage (V<sub>I</sub>) for V<sub>I</sub> = 0 to V<sub>CC</sub>

## 7 Parameter Measurement Information



TEST	S1
$t_{PLH}/t_{PHL}$	Open
$t_{PLZ}/t_{PZL}$	$V_{LOAD}$
$t_{PHZ}/t_{PZH}$	GND

$V_{CC}$	INPUTS		$V_M$	$V_{LOAD}$	$C_L$	$R_L$	$V_{\Delta}$
	$V_i$	$t_r/t_f$					
$1.8\text{ V} \pm 0.15\text{ V}$	$V_{CC}$	$\leq 2\text{ ns}$	$V_{CC}/2$	$2 \times V_{CC}$	30 pF	1 k $\Omega$	0.15 V
$2.5\text{ V} \pm 0.2\text{ V}$	$V_{CC}$	$\leq 2\text{ ns}$	$V_{CC}/2$	$2 \times V_{CC}$	30 pF	500 $\Omega$	0.15 V
$3.3\text{ V} \pm 0.3\text{ V}$	$V_{CC}$	$\leq 2.5\text{ ns}$	$V_{CC}/2$	$2 \times V_{CC}$	50 pF	500 $\Omega$	0.3 V
$5\text{ V} \pm 0.5\text{ V}$	$V_{CC}$	$\leq 2.5\text{ ns}$	$V_{CC}/2$	$2 \times V_{CC}$	50 pF	500 $\Omega$	0.3 V

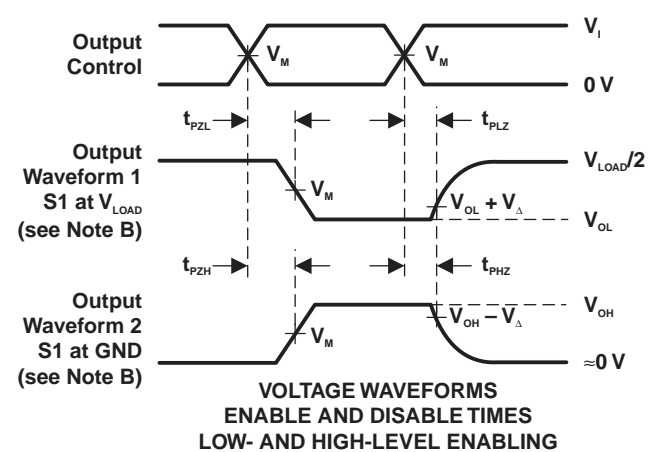
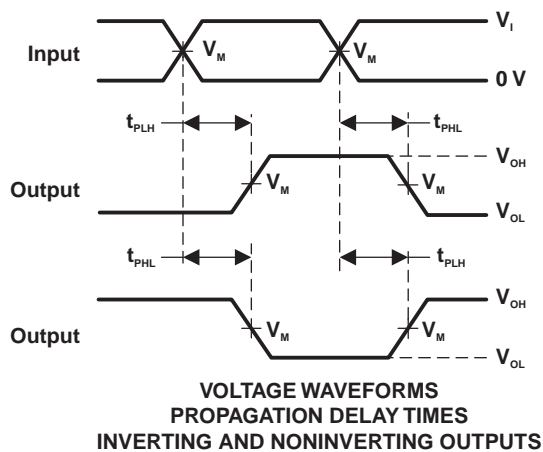
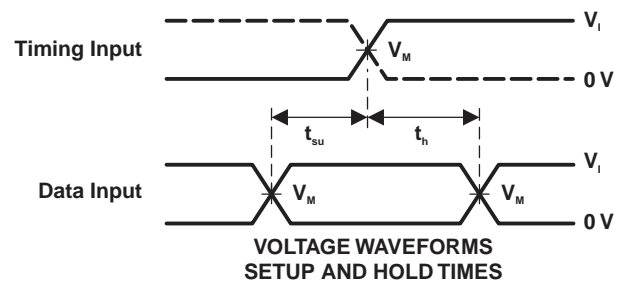
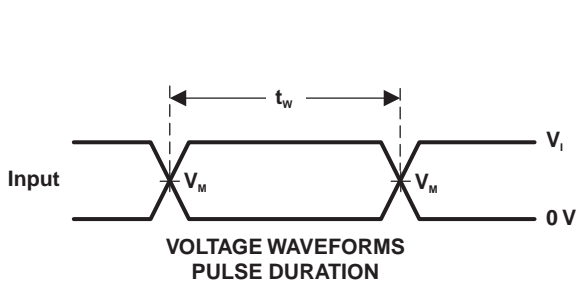

- NOTES:
- $C_L$  includes probe and jig capacitance.
  - Waveform 1 is for an output with internal conditions such that the output is low, except when disabled by the output control. Waveform 2 is for an output with internal conditions such that the output is high, except when disabled by the output control.
  - All input pulses are supplied by generators have the following characteristics:  $PRR \leq 10\text{ MHz}$ ,  $Z_o = 50\ \Omega$ .
  - The outputs are measured one at a time, with one transition per measurement.
  - $t_{PLZ}$  and  $t_{PHZ}$  are the same as  $t_{dis}$ .
  - $t_{PZL}$  and  $t_{PZH}$  are the same as  $t_{en}$ .
  - $t_{PLH}$  and  $t_{PHL}$  are the same as  $t_{pd}$ .
  - All parameters and waveforms are not applicable to all devices.

**Figure 2. Load Circuit and Voltage Waveforms**

Parameter Measurement Information (continued)

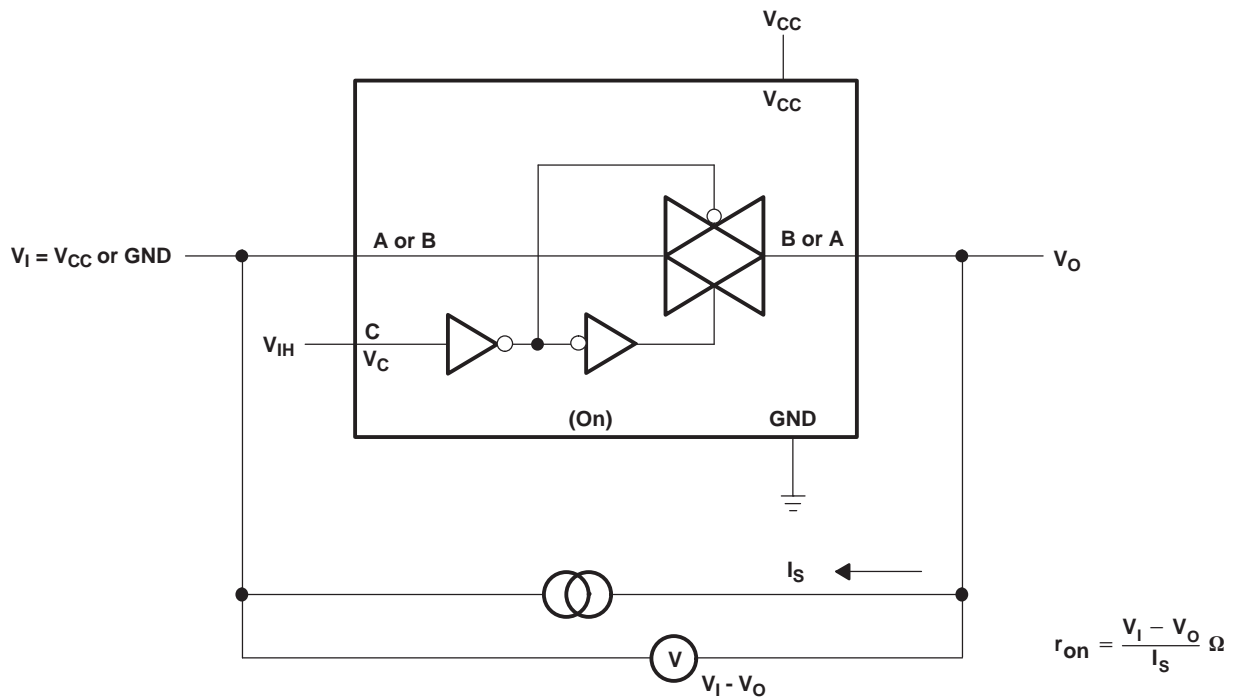

Figure 3. ON-State Resistance Test Circuit

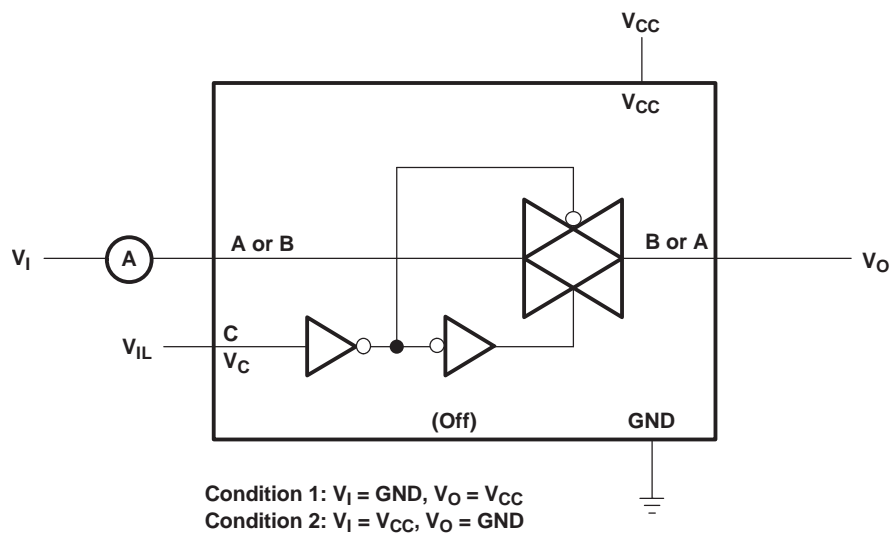

Figure 4. OFF-State Switch Leakage-Current Test Circuit

Parameter Measurement Information (continued)

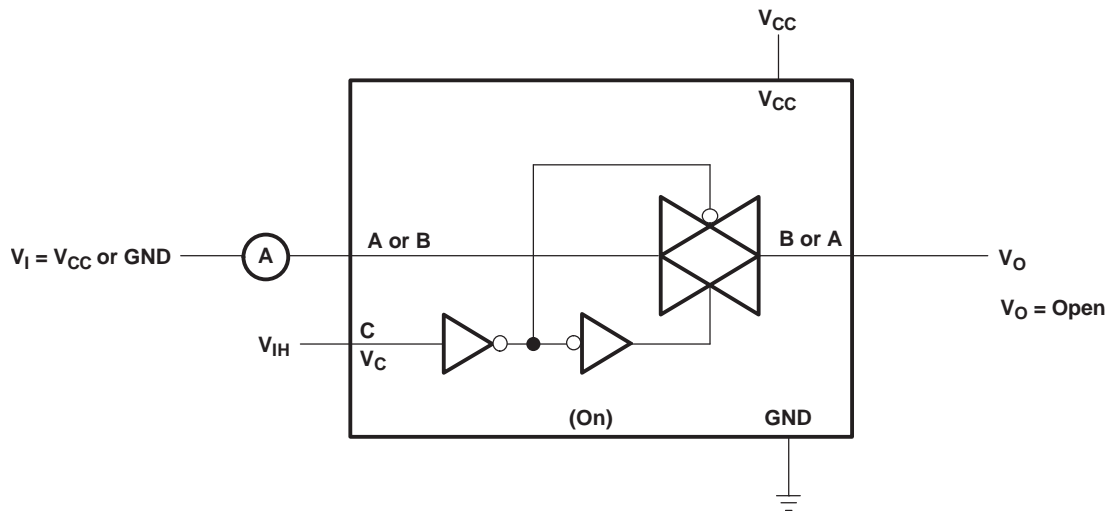

Figure 5. ON-State Leakage-Current Test Circuit

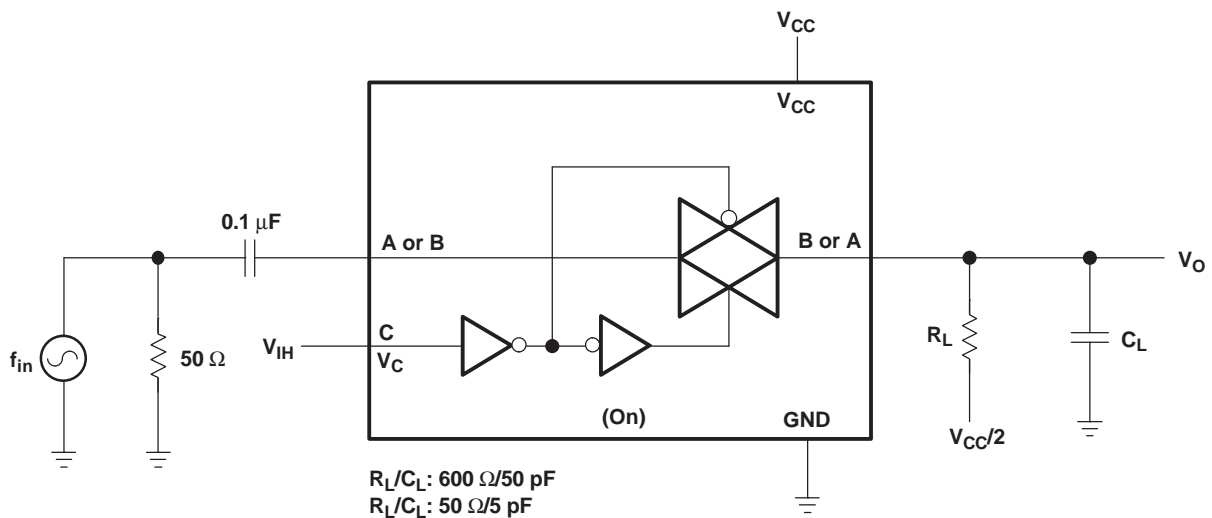

Figure 6. Frequency Response (Switch On)

Parameter Measurement Information (continued)

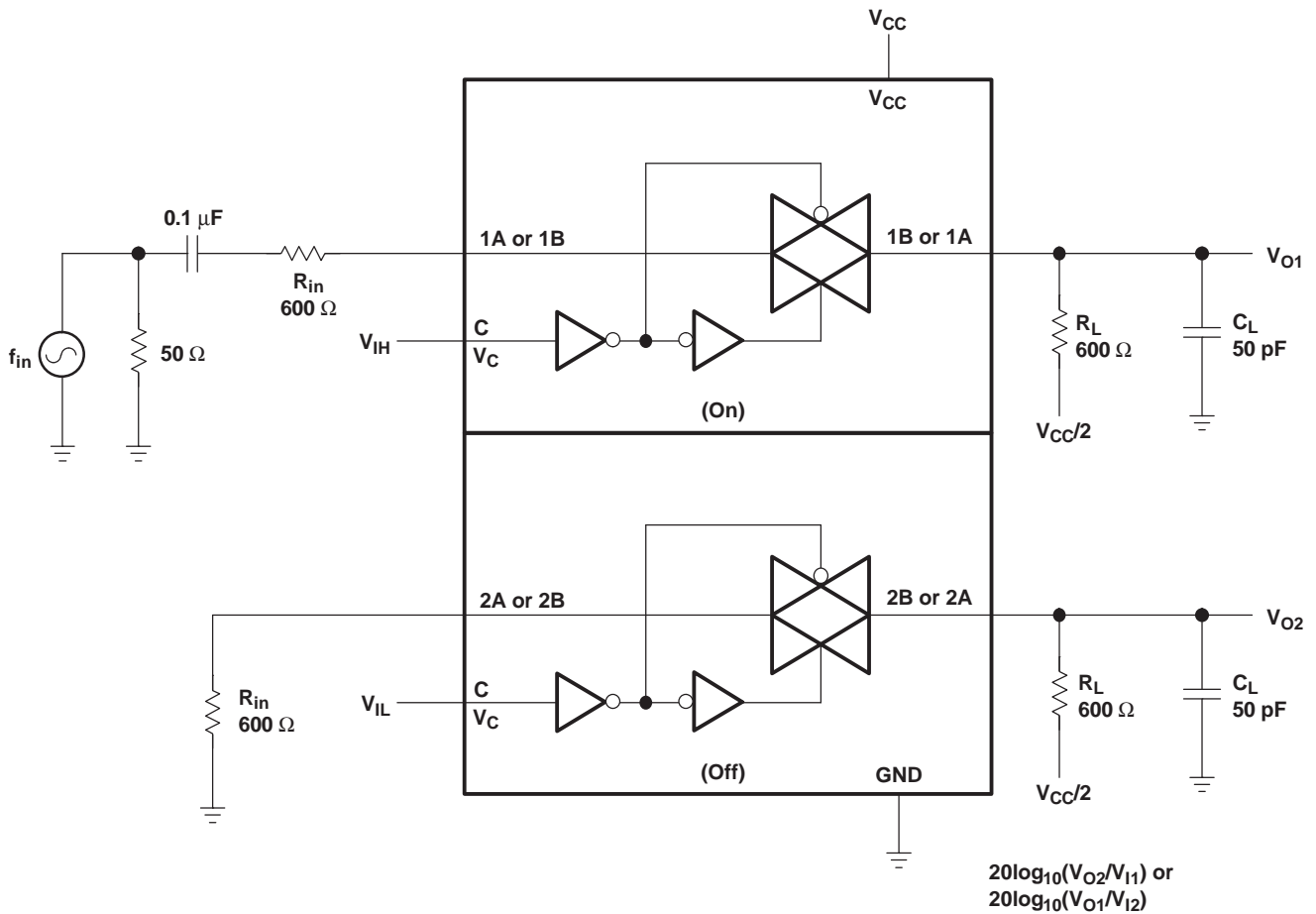

Figure 7. Crosstalk (Between Switches)

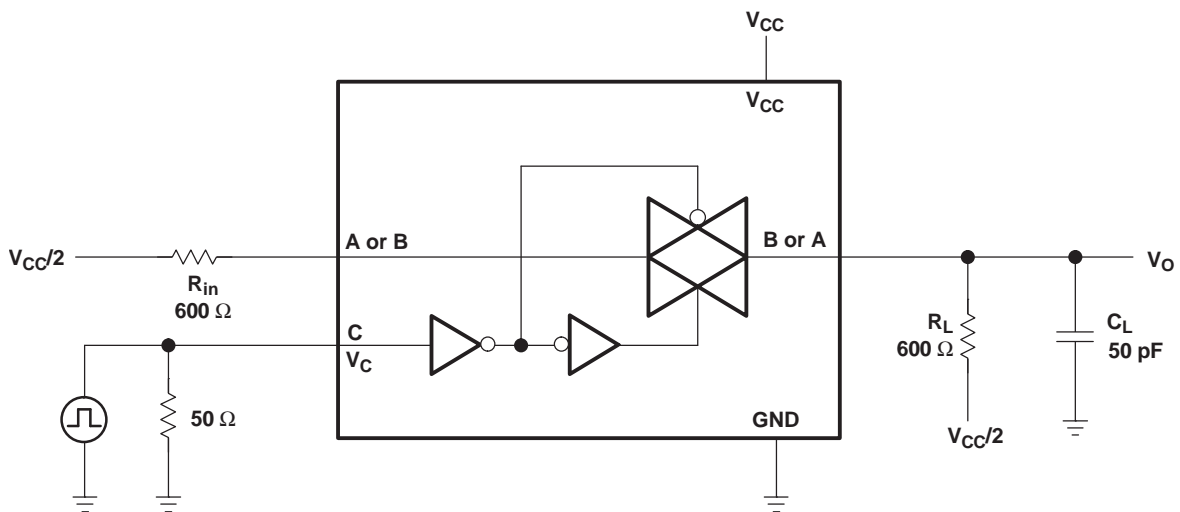

Figure 8. Crosstalk (Control Input, Switch Output)

Parameter Measurement Information (continued)

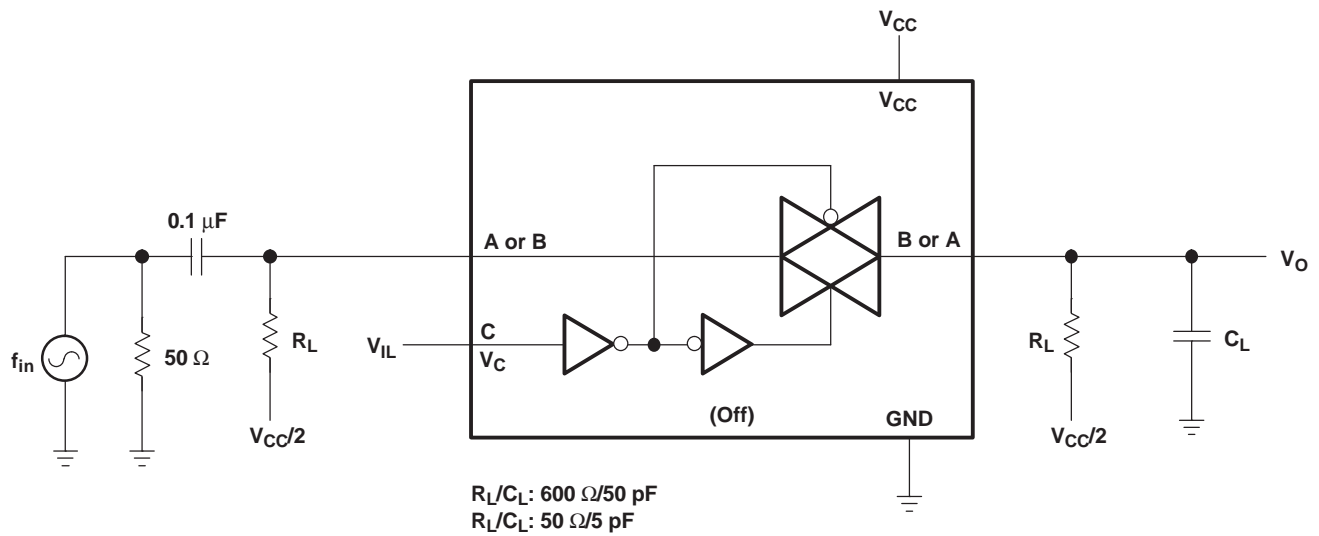

Figure 9. Feedthrough (Switch Off)

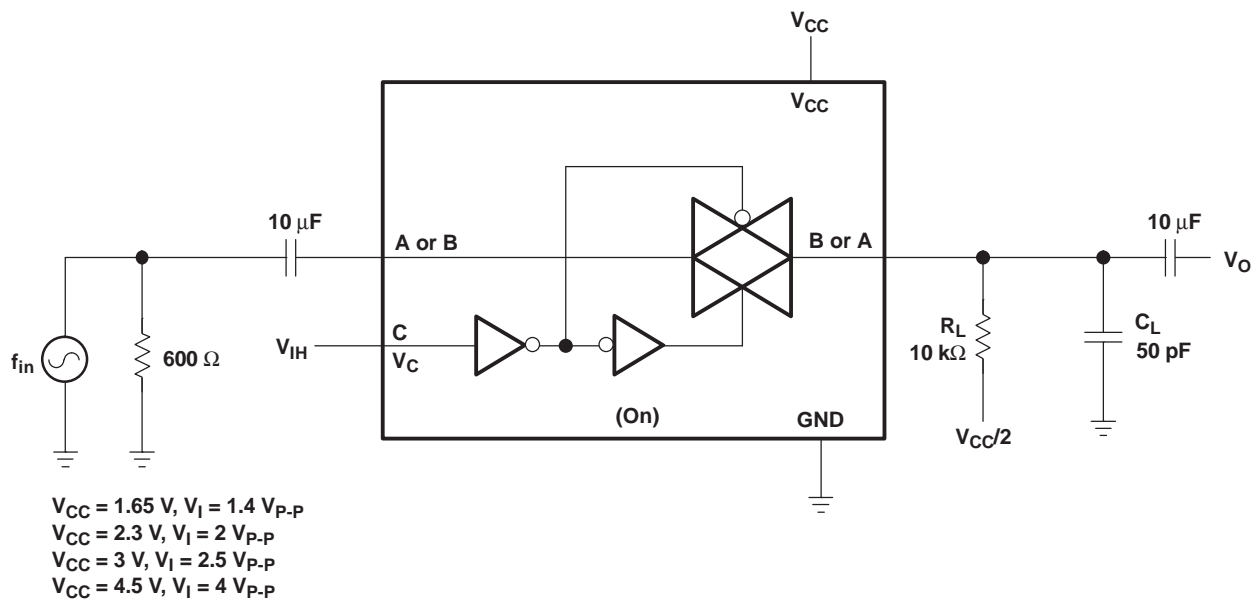

Figure 10. Sine-Wave Distortion

## 8 Detailed Description

### 8.1 Overview

This dual bilateral analog switch is designed for 1.65-V to 5.5-V  $V_{CC}$  operation. Robust LVC family technology allows this device to accept input voltages without connecting power to  $V_{CC}$ .

The SN74LVC2G66 device permits signals with amplitudes of up to 5.5 V (peak) to be transmitted in either direction. A high-level voltage applied to the control pin C enables the respective switch to begin propagating signals across the device. A low-level voltage disables this transmission. Each device incorporates two switches with independent control and operation.

### 8.2 Functional Block Diagram

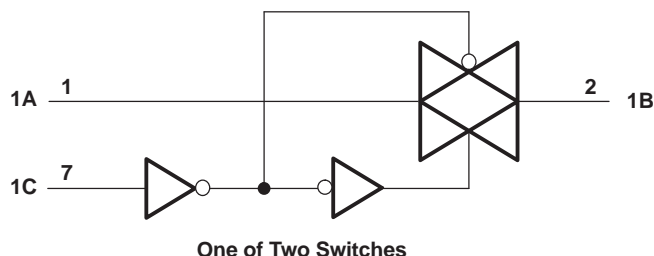

### 8.3 Feature Description

Each switch section has its own enable-input control (C). A high-level voltage applied to C turns on the associated switch section. When C is this Signals can pass through A to B or B to A. Low ON-resistance of 6  $\Omega$  at 4.5-V  $V_{CC}$  is ideal for analog signal conditioning systems. The control signals can accept voltages up to 5.5 V without  $V_{CC}$  connected in the system. Combination of lower  $t_{pd}$  of 0.8 ns at 3.3 V and low enable and disable time make this part suitable for high-speed signal switching applications.

### 8.4 Device Functional Modes

Table 1 lists the functional modes of the SN74LVC2G66.

**Table 1. Function Table**

CONTROL INPUT (C)	SWITCH
L	Off
H	On

## 9 Application and Implementation

### NOTE

Information in the following applications sections is not part of the TI component specification, and TI does not warrant its accuracy or completeness. TI's customers are responsible for determining suitability of components for their purposes. Customers should validate and test their design implementation to confirm system functionality.

### 9.1 Application Information

The SN74LVC2G66 can be used in any situation where an Dual SPST switch would be used and a solid-state, voltage controlled version is preferred.

### 9.2 Typical Application

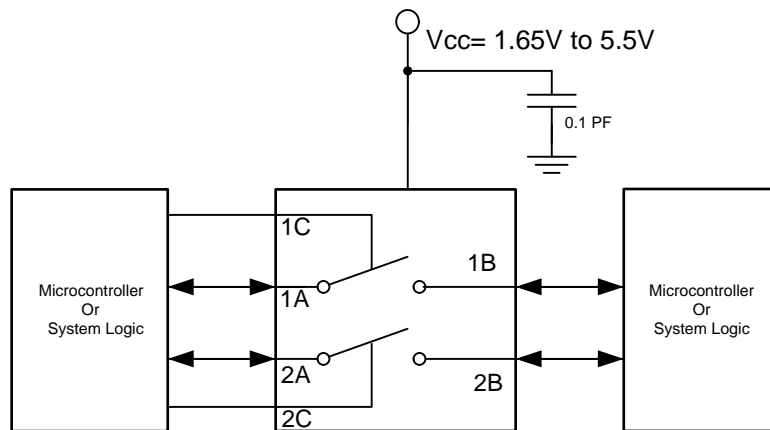

Copyright © 2016, Texas Instruments Incorporated

**Figure 11. Typical Application Schematic**

#### 9.2.1 Design Requirements

The SN74LVC2G66 allows on/off control of analog and digital signals with a digital control signal. All input signals should remain between 0 V and  $V_{CC}$  for optimal operation.

#### 9.2.2 Detailed Design Procedure

1. Recommended Input Conditions:
  - For rise time and fall time specifications, see  $\Delta t/\Delta v$  in the [Recommended Operating Conditions](#) table.
  - For specified high and low levels, see  $V_{IH}$  and  $V_{IL}$  in the [Recommended Operating Conditions](#) table.
  - Inputs and outputs are overvoltage tolerant allowing them to go as high as 5.5 V at any valid  $V_{CC}$ .
2. Recommended Output Conditions:
  - Load currents should not exceed  $\pm 50$  mA.
3. Frequency Selection Criterion:
  - Maximum frequency tested is 150 MHz.
  - Added trace resistance or capacitance can reduce maximum frequency capability; use layout practices as directed in [Layout](#).

## Typical Application (continued)

### 9.2.3 Application Curve

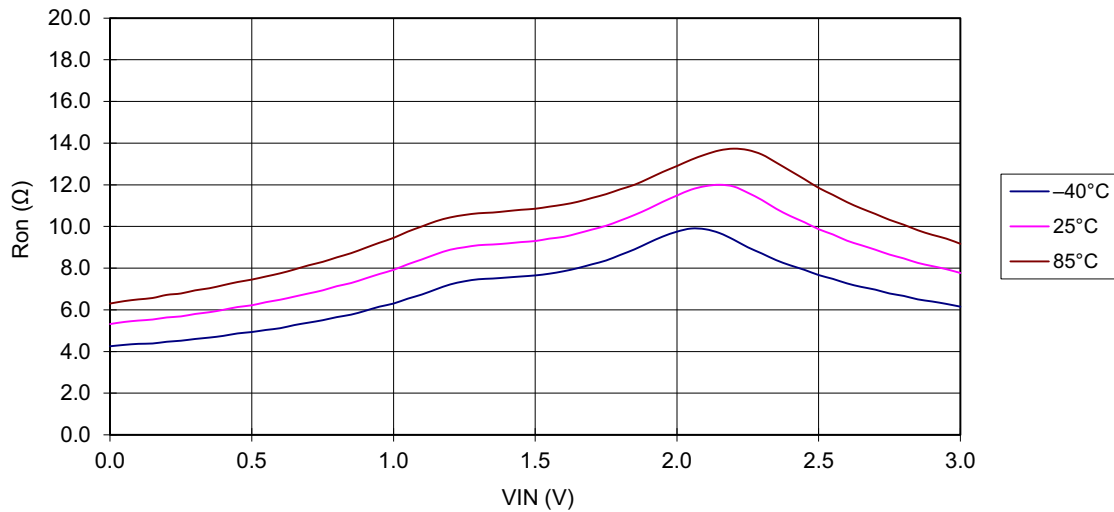

Pin: A–B,  $V_{CC} = 3\text{ V}$ ,  $I_S = 24\text{ mA}$

Figure 12.  $r_{on}$  vs  $V_I$

## 10 Power Supply Recommendations

The power supply can be any voltage between the minimum and maximum supply voltage rating located in the [Recommended Operating Conditions](#).

Each  $V_{CC}$  terminal should have a good bypass capacitor to prevent power disturbance. For devices with a single supply, a 0.1- $\mu\text{F}$  bypass capacitor is recommended. If there are multiple pins labeled  $V_{CC}$ , then a 0.01- $\mu\text{F}$  or 0.022- $\mu\text{F}$  capacitor is recommended for each  $V_{CC}$  because the VCC pins will be tied together internally. For devices with dual-supply pins operating at different voltages, for example  $V_{CC}$  and  $V_{DD}$ , a 0.1- $\mu\text{F}$  bypass capacitor is recommended for each supply pin. It is acceptable to parallel multiple bypass capacitors to reject different frequencies of noise. 0.1- $\mu\text{F}$  and 1- $\mu\text{F}$  capacitors are commonly used in parallel. The bypass capacitor should be installed as close to the power terminal as possible for best results.

## 11 Layout

### 11.1 Layout Guidelines

Reflections and matching are closely related to loop antenna theory, but different enough to warrant their own discussion. When a PCB trace turns a corner at a 90° angle, a reflection can occur. This is primarily due to the change of width of the trace. At the apex of the turn, the trace width is increased to 1.414 times its width. This upsets the transmission line characteristics, especially the distributed capacitance and self-inductance of the trace — resulting in the reflection.

**NOTE**

Not all PCB traces can be straight, and so they will have to turn corners. [Figure 13](#) shows progressively better techniques of rounding corners. Only the last example maintains constant trace width and minimizes reflections.

### 11.2 Layout Example

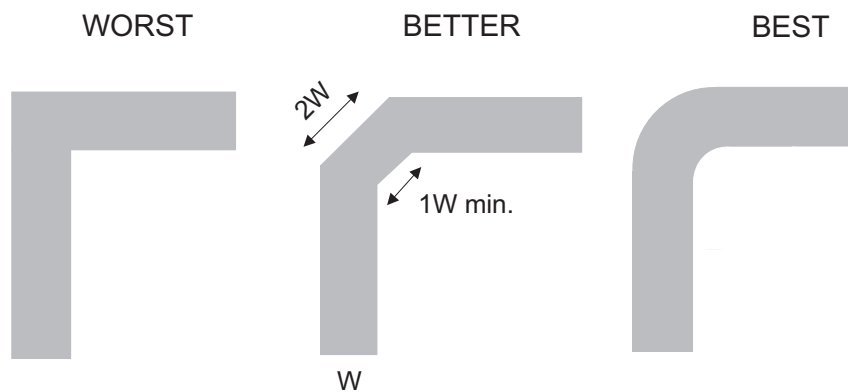

Figure 13. Trace Example

## 12 Device and Documentation Support

### 12.1 Community Resources

The following links connect to TI community resources. Linked contents are provided "AS IS" by the respective contributors. They do not constitute TI specifications and do not necessarily reflect TI's views; see TI's [Terms of Use](#).

**TI E2E™ Online Community** *TI's Engineer-to-Engineer (E2E) Community*. Created to foster collaboration among engineers. At [e2e.ti.com](http://e2e.ti.com), you can ask questions, share knowledge, explore ideas and help solve problems with fellow engineers.

**Design Support** *TI's Design Support* Quickly find helpful E2E forums along with design support tools and contact information for technical support.

### 12.2 Trademarks

NanoFree, E2E are trademarks of Texas Instruments.  
All other trademarks are the property of their respective owners.

### 12.3 Electrostatic Discharge Caution



These devices have limited built-in ESD protection. The leads should be shorted together or the device placed in conductive foam during storage or handling to prevent electrostatic damage to the MOS gates.

### 12.4 Glossary

[SLYZ022](#) — *TI Glossary*.

This glossary lists and explains terms, acronyms, and definitions.

## 13 Mechanical, Packaging, and Orderable Information

The following pages include mechanical, packaging, and orderable information. This information is the most current data available for the designated devices. This data is subject to change without notice and revision of this document. For browser-based versions of this data sheet, refer to the left-hand navigation.

**PACKAGING INFORMATION**

Orderable Device	Status (1)	Package Type	Package Drawing	Pins	Package Qty	Eco Plan (2)	Lead finish/ Ball material (6)	MSL Peak Temp (3)	Op Temp (°C)	Device Marking (4/5)	Samples
SN74LVC2G66DCTR	ACTIVE	SM8	DCT	8	3000	RoHS & Green	NIPDAU	Level-1-260C-UNLIM	-40 to 85	C66 (R, Z)	<a href="#">Samples</a>
SN74LVC2G66DCTRE4	LIFEBUY	SM8	DCT	8	3000	RoHS & Green	NIPDAU	Level-1-260C-UNLIM	-40 to 85	C66 (R, Z)	
SN74LVC2G66DCTRG4	LIFEBUY	SM8	DCT	8	3000	RoHS & Green	NIPDAU	Level-1-260C-UNLIM	-40 to 85	C66 (R, Z)	
SN74LVC2G66DCUR	ACTIVE	VSSOP	DCU	8	3000	RoHS & Green	NIPDAU   SN	Level-1-260C-UNLIM	-40 to 85	(66, C66Q, C66R) CZ	<a href="#">Samples</a>
SN74LVC2G66DCURG4	ACTIVE	VSSOP	DCU	8	3000	RoHS & Green	NIPDAU	Level-1-260C-UNLIM	-40 to 85	C66R	<a href="#">Samples</a>
SN74LVC2G66DCUT	LIFEBUY	VSSOP	DCU	8	250	RoHS & Green	NIPDAU   SN	Level-1-260C-UNLIM	-40 to 85	(C66Q, C66R)	
SN74LVC2G66DCUTE4	ACTIVE	VSSOP	DCU	8	250	RoHS & Green	NIPDAU	Level-1-260C-UNLIM	-40 to 85	C66R	<a href="#">Samples</a>
SN74LVC2G66DCUTG4	ACTIVE	VSSOP	DCU	8	250	RoHS & Green	NIPDAU	Level-1-260C-UNLIM	-40 to 85	C66R	<a href="#">Samples</a>
SN74LVC2G66YZPR	ACTIVE	DSBGA	YZP	8	3000	RoHS & Green	SNAGCU	Level-1-260C-UNLIM	-40 to 85	(C67, C6N)	<a href="#">Samples</a>

(1) The marketing status values are defined as follows:

**ACTIVE:** Product device recommended for new designs.

**LIFEBUY:** TI has announced that the device will be discontinued, and a lifetime-buy period is in effect.

**NRND:** Not recommended for new designs. Device is in production to support existing customers, but TI does not recommend using this part in a new design.

**PREVIEW:** Device has been announced but is not in production. Samples may or may not be available.

**OBSELETE:** TI has discontinued the production of the device.

(2) **RoHS:** TI defines "RoHS" to mean semiconductor products that are compliant with the current EU RoHS requirements for all 10 RoHS substances, including the requirement that RoHS substance do not exceed 0.1% by weight in homogeneous materials. Where designed to be soldered at high temperatures, "RoHS" products are suitable for use in specified lead-free processes. TI may reference these types of products as "Pb-Free".

**RoHS Exempt:** TI defines "RoHS Exempt" to mean products that contain lead but are compliant with EU RoHS pursuant to a specific EU RoHS exemption.

**Green:** TI defines "Green" to mean the content of Chlorine (Cl) and Bromine (Br) based flame retardants meet JS709B low halogen requirements of <=1000ppm threshold. Antimony trioxide based flame retardants must also meet the <=1000ppm threshold requirement.

(3) MSL, Peak Temp. - The Moisture Sensitivity Level rating according to the JEDEC industry standard classifications, and peak solder temperature.

(4) There may be additional marking, which relates to the logo, the lot trace code information, or the environmental category on the device.

(5) Multiple Device Markings will be inside parentheses. Only one Device Marking contained in parentheses and separated by a "~" will appear on a device. If a line is indented then it is a continuation of the previous line and the two combined represent the entire Device Marking for that device.

(6) Lead finish/Ball material - Orderable Devices may have multiple material finish options. Finish options are separated by a vertical ruled line. Lead finish/Ball material values may wrap to two lines if the finish value exceeds the maximum column width.

**Important Information and Disclaimer:**The information provided on this page represents TI's knowledge and belief as of the date that it is provided. TI bases its knowledge and belief on information provided by third parties, and makes no representation or warranty as to the accuracy of such information. Efforts are underway to better integrate information from third parties. TI has taken and continues to take reasonable steps to provide representative and accurate information but may not have conducted destructive testing or chemical analysis on incoming materials and chemicals. TI and TI suppliers consider certain information to be proprietary, and thus CAS numbers and other limited information may not be available for release.

In no event shall TI's liability arising out of such information exceed the total purchase price of the TI part(s) at issue in this document sold by TI to Customer on an annual basis.

**OTHER QUALIFIED VERSIONS OF SN74LVC2G66 :**

- Automotive : [SN74LVC2G66-Q1](#)

NOTE: Qualified Version Definitions:

- Automotive - Q100 devices qualified for high-reliability automotive applications targeting zero defects

## TAPE AND REEL INFORMATION



### QUADRANT ASSIGNMENTS FOR PIN 1 ORIENTATION IN TAPE



\*All dimensions are nominal

Device	Package Type	Package Drawing	Pins	SPQ	Reel Diameter (mm)	Reel Width W1 (mm)	A0 (mm)	B0 (mm)	K0 (mm)	P1 (mm)	W (mm)	Pin1 Quadrant
SN74LVC2G66DCTR	SM8	DCT	8	3000	177.8	12.4	3.45	4.4	1.45	4.0	12.0	Q3
SN74LVC2G66DCTR	SM8	DCT	8	3000	180.0	13.0	3.35	4.5	1.55	4.0	12.0	Q3
SN74LVC2G66DCUR	VSSOP	DCU	8	3000	178.0	9.0	2.25	3.35	1.05	4.0	8.0	Q3
SN74LVC2G66DCURG4	VSSOP	DCU	8	3000	180.0	8.4	2.25	3.35	1.05	4.0	8.0	Q3
SN74LVC2G66DCUT	VSSOP	DCU	8	250	178.0	9.0	2.25	3.35	1.05	4.0	8.0	Q3
SN74LVC2G66DCUTG4	VSSOP	DCU	8	250	180.0	8.4	2.25	3.35	1.05	4.0	8.0	Q3
SN74LVC2G66YZPR	DSBGA	YZP	8	3000	178.0	9.2	1.02	2.02	0.63	4.0	8.0	Q1

**TAPE AND REEL BOX DIMENSIONS**

\*All dimensions are nominal

Device	Package Type	Package Drawing	Pins	SPQ	Length (mm)	Width (mm)	Height (mm)
SN74LVC2G66DCTR	SM8	DCT	8	3000	183.0	183.0	20.0
SN74LVC2G66DCTR	SM8	DCT	8	3000	182.0	182.0	20.0
SN74LVC2G66DCUR	VSSOP	DCU	8	3000	180.0	180.0	18.0
SN74LVC2G66DCURG4	VSSOP	DCU	8	3000	202.0	201.0	28.0
SN74LVC2G66DCUT	VSSOP	DCU	8	250	180.0	180.0	18.0
SN74LVC2G66DCUTG4	VSSOP	DCU	8	250	202.0	201.0	28.0
SN74LVC2G66YZPR	DSBGA	YZP	8	3000	220.0	220.0	35.0

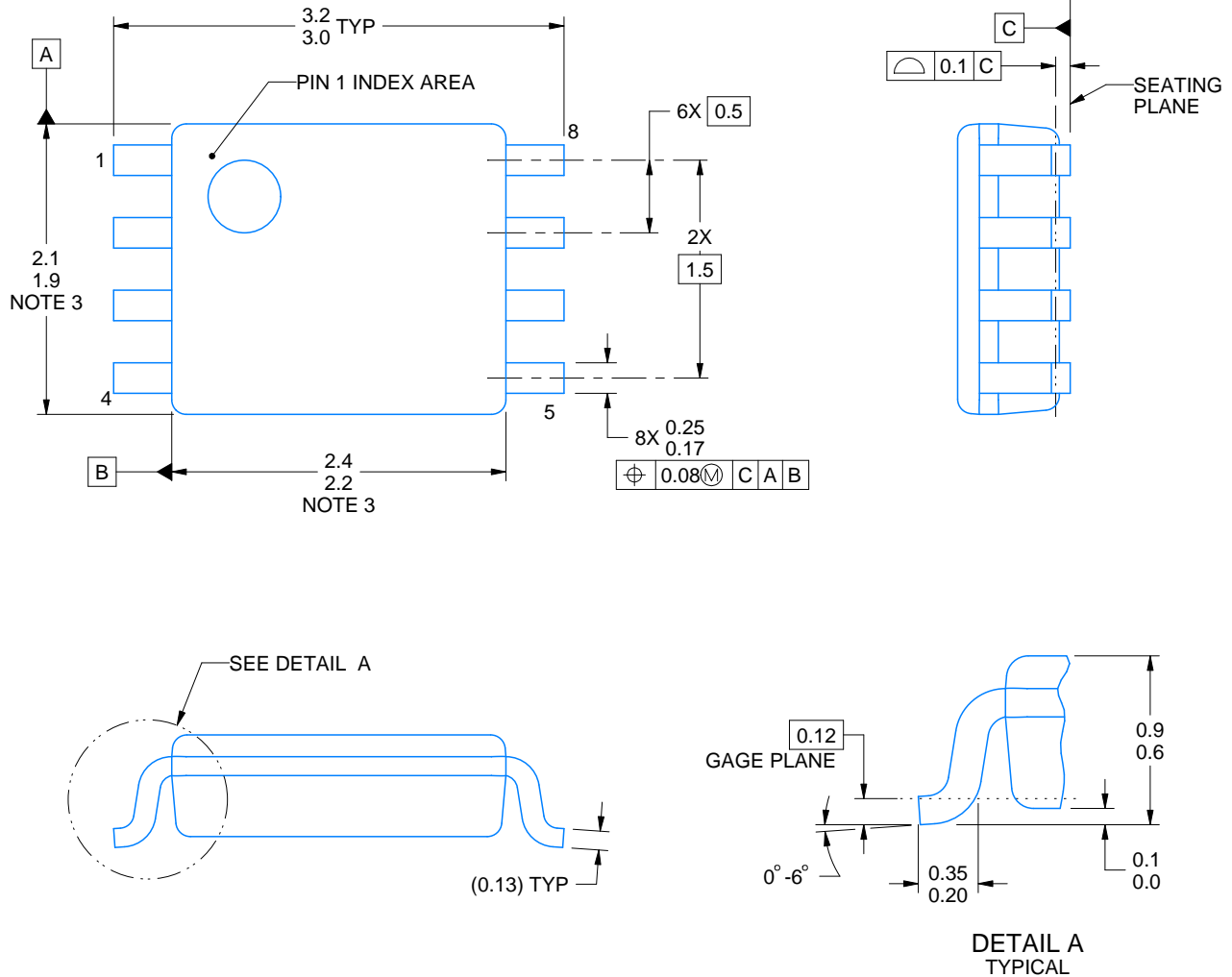

4225266/A 09/2014

NOTES:

1. All linear dimensions are in millimeters. Any dimensions in parenthesis are for reference only. Dimensioning and tolerancing per ASME Y14.5M.
2. This drawing is subject to change without notice.
3. This dimension does not include mold flash, protrusions, or gate burrs. Mold flash, protrusions, or gate burrs shall not exceed 0.15 mm per side.
4. Reference JEDEC registration MO-187 variation CA.

# EXAMPLE BOARD LAYOUT

DCU0008A

VSSOP - 0.9 mm max height

SMALL OUTLINE PACKAGE

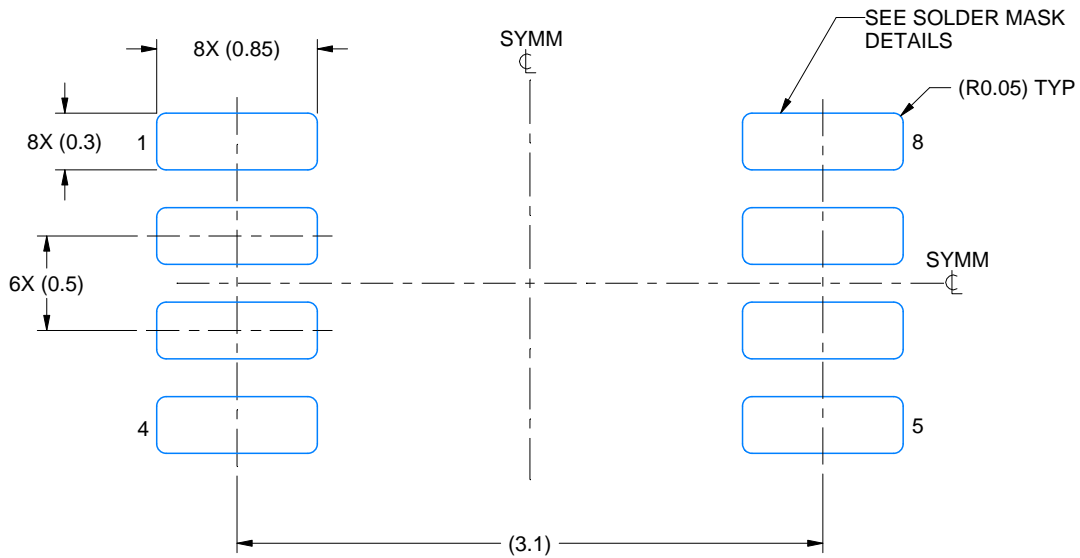

LAND PATTERN EXAMPLE  
EXPOSED METAL SHOWN  
SCALE: 25X

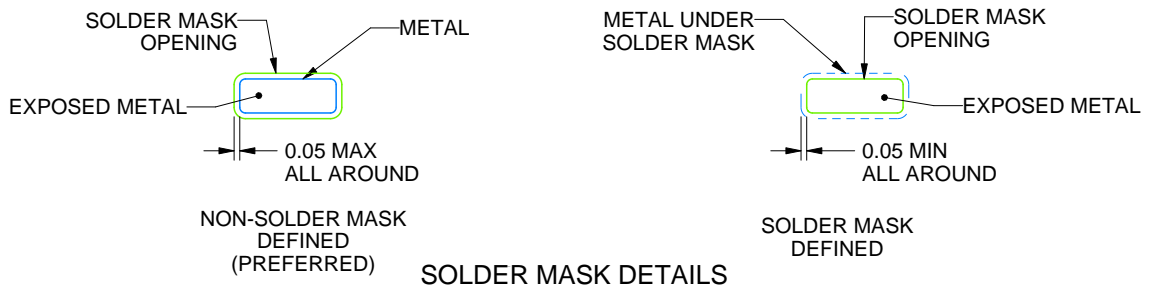

4225266/A 09/2014

NOTES: (continued)

5. Publication IPC-7351 may have alternate designs.
6. Solder mask tolerances between and around signal pads can vary based on board fabrication site.

# EXAMPLE STENCIL DESIGN

DCU0008A

VSSOP - 0.9 mm max height

SMALL OUTLINE PACKAGE

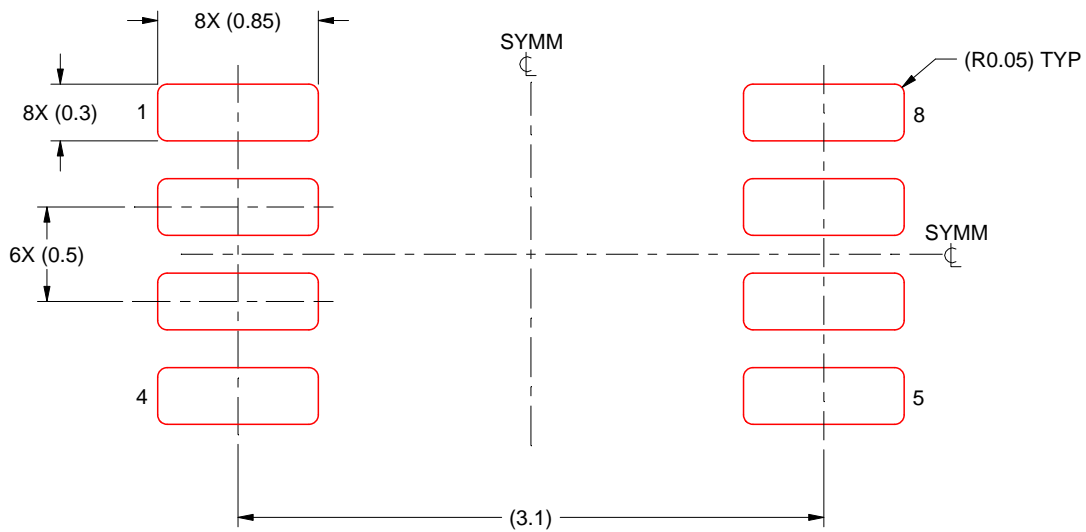

SOLDER PASTE EXAMPLE  
BASED ON 0.125 mm THICK STENCIL  
SCALE: 25X

4225266/A 09/2014

NOTES: (continued)

7. Laser cutting apertures with trapezoidal walls and rounded corners may offer better paste release. IPC-7525 may have alternate design recommendations.
8. Board assembly site may have different recommendations for stencil design.

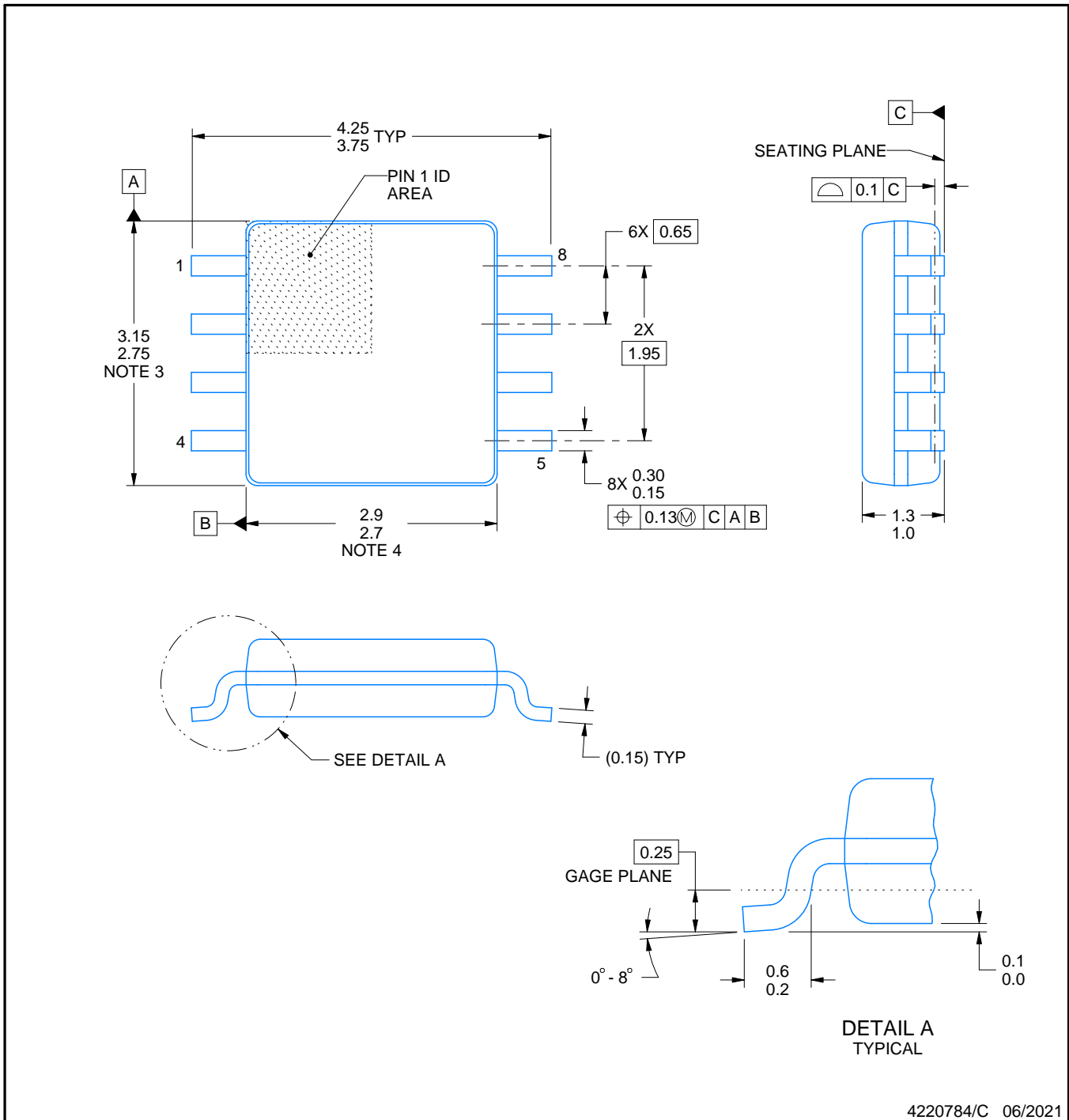
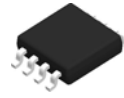

4220784/C 06/2021

NOTES:

1. All linear dimensions are in millimeters. Dimensions in parenthesis are for reference only. Dimensioning and tolerancing per ASME Y14.5M.
2. This drawing is subject to change without notice.
3. This dimension does not include mold flash, protrusions, or gate burrs. Mold flash, protrusions, or gate burrs shall not exceed 0.15 mm per side.
4. This dimension does not include interlead flash. Interlead flash shall not exceed 0.25 mm per side.

# EXAMPLE BOARD LAYOUT

DCT0008A

SSOP - 1.3 mm max height

SMALL OUTLINE PACKAGE

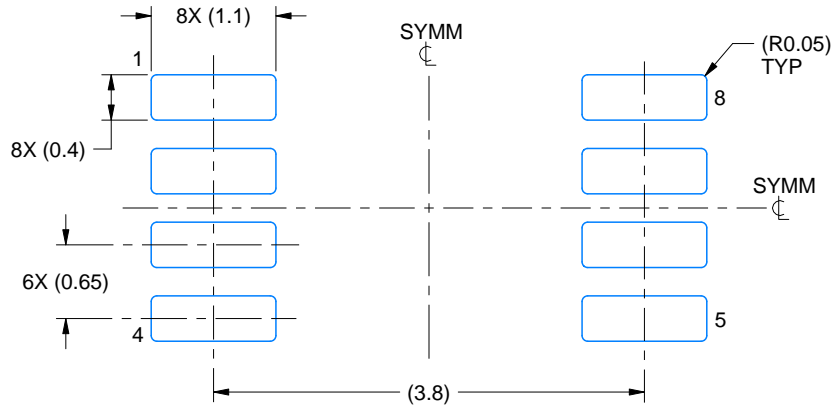

LAND PATTERN EXAMPLE  
EXPOSED METAL SHOWN  
SCALE:15X

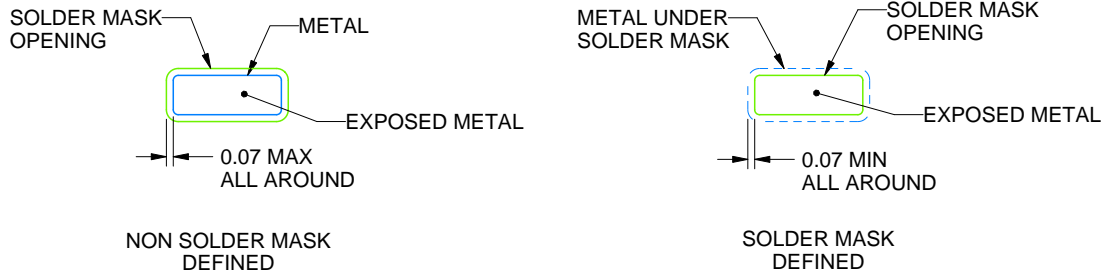

SOLDER MASK DETAILS

4220784/C 06/2021

NOTES: (continued)

5. Publication IPC-7351 may have alternate designs.
6. Solder mask tolerances between and around signal pads can vary based on board fabrication site.

# EXAMPLE STENCIL DESIGN

DCT0008A

SSOP - 1.3 mm max height

SMALL OUTLINE PACKAGE

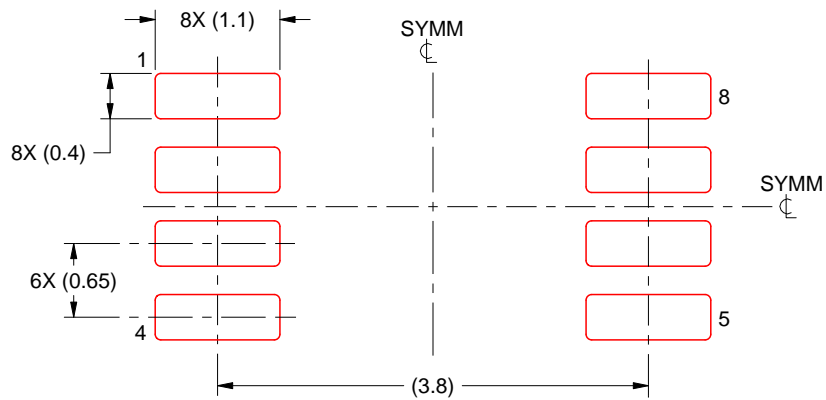

SOLDER PASTE EXAMPLE  
BASED ON 0.125 mm THICK STENCIL  
SCALE:15X

4220784/C 06/2021

NOTES: (continued)

7. Laser cutting apertures with trapezoidal walls and rounded corners may offer better paste release. IPC-7525 may have alternate design recommendations.
8. Board assembly site may have different recommendations for stencil design.



# EXAMPLE BOARD LAYOUT

YZP0008

DSBGA - 0.5 mm max height

DIE SIZE BALL GRID ARRAY

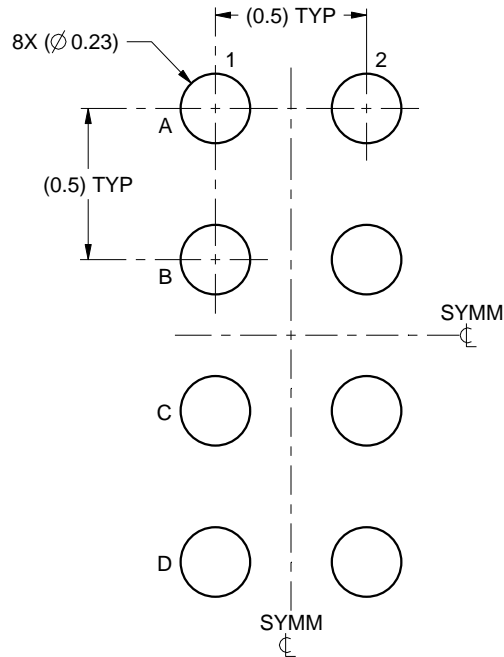

LAND PATTERN EXAMPLE  
SCALE:40X

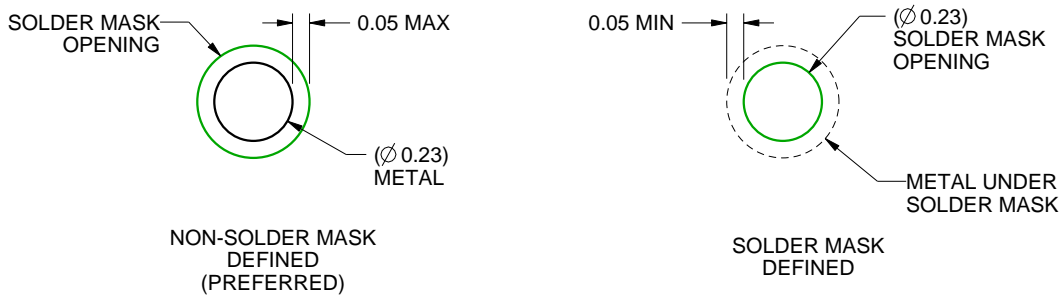

SOLDER MASK DETAILS  
NOT TO SCALE

4223082/A 07/2016

NOTES: (continued)

- Final dimensions may vary due to manufacturing tolerance considerations and also routing constraints. For more information, see Texas Instruments literature number SNVA009 ([www.ti.com/lit/snva009](http://www.ti.com/lit/snva009)).

# EXAMPLE STENCIL DESIGN

YZP0008

DSBGA - 0.5 mm max height

DIE SIZE BALL GRID ARRAY



SOLDER PASTE EXAMPLE  
BASED ON 0.1 mm THICK STENCIL  
SCALE:40X

4223082/A 07/2016

NOTES: (continued)

4. Laser cutting apertures with trapezoidal walls and rounded corners may offer better paste release.

## IMPORTANT NOTICE AND DISCLAIMER

TI PROVIDES TECHNICAL AND RELIABILITY DATA (INCLUDING DATA SHEETS), DESIGN RESOURCES (INCLUDING REFERENCE DESIGNS), APPLICATION OR OTHER DESIGN ADVICE, WEB TOOLS, SAFETY INFORMATION, AND OTHER RESOURCES "AS IS" AND WITH ALL FAULTS, AND DISCLAIMS ALL WARRANTIES, EXPRESS AND IMPLIED, INCLUDING WITHOUT LIMITATION ANY IMPLIED WARRANTIES OF MERCHANTABILITY, FITNESS FOR A PARTICULAR PURPOSE OR NON-INFRINGEMENT OF THIRD PARTY INTELLECTUAL PROPERTY RIGHTS.

These resources are intended for skilled developers designing with TI products. You are solely responsible for (1) selecting the appropriate TI products for your application, (2) designing, validating and testing your application, and (3) ensuring your application meets applicable standards, and any other safety, security, regulatory or other requirements.

These resources are subject to change without notice. TI grants you permission to use these resources only for development of an application that uses the TI products described in the resource. Other reproduction and display of these resources is prohibited. No license is granted to any other TI intellectual property right or to any third party intellectual property right. TI disclaims responsibility for, and you will fully indemnify TI and its representatives against, any claims, damages, costs, losses, and liabilities arising out of your use of these resources.

TI's products are provided subject to [TI's Terms of Sale](#) or other applicable terms available either on [ti.com](https://www.ti.com) or provided in conjunction with such TI products. TI's provision of these resources does not expand or otherwise alter TI's applicable warranties or warranty disclaimers for TI products.

TI objects to and rejects any additional or different terms you may have proposed.

Mailing Address: Texas Instruments, Post Office Box 655303, Dallas, Texas 75265  
Copyright © 2024, Texas Instruments Incorporated

## Looking for pricing, stock, or lifecycle information?

Click below to explore more details on WIN SOURCE:

 [View PS219B2-AS on WIN SOURCE](#)

 [Powerex Inc. Information](#)

## Optimize Your Supply Chain with WIN SOURCE Solutions

-  Global Sourcing Solution
-  Obsolete Management
-  Cost Control Management
-  Shortage Management
-  Alternative Solution
-  Excess Inventory Management