



**THE DATASHEET OF  
ALM-1412-TR1G**



## Data Sheet

### Description

Avago Technologies' ALM-1412 is an LNA module, with integrated filter, designed for GPS band applications at 1.575GHz. The LNA uses Avago Technologies' proprietary GaAs Enhancement-mode pHEMT process to achieve high gain with very low noise figure and high linearity. Noise figure distribution is very tightly controlled. A CMOS-compatible shutdown pin is included either for turning the LNA on/off, or for current adjustment. The integrated filter utilizes an Avago Technologies' leading-edge FBAR filter for exceptional rejection at Cell/PCS-Band frequencies.

The ALM-1412 is useable down to 1 V operation. It achieves low noise figure, high gain and linearity even at 1 V, making it suitable for use in critical low-power GPS applications or during low-battery situations.

### Application

- GPS Band LNA

### Component Image

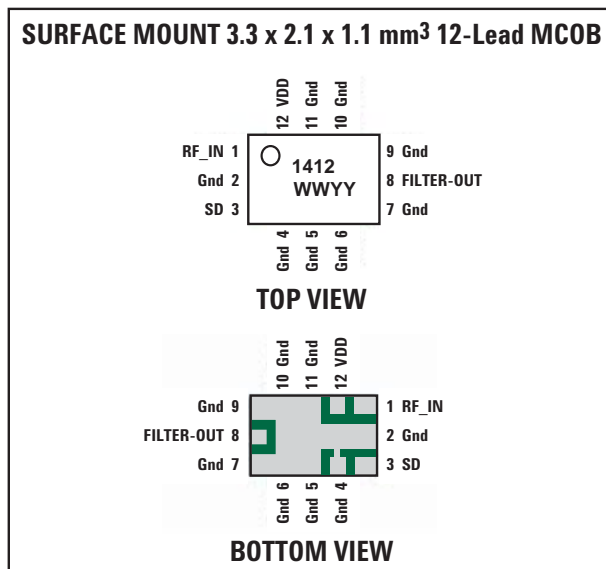

#### Note:

Package marking provides orientation and identification  
 "1412" = Product Code  
 "YY" = Year of manufacture  
 "WW" = Work Week of manufacture

### Features

- Very Low Noise Figure: 0.82 dB typical
- High Gain: 13.5 dB typical
- High IIP3 and IP1dB
- Exceptional Cell/PCS-Band rejection
- Advanced GaAs E-pHEMT Technology
- Low external component count
- Wide Supply Voltage: 1 V to 3.6 V
- Shutdown current: < 0.1  $\mu$ A
- CMOS compatible shutdown pin (SD) current @ 2.8 V: 0.1 mA
- Adjustable current via single external resistor/voltage
- Meets MSL3 and Lead-Free
- ESD-protected RF input: 3 kV HBM
- Small package dimension: 3.3(L)x2.1(W)x1.1(H) mm<sup>3</sup>

### Specifications (Typical Performance at 25°C)

At 1.575 GHz, Vdd = 2.85 V, Idd = 8.0 mA

- Gain = 13.5 dB
- NF = 0.82 dB
- IIP3 = +7.0 dBm, IP1dB = +2.7 dBm
- S11 = -8.4 dB, S22 = -12.3 dB
- Cell-Band Rejection: 54 dBc
- PCS-Band Rejection: 63 dBc

At 1.575 GHz, 1.0 V supply

- S21 = 8.8 dB
- NF = 1.22 dB
- Idd = 1.9 mA



#### Attention: Observe precautions for handling electrostatic sensitive devices.

For RF\_IN (Pin 1): ESD Human Body Model = 3 kV  
 All other pins: ESD Machine Model = 40 V  
 ESD Human Body Model = 300 V

Refer to Avago Technologies Application Note A004R:  
 Electrostatic Discharge, Damage and Control

**Absolute Maximum Rating<sup>[1]</sup> T<sub>A</sub> = 25°C**

Symbol	Parameter	Units	Absolute Max.
V <sub>dd</sub>	Device Drain to Source Voltage <sup>[2]</sup>	V	3.6
I <sub>dd</sub>	Drain Current <sup>[2]</sup>	mA	20
P <sub>in,max</sub>	CW RF Input Power (V <sub>dd</sub> = 2.85 V, I <sub>dd</sub> = 9.0 mA)	dBm	15
P <sub>diss</sub>	Total Power Dissipation <sup>[4]</sup>	mW	72
T <sub>j</sub>	Junction Temperature	°C	150
T <sub>STG</sub>	Storage Temperature	°C	-65 to 150
T	Recommended Operating Temperature	°C	-40 to 85

**Thermal Resistance<sup>[3]</sup>** (V<sub>dd</sub> = 2.85 V, I<sub>dd</sub> = 9 mA), θ<sub>jc</sub> = 352.2°C/W

**Notes:**

1. Operation of this device in excess of any of these limits may cause permanent damage.
2. Assuming DC quiescent conditions.
3. Thermal resistance measured using Infra-Red measurement technique.
4. Board (module belly) temperature T<sub>B</sub> is 25°C. Derate 2.84 mW/°C for T<sub>B</sub> > 125°C.

**Electrical Specifications**

T<sub>A</sub> = 25°C, V<sub>dd</sub> = +2.85V, V<sub>sd</sub> = +2.6V, I<sub>dd</sub> = 8mA (typ), R<sub>2</sub> = 10 kΩ, Freq = 1.575GHz - Typical Performance <sup>[8]</sup> unless otherwise specified.

**Table 1. Performance Table at Nominal Operating Conditions**

Symbol	Parameter and Test Condition	Units	Min.	Typ	Max.
G	Gain	dB	11	13.5	-
NF <sup>[7]</sup>	Noise Figure	dB	-	0.82	1.2
IP1dB	Input 1 dB Compressed Power	dBm	-	2.7	-
IIP3 <sup>[9]</sup>	Input 3rd Order Intercept Point (2-tone @ f <sub>c</sub> ± 2.5 MHz)	dBm	-	7.0	-
S11	Input Return Loss	dB	-	-8.4	-
S22	Output Return Loss	dB	-	-12.3	-
S12	Reverse Isolation	dB	-	-23	-
Cell Band Rejection	Relative to 1.575 GHz @ 827.5 MHz	dBc	45	54	-
PCS Band Rejection	Relative to 1.575 GHz @ 1885 MHz	dBc	45	63	-
I <sub>dd</sub>	Supply DC current at Shutdown (SD) Voltage V <sub>sd</sub> = 2.6 V	mA	-	8.0	15
I <sub>sh</sub>	Shutdown Current @ V <sub>sd</sub> = 0 V	µA	-	0.1	-

T<sub>A</sub> = 25°C, V<sub>dd</sub> = +2.85V, V<sub>sd</sub> = +1.8V, I<sub>dd</sub> = 4.5mA (typ), R<sub>2</sub> = 10 kΩ, Freq = 1.575GHz - Typical Performance<sup>[8]</sup> unless otherwise specified.

**Table 2. Typical Performance at V<sub>dd</sub> = +2.85V, V<sub>sd</sub> = +1.8V, I<sub>dd</sub> = 4.5mA (typ)**

Symbol	Parameter and Test Condition	Units	Typ.
G	Gain	dB	12.2
NF <sup>[7]</sup>	Noise Figure	dB	0.94
IP1dB	Input 1 dB Compressed Power	dBm	4.5
IIP3 <sup>[9]</sup>	Input 3rd Order Intercept Point (2-tone @ f <sub>c</sub> ± 2.5 MHz)	dBm	5.7
S11	Input Return Loss	dB	-7
S22	Output Return Loss	dB	-10.6
S12	Reverse Isolation	dB	-22.6
Cell Band Rejection	Relative to 1.575 GHz @ 827.5 MHz	dBc	55
PCS Band Rejection	Relative to 1.575 GHz @ 1885 MHz	dBc	61
I <sub>dd</sub>	Supply DC Current at Shutdown (SD) Voltage V <sub>sd</sub> = 1.8 V	mA	4.5
I <sub>sh</sub>	Shutdown Current @ V <sub>sd</sub> = 0 V	µA	0.1

**Notes:**

7. For noise figure measurement, input board loss has not been deducted.
8. Measurements at 1.575 GHz obtained using demo board described in Figures 6 and 7.
9. 1.575 GHz IIP3 test condition: F<sub>RF1</sub> = 1572.5 MHz, F<sub>RF2</sub> = 1577.5 MHz with input power of -20 dBm per tone measured at the worst case side band.

Vdd = +2 V, Vdd = +1.5 V, Vdd = +1 V, Freq = 1.575 GHz – Typical Performance<sup>[8]</sup> (Vsd = Vdd, R2 = 0 ohms)

**Table 3. Typical Performance at Low Operating Voltages with R2 (See Figures 6 and 7) Set to 0 ohms**

Symbol	Parameter and Test Condition	Units	Vdd = 2 V	Vdd = 1.5 V	Vdd = 1 V
G	Gain	dB	13.3	12.2	8.8
NF <sup>[7]</sup>	Noise Figure	dB	0.79	0.88	1.22
IP1dB	Input 1 dB Compressed Power	dBm	-0.8	-1.5	-1.6
IIP3 <sup>[9]</sup>	Input 3rd Order Intercept Point (2-tone @ fc ± 2.5 MHz)	dBm	8.4	6.3	4.8
S11	Input Return Loss	dB	-8.8	-7.4	-4.8
S22	Output Return Loss	dB	-12.4	-10.7	-7.8
S12	Reverse Isolation	dB	-21.3	-20.2	-17.7
Cell Band Rejection	Relative to 1.575 GHz @ 827.5 MHz	dBc	52.4	54.3	54.8
PCS Band Rejection	Relative to 1.575 GHz @ 1885 MHz	dBc	65.4	64.5	64.2
Idd	Supply DC Current	mA	9.8	5.6	1.9
Ish	Shutdown Current @ Vsd = 0 V	μA	0.1	0.1	0.1

**Notes:**

7. For noise figure measurement, input board loss has not been deducted.
8. Measurements at 1.575 GHz obtained using demo board described in Figures 6 and 7.
9. 1.575 GHz IIP3 test condition: F<sub>RF1</sub> = 1572.5 MHz, F<sub>RF2</sub> = 1577.5 MHz with input power of -20 dBm per tone measured at the worst case side band.

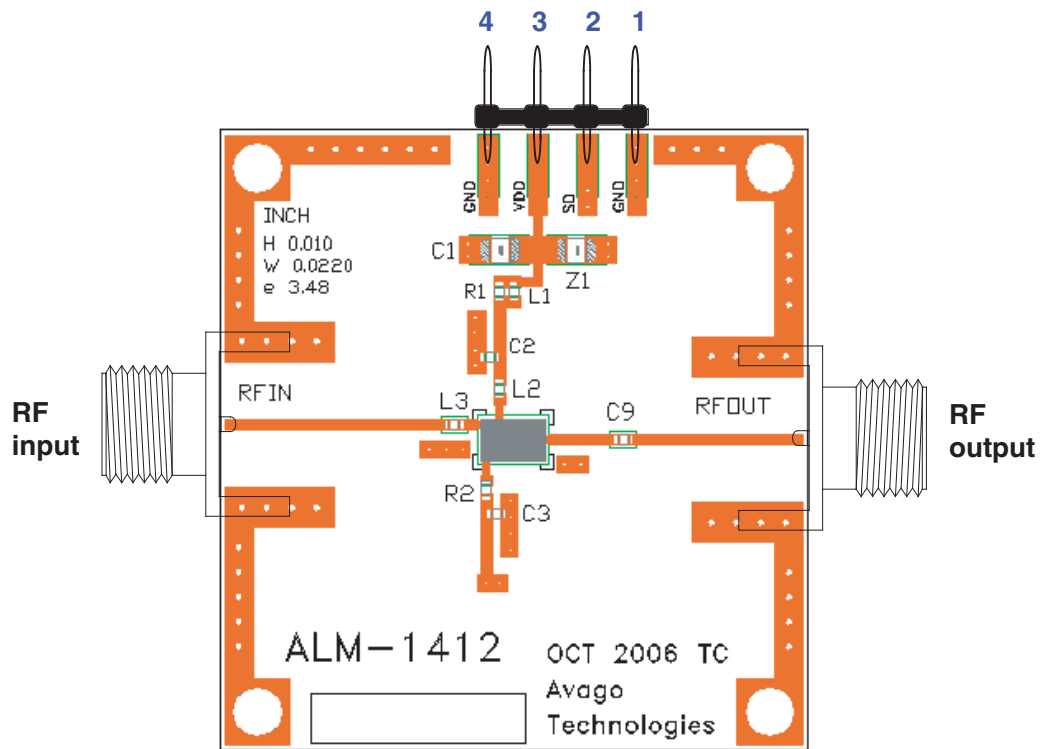

**DC Pin Configuration of 4-pin Connector**

Pins pointing  
out of the page

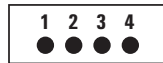

Pins 1, 4 - GND  
Pin 2 = Shutdown (SD)  
Pin 3 = Vdd Supply

Circuit Symbol	Size	Description
L1	0402	Not Used
L2	0402	6.8 nH Inductor (Toko)
L3	0402	5.6 nH Inductor (Toko)
C1	0805	0.1 $\mu$ F Capacitor (Murata)
C2	0402	10 pF Capacitor (Rohm)
C3	0402	6.8 pF Capacitor (Rohm)
C9	0402	100 pF Capacitor (Rohm)
R1	0402	12 Ohms Resistor (Rohm)
R2	0402	10k Ohms Resistor (Rohm)
Z1	0805	Not Used

Figure 1. Demoboard and application circuit components table

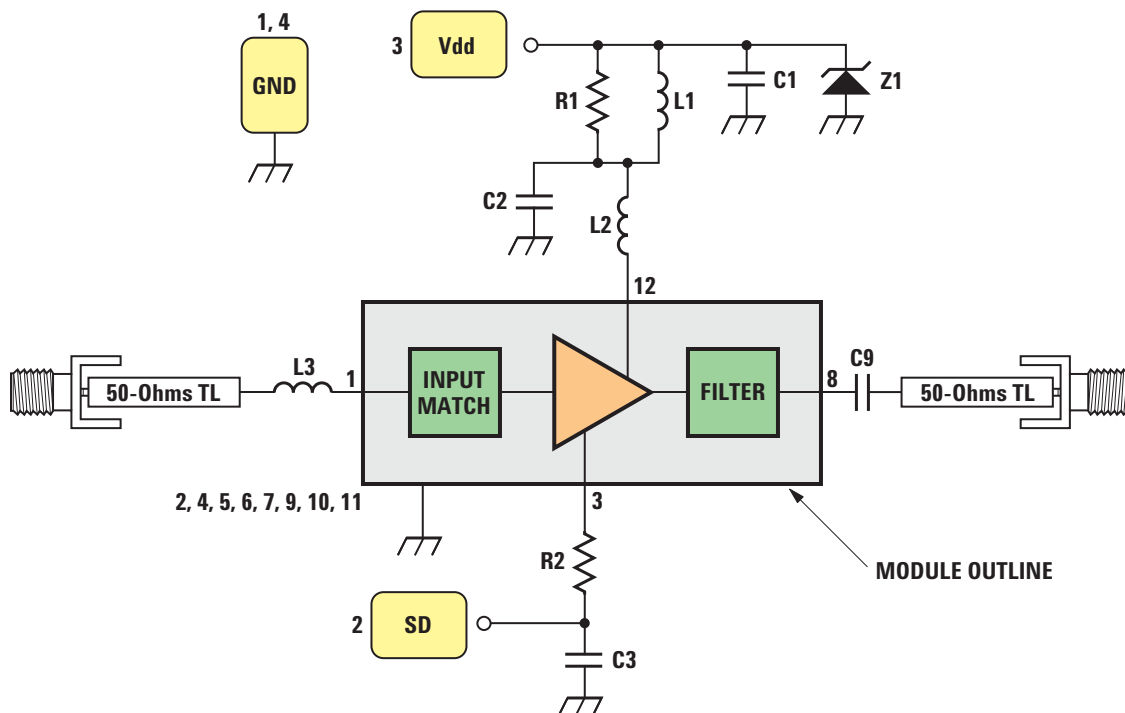

**Figure 2. Demoboard and application schematic diagram**

**Notes:**

- The demoboard of Figure 6 is Rogers® RO4350 with typical Dk=3.48 (@10GHz).
- L3 and the module's internal input pre-match form the input matching network. The RFin pin, pin 1, is directly connected to a shunt inductor that is grounded. The RF output filter blocks DC.
- This circuit demonstrates that very low noise figure is obtainable with standard 0402 chip inductors instead of high-Q wirewound inductors.
- C2 and L2 form a matching network at the output of the LNA stage, which can be tuned to optimize gain and return loss. For example, higher gain can be obtained by increasing the value of C2 but at the expense of stability. Changing the value of L2 can improve the PCS rejection, but impacts output return loss.
- L1 is a choke which isolates the demoboard from external disturbances during measurement. It is not needed in actual application. Likewise, C1 and C3 mitigate the effect of external noise pickup on the Vdd and SD lines respectively. These components are not required in actual operation.
- R1 is a stability-enhancing resistor.
- C9 is a DC-blocking capacitor. It is also not required in actual operation.
- Bias control is achieved by either varying the SD voltage (Vsd) with/without R2, or fixing the SD voltage to Vdd and adjusting R2 for the desired current. Typical value for R2 is 10k Ohms for 8 mA total current at Vdd = 2.85 V and Vsd = +2.60 V. For applications where it is more appropriate to have SD (Vsd) connected to Vdd, a 12 k Ohms resistor value for R2 is suggested (where Vdd = 2.85 V).
- For low-voltage operation such as Vdd = 1.5 V or 1.0 V, R2 may be omitted and SD (Vsd) connected directly to Vdd.
- The grounding regime for the ALM-1412 is critical to achieving the PCS- and Cell-Band Rejections shown in Figure 9. Please refer to the PCB Land Patterns section of this document for the exact locations of the grounding vias.

**ALM-1412 Typical Performance Curves, Vdd = +2.85 V, Vsd = +2.6V, Idd = 8mA (typ)  
(at 25°C unless specified otherwise)**

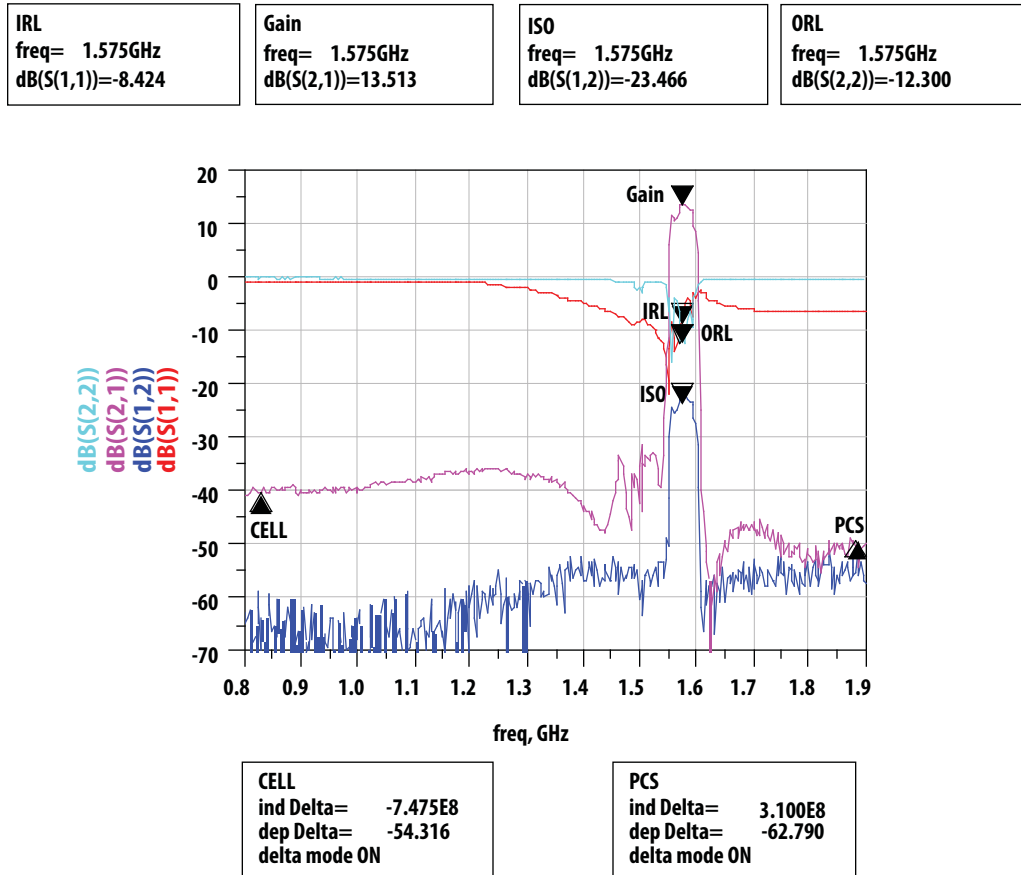

Figure 3. Typical S-Parameter plot

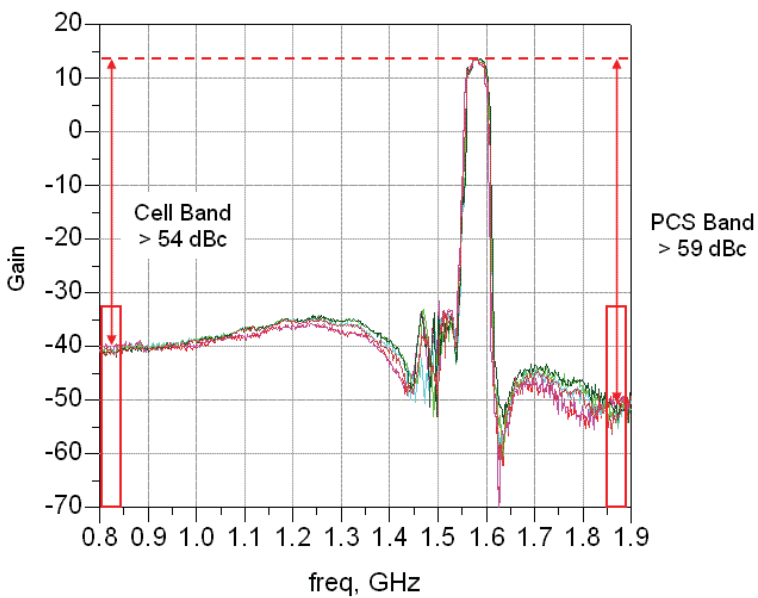

Figure 4. Multiple module plots of rejecton at Cell and PCS Bands

**ALM-1412 Typical Performance Curves, R2 = 10 kΩ**  
 (at 25°C unless specified otherwise)

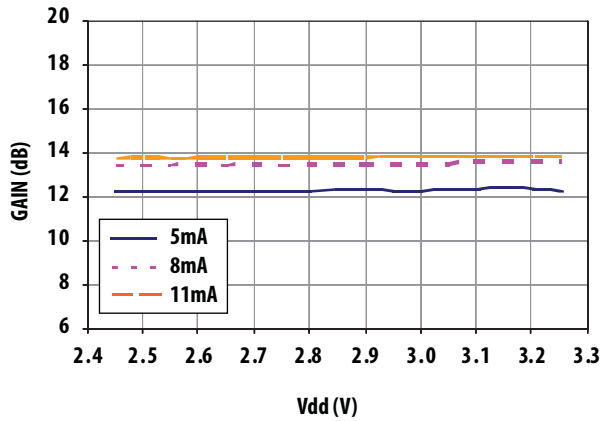

Figure 5. Gain vs. Vdd vs. Idd

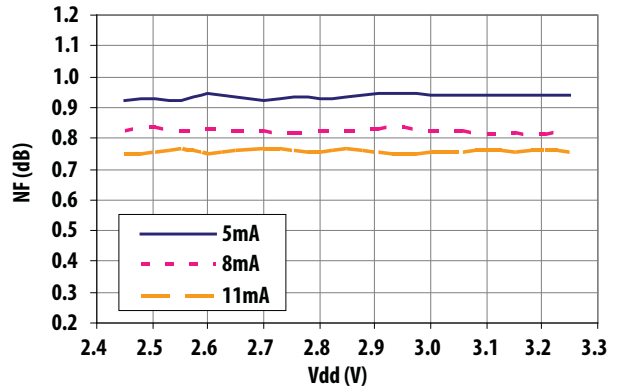

Figure 6. NF vs. Vdd vs. Idd

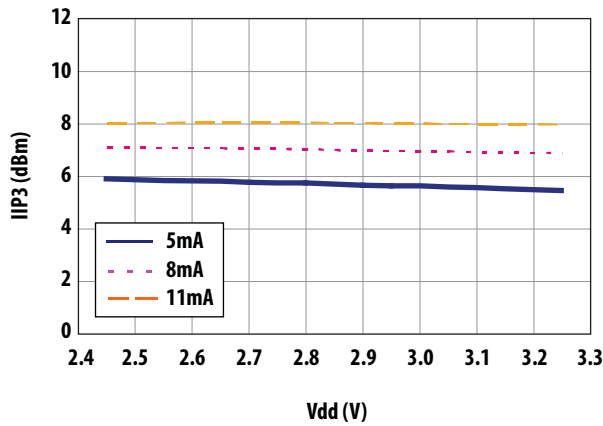

Figure 7. IIP3 vs. Vdd vs. Idd

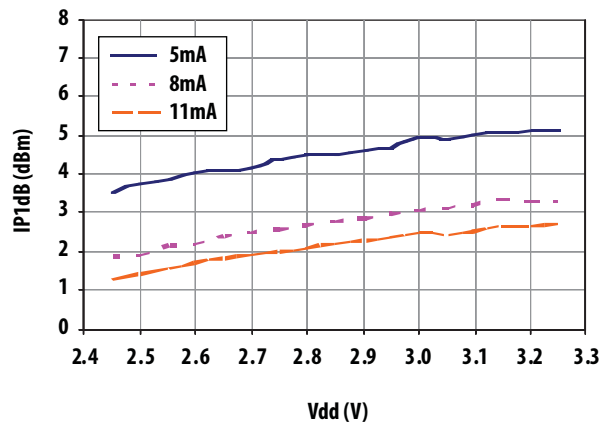

Figure 8. IP1dB vs. Vdd vs. Idd

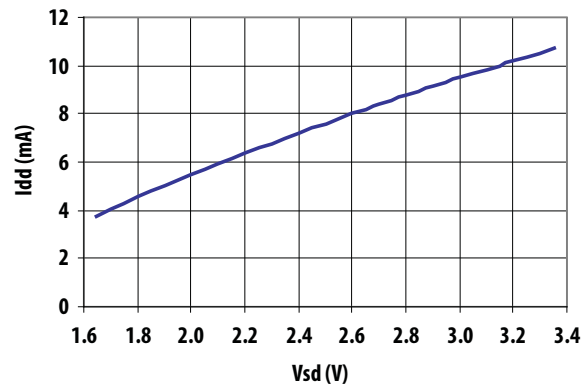

Figure 9. Idd vs. Vsd (Vdd = 2.85 V)

**ALM-1412 Typical Performance Curves, R2 = 10 kΩ  
(at 25°C unless specified otherwise)**

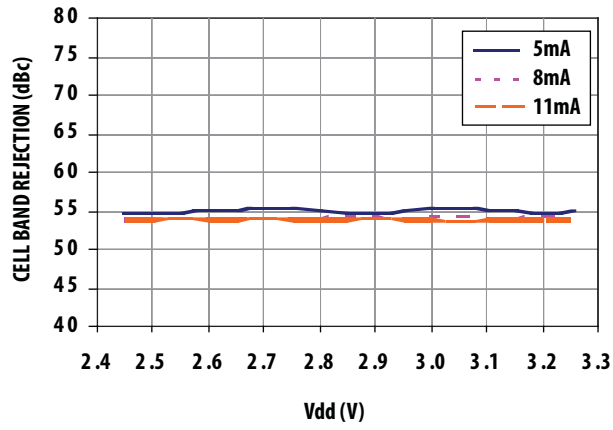

Figure 10. Cell band rejection vs. Vdd vs. Idd

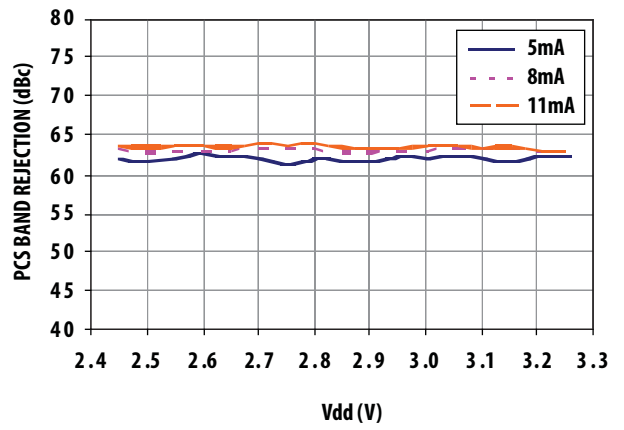

Figure 11. PCS band rejection vs. Vdd vs. Idd

**ALM-1412 Typical Performance Curves, R2 = 10 kΩ**  
 (at 25°C unless specified otherwise)

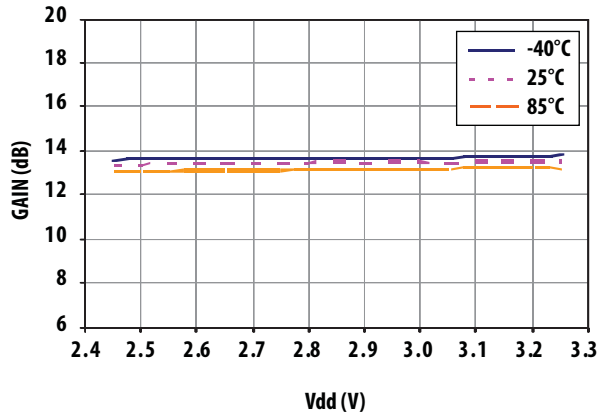

Figure 12. Gain vs. Vdd vs. Temp (Idd = 8 mA)

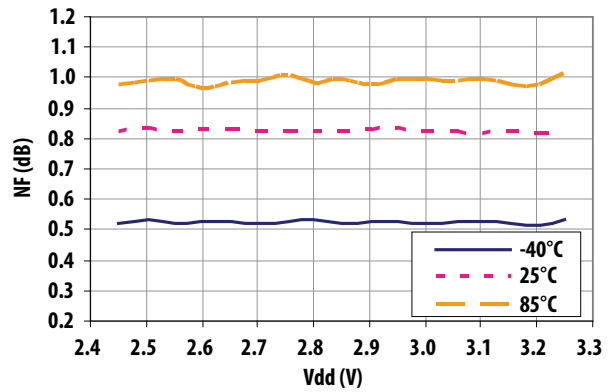

Figure 13. NF vs. Vdd vs. Temp (Idd = 8 mA)

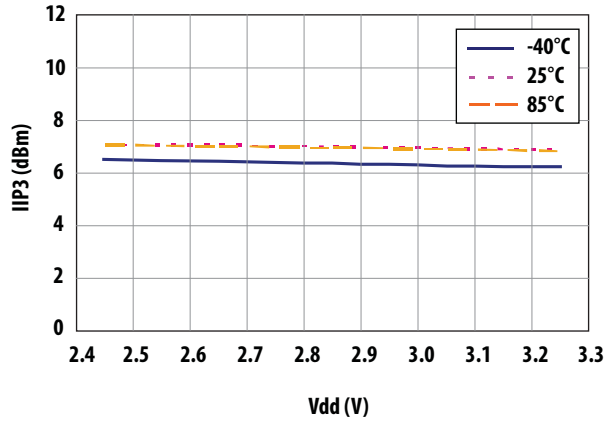

Figure 14. IIP3 vs. Vdd vs. Temp (Idd = 8 mA)

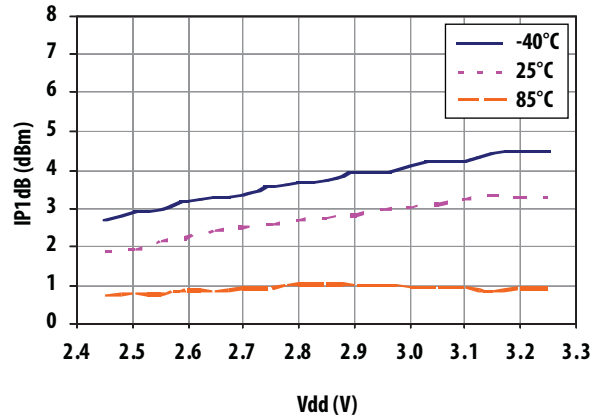

Figure 15. IP1dB vs. Vdd vs. Temp (Idd = 8 mA)

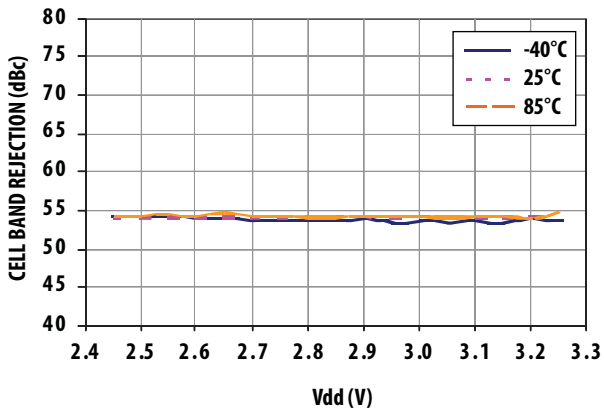

Figure 16. Cell band rejection vs. Vdd vs. Temp (Idd = 8 mA)

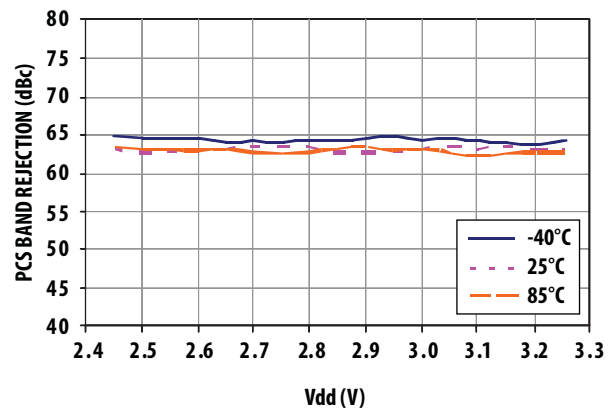

Figure 17. PCS band rejection vs. Vdd vs. Temp (Idd = 8 mA)

# ALM-1412 Scattering Parameter and Noise Parameter Measurement

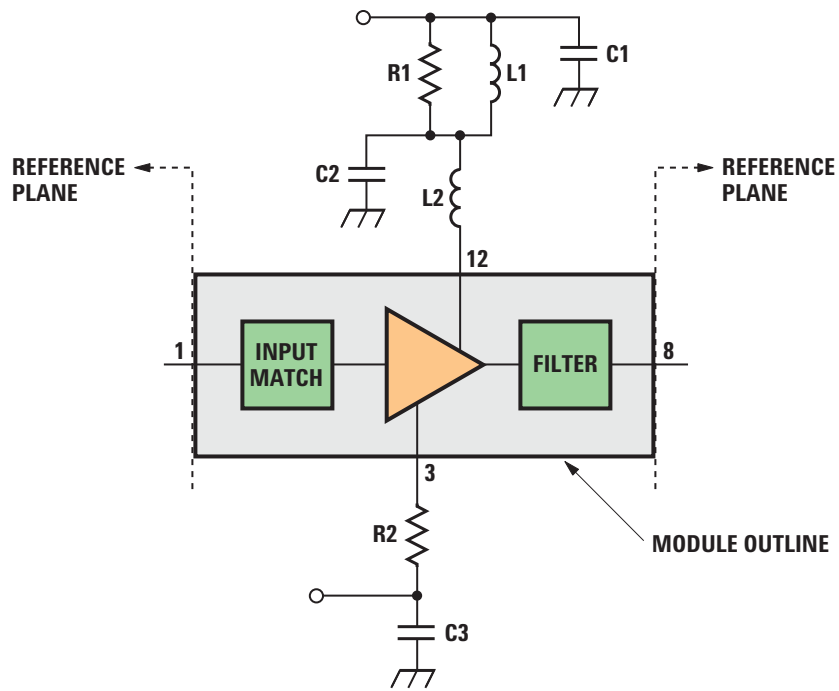

Figure 18. Scattering and noise parameter reference planes

### ALM-1412 Typical Scattering Parameters at 25°C, Vdd = 2.85 V, Vsd = +2.6V, Idd = 8mA (typ)

The S- and Noise Parameters are measured using the PCB described in Figures 6 and 7. The PCB material is 10 mils Rogers® RO4350. Figure 23 shows the input and output reference planes. The circuit values, with the exception of L3, are as indicated in Figure 6.

Freq.	S11	S11	S21	S21	S21	S12	S12	S22	S22
(GHz)	Mag.	Ang.	(dB)	Mag.	Ang.	(dB)	Ang.	Mag.	Ang.
0.3	0.9414	51.75	-49.77	0.0032	-82.50	-59.00	84.27	1.0023	-37.50
0.5	0.9810	14.17	-43.75	0.0065	-131.02	-60.91	54.30	1.0081	-62.37
0.7	0.9591	-10.49	-41.23	0.0087	178.63	-63.01	87.77	1.0077	-88.32
0.8	0.9388	-19.17	-42.09	0.0079	147.58	-64.55	123.93	1.0022	-100.80
0.8275	0.9413	-21.42	-40.90	0.0090	146.27	-62.48	-178.15	1.0000	-103.57
0.9	0.9349	-27.77	-41.36	0.0086	112.88	-56.91	-170.87	1.0069	-113.18
1.0	0.9441	-36.81	-40.49	0.0095	89.73	-74.17	-165.29	1.0017	-126.25
1.1	0.9572	-45.08	-38.82	0.0115	78.49	-67.03	-161.43	0.9907	-139.12
1.2	0.9507	-57.62	-39.07	0.0111	156.91	-59.29	-160.46	0.9923	-152.69
1.3	0.9015	-68.40	-39.84	0.0102	146.64	-60.70	-160.88	0.9829	-166.42
1.4	0.7906	-80.81	-45.10	0.0056	146.20	-55.58	168.45	0.9680	176.91
1.5	0.6713	-82.27	-34.14	0.0196	112.86	-54.66	155.19	0.7419	152.58
1.575	0.7112	-78.76	11.00	3.5490	-179.44	-24.28	141.36	0.2017	8.18
1.6	0.8218	-80.17	4.62	1.7030	16.26	-31.07	-119.97	0.5525	-118.95
1.7	0.6027	-96.78	-46.90	0.0045	-76.04	-59.93	165.69	0.9574	170.98
1.8	0.5047	-98.62	-51.12	0.0028	137.34	-54.87	152.40	0.9564	153.50
1.885	0.4471	-97.54	-48.14	0.0039	125.57	-51.80	147.55	0.9561	140.48
1.9	0.4373	-96.29	-46.03	0.0050	117.45	-53.03	145.64	0.9492	138.24
2.0	0.3906	-98.29	-42.75	0.0073	110.90	-53.46	146.79	0.9488	135.73
2.1	0.3534	-98.68	-39.84	0.0102	100.81	-54.69	145.47	0.9501	132.67
2.2	0.3250	-97.55	-37.92	0.0127	90.59	-52.67	145.94	0.9493	130.76
2.3	0.3017	-97.11	-36.71	0.0146	82.48	-50.18	140.43	0.9475	126.47
2.4	0.2839	-97.10	-35.73	0.0164	74.79	-51.46	138.69	0.9514	123.07
2.5	0.2674	-97.35	-35.47	0.0169	67.94	-48.85	136.17	0.9488	115.08
3.0	0.2097	-95.65	-44.33	0.0061	47.58	-46.49	71.43	0.9164	81.72
3.5	0.1691	-179.25	-19.72	0.1032	50.34	-46.47	42.11	0.8395	54.36
4.0	0.1230	-115.88	-6.17	0.4912	6.00	-28.93	-1.39	0.6672	4.25
4.5	0.1062	62.61	-2.49	0.7511	-31.75	-21.92	-38.31	0.6478	-111.97
5.0	0.2175	95.87	-1.53	0.8390	-75.46	-19.00	-79.92	0.6836	174.58

**ALM-1412 Typical Scattering Parameters at 25°C, Vdd = 2.85 V, Vsd = +1.8V, Idd = 4.5mA (typ)**

Freq.	S11	S11	S21	S21	S21	S12	S12	S22	S22
(GHz)	Mag.	Ang	(dB)	Mag.	Ang.	(dB)	Ang.	Mag.	Ang.
0.3	0.9364	50.71	-53.96	0.0020	-75.83	-61.10	117.42	1.0036	-67.48
0.5	0.9751	15.23	-46.49	0.0047	-108.30	-60.19	130.25	1.0091	-92.35
0.7	0.9673	-6.10	-43.23	0.0069	172.32	-60.93	153.21	1.0081	-118.06
0.8	0.9594	-17.41	-44.12	0.0062	158.60	-65.24	157.05	1.0065	-130.84
0.8275	0.9620	-18.73	-42.71	0.0073	151.74	-64.92	160.63	1.0044	-143.78
0.9	0.9561	-25.18	-43.36	0.0068	143.86	-68.55	167.31	1.0109	-153.10
1.0	0.9702	-33.12	-42.08	0.0079	131.02	-69.59	168.93	1.0014	-156.24
1.1	0.9853	-45.50	-40.02	0.0100	102.19	-63.56	-167.21	0.9951	-159.18
1.2	0.9832	-55.01	-39.99	0.0100	83.16	-60.26	-164.86	0.9880	-162.29
1.3	0.9174	-66.05	-40.58	0.0094	158.44	-57.20	-168.56	0.9810	-166.49
1.4	0.7806	-74.79	-46.41	0.0048	144.44	-58.60	172.11	0.9707	176.62
1.5	0.6815	-75.29	-35.60	0.0166	113.76	-55.03	148.58	0.7437	152.64
1.575	0.7590	-67.75	9.47	2.9746	-173.00	-23.78	95.42	0.2765	36.80
1.6	0.8472	-77.47	3.74	1.5389	25.43	-29.97	-153.49	0.5556	-77.55
1.7	0.5954	-90.66	-47.04	0.0044	-87.32	-65.08	167.45	0.9606	160.90
1.8	0.5238	-88.12	-51.13	0.0028	147.21	-54.74	163.04	0.9551	143.44
1.885	0.4902	-88.21	-48.17	0.0039	125.81	-53.26	161.83	0.9588	131.24
1.9	0.4849	-88.08	-48.81	0.0036	122.10	-52.38	159.39	0.9499	129.02
2.0	0.4619	-89.75	-44.66	0.0059	117.06	-55.18	158.23	0.9509	125.92
2.1	0.4440	-91.88	-41.53	0.0084	109.11	-57.03	157.00	0.9500	122.66
2.2	0.4287	-92.90	-39.49	0.0106	103.36	-50.38	156.56	0.9506	119.90
2.3	0.4139	-93.21	-38.54	0.0118	100.64	-50.53	155.91	0.9502	116.38
2.4	0.4020	-93.65	-37.61	0.0132	95.20	-51.69	144.89	0.9528	113.17
2.5	0.3893	-94.26	-37.18	0.0138	84.68	-50.37	143.27	0.9480	110.07
3.0	0.3157	-97.95	-45.77	0.0051	50.49	-45.39	93.11	0.9165	88.75
3.5	0.2328	-128.95	-21.05	0.0886	35.94	-47.72	37.99	0.8401	44.39
4.0	0.1727	-150.95	-7.39	0.4273	8.77	-29.65	-8.04	0.6713	-4.21
4.5	0.1912	150.04	-3.65	0.6570	-32.72	-22.55	-51.38	0.6572	-72.14
5.0	0.2939	93.40	-2.66	0.7363	-64.48	-19.74	-85.59	0.6929	174.27

**ALM-1412 Typical Noise Parameters at 25°C,  
Freq = 1.575 GHz, Vdd = 2.85 V, Vsd = +2.6V, Idd = 8mA (typ)**

Freq (GHz)	Fmin (dB)	GAMMA OPT		
		Mag	Ang	Rn/50
1.575	0.7	0.55	62	0.36

**ALM-1412 Typical Noise Parameters at 25°C,  
Freq = 1.575 GHz, Vdd = 2.85 V, Vsd = +1.8V, Idd = 4.5mA (typ)**

Freq (GHz)	Fmin (dB)	GAMMA OPT		
		Mag	Ang	Rn/50
1.575	0.85	0.54	71	0.36

Notes:

- The exceptional noise figure performance of the ALM-1412 is due to its highly optimized design. In this regard, the Fmin of the ALM-1412 shown above is locked down by the internal input pre-match. This allows the use of relatively inexpensive chip inductors for external matching.
- The NF performance of the ALM-1412 is also very resilient to operating conditions. For example, at Idd = 4.5 mA, the degradation in NF is only 0.1 dB, and not more than 0.15 dB degradation over temperature.

**Part Number Ordering Information**

Part Number	No. of Devices	Container
ALM-1412-BLKG	100	Antistatic bag
ALM-1412 -TR1G	3000	13" Reel

## Package Dimensions

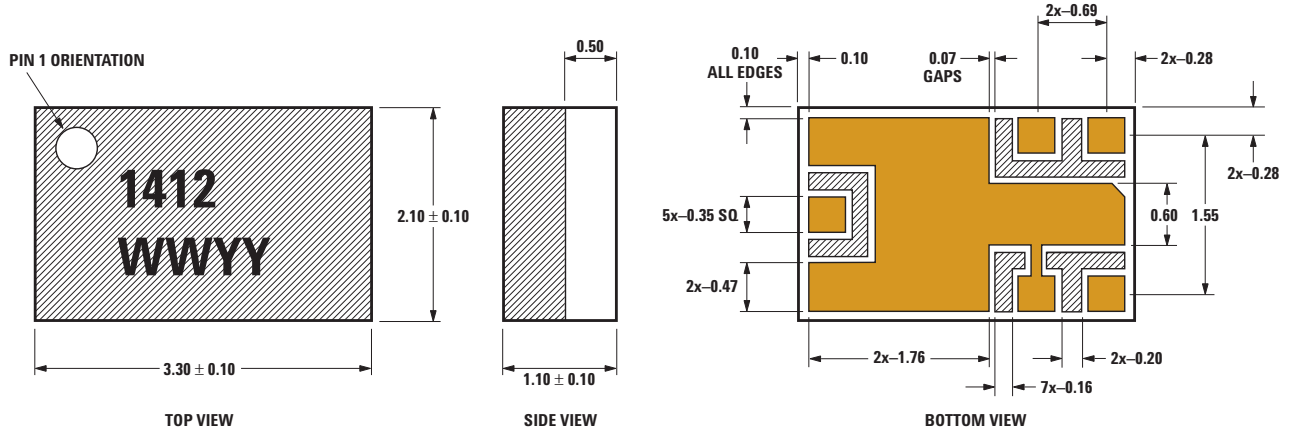

### NOTES:

1. ALL DIMENSIONS ARE IN MILLIMETERS.
2. DIMENSIONS ARE INCLUSIVE OF PLATING.
3. DIMENSIONS ARE EXCLUSIVE OF MOLD FLASH AND METAL BURR.

## PCB Land Patterns and Stencil Design

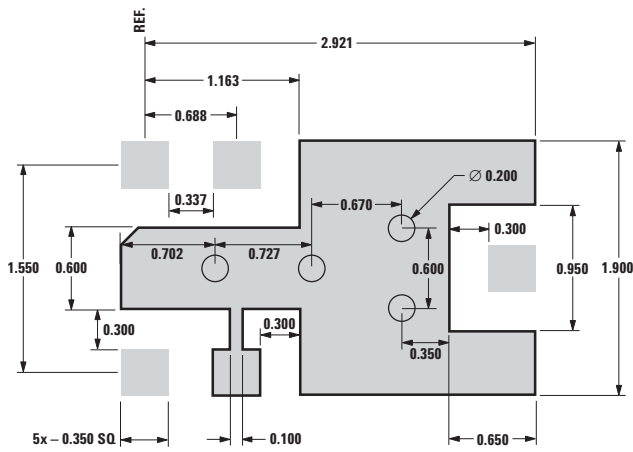

PCB land pattern and suggested grounding vias

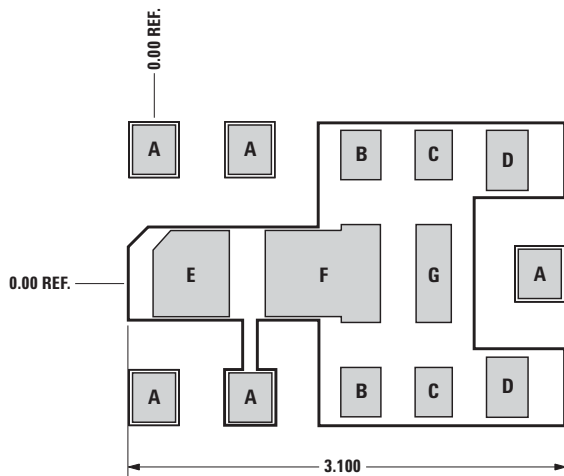
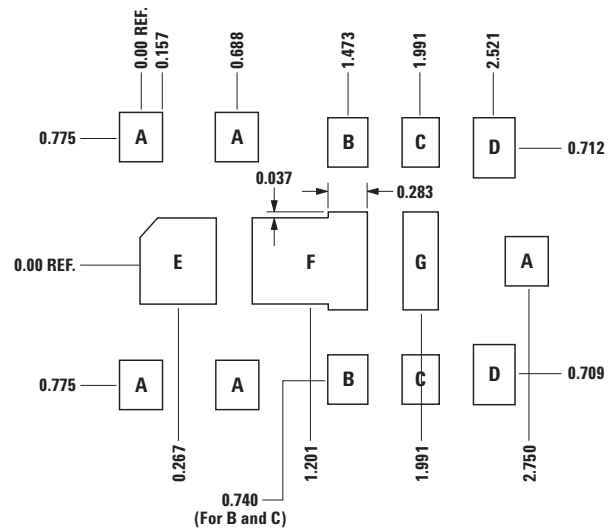

Combined PCB land pattern and stencil outline

A	0.315 (SQUARE)
B	0.280 x 0.306 mm
C	0.257 x 0.306 mm
D	0.303 x 0.367 mm
E	0.544 x 0.492 mm
F	0.824 x 0.618 mm
G	0.257 x 0.617 mm

Stencil outline drawing

Dimensions are in mm

## Device Orientation

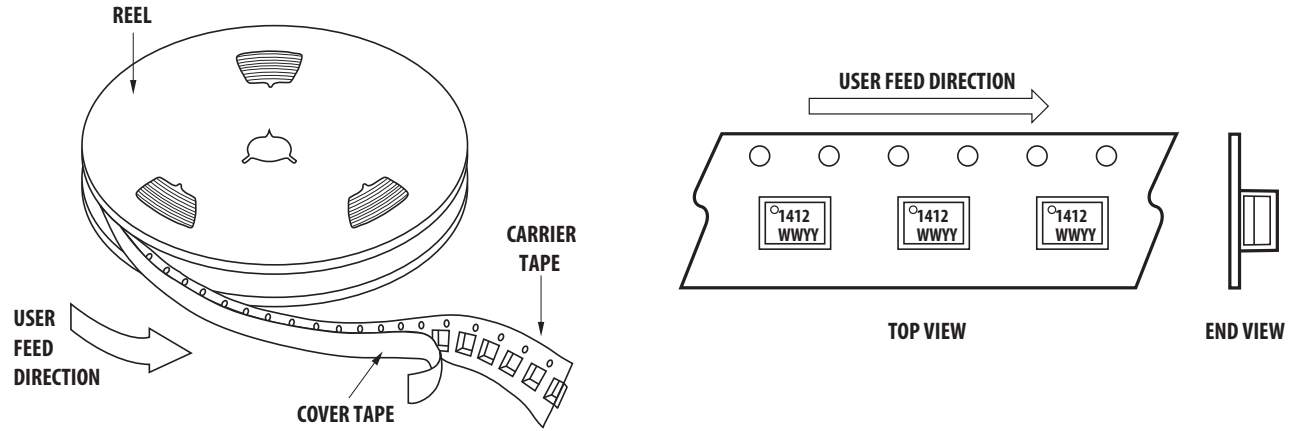

## Tape Dimensions

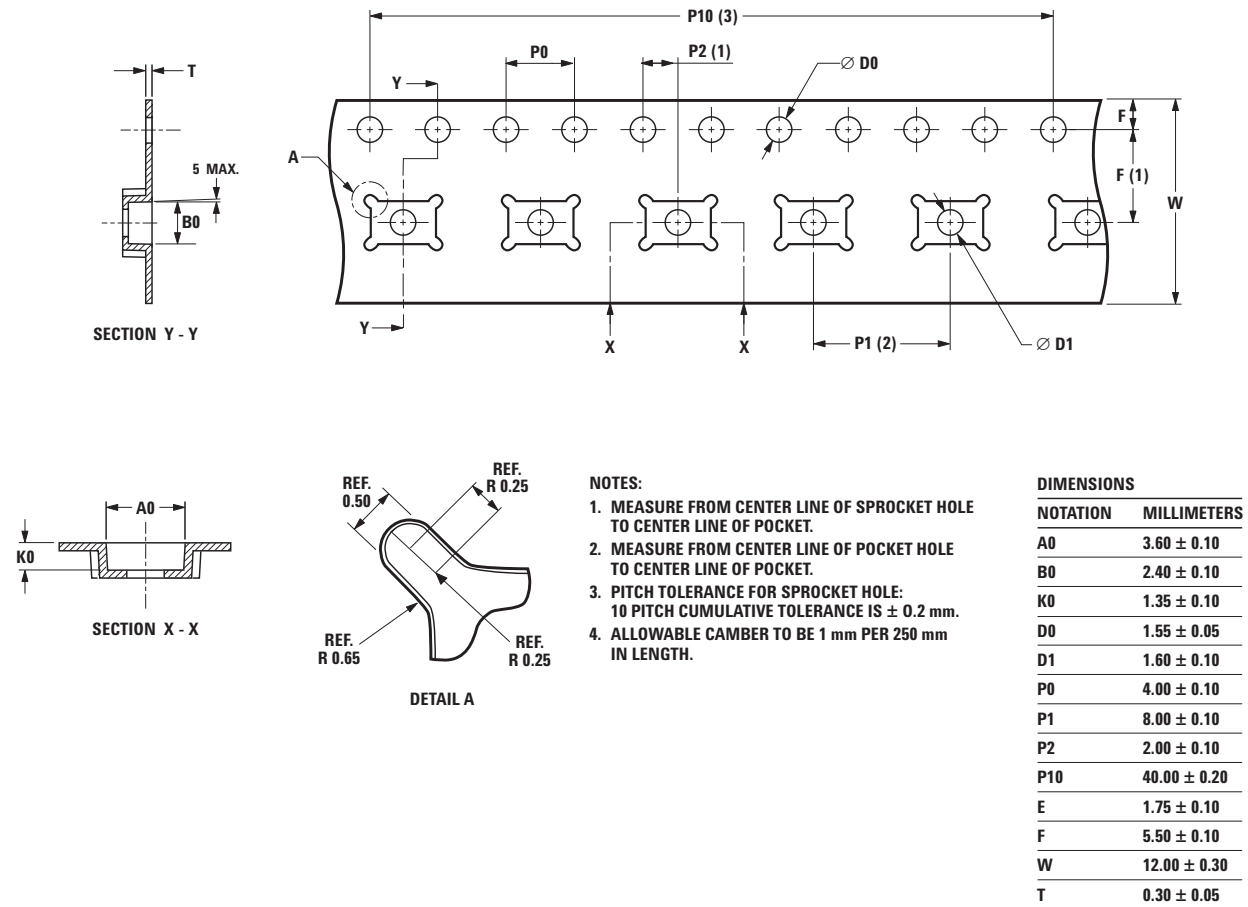

# Reel Dimensions - 13 inch

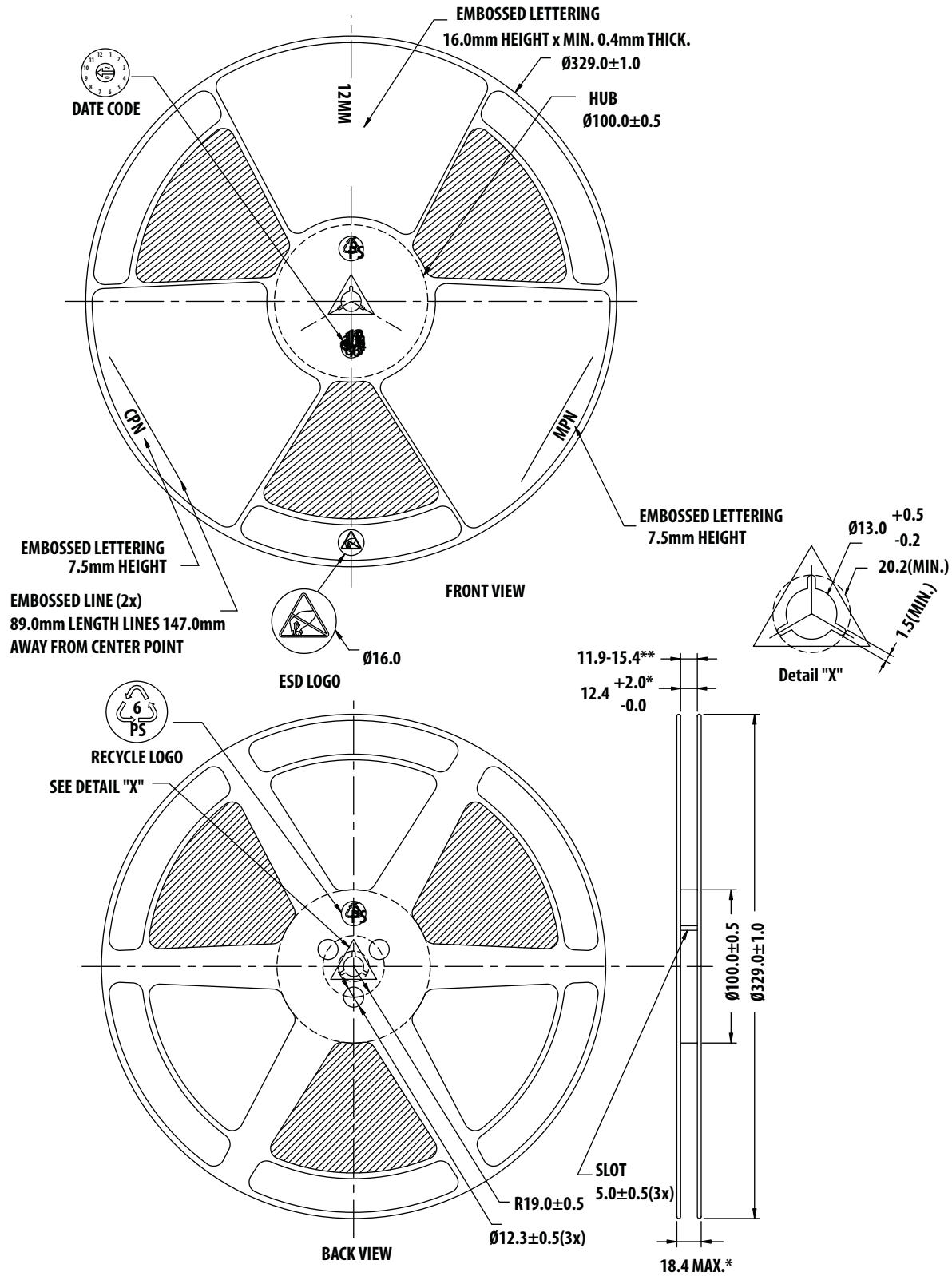

For product information and a complete list of distributors, please go to our website: [www.avagotech.com](http://www.avagotech.com)

Avago, Avago Technologies, and the A logo are trademarks of Avago Technologies in the United States and other countries.  
Data subject to change. Copyright © 2005-2012 Avago Technologies. All rights reserved.  
AV02-0205EN - March 2, 2012



## Looking for pricing, stock, or lifecycle information?

Click below to explore more details on WIN SOURCE:

 [View ALM-1412-TR1G on WIN SOURCE](#)

 [Broadcom Limited](#) Information

## Optimize Your Supply Chain with WIN SOURCE Solutions

-  Global Sourcing Solution
-  Obsolete Management
-  Cost Control Management
-  Shortage Management
-  Alternative Solution
-  Excess Inventory Management