



# THE DATASHEET OF LM25101ASD/NOPB



## LM25101 3-A, 2-A, and 1-A 80-V Half-Bridge Gate Drivers

### 1 Features

- Independent High and Low Driver Logic Inputs
- Bootstrap Supply Voltage up to 100-V DC
- Drives Both a High-Side and Low-Side N-Channel MOSFETs
- Fast Propagation Times (25 ns Typical)
- Drives 1000-pF Load With 8-ns Rise and Fall Times
- Excellent Propagation Delay Matching (3 ns Typical)
- Supply Rail Undervoltage Lockout
- Low Power Consumption
- Pin Compatible With HIP2100 and HIP2101

### 2 Applications

- Motor-Controlled Drivers
- Half and Full Bridge Power Converters
- Synchronous Buck Converters
- Two Switch Forward Power Converters
- Forward With Active Clamp Converters
- 48-V Server Power
- Solar DC-DC and DC-AC Converters

### 3 Description

The LM25101 high-voltage gate driver is designed to drive both the high-side and the low-side N-Channel MOSFETs in a synchronous buck or a half-bridge configuration. The A version provides a full 3-A of gate drive while the B and C versions provide 2-A and 1-A, respectively. The outputs are independently controlled with TTL input thresholds. An integrated high voltage diode is provided to charge the high-side gate drive bootstrap capacitor. A robust level shifter operates at high speed while consuming low power and providing clean level transitions from the control logic to the high-side gate driver. Undervoltage lockout is provided on both the low-side and the high-side power rails.

These devices are available in the standard 8-pin SOIC, 8-pin SO-PowerPAD, 8-pin WSON, 10-pin WSON, and 8-pin MSOP PowerPAD packages.

#### Device Information<sup>(1)</sup>

PART NUMBER	PACKAGE	BODY SIZE (NOM)
LM25101	MSOP PowerPAD (8)	3 mm x 3 mm
	WSON (8)	4 mm x 4 mm
	WSON (10)	4 mm x 4 mm
	SO PowerPAD (8)	3.9 mm x 4.89 mm
	SOIC (8)	3.91 mm x 4.9 mm

(1) For all available packages, see the orderable addendum at the end of the data sheet.

#### Simplified Application Diagram

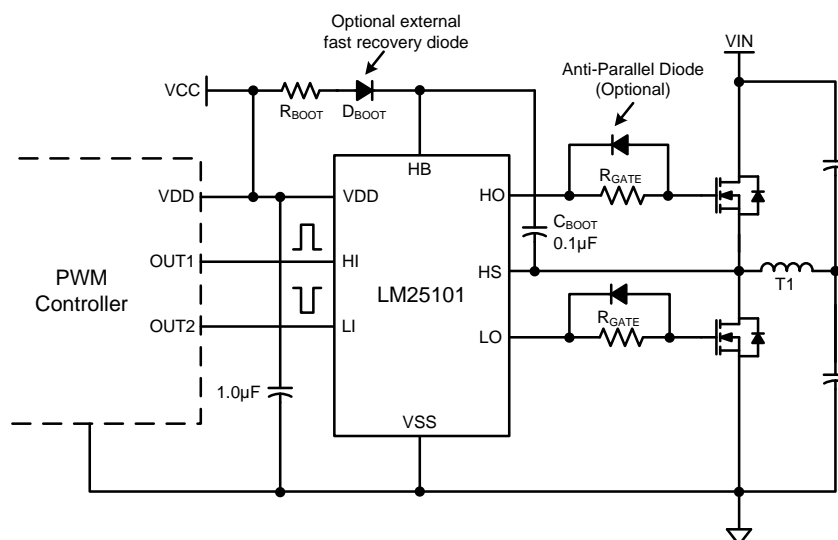

Copyright © 2016, Texas Instruments Incorporated



## Table of Contents

<b>1 Features</b> ..... 1 <b>2 Applications</b> ..... 1 <b>3 Description</b> ..... 1 <b>4 Revision History</b> ..... 2 <b>5 Device Options</b> ..... 3 <b>6 Pin Configuration and Functions</b> ..... 3 <b>7 Specifications</b> ..... 4 7.1 Absolute Maximum Ratings ..... 4 7.2 ESD Ratings ..... 5 7.3 Recommended Operating Conditions ..... 5 7.4 Thermal Information ..... 5 7.5 Electrical Characteristics ..... 6 7.6 Switching Characteristics ..... 7 7.7 Typical Characteristics ..... 8 <b>8 Detailed Description</b> ..... 12 8.1 Overview ..... 12 8.2 Functional Block Diagram ..... 12	8.3 Feature Description ..... 12 8.4 Device Functional Modes ..... 13 <b>9 Application and Implementation</b> ..... 14 9.1 Application Information ..... 14 9.2 Typical Application ..... 14 <b>10 Power Supply Recommendations</b> ..... 16 <b>11 Layout</b> ..... 17 11.1 Layout Guidelines ..... 17 11.2 Layout Example ..... 18 <b>12 Device and Documentation Support</b> ..... 19 12.1 Receiving Notification of Documentation Updates ..... 19 12.2 Community Resources ..... 19 12.3 Trademarks ..... 19 12.4 Electrostatic Discharge Caution ..... 19 12.5 Glossary ..... 19 <b>13 Mechanical, Packaging, and Orderable Information</b> ..... 19
---	--

## 4 Revision History

NOTE: Page numbers for previous revisions may differ from page numbers in the current version.

<b>Changes from Revision B (March 2013) to Revision C</b>	<b>Page</b>
<ul style="list-style-type: none"> <li>• Added <i>ESD Ratings</i> table, <i>Feature Description</i> section, <i>Device Functional Modes</i>, <i>Application and Implementation</i> section, <i>Power Supply Recommendations</i> section, <i>Layout</i> section, <i>Device and Documentation Support</i> section, and <i>Mechanical, Packaging, and Orderable Information</i> section. .... 1</li> <li>• Added <i>Thermal Information</i> table ..... 5</li> </ul>	

<b>Changes from Original (March 2013) to Revision A</b>	<b>Page</b>
<ul style="list-style-type: none"> <li>• Changed layout of National Semiconductor Data Sheet to TI format ..... 1</li> </ul>	

## 5 Device Options

**Table 1. Input/Output Options**

Part Number	Input Thresholds	Peak Output Current
LM25101A	TTL	3 A
LM25101B	TTL	2 A
LM25101C	TTL	1 A

## 6 Pin Configuration and Functions

**DGN and DDA Packages**  
**8-Pin MSOP and SO PowerPAD**  
**Top View**

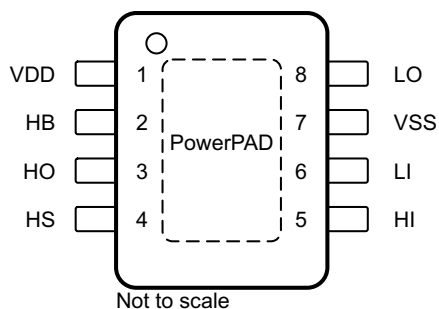

**D Package**  
**8-Pin SOIC**  
**Top View**

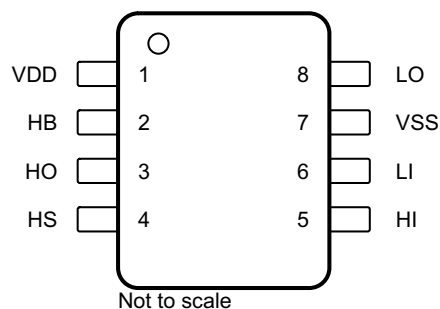

**NGT Package**  
**8-Pin WSON**  
**Top View**

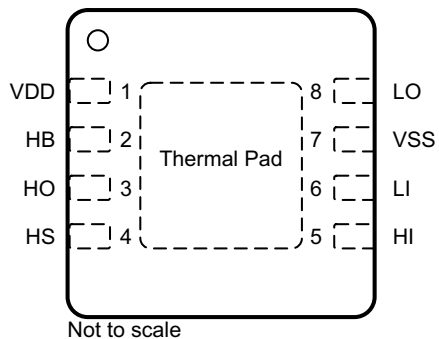

**DPR Package**  
**10-Pin WSON**  
**Top View**

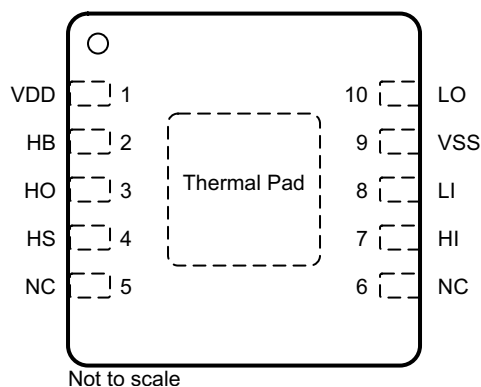

### Pin Functions

NAME	PIN					TYPE	DESCRIPTION
	MSOP PowerPAD	WSON (8)	WSON (10)	SO PowerPAD	SOIC		
HB	2	2	2	2	2	PWR	High-side gate driver bootstrap rail. Connect the positive terminal of the bootstrap capacitor to HB and the negative terminal to HS. The bootstrap capacitor should be placed as close to the IC as possible.
HI	5	5	7	5	5	I	High-side driver control input. The LM25101 inputs have TTL type thresholds. Unused inputs should be tied to ground and not left open.
HO	3	3	3	3	3	O	High-side gate driver output. Connect to the gate of high-side MOSFET with a short, low inductance path.
HS	4	4	4	4	4	GND	High-side MOSFET source connection. Connect to the bootstrap capacitor negative terminal and the source of the high-side MOSFET.
LI	6	6	8	6	6	I	Low-side driver control input. The LM25101 inputs have TTL type thresholds. Unused inputs should be tied to ground and not left open.
LO	8	8	10	8	8	O	Low-side gate driver output. Connect to the gate of the low-side MOSFET with a short, low inductance path.
NC	—	—	5, 6	—	—	—	No connection
VDD	1	1	1	1	1	PWR	Positive gate drive supply. Locally decouple to VSS using a low ESR and ESL capacitor located as close to the IC as possible.
VSS	7	7	9	7	7	GND	Ground return. All signals are referenced to this ground.
Thermal Pad	PowerPAD	Thermal Pad	Thermal Pad	PowerPAD	—	—	Solder to the ground plane under the IC to aid in heat dissipation. <sup>(1)</sup>

(1) TI recommends that the exposed thermal pad on the bottom of the applicable packages is soldered to ground plane of the PCB, and the ground plane should extend out from beneath the IC to help dissipate heat.

## 7 Specifications

### 7.1 Absolute Maximum Ratings

over operating free-air temperature range (unless otherwise noted)<sup>(1)</sup>

	MIN	MAX	UNIT
VDD to VSS	-0.3	18	V
HB to HS	-0.3	18	V
LI or HI Input	-0.3	$V_{DD} + 0.3$	V
LO Output	-0.3	$V_{DD} + 0.3$	V
HO Output	$V_{HS} - 0.3$	$V_{HB} + 0.3$	V
HS to VSS <sup>(2)</sup>	-5	100	V
HB to VSS		100	V
Junction temperature, $T_J$		150	°C
Storage temperature, $T_{stg}$	-55	150	°C

- (1) Stresses beyond those listed under *Absolute Maximum Ratings* may cause permanent damage to the device. These are stress ratings only, which do not imply functional operation of the device at these or any other conditions beyond those indicated under *Recommended Operating Conditions*. Exposure to absolute-maximum-rated conditions for extended periods may affect device reliability. For performance limits and associated test conditions, see the *Electrical Characteristics* tables.
- (2) In the application the HS node is clamped by the body diode of the external lower N-MOSFET, therefore the HS node will generally not exceed -1 V. However, in some applications, board resistance and inductance may result in the HS node exceeding this stated voltage transiently. If negative transients occur, the HS voltage must never be more negative than  $V_{DD} - 15$  V. For example, if  $V_{DD} = 10$  V, the negative transients at HS must not exceed -5 V.

## 7.2 ESD Ratings

			VALUE	UNIT	
V <sub>(ESD)</sub>	Electrostatic discharge	Human-body model (HBM), per ANSI/ESDA/JEDEC JS-001 <sup>(1)</sup>	All pins except 2, 3, and 4	±2000	V
			Pins 2, 3, and 4	±1000	
		Charged-device model (CDM), per JEDEC specification JESD22-C101 <sup>(2)</sup>		±250	
		Machine model (MM)		±100	

(1) The Human Body Model (HBM) is a 100-pF capacitor discharged through a 1.5-kΩ resistor into each pin.

(2) JEDEC document JEP157 states that 250-V CDM allows safe manufacturing with a standard ESD control process.

## 7.3 Recommended Operating Conditions

over operating free-air temperature range (unless otherwise noted)

			MIN	MAX	UNIT
V <sub>DD</sub>	Supply voltage	VDD	9	14	V
V <sub>HS</sub>	Voltage	HS	-1	100 - V <sub>DD</sub>	V
V <sub>HB</sub>	Voltage	HB	V <sub>HS</sub> + 8	V <sub>HS</sub> + 14	V
HS slew rate				50	V/ns
T <sub>J</sub>	Junction temperature		-40	125	°C

## 7.4 Thermal Information

THERMAL METRIC <sup>(1)</sup>	LM25101A, LM25101B				LM25101C			UNIT	
	D (SOIC)	DDA (SO PowerPAD)	NGT (WSON)	DPR (WSON)	D (SOIC)	DPR (WSON)	DGN (MSOP PowerPAD)		
	8 PINS	8 PINS	8 PINS	10 PINS	8 PINS	10 PINS	8 PINS		
R <sub>θJA</sub>	Junction-to-ambient thermal resistance	108.2	46.1	38.2	37.8	111.5	39.8	54.1	°C/W
R <sub>θJC(top)</sub>	Junction-to-case (top) thermal resistance	50.6	53.5	36.3	35.8	54.2	39.1	55.9	°C/W
R <sub>θJB</sub>	Junction-to-board thermal resistance	49.1	13.8	15.2	15.0	52.3	17.1	15.1	°C/W
ψ <sub>JT</sub>	Junction-to-top characterization parameter	7.6	4.2	0.3	0.3	9.0	0.4	2.4	°C/W
ψ <sub>JB</sub>	Junction-to-board characterization parameter	48.5	13.9	15.4	15.3	51.7	17.3	15.1	°C/W
R <sub>θJC(bot)</sub>	Junction-to-case (bottom) thermal resistance	—	3.9	4.5	4.4	—	6.1	4.6	°C/W

(1) For more information about traditional and new thermal metrics, see the [Semiconductor and IC Package Thermal Metrics](#) application report.

## 7.5 Electrical Characteristics

Typical values apply for  $T_J = 25^\circ\text{C}$  only. Minimum and maximum limits apply for  $T_J = -40^\circ\text{C}$  to  $125^\circ\text{C}$ .<sup>(1)</sup> Unless otherwise specified,  $V_{DD} = V_{HB} = 12\text{ V}$ ,  $V_{SS} = V_{HS} = 0\text{ V}$ , No Load on LO or HO.

PARAMETER		TEST CONDITIONS	MIN	TYP	MAX	UNIT
<b>SUPPLY CURRENTS</b>						
$I_{DD}$	VDD quiescent current	$V_{LI} = V_{HI} = 0\text{ V}$		0.25	0.4	mA
$I_{DDO}$	VDD operating current	$f = 500\text{ kHz}$		2.0	3	mA
$I_{HB}$	Total HB quiescent current	$V_{LI} = V_{HI} = 0\text{ V}$		0.06	0.2	mA
$I_{HBO}$	Total HB operating current	$f = 500\text{ kHz}$		1.6	3	mA
$I_{HBS}$	HB to VSS current (quiescent)	$V_{HS} = V_{HB} = 100\text{ V}$		0.1	10	$\mu\text{A}$
$I_{HBSO}$	HB to VSS current (operating)	$f = 500\text{ kHz}$		0.4		mA
<b>INPUT PINS</b>						
$V_{IL}$	Input voltage threshold	Rising Edge	1.3	1.8	2.3	V
$V_{IHYS}$	Input voltage hysteresis			50		mV
$R_I$	Input pulldown resistance		100	200	400	k $\Omega$
<b>UNDER VOLTAGE PROTECTION</b>						
$V_{DDR}$	VDD rising threshold		6.0	6.9	7.4	V
$V_{DDH}$	VDD threshold hysteresis			0.5		V
$V_{HBR}$	HB rising threshold		5.7	6.6	7.1	V
$V_{HBH}$	HB threshold hysteresis			0.4		V
<b>BOOT STRAP DIODE</b>						
$V_{DL}$	Low-current forward voltage	$I_{VDD-HB} = 100\text{ }\mu\text{A}$		0.52	0.85	V
$V_{DH}$	High-current forward voltage	$I_{VDD-HB} = 100\text{ mA}$		0.8	1	V
$R_D$	Dynamic resistance	$I_{VDD-HB} = 100\text{ mA}$		1.0	1.65	$\Omega$
<b>LO AND HO GATE DRIVER</b>						
$V_{OL}$	Low-level output voltage	$I_{HO} = I_{LO} = 100\text{ mA}$	A version	0.12	0.25	V
			B version	0.16	0.4	
			C version	0.28	0.65	
$V_{OH}$	High-level output voltage	$I_{HO} = I_{LO} = 100\text{ mA}$ $V_{OH} = V_{DD} - V_{LO}$ or $V_{OH} = V_{HB} - V_{HO}$	A version	0.24	0.45	V
			B version	0.28	0.60	
			C version	0.60	1.10	
$I_{OHL}$	Peak pullup current	HO, $V_{LO} = 0\text{ V}$	A version	3		A
			B version	2		
			C version	1		
$I_{OLL}$	Peak pulldown current	HO, $V_{LO} = 12\text{ V}$	A version	3		A
			B version	2		
			C version	1		

(1) Minimum and maximum limits are 100% production tested at  $25^\circ\text{C}$ . Limits over the operating temperature range are specified through correlation using Statistical Quality Control (SQC) methods. Limits are used to calculate Average Outgoing Quality Level (AOQL).

## 7.6 Switching Characteristics

Typical values apply for  $T_J = 25^\circ\text{C}$  only. Minimum and maximum limits apply for  $T_J = -40^\circ\text{C}$  to  $125^\circ\text{C}$ .<sup>(1)</sup> Unless otherwise specified,  $V_{DD} = V_{HB} = 12\text{ V}$ ,  $V_{SS} = V_{HS} = 0\text{ V}$ , No Load on LO or HO.

PARAMETER		TEST CONDITIONS		MIN	TYP	MAX	UNIT
$t_{LPHL}$	LO turnoff propagation delay	LI falling to LO falling			22	56	ns
$t_{LPLH}$	LO turnon propagation delay	LI rising to LO rising			26	56	ns
$t_{HPLH}$	HO turnoff propagation delay	HI falling to HO falling			22	56	ns
$t_{HPLH}$	HO turnon propagation delay	HI rising to HO rising			26	56	ns
$t_{MON}$	Delay matching	LO ON and HO OFF			4	10	ns
$t_{MOFF}$	Delay matching	LO OFF and HO ON			4	10	ns
$t_{RC}, t_{FC}$	Either output rise and fall time	$C_L = 1000\text{ pF}$			8		ns
$t_R$	Output rise time (3 V to 9 V)	$C_L = 0.1\text{ }\mu\text{F}$	A version		430		ns
			B version		570		
			C version		990		
$t_F$	Output fall time (3 V to 9 V)	$C_L = 0.1\text{ }\mu\text{F}$	A version		260		ns
			B version		430		
			C version		715		
$t_{PW}$	Minimum input pulse duration that changes the output				50		ns
$t_{BS}$	Bootstrap diode reverse recovery time	$I_F = 100\text{ mA}$ , $I_R = 100\text{ mA}$			37		ns

(1) Minimum and maximum limits are 100% production tested at  $25^\circ\text{C}$ . Limits over the operating temperature range are specified through correlation using Statistical Quality Control (SQC) methods. Limits are used to calculate Average Outgoing Quality Level (AOQL).

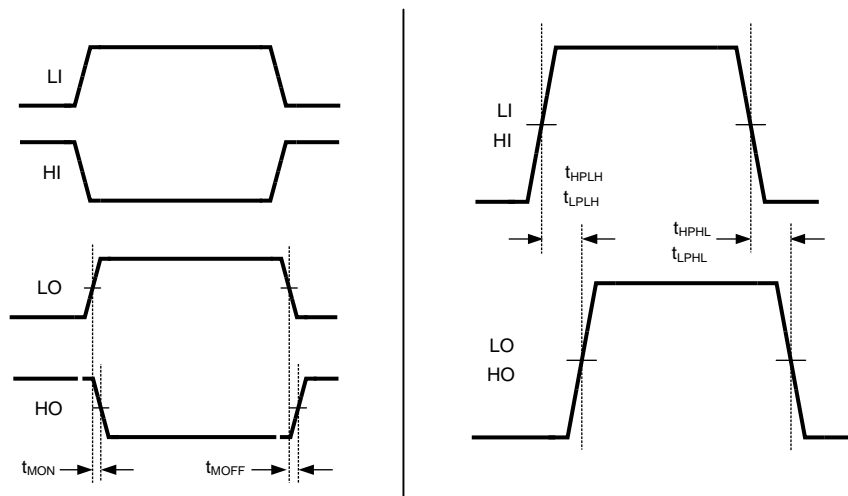

**Figure 1. Timing Diagram**

### 7.7 Typical Characteristics

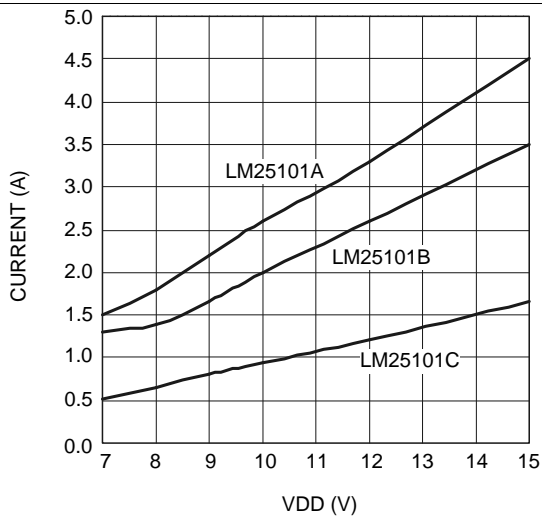

Figure 2. Peak Sourcing Current vs Supply Voltage

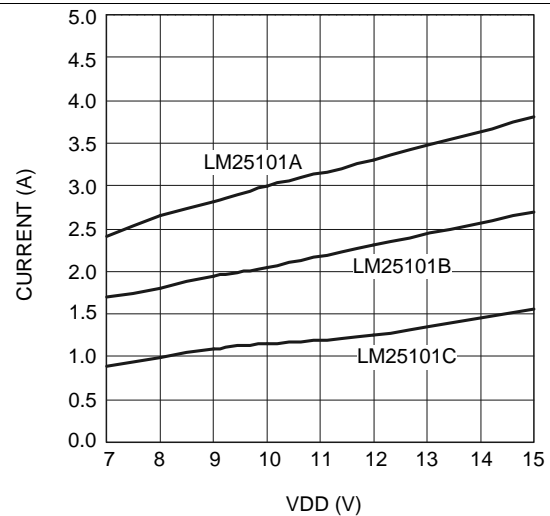

Figure 3. Peak Sinking Current vs Supply Voltage

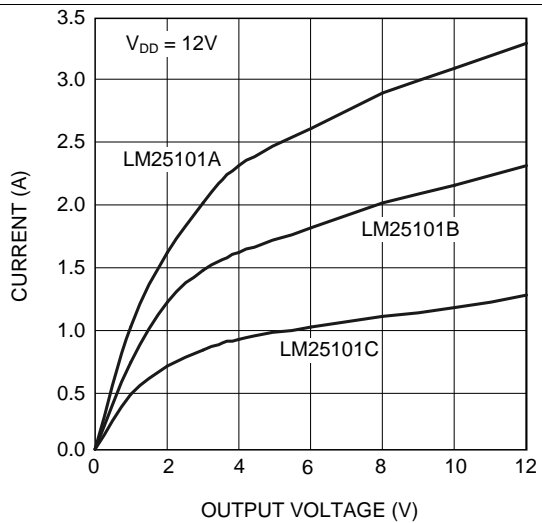

Figure 4. Sink Current vs Output Voltage

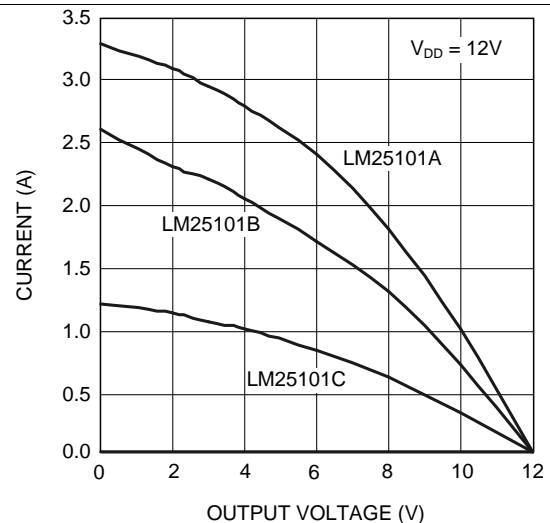

Figure 5. Source Current vs Output Voltage

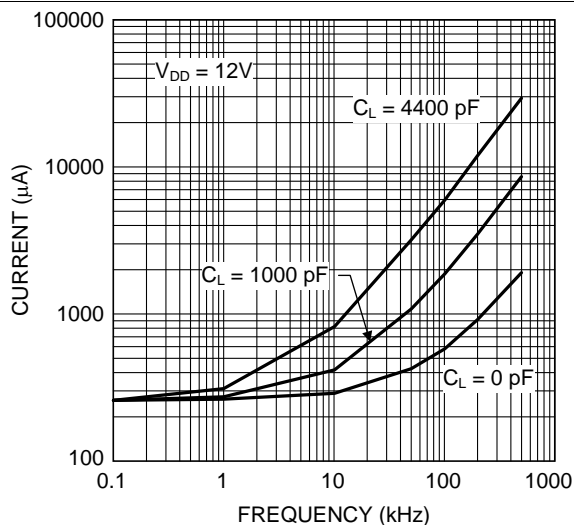

Figure 6.  $I_{DD}$  vs Frequency

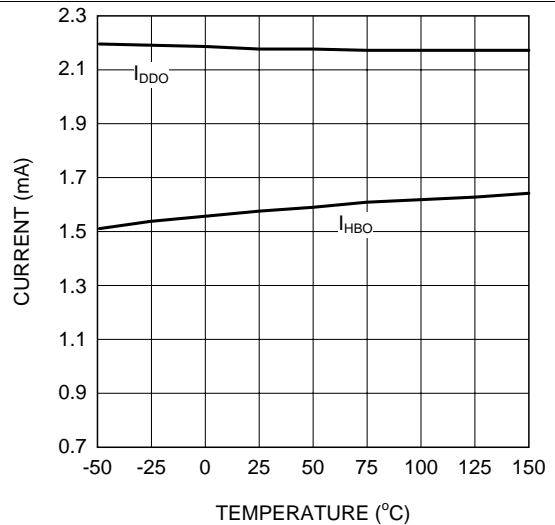

Figure 7. Operating Current vs Temperature

Typical Characteristics (continued)

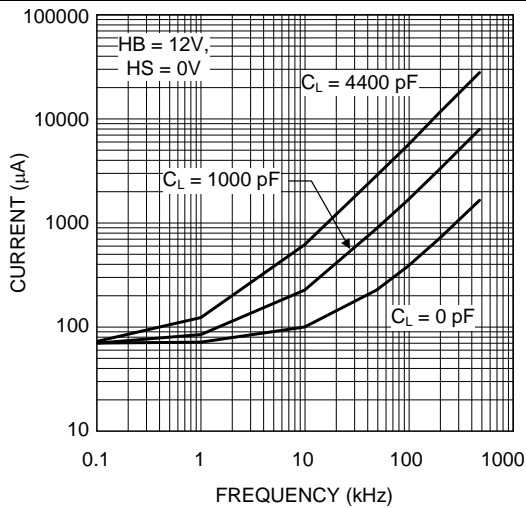

Figure 8.  $I_{HB}$  vs Frequency

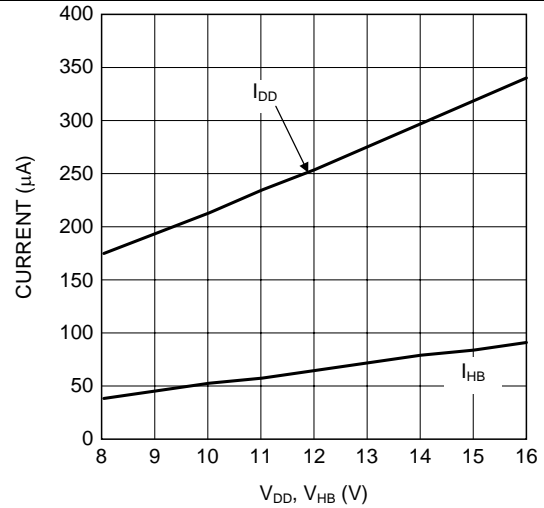

Figure 9. Quiescent Current vs Supply Voltage

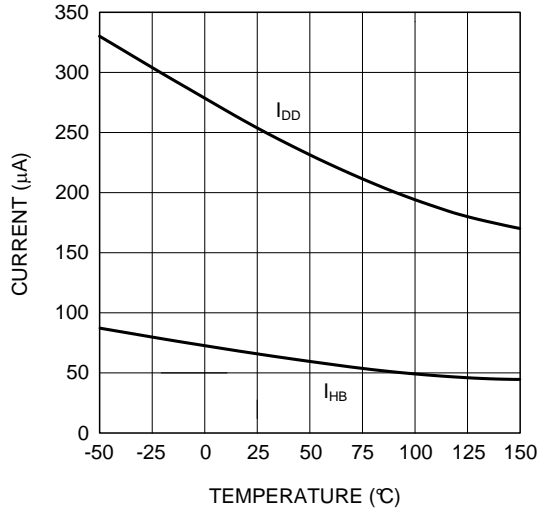

Figure 10. Quiescent Current vs Temperature

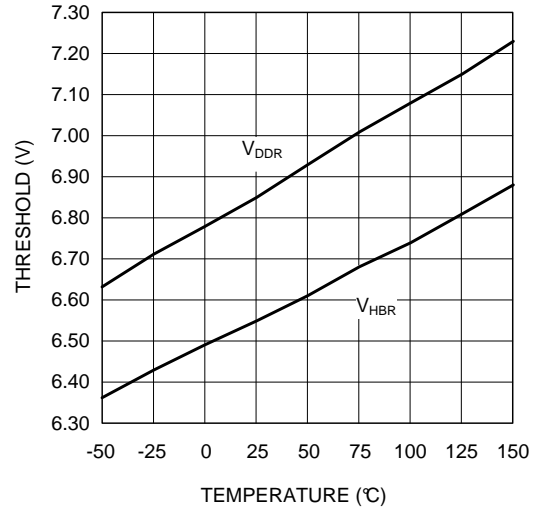

Figure 11. Undervoltage Rising Thresholds vs Temperature

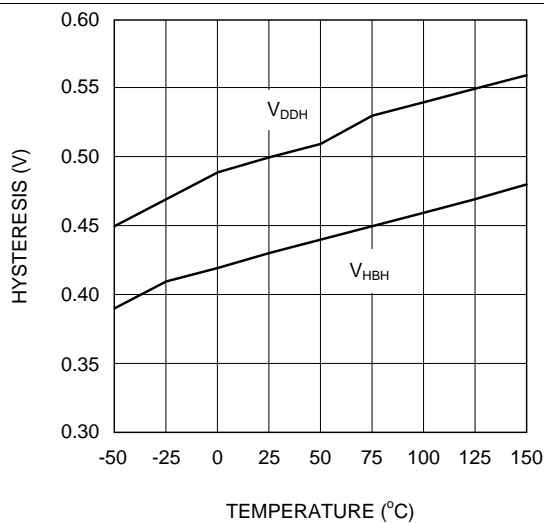

Figure 12. Undervoltage Threshold Hysteresis vs Temperature

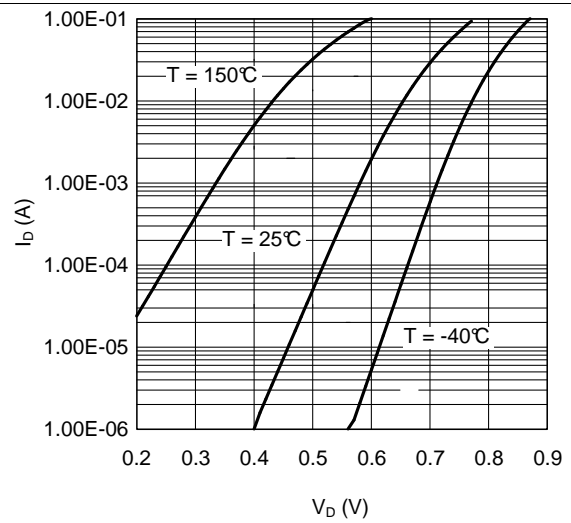

Figure 13. Bootstrap Diode Forward Voltage

Typical Characteristics (continued)

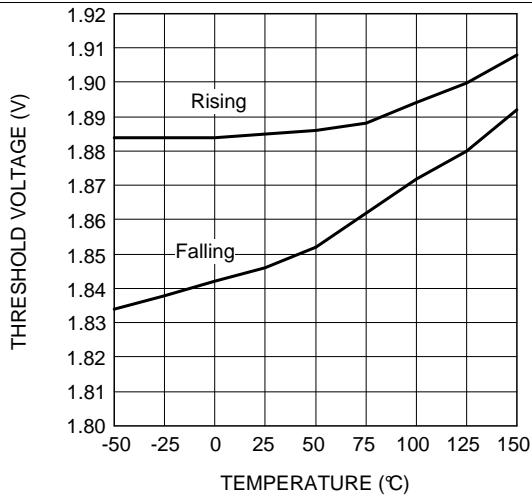

Figure 14. Input Threshold vs Temperature

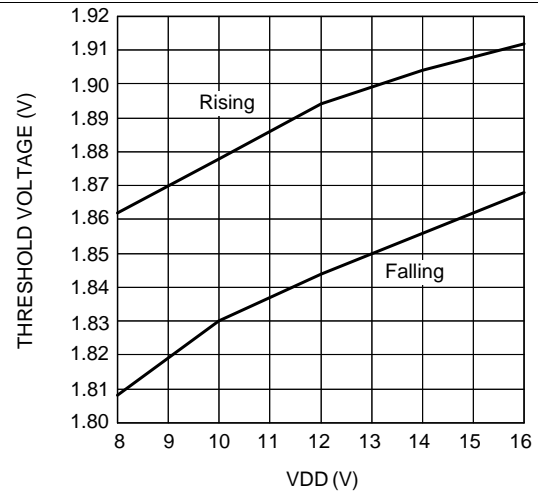

Figure 15. Input Threshold vs Supply Voltage

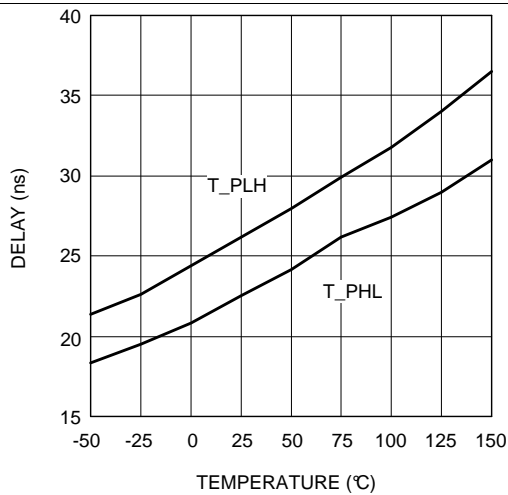

Figure 16. Propagation Delay vs Temperature

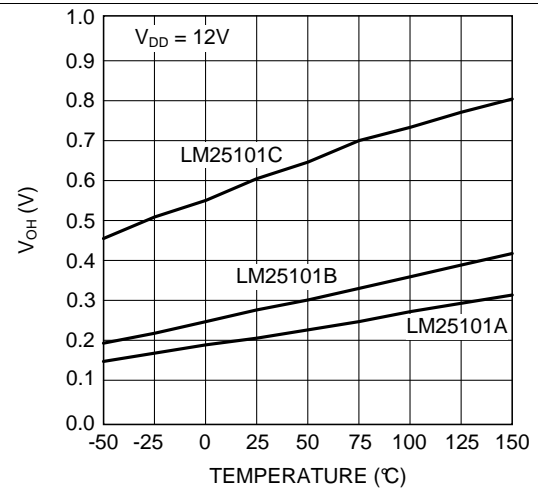

Figure 17. LO and HO Gate Drive: High Level Output Voltage vs Temperature

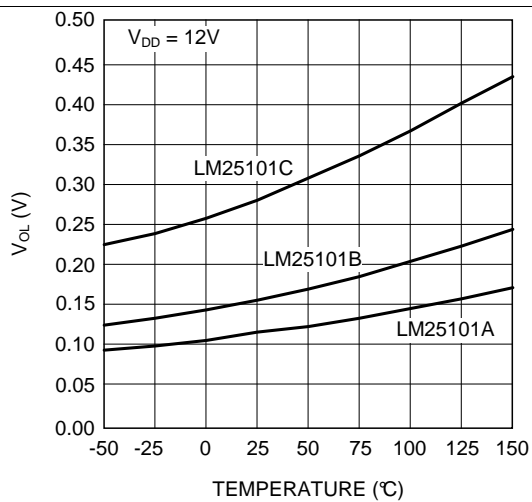

Figure 18. LO and HO Gate Drive: Low Level Output Voltage vs Temperature

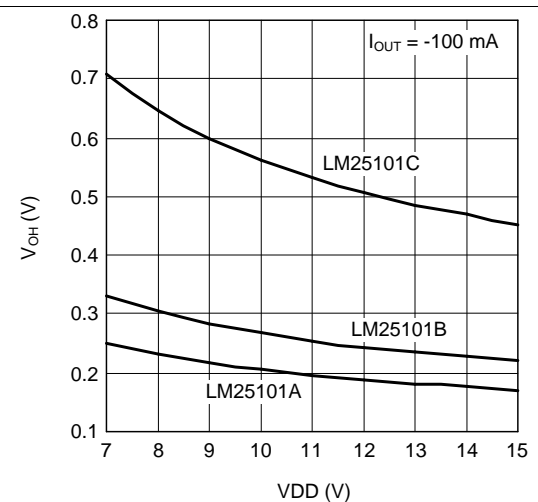

Figure 19. LO and HO Gate Drive: Output High Voltage vs Supply Voltage

Typical Characteristics (continued)

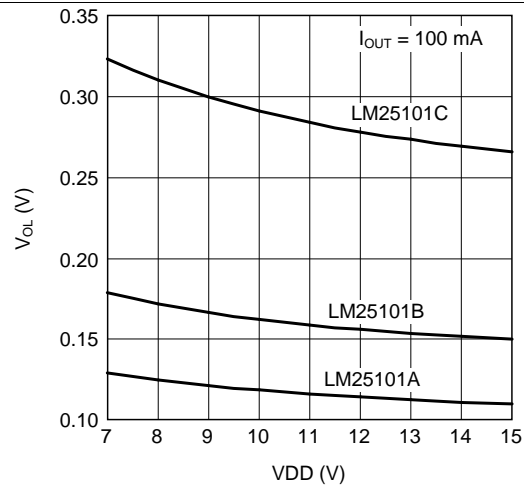

Figure 20. LO and HO Gate Drive:  
Output Low Voltage vs Supply Voltage

## 8 Detailed Description

### 8.1 Overview

To operate fast switching of power MOSFETs at high switching frequencies and to reduce associated switching losses, a powerful gate driver is employed between the PWM output of controller and the gates of the power semiconductor devices. Also, gate drivers are indispensable when it is impossible for the PWM controller to directly drive the gates of the switching devices. With the advent of digital power, this situation is often encountered because the PWM signal from the digital controller is often a 3.3 V logic signal which cannot effectively turn on a power switch. Level shift circuitry is needed to boost the 3.3-V signal to the gate-drive voltage (such as 12 V) in order to fully turn on the power device and minimize conduction losses. Traditional buffer drive circuits based on NPN or PNP bipolar transistors in totem-pole arrangement prove inadequate with digital power because they lack level-shifting capability. Gate drivers effectively combine both the level-shifting and buffer-drive functions. Gate drivers also find other needs such as minimizing the effect of high-frequency switching noise (by placing the high-current driver IC physically close to the power switch), driving gate-drive transformers and controlling floating power-device gates, reducing power dissipation and thermal stress in controllers by moving gate charge power losses from the controller into the driver.

### 8.2 Functional Block Diagram

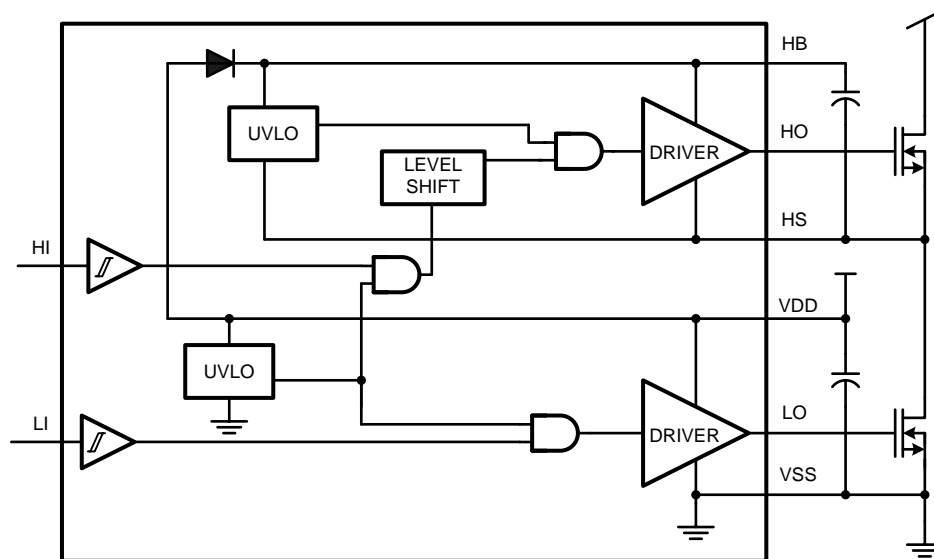

Copyright © 2016, Texas Instruments Incorporated

### 8.3 Feature Description

#### 8.3.1 Start-Up and UVLO

Both top and bottom drivers include UVLO protection circuitry which monitors the supply voltage ( $V_{DD}$ ) and bootstrap capacitor voltage ( $V_{HB-HS}$ ) independently. The UVLO circuit inhibits each output until sufficient supply voltage is available to turn on the external MOSFETs, and the built-in UVLO hysteresis prevents chattering during supply voltage variations. When the supply voltage is applied to the  $V_{DD}$  pin of the LM25101, the top and bottom gates are held low until  $V_{DD}$  exceeds the UVLO threshold, typically about 6.9 V. Any UVLO condition on the bootstrap capacitor ( $V_{HB-HS}$ ) will only disable the high-side output (HO).

**Table 2. VDD UVLO Feature Logic Operation**

CONDITION <sup>(1)</sup>	HI	LI	HO	LO
$V_{DD} - V_{SS} < V_{DDR}$ during device start-up	H	L	L	L
$V_{DD} - V_{SS} < V_{DDR}$ during device start-up	L	H	L	L
$V_{DD} - V_{SS} < V_{DDR}$ during device start-up	H	H	L	L
$V_{DD} - V_{SS} < V_{DDR}$ during device start-up	L	L	L	L
$V_{DD} - V_{SS} < V_{DDR} - V_{DDH}$ after device start-up	H	L	L	L
$V_{DD} - V_{SS} < V_{DDR} - V_{DDH}$ after device start-up	L	H	L	L
$V_{DD} - V_{SS} < V_{DDR} - V_{DDH}$ after device start-up	H	H	L	L
$V_{DD} - V_{SS} < V_{DDR} - V_{DDH}$ after device start-up	L	L	L	L

(1)  $V_{HB-HS} > V_{HBR}$

**Table 3. VHB-HS UVLO Feature Logic Operation**

CONDITION <sup>(1)</sup>	HI	LI	HO	LO
$V_{HB-HS} < V_{HBR}$ during device start-up	H	L	L	L
$V_{HB-HS} < V_{HBR}$ during device start-up	L	H	L	H
$V_{HB-HS} < V_{HBR}$ during device start-up	H	H	L	H
$V_{HB-HS} < V_{HBR}$ during device start-up	L	L	L	L
$V_{HB-HS} < V_{HBR} - V_{HBH}$ after device start-up	H	L	L	L
$V_{HB-HS} < V_{HBR} - V_{HBH}$ after device start-up	L	H	L	H
$V_{HB-HS} < V_{HBR} - V_{HBH}$ after device start-up	H	H	L	H
$V_{HB-HS} < V_{HBR} - V_{HBH}$ after device start-up	L	L	L	L

(1)  $V_{DD} > V_{DDR}$

### 8.3.2 Level Shift

The level shift circuit is the interface from the high-side input to the high-side driver stage which is referenced to the switch node (HS). The level shift allows control of the HO output which is referenced to the HS pin and provides excellent delay matching with the low-side driver.

### 8.3.3 Output Stages

The output stages are the interface to the power MOSFETs in the power train. High slew rate, low resistance, and high peak current capability of both outputs allow for efficient switching of the power MOSFETs. The low-side output stage is referenced to VSS and the high-side is referenced to HS.

## 8.4 Device Functional Modes

The device operates in normal mode and UVLO mode. See [Start-Up and UVLO](#) for more information on UVLO operation mode. In normal mode when the  $V_{DD}$  and  $V_{HB-HS}$  are above UVLO threshold, the output stage is dependent on the states of the HI and LI pins. Unused inputs should be tied to ground and not left open.

**Table 4. INPUT and OUTPUT Logic Table**

HI	LI	HO <sup>(1)</sup>	LO <sup>(2)</sup>
L	L	L	L
L	H	L	H
H	L	H	L
H	H	H	H

(1) HO is measured with respect to the HS pin.

(2) LO is measured with respect to the VSS pin.

## 9 Application and Implementation

### NOTE

Information in the following applications sections is not part of the TI component specification, and TI does not warrant its accuracy or completeness. TI's customers are responsible for determining suitability of components for their purposes. Customers should validate and test their design implementation to confirm system functionality.

### 9.1 Application Information

The LM25101 is a high voltage gate driver designed to drive both the high-side and low-side N-Channel MOSFETs in a half or full bridge configuration or in a synchronous buck circuit. The floating high side driver is capable of operating with supply voltages up to 100 V. This allows for N-Channel MOSFETs control in half-bridge, full-bridge, push-pull, two switch forward, and active clamp topologies. The outputs are independently controlled. Each channel is controlled by its respective input pins (HI and LI), allowing full and independent flexibility to control the state (ON and OFF) of the output.

### 9.2 Typical Application

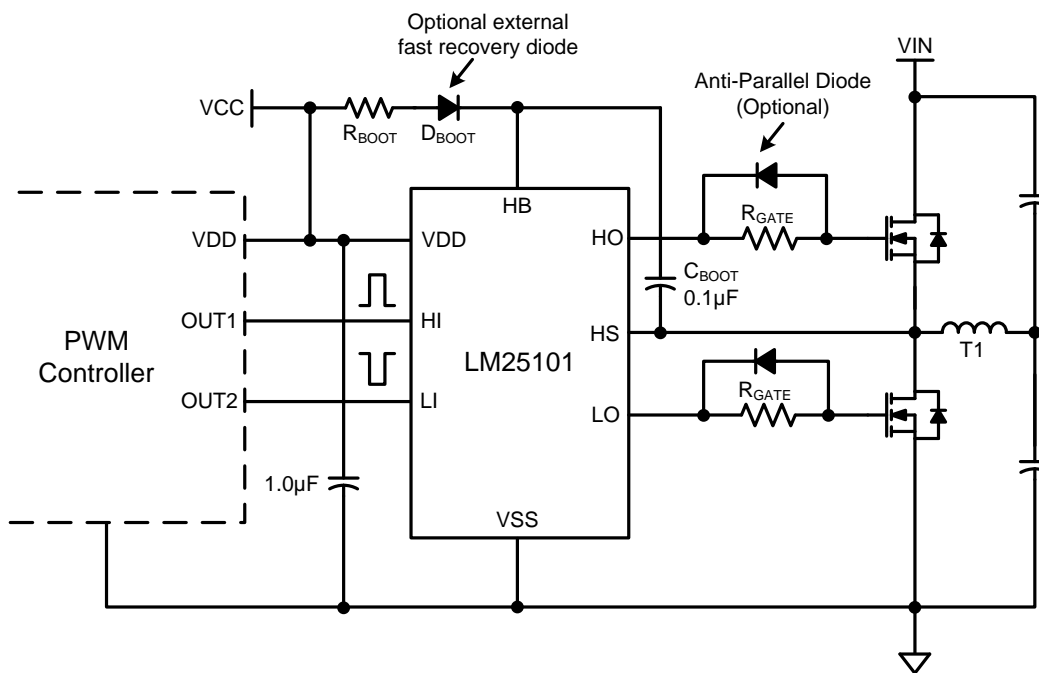

Copyright © 2016, Texas Instruments Incorporated

Figure 21. Application Diagram

#### 9.2.1 Design Requirements

For this design example, use the parameters listed in Table 5 as the input parameters.

Table 5. Design Parameters

PARAMETER	EXAMPLE VALUE
Gate driver	LM25101 (C version)
MOSFET	CSD19534KCS
V <sub>DD</sub>	10 V
Q <sub>G</sub>	17 nC
f <sub>SW</sub>	500 kHz

## 9.2.2 Detailed Design Procedure

### 9.2.2.1 Selecting External Gate Driver Resistor

External gate driver resistor ( $R_{GATE}$ ) is sized to reduce ringing caused by parasitic inductances and capacitances and also to limit the current coming out of the gate driver.

Peak HO pullup current is calculated using [Equation 1](#).

$$I_{OHH} = \frac{V_{DD} - V_{DH}}{R_{HOH} + R_{Gate} + R_{GFET\_Int}} = \frac{10V - 1.0V}{1.1V / 100mA + 4.7\Omega + 2.2\Omega} \approx 0.5A$$

where

- $I_{OHH}$  is the peak pullup current
- $V_{DH}$  is the bootstrap diode forward voltage drop
- $R_{HOH}$  is the gate driver internal HO pullup resistance <sup>(1)</sup>
- $R_{Gate}$  is the external gate drive resistance
- $R_{(GFET\_Int)}$  is the MOSFET internal gate resistance, provided by the transistor data sheet

Similarly, Peak HO pulldown current is calculated using [Equation 2](#).

$$I_{OLH} = \frac{V_{DD} - V_{DH}}{R_{HOL} + R_{Gate} + R_{GFET\_Int}}$$

where

- $R_{HOL}$  is the HO pulldown resistance

Peak LO pullup current is calculated using [Equation 3](#).

$$I_{OHL} = \frac{V_{DD}}{R_{LOH} + R_{Gate} + R_{GFET\_Int}}$$

where

- $R_{LOH}$  is the LO pullup resistance

Peak LO pulldown current is calculated using [Equation 4](#).

$$I_{OLL} = \frac{V_{DD}}{R_{LOL} + R_{Gate} + R_{GFET\_Int}}$$

where

- $R_{LOL}$  is the LO pulldown resistance

If the application requires fast turnoff, an anti-paralleled diode on  $R_{Gate}$  may be used to bypass the external gate drive resistor and speed up the turnoff transition.

(1) This value is either provided directly by the data sheet or is estimated from the testing conditions using  $R_{HOH} = V_{OHH} / I_{HO}$ .

### 9.2.3 Application Curves

Figure 22 and Figure 23 show the rising and falling time and turnon and turnoff propagation delay testing waveform at room temperature. Each channel (HI, LI, HO, LO) is labeled and displayed on the left hand of the waveform.

The HI and LI pins are shorted together for these test waveforms. Therefore, the propagation delay matching between the channels can be measured and inspected.

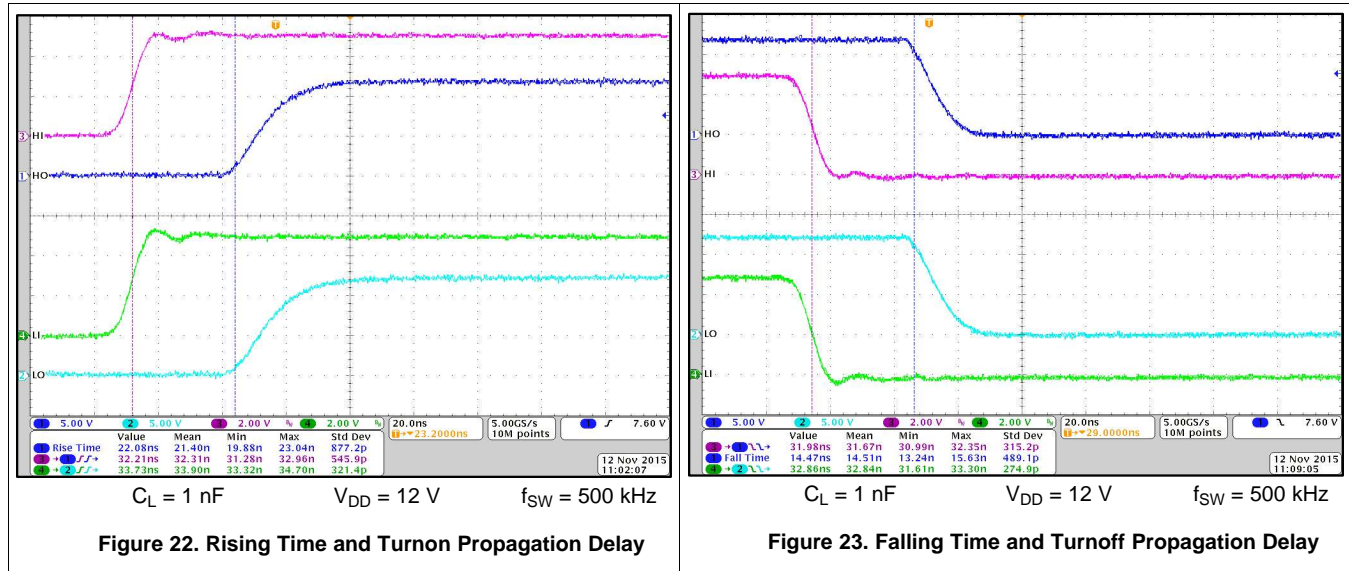

## 10 Power Supply Recommendations

The total IC power dissipation is the sum of the gate driver losses and the bootstrap diode losses. The gate driver losses are related to the switching frequency (f), output load capacitance on LO and HO (C<sub>L</sub>), and supply voltage (V<sub>DD</sub>), which can be roughly calculated using Equation 5.

$$P_{DGATES} = 2 \times f \times C_L \times V_{DD}^2 \tag{5}$$

There are some additional losses in the gate drivers due to the internal CMOS stages used to buffer the LO and HO outputs. Figure 24 shows the measured gate driver power dissipation versus frequency and load capacitance. At higher frequencies and load capacitance values, the power dissipation is dominated by the power losses driving the output loads and agrees well with Equation 5. Figure 24 can be used to approximate the power losses due to the gate drivers.

The bootstrap diode power loss is the sum of the forward bias power loss that occurs while charging the bootstrap capacitor and the reverse bias power loss that occurs during reverse recovery. Since each of these events happens once per cycle, the diode power loss is proportional to frequency. Larger capacitive loads require more energy to recharge the bootstrap capacitor resulting in more losses. Higher input voltages (V<sub>IN</sub>) to the half bridge result in higher reverse recovery losses. Figure 25 was generated based on calculations and lab measurements of the diode recovery time and current under several operating conditions and can be used to approximate the diode power dissipation.

The total IC power dissipation can be estimated from these plots by summing the gate drive losses with the bootstrap diode losses for the intended application.

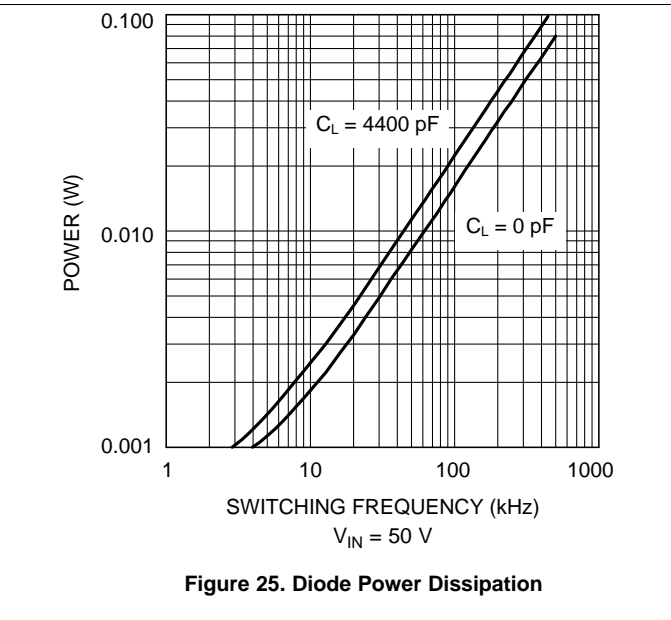
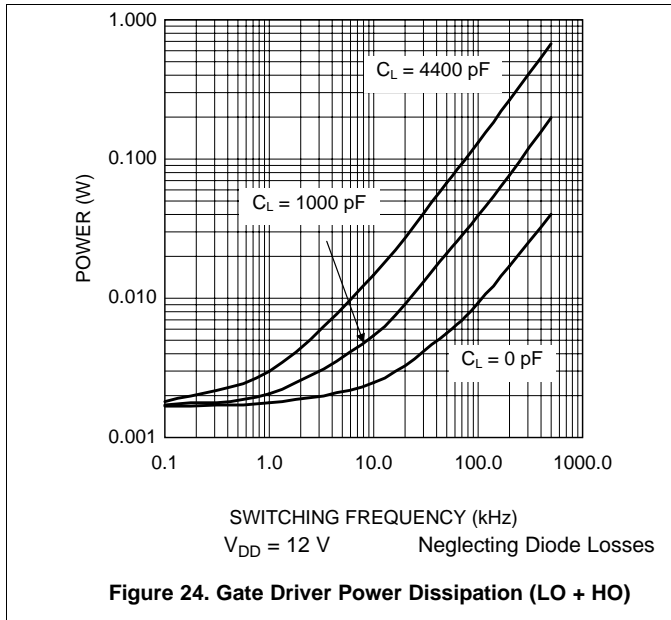

## 11 Layout

### 11.1 Layout Guidelines

The optimum performance of high and low-side gate drivers cannot be achieved without following certain guidelines during circuit-board layout.

- Low ESR and ESL capacitors must be connected close to the IC, between the VDD and VSS pins and between the HB and HS pins to support the high peak currents being drawn from VDD during start-up of the external MOSFET.
- To prevent large voltage transients at the drain of the top MOSFET, a low ESR electrolytic capacitor must be connected between the MOSFET drain and ground (VSS).
- To avoid large negative transients on the switch node (HS pin), the parasitic inductances must be minimized in the source of the top MOSFET and in the drain of the bottom MOSFET (synchronous rectifier).
- Grounding Considerations:
  - The first priority in designing grounding connections is to confine to a minimal physical area the high peak currents that charge and discharge the MOSFET gate. This decreases the loop inductance and minimizes noise issues on the gate terminal of the MOSFET. The MOSFETs should be placed as close as possible to the gate driver.
  - The second high current path includes the bootstrap capacitor, the bootstrap diode, the local ground referenced bypass capacitor, and low-side MOSFET body diode. The bootstrap capacitor is recharged on a cycle-by-cycle basis through the bootstrap diode from the ground referenced VDD bypass capacitor. The recharging occurs in a short time interval and involves high peak current. Minimizing this loop length and area on the circuit board is important to ensure reliable operation.

Figure 26 shows a recommended layout pattern for the driver. If possible a single layer placement is preferred.

## 11.2 Layout Example

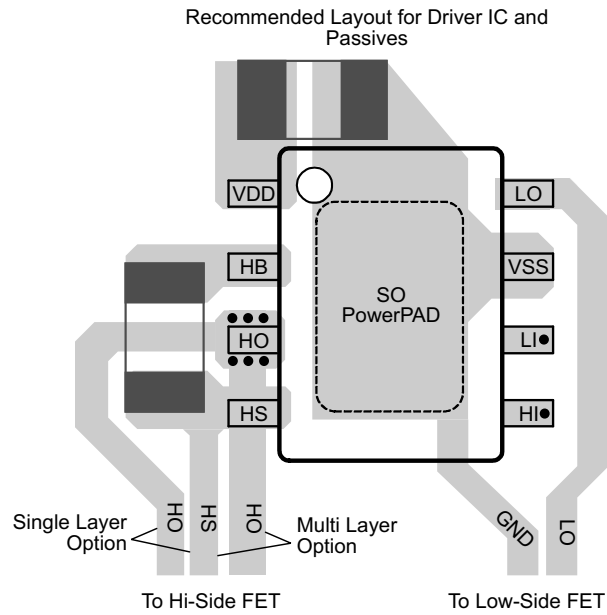

**Figure 26. Recommended Layout Pattern**

## 12 Device and Documentation Support

### 12.1 Receiving Notification of Documentation Updates

To receive notification of documentation updates, navigate to the device product folder on ti.com. In the upper right corner, click on *Alert me* to register and receive a weekly digest of any product information that has changed. For change details, review the revision history included in any revised document.

### 12.2 Community Resources

The following links connect to TI community resources. Linked contents are provided "AS IS" by the respective contributors. They do not constitute TI specifications and do not necessarily reflect TI's views; see TI's [Terms of Use](#).

**TI E2E™ Online Community** *TI's Engineer-to-Engineer (E2E) Community*. Created to foster collaboration among engineers. At e2e.ti.com, you can ask questions, share knowledge, explore ideas and help solve problems with fellow engineers.

**Design Support** *TI's Design Support* Quickly find helpful E2E forums along with design support tools and contact information for technical support.

### 12.3 Trademarks

E2E is a trademark of Texas Instruments.  
All other trademarks are the property of their respective owners.

### 12.4 Electrostatic Discharge Caution



This integrated circuit can be damaged by ESD. Texas Instruments recommends that all integrated circuits be handled with appropriate precautions. Failure to observe proper handling and installation procedures can cause damage.

ESD damage can range from subtle performance degradation to complete device failure. Precision integrated circuits may be more susceptible to damage because very small parametric changes could cause the device not to meet its published specifications.

### 12.5 Glossary

[SLYZ022](#) — *TI Glossary*.



This glossary lists and explains terms, acronyms, and definitions.

## 13 Mechanical, Packaging, and Orderable Information

The following pages include mechanical, packaging, and orderable information. This information is the most current data available for the designated devices. This data is subject to change without notice and revision of this document. For browser-based versions of this data sheet, refer to the left-hand navigation.

**PACKAGING INFORMATION**

Orderable Device	Status (1)	Package Type	Package Drawing	Pins	Package Qty	Eco Plan (2)	Lead/Ball Finish (6)	MSL Peak Temp (3)	Op Temp (°C)	Device Marking (4/5)	Samples
LM25101AM/NOPB	ACTIVE	SOIC	D	8	95	Green (RoHS & no Sb/Br)	CU SN	Level-1-260C-UNLIM	-40 to 125	L25101 AM	<a href="#">Samples</a>
LM25101AMR/NOPB	ACTIVE	SO PowerPAD	DDA	8	95	Green (RoHS & no Sb/Br)	CU SN	Level-3-260C-168 HR	-40 to 125	L25101 AMR	<a href="#">Samples</a>
LM25101AMRX/NOPB	ACTIVE	SO PowerPAD	DDA	8	2500	Green (RoHS & no Sb/Br)	CU SN	Level-3-260C-168 HR	-40 to 125	L25101 AMR	<a href="#">Samples</a>
LM25101AMX/NOPB	ACTIVE	SOIC	D	8	2500	Green (RoHS & no Sb/Br)	CU SN	Level-1-260C-UNLIM	-40 to 125	L25101 AM	<a href="#">Samples</a>
LM25101ASD-1/NOPB	ACTIVE	WSON	NGT	8	1000	Green (RoHS & no Sb/Br)	CU SN	Level-1-260C-UNLIM	-40 to 125	25101A1	<a href="#">Samples</a>
LM25101ASD/NOPB	ACTIVE	WSON	DPR	10	1000	Green (RoHS & no Sb/Br)	CU SN	Level-1-260C-UNLIM	-40 to 125	25101A	<a href="#">Samples</a>
LM25101ASDX-1/NOPB	ACTIVE	WSON	NGT	8	4500	Green (RoHS & no Sb/Br)	CU SN	Level-1-260C-UNLIM	-40 to 125	25101A1	<a href="#">Samples</a>
LM25101ASDX/NOPB	ACTIVE	WSON	DPR	10	4500	Green (RoHS & no Sb/Br)	CU SN	Level-1-260C-UNLIM	-40 to 125	25101A	<a href="#">Samples</a>
LM25101BMA/NOPB	ACTIVE	SOIC	D	8	95	Green (RoHS & no Sb/Br)	CU SN	Level-1-260C-UNLIM	-40 to 125	L25101 BMA	<a href="#">Samples</a>
LM25101BMAX/NOPB	ACTIVE	SOIC	D	8	2500	Green (RoHS & no Sb/Br)	CU SN	Level-1-260C-UNLIM	-40 to 125	L25101 BMA	<a href="#">Samples</a>
LM25101BSD/NOPB	ACTIVE	WSON	DPR	10	1000	Green (RoHS & no Sb/Br)	CU SN	Level-1-260C-UNLIM	-40 to 125	25101B	<a href="#">Samples</a>
LM25101BSDX/NOPB	ACTIVE	WSON	DPR	10	4500	Green (RoHS & no Sb/Br)	CU SN	Level-1-260C-UNLIM	-40 to 125	25101B	<a href="#">Samples</a>
LM25101CMA/NOPB	ACTIVE	SOIC	D	8	95	Green (RoHS & no Sb/Br)	CU SN	Level-1-260C-UNLIM	-40 to 125	L25101 CMA	<a href="#">Samples</a>
LM25101CMAX/NOPB	ACTIVE	SOIC	D	8	2500	Green (RoHS & no Sb/Br)	CU SN	Level-1-260C-UNLIM	-40 to 125	L25101 CMA	<a href="#">Samples</a>
LM25101CMY/NOPB	ACTIVE	MSOP-PowerPAD	DGN	8	1000	Green (RoHS & no Sb/Br)	CU SN	Level-1-260C-UNLIM	-40 to 125	CMYN	<a href="#">Samples</a>
LM25101CMYE/NOPB	ACTIVE	MSOP-PowerPAD	DGN	8	250	Green (RoHS & no Sb/Br)	CU SN	Level-1-260C-UNLIM	-40 to 125	CMYN	<a href="#">Samples</a>
LM25101CMYX/NOPB	ACTIVE	MSOP-PowerPAD	DGN	8	3500	Green (RoHS & no Sb/Br)	CU SN	Level-1-260C-UNLIM	-40 to 125	CMYN	<a href="#">Samples</a>

Orderable Device	Status (1)	Package Type	Package Drawing	Pins	Package Qty	Eco Plan (2)	Lead/Ball Finish (6)	MSL Peak Temp (3)	Op Temp (°C)	Device Marking (4/5)	Samples
LM25101CSD/NOPB	ACTIVE	WSON	DPR	10	1000	Green (RoHS & no Sb/Br)	CU SN	Level-1-260C-UNLIM	-40 to 125	25101C	
LM25101CSDX/NOPB	ACTIVE	WSON	DPR	10	4500	Green (RoHS & no Sb/Br)	CU SN	Level-1-260C-UNLIM	-40 to 125	25101C	

(1) The marketing status values are defined as follows:

**ACTIVE:** Product device recommended for new designs.

**LIFEBUY:** TI has announced that the device will be discontinued, and a lifetime-buy period is in effect.

**NRND:** Not recommended for new designs. Device is in production to support existing customers, but TI does not recommend using this part in a new design.

**PREVIEW:** Device has been announced but is not in production. Samples may or may not be available.

**OBSOLETE:** TI has discontinued the production of the device.

(2) **RoHS:** TI defines "RoHS" to mean semiconductor products that are compliant with the current EU RoHS requirements for all 10 RoHS substances, including the requirement that RoHS substance do not exceed 0.1% by weight in homogeneous materials. Where designed to be soldered at high temperatures, "RoHS" products are suitable for use in specified lead-free processes. TI may reference these types of products as "Pb-Free".

**RoHS Exempt:** TI defines "RoHS Exempt" to mean products that contain lead but are compliant with EU RoHS pursuant to a specific EU RoHS exemption.

**Green:** TI defines "Green" to mean the content of Chlorine (Cl) and Bromine (Br) based flame retardants meet JS709B low halogen requirements of <=1000ppm threshold. Antimony trioxide based flame retardants must also meet the <=1000ppm threshold requirement.

(3) MSL, Peak Temp. - The Moisture Sensitivity Level rating according to the JEDEC industry standard classifications, and peak solder temperature.

(4) There may be additional marking, which relates to the logo, the lot trace code information, or the environmental category on the device.

(5) Multiple Device Markings will be inside parentheses. Only one Device Marking contained in parentheses and separated by a "~" will appear on a device. If a line is indented then it is a continuation of the previous line and the two combined represent the entire Device Marking for that device.

(6) Lead/Ball Finish - Orderable Devices may have multiple material finish options. Finish options are separated by a vertical ruled line. Lead/Ball Finish values may wrap to two lines if the finish value exceeds the maximum column width.

**Important Information and Disclaimer:** The information provided on this page represents TI's knowledge and belief as of the date that it is provided. TI bases its knowledge and belief on information provided by third parties, and makes no representation or warranty as to the accuracy of such information. Efforts are underway to better integrate information from third parties. TI has taken and continues to take reasonable steps to provide representative and accurate information but may not have conducted destructive testing or chemical analysis on incoming materials and chemicals. TI and TI suppliers consider certain information to be proprietary, and thus CAS numbers and other limited information may not be available for release.

In no event shall TI's liability arising out of such information exceed the total purchase price of the TI part(s) at issue in this document sold by TI to Customer on an annual basis.

**TAPE AND REEL INFORMATION**

**QUADRANT ASSIGNMENTS FOR PIN 1 ORIENTATION IN TAPE**

\*All dimensions are nominal

Device	Package Type	Package Drawing	Pins	SPQ	Reel Diameter (mm)	Reel Width W1 (mm)	A0 (mm)	B0 (mm)	K0 (mm)	P1 (mm)	W (mm)	Pin1 Quadrant
LM25101AMRX/NOPB	SO Power PAD	DDA	8	2500	330.0	12.4	6.5	5.4	2.0	8.0	12.0	Q1
LM25101AMX/NOPB	SOIC	D	8	2500	330.0	12.4	6.5	5.4	2.0	8.0	12.0	Q1
LM25101ASD-1/NOPB	WSO	NGT	8	1000	178.0	12.4	4.3	4.3	1.3	8.0	12.0	Q1
LM25101ASD/NOPB	WSO	DPR	10	1000	178.0	12.4	4.3	4.3	1.3	8.0	12.0	Q1
LM25101ASDX-1/NOPB	WSO	NGT	8	4500	330.0	12.4	4.3	4.3	1.3	8.0	12.0	Q1
LM25101ASDX/NOPB	WSO	DPR	10	4500	330.0	12.4	4.3	4.3	1.3	8.0	12.0	Q1
LM25101BMAX/NOPB	SOIC	D	8	2500	330.0	12.4	6.5	5.4	2.0	8.0	12.0	Q1
LM25101BSD/NOPB	WSO	DPR	10	1000	178.0	12.4	4.3	4.3	1.3	8.0	12.0	Q1
LM25101BSDX/NOPB	WSO	DPR	10	4500	330.0	12.4	4.3	4.3	1.3	8.0	12.0	Q1
LM25101CMAX/NOPB	SOIC	D	8	2500	330.0	12.4	6.5	5.4	2.0	8.0	12.0	Q1
LM25101CMY/NOPB	MSOP-Power PAD	DGN	8	1000	178.0	12.4	5.3	3.4	1.4	8.0	12.0	Q1
LM25101CMYE/NOPB	MSOP-Power PAD	DGN	8	250	178.0	12.4	5.3	3.4	1.4	8.0	12.0	Q1
LM25101CMYX/NOPB	MSOP-Power	DGN	8	3500	330.0	12.4	5.3	3.4	1.4	8.0	12.0	Q1

Device	Package Type	Package Drawing	Pins	SPQ	Reel Diameter (mm)	Reel Width W1 (mm)	A0 (mm)	B0 (mm)	K0 (mm)	P1 (mm)	W (mm)	Pin1 Quadrant
	PAD											
LM25101CSD/NOPB	WSON	DPR	10	1000	178.0	12.4	4.3	4.3	1.3	8.0	12.0	Q1
LM25101CSDX/NOPB	WSON	DPR	10	4500	330.0	12.4	4.3	4.3	1.3	8.0	12.0	Q1

## TAPE AND REEL BOX DIMENSIONS

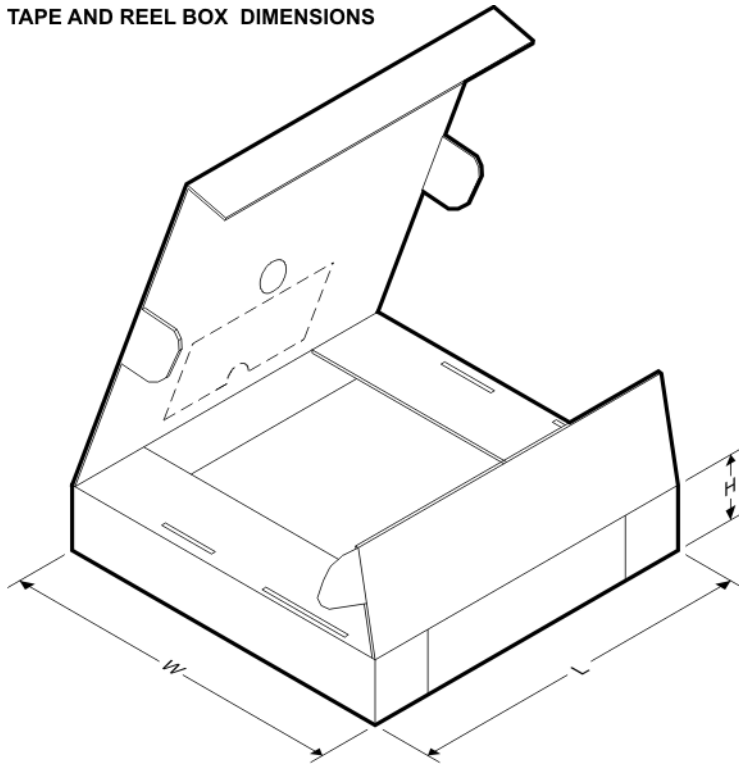

\*All dimensions are nominal

Device	Package Type	Package Drawing	Pins	SPQ	Length (mm)	Width (mm)	Height (mm)
LM25101AMRX/NOPB	SO PowerPAD	DDA	8	2500	367.0	367.0	35.0
LM25101AMX/NOPB	SOIC	D	8	2500	367.0	367.0	35.0
LM25101ASD-1/NOPB	WSON	NGT	8	1000	210.0	185.0	35.0
LM25101ASD/NOPB	WSON	DPR	10	1000	210.0	185.0	35.0
LM25101ASDX-1/NOPB	WSON	NGT	8	4500	367.0	367.0	35.0
LM25101ASDX/NOPB	WSON	DPR	10	4500	367.0	367.0	35.0
LM25101BMAX/NOPB	SOIC	D	8	2500	367.0	367.0	35.0
LM25101BSD/NOPB	WSON	DPR	10	1000	210.0	185.0	35.0
LM25101BSDX/NOPB	WSON	DPR	10	4500	367.0	367.0	35.0
LM25101CMAX/NOPB	SOIC	D	8	2500	367.0	367.0	35.0
LM25101CMY/NOPB	MSOP-PowerPAD	DGN	8	1000	210.0	185.0	35.0
LM25101CMYE/NOPB	MSOP-PowerPAD	DGN	8	250	210.0	185.0	35.0
LM25101CMYX/NOPB	MSOP-PowerPAD	DGN	8	3500	367.0	367.0	35.0
LM25101CSD/NOPB	WSON	DPR	10	1000	210.0	185.0	35.0

---

Device	Package Type	Package Drawing	Pins	SPQ	Length (mm)	Width (mm)	Height (mm)
LM25101CSDX/NOPB	WSON	DPR	10	4500	367.0	367.0	35.0

# DDA0008B



# PACKAGE OUTLINE

## PowerPAD™ SOIC - 1.7 mm max height

PLASTIC SMALL OUTLINE

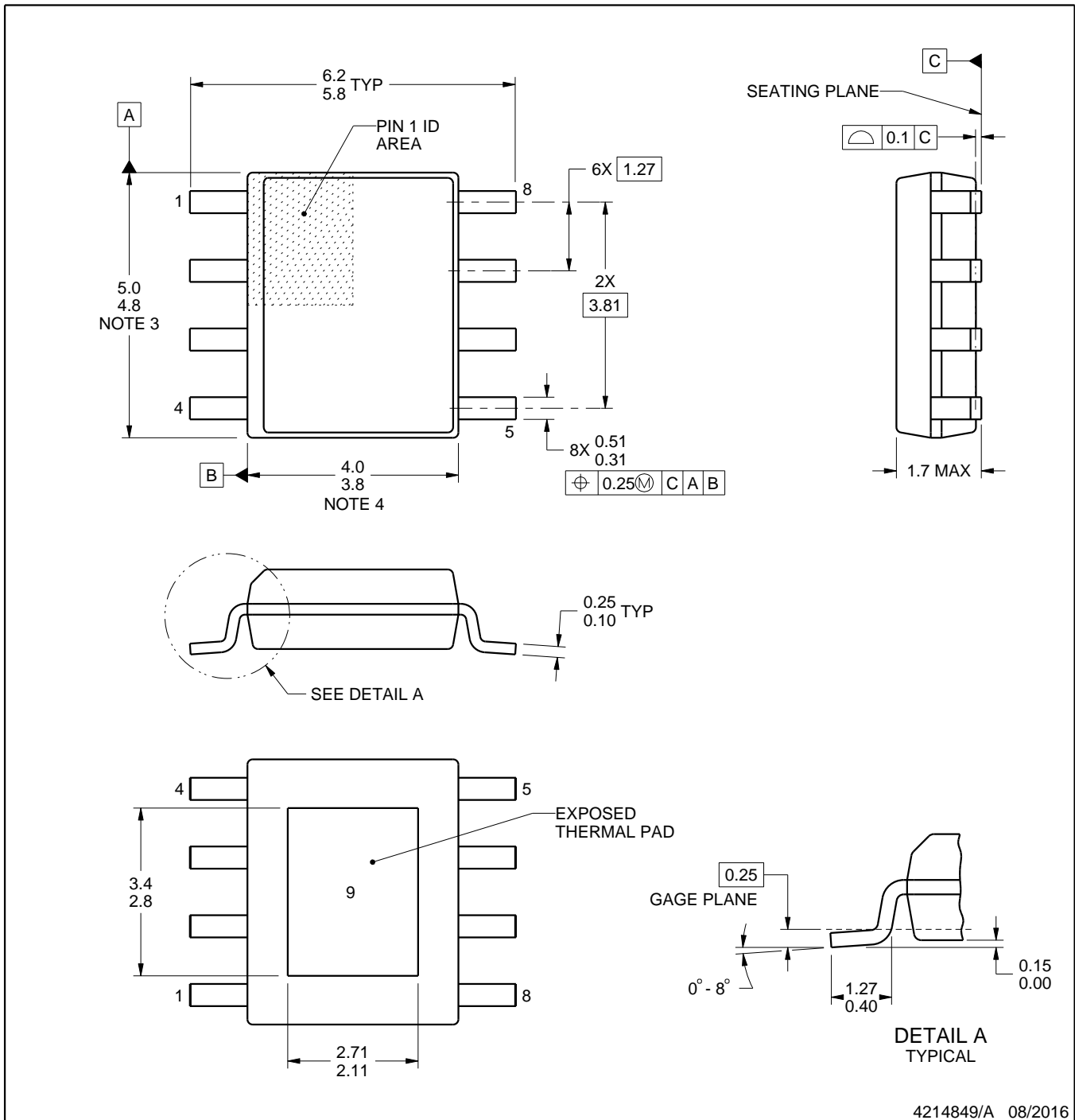

PowerPAD is a trademark of Texas Instruments.

### NOTES:

1. All linear dimensions are in millimeters. Any dimensions in parenthesis are for reference only. Dimensioning and tolerancing per ASME Y14.5M.
2. This drawing is subject to change without notice.
3. This dimension does not include mold flash, protrusions, or gate burrs. Mold flash, protrusions, or gate burrs shall not exceed 0.15 mm per side.
4. This dimension does not include interlead flash. Interlead flash shall not exceed 0.25 mm per side.
5. Reference JEDEC registration MS-012.

# EXAMPLE BOARD LAYOUT

DDA0008B

PowerPAD™ SOIC - 1.7 mm max height

PLASTIC SMALL OUTLINE

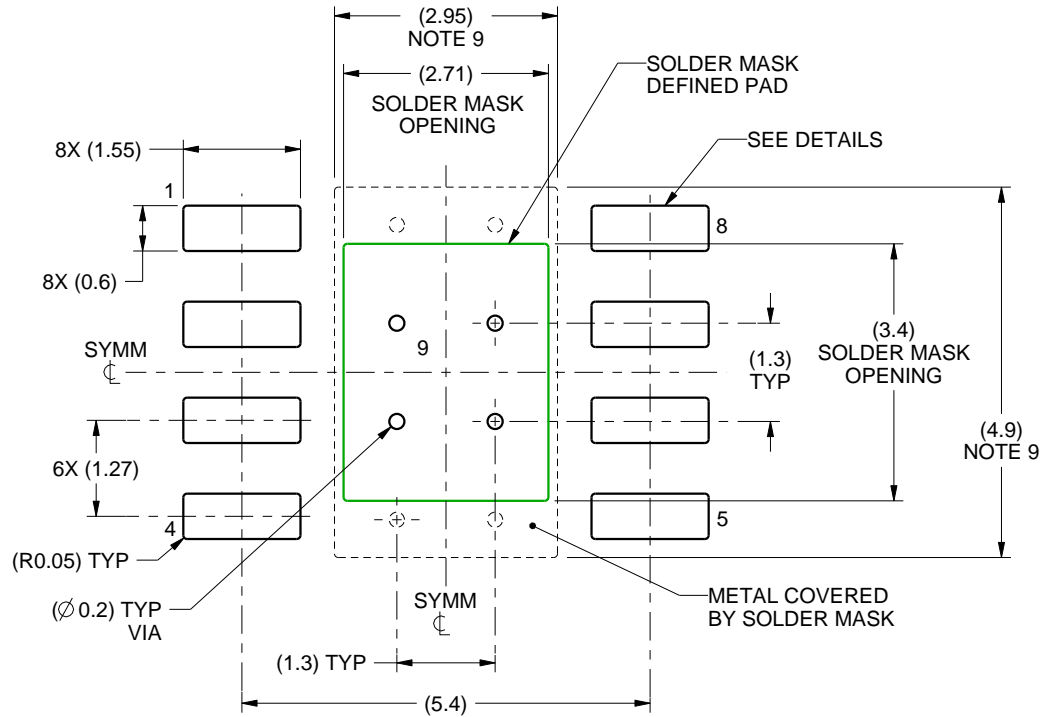

LAND PATTERN EXAMPLE  
SCALE:10X

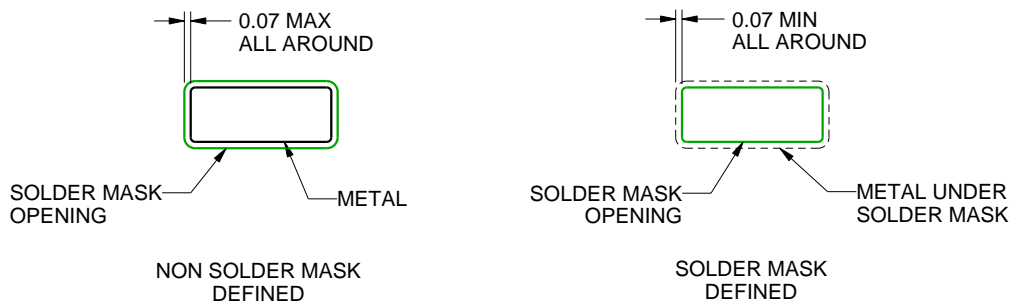

SOLDER MASK DETAILS  
PADS 1-8

4214849/A 08/2016

NOTES: (continued)

6. Publication IPC-7351 may have alternate designs.
7. Solder mask tolerances between and around signal pads can vary based on board fabrication site.
8. This package is designed to be soldered to a thermal pad on the board. For more information, see Texas Instruments literature numbers SLMA002 ([www.ti.com/lit/slma002](http://www.ti.com/lit/slma002)) and SLMA004 ([www.ti.com/lit/slma004](http://www.ti.com/lit/slma004)).
9. Size of metal pad may vary due to creepage requirement.
10. Vias are optional depending on application, refer to device data sheet. If any vias are implemented, refer to their locations shown on this view. It is recommended that vias under paste be filled, plugged or tented.

# EXAMPLE STENCIL DESIGN

DDA0008B

PowerPAD™ SOIC - 1.7 mm max height

PLASTIC SMALL OUTLINE

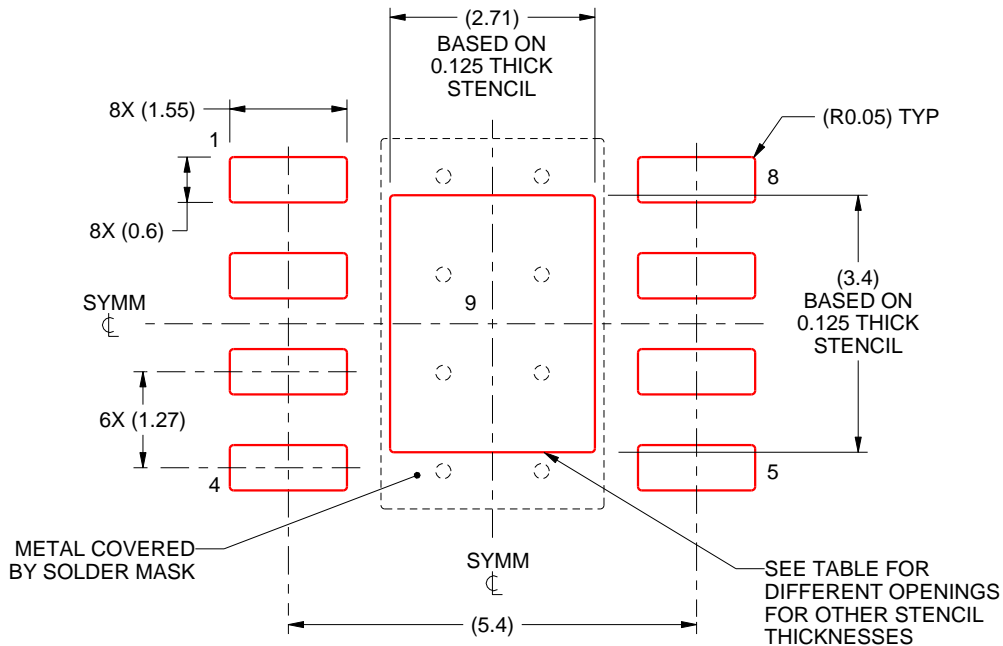

SOLDER PASTE EXAMPLE  
 EXPOSED PAD  
 100% PRINTED SOLDER COVERAGE BY AREA  
 SCALE:10X

STENCIL THICKNESS	SOLDER STENCIL OPENING
0.1	3.03 X 3.80
0.125	2.71 X 3.40 (SHOWN)
0.150	2.47 X 3.10
0.175	2.29 X 2.87

4214849/A 08/2016

NOTES: (continued)

11. Laser cutting apertures with trapezoidal walls and rounded corners may offer better paste release. IPC-7525 may have alternate design recommendations.
12. Board assembly site may have different recommendations for stencil design.

NGT0008A

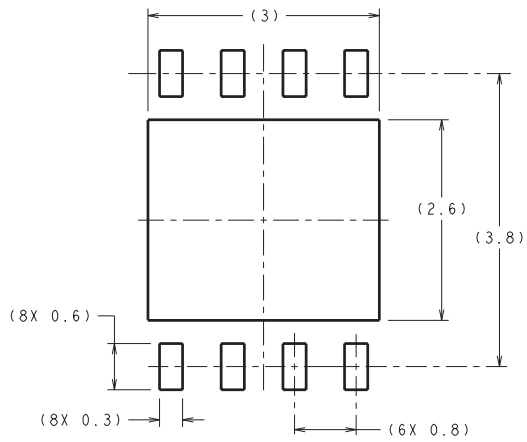

DIMENSIONS ARE IN MILLIMETERS  
DIMENSIONS IN ( ) FOR REFERENCE ONLY

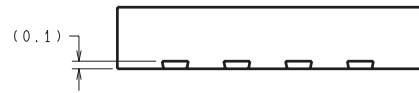

RECOMMENDED LAND PATTERN

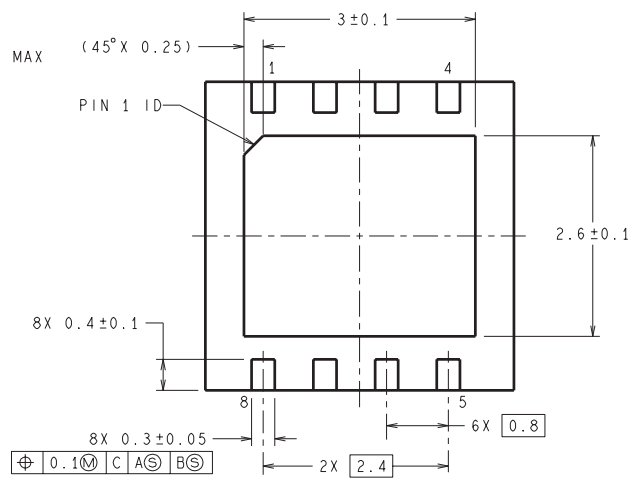
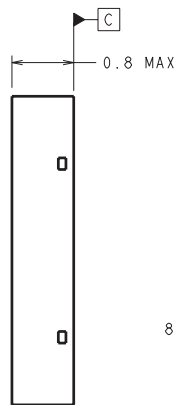
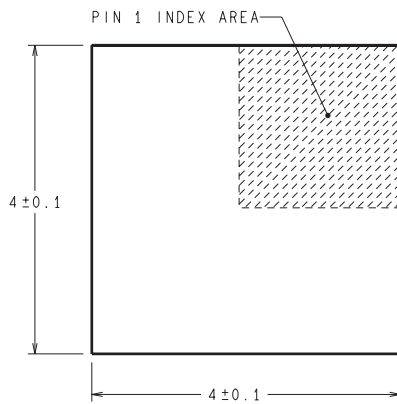

SDC08A (Rev A)





D0008A

# PACKAGE OUTLINE

SOIC - 1.75 mm max height

SMALL OUTLINE INTEGRATED CIRCUIT



4214825/C 02/2019

NOTES:

- Linear dimensions are in inches [millimeters]. Dimensions in parenthesis are for reference only. Controlling dimensions are in inches. Dimensioning and tolerancing per ASME Y14.5M.
- This drawing is subject to change without notice.
- This dimension does not include mold flash, protrusions, or gate burrs. Mold flash, protrusions, or gate burrs shall not exceed .006 [0.15] per side.
- This dimension does not include interlead flash.
- Reference JEDEC registration MS-012, variation AA.

# EXAMPLE BOARD LAYOUT

D0008A

SOIC - 1.75 mm max height

SMALL OUTLINE INTEGRATED CIRCUIT



LAND PATTERN EXAMPLE  
 EXPOSED METAL SHOWN  
 SCALE:8X



SOLDER MASK DETAILS

4214825/C 02/2019

NOTES: (continued)

- 6. Publication IPC-7351 may have alternate designs.
- 7. Solder mask tolerances between and around signal pads can vary based on board fabrication site.

# EXAMPLE STENCIL DESIGN

D0008A

SOIC - 1.75 mm max height

SMALL OUTLINE INTEGRATED CIRCUIT



SOLDER PASTE EXAMPLE  
BASED ON .005 INCH [0.125 MM] THICK STENCIL  
SCALE:8X

4214825/C 02/2019

NOTES: (continued)

8. Laser cutting apertures with trapezoidal walls and rounded corners may offer better paste release. IPC-7525 may have alternate design recommendations.
9. Board assembly site may have different recommendations for stencil design.

DGN0008A

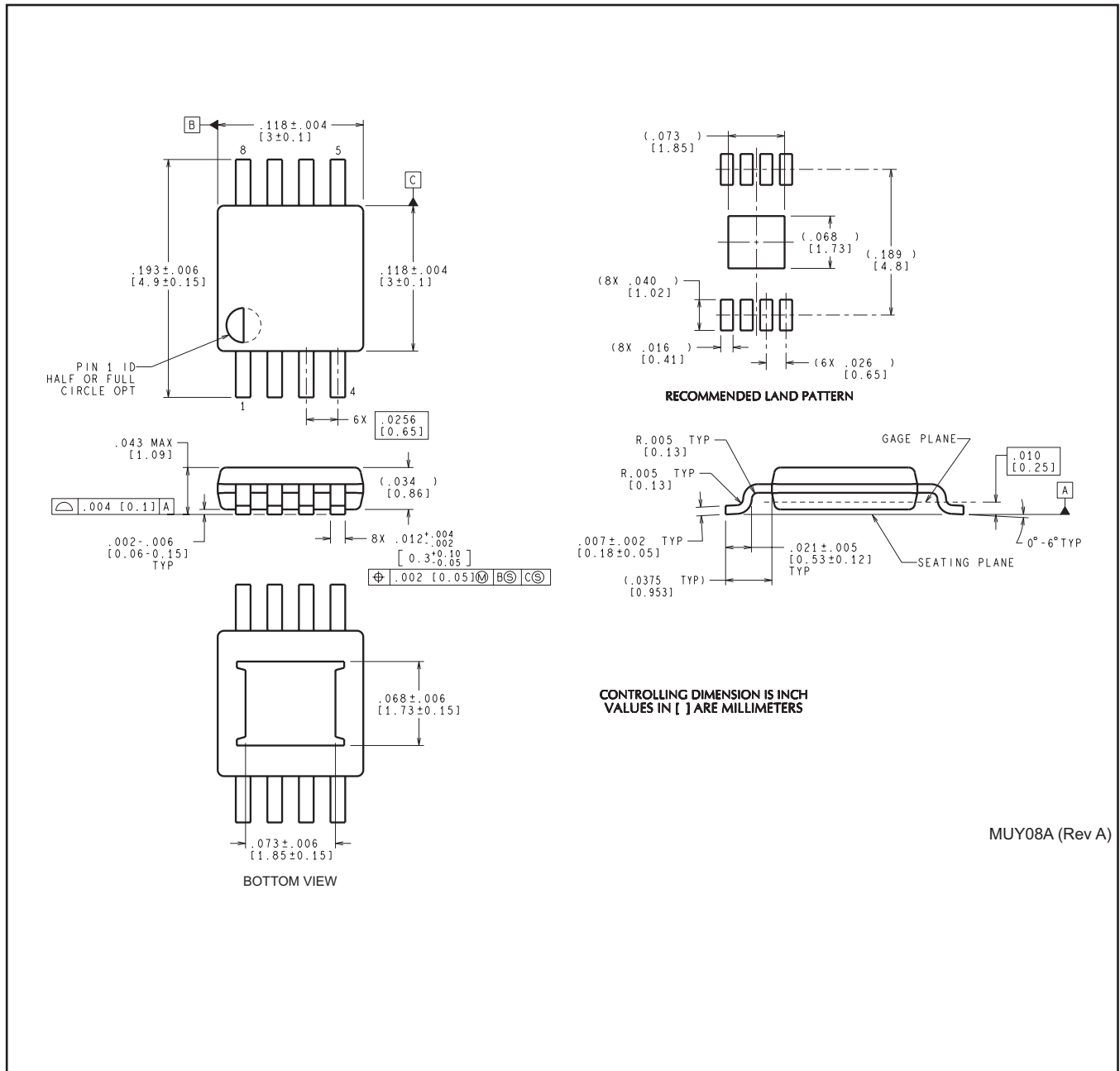

MUY08A (Rev A)

## IMPORTANT NOTICE AND DISCLAIMER

TI PROVIDES TECHNICAL AND RELIABILITY DATA (INCLUDING DATASHEETS), DESIGN RESOURCES (INCLUDING REFERENCE DESIGNS), APPLICATION OR OTHER DESIGN ADVICE, WEB TOOLS, SAFETY INFORMATION, AND OTHER RESOURCES "AS IS" AND WITH ALL FAULTS, AND DISCLAIMS ALL WARRANTIES, EXPRESS AND IMPLIED, INCLUDING WITHOUT LIMITATION ANY IMPLIED WARRANTIES OF MERCHANTABILITY, FITNESS FOR A PARTICULAR PURPOSE OR NON-INFRINGEMENT OF THIRD PARTY INTELLECTUAL PROPERTY RIGHTS.



These resources are intended for skilled developers designing with TI products. You are solely responsible for (1) selecting the appropriate TI products for your application, (2) designing, validating and testing your application, and (3) ensuring your application meets applicable standards, and any other safety, security, or other requirements. These resources are subject to change without notice. TI grants you permission to use these resources only for development of an application that uses the TI products described in the resource. Other reproduction and display of these resources is prohibited. No license is granted to any other TI intellectual property right or to any third party intellectual property right. TI disclaims responsibility for, and you will fully indemnify TI and its representatives against, any claims, damages, costs, losses, and liabilities arising out of your use of these resources.

TI's products are provided subject to TI's Terms of Sale ([www.ti.com/legal/termsofsale.html](http://www.ti.com/legal/termsofsale.html)) or other applicable terms available either on [ti.com](http://ti.com) or provided in conjunction with such TI products. TI's provision of these resources does not expand or otherwise alter TI's applicable warranties or warranty disclaimers for TI products.

Mailing Address: Texas Instruments, Post Office Box 655303, Dallas, Texas 75265  
Copyright © 2019, Texas Instruments Incorporated

## Looking for pricing, stock, or lifecycle information?

Click below to explore more details on WIN SOURCE:

-  [View LM25101ASD/NOPB on WIN SOURCE](#)
-  [Texas Instruments](#) Information

## Optimize Your Supply Chain with WIN SOURCE Solutions

-  Global Sourcing Solution
-  Obsolete Management
-  Cost Control Management
-  Shortage Management
-  Alternative Solution
-  Excess Inventory Management