



# THE DATASHEET OF CNW85



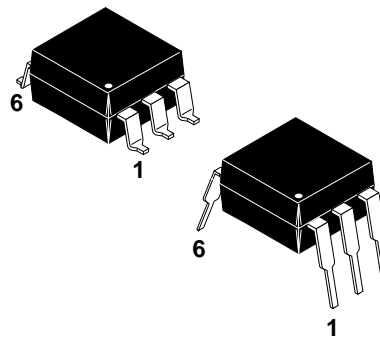
## DESCRIPTION

The CNW82, CNW83, CNW84 and CNW85 optocouplers consist of a GaAs infrared emitting diode which is optically coupled to an NPN phototransistor.

The CNW82 and CNW84 do not have the base pin connected for improved noise immunity.

## FEATURES

- Wide body DIL encapsulation, with a pin distance of 10.16 mm.
- Minimum creepage distance 10 mm.
- High current transfer ratio and Low Saturation Voltage, making the device suitable for use with TTL integrated circuits.
- High degree of AC and DC insulation (5900 V (RMS) and 8340 V (DC)).
- Minimum 2 mm isolation thickness between emitter and detector. (CNW84/85 only).
- An external clearance of 9.6 mm minimum and an external creepage distance of 10 mm minimum.
- Collector-Emitter Breakdown Voltage: 50 V (CNW82/83 only).
- Collector-Emitter Breakdown Voltage: 80 V (CNW84/85 only).
- UL recognized (File # E90700)

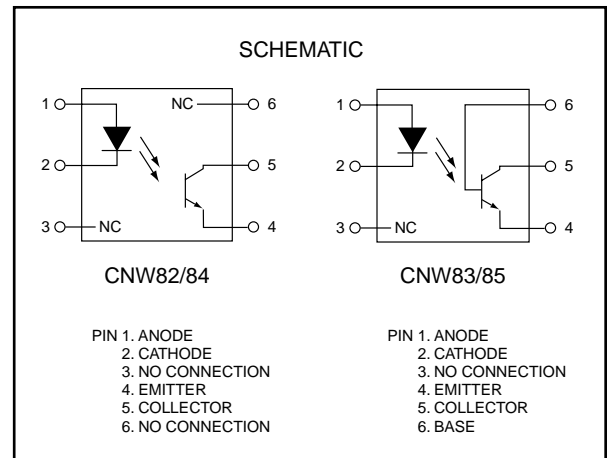


**CNW82**

**CNW83**

**CNW84**

**CNW85**



<b>ABSOLUTE MAXIMUM RATINGS</b>			
Parameter	Symbol	Value	Units
<b>EMITTER</b>			
Forward Current - Continuous	$I_F$	100	mA
Forward Current - Peak (PW = 100µs, 120pps)	$I_F(pk)$	3	A
Reverse Voltage	$V_R$	5	V
Total Power Dissipation @ $T_A = 25^\circ\text{C}$	$P_D$	200	mW
Derate above 25°C		2.0	mW/°C
<b>DETECTOR</b>			
Collector Current-Continuous	$I_C$	100	mA
Emitter-Collector Voltage	$V_{ECO}$	7	V
Collector-Emitter Voltage	$V_{CEO}$	50	V
(CNW82/CNW83)		80	
Collector-Base Voltage	$V_{CBO}$	70	V
(CNW85)		120	
Total Power Dissipation @ $T_A = 25^\circ\text{C}$	$P_D$	200	mW
Derate above 25°C		2.0	mW/°C
<b>TOTAL DEVICE</b>			
Storage Temperature Range	$T_{stg}$	-55 to 150	°C
Ambient Operating Temperature Range	$T_A$	-40 to 100	°C
Lead Soldering Temperature (1/16" from case, 10 sec. duration)	$T_L$	260	°C

**CNW82, CNW83, CNW84, CNW85**

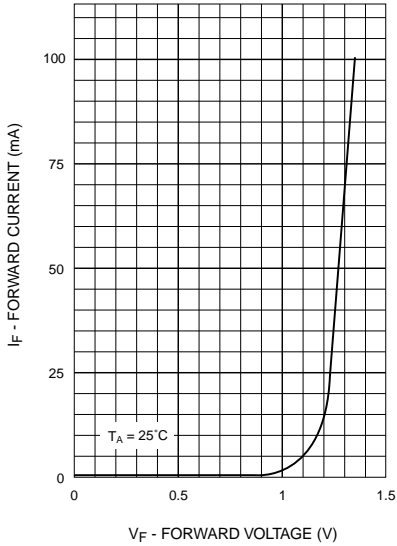
<b>ELECTRICAL CHARACTERISTICS</b> ( $T_A = 25^\circ\text{C}$ Unless otherwise specified)						
Parameter	Test Conditions	Symbol	Min	Typ	Max	Unit
<b>EMITTER</b>						
Input Forward Voltage	( $I_F = 10\text{ mA}$ )	$V_F$	—	1.20	1.50	V
Reverse Leakage Current	( $V_R = 5.0\text{ V}$ )	$I_R$	—	—	10	$\mu\text{A}$
<b>DETECTOR</b>						
Collector-Emitter Breakdown Voltage	( $I_C = 1.0\text{ mA}$ )	$BV_{CEO}$	50	100	—	V
Emitter-Collector Breakdown Voltage	( $I_E = 0.1\text{ mA}$ )	$BV_{ECO}$	7	10	—	V
Collector-Base Breakdown Voltage	( $I_C = 0.1\text{ mA}$ )	$BV_{CBO}$	70	100	—	V
Collector-Emitter Dark Current	( $V_{CE} = 10\text{ V}, I_F = 0$ )	$I_{CEO}$	—	1	50	nA
Collector-Base Cut-off Current	( $V_{CB} = 10\text{ V}, I_F = 0$ )	$I_{CBO}$	—	—	20	nA
<b>COUPLED</b>						
Collector-Emitter Saturation Voltage	( $I_C = 4\text{ mA}, I_F = 10\text{ mA}$ )	$V_{CE(sat)}$	—	0.15	0.4	V
Isolation Voltage	(DC Value) (t = 1.0 min.) <sup>(1)</sup> (RMS Value) (t = 1.0 min.) <sup>(1)</sup>	$V_{ISO}$	8.34	—	—	kV
Isolation Resistance	( $V_{I-O} = 500\text{ V}$ )	$R_{ISO}$	1	10	—	$T\Omega$
Isolation Capacitance	( $V_{I-O} = 0, f = 1.0\text{ MHz}$ )	$C_{ISO}$	—	0.4	1	pF
Current Transfer Ratio	( $I_F = 10\text{ mA}, V_{CE} = 0.4\text{ V}$ ) ( $I_F = 10\text{ mA}, V_{CE} = 5\text{ V}$ )	CTR	0.4	0.8	—	%
Capacitance	( $V_{CB} = 10\text{ V}, f = 1\text{ MHz}$ )	$C_{CB}$	—	4.5	—	pF
Turn-on Time	( $I_C = 2\text{ mA}, V_{CC} = 5\text{ V}, R_L = 100\ \Omega$ ) ( $I_C = 2\text{ mA}, V_{CC} = 5\text{ V}, R_L = 1\text{ k}\Omega$ )	$T_{ON}$	—	3	—	$\mu\text{s}$
Turn-off Time	( $I_C = 2\text{ mA}, V_{CC} = 5\text{ V}, R_L = 100\ \Omega$ ) ( $I_C = 2\text{ mA}, V_{CC} = 5\text{ V}, R_L = 1\text{ k}\Omega$ )	$T_{OFF}$	—	3	—	$\mu\text{s}$

**NOTE:**

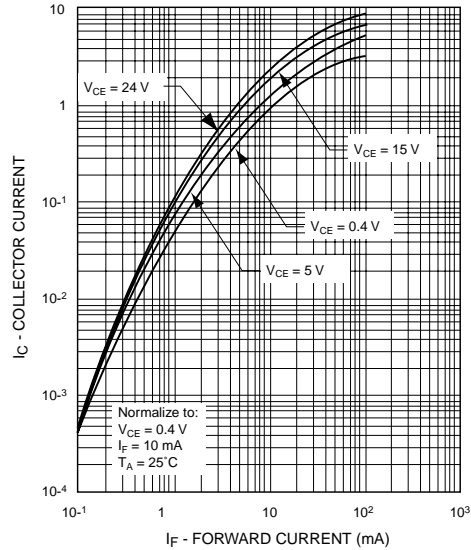
1. Every product is tested with pins 1, 2 and 3 shorted together, and pins 4, 5 and 6 shorted together.

**CNW82, CNW83, CNW84, CNW85**

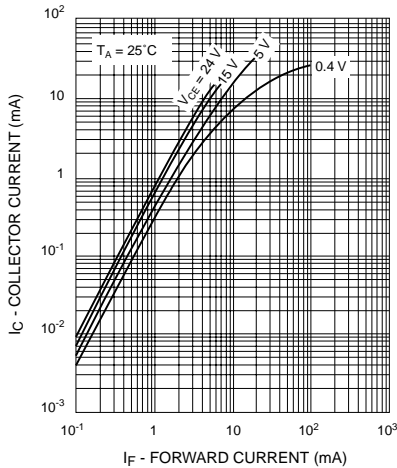
**Fig. 1 Forward Current vs. Forward Voltage**



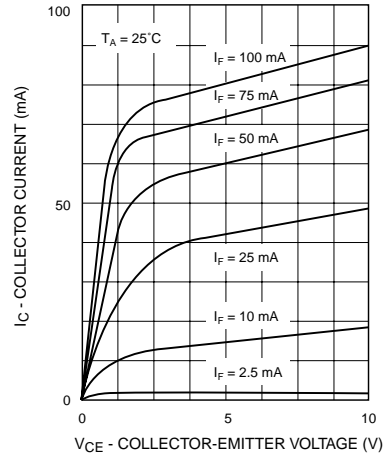
**Fig. 2 Collector Current vs. Forward Current (for CNW84 and CNW85)**



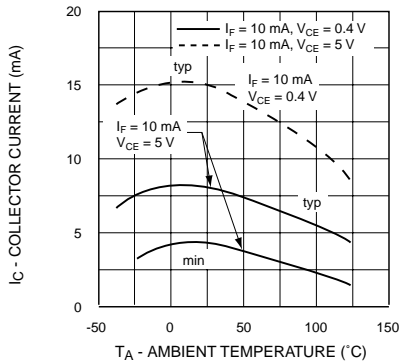
**Fig. 3 Collector Current vs. Forward Current (for CNW82 and CNW83)**



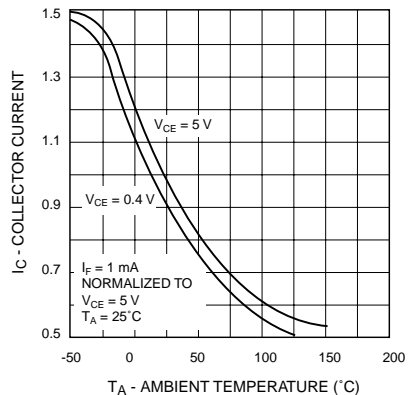
**Fig. 4 Collector Current vs. Collector-Emitter Voltage**



**Fig. 5 Collector Current vs. Ambient Temperature (for CNW82 and CNW83)**

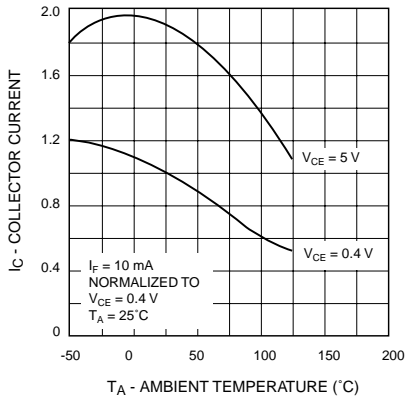


**Fig. 6 Collector Current vs. Ambient Temperature (for CNW84 and CNW85)**

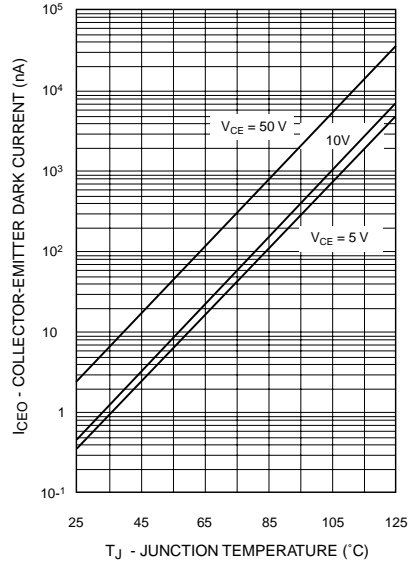


**CNW82, CNW83, CNW84, CNW85**

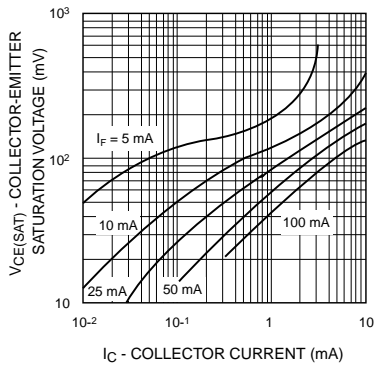
**Fig. 7 Collector Current vs. Ambient Temperature  
(for CNW84 and CNW85)**



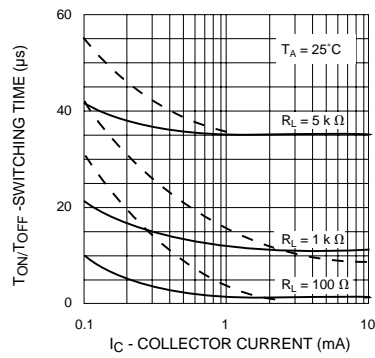
**Fig. 8 Collector-Emitter Dark Current vs. Junction Temperature**



**Fig. 9 Collector-Emitter Saturation Voltage vs. Collector Current**

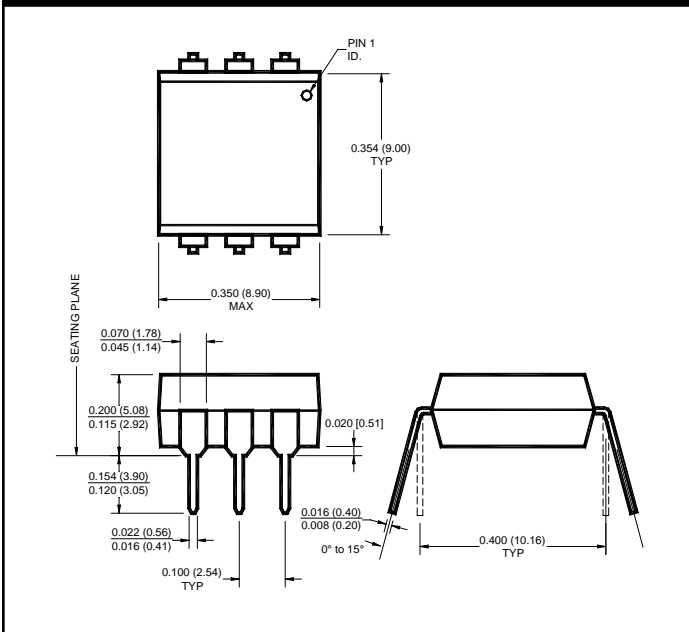


**Fig. 10 Rise and Fall Time vs. Collector Current**

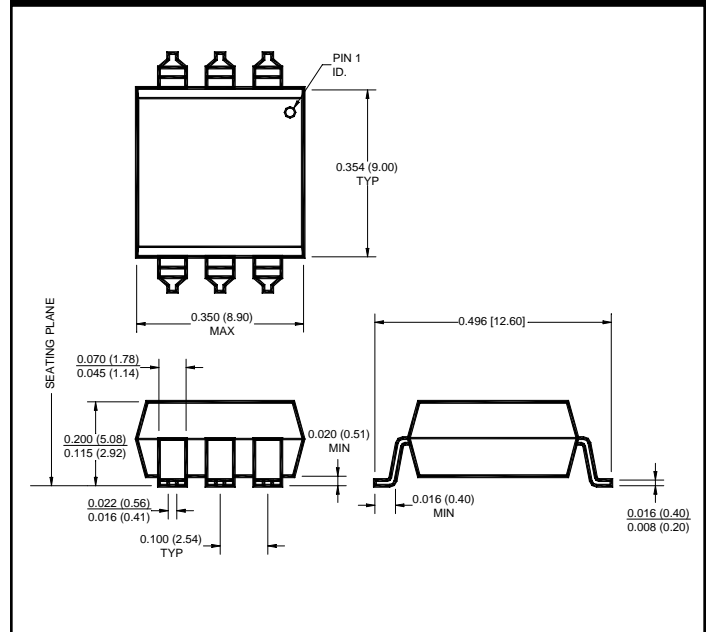


**CNW82, CNW83, CNW84, CNW85**

**Package Dimensions (Through Hole)**



**Package Dimensions (Surface Mount)**



**NOTE**

All dimensions are in inches (millimeters)

## DISCLAIMER

FAIRCHILD SEMICONDUCTOR RESERVES THE RIGHT TO MAKE CHANGES WITHOUT FURTHER NOTICE TO ANY PRODUCTS HEREIN TO IMPROVE RELIABILITY, FUNCTION OR DESIGN. FAIRCHILD DOES NOT ASSUME ANY LIABILITY ARISING OUT OF THE APPLICATION OR USE OF ANY PRODUCT OR CIRCUIT DESCRIBED HEREIN; NEITHER DOES IT CONVEY ANY LICENSE UNDER ITS PATENT RIGHTS, NOR THE RIGHTS OF OTHERS.

## LIFE SUPPORT POLICY

FAIRCHILD'S PRODUCTS ARE NOT AUTHORIZED FOR USE AS CRITICAL COMPONENTS IN LIFE SUPPORT DEVICES OR SYSTEMS WITHOUT THE EXPRESS WRITTEN APPROVAL OF THE PRESIDENT OF FAIRCHILD SEMICONDUCTOR CORPORATION. As used herein:

1. Life support devices or systems are devices or systems which, (a) are intended for surgical implant into the body, or (b) support or sustain life, and (c) whose failure to perform when properly used in accordance with instructions for use provided in the labeling, can be reasonably expected to result in a significant injury of the user.
2. A critical component in any component of a life support device or system whose failure to perform can be reasonably expected to cause the failure of the life support device or system, or to affect its safety or effectiveness.

## Looking for pricing, stock, or lifecycle information?

Click below to explore more details on WIN SOURCE:

- ⊖ [View CNW85 on WIN SOURCE](#)
- ⊖ [ON Semiconductor Information](#)

## Optimize Your Supply Chain with WIN SOURCE Solutions

- ✓ Global Sourcing Solution
- ✓ Obsolete Management
- ✓ Cost Control Management
- ✓ Shortage Management
- ✓ Alternative Solution
- ✓ Excess Inventory Management