



**THE DATASHEET OF
ADG791ABCPZ-500RL7**



FEATURES

- Bandwidth: 325 MHz**
- Low insertion loss and on resistance: 2.6 Ω typical**
- On resistance flatness: 0.3 Ω typical**
- Single 3 V/5 V supply operation**
- 3.3 V analog signal range (5 V supply, 75 Ω load)**
- Low quiescent supply current: 1 nA typical**
- Fast switching times: $t_{ON} = 186$ ns, $t_{OFF} = 177$ ns**
- I²C[®]-compatible interface**
- Compact 24-lead LFCSP**
- ESD protection**
 - 4 kV human body model (HBM)**
 - 200 V machine model (MM)**
 - 1 kV field-induced charged device model (FICDM)**

APPLICATIONS

- S-video RGB/YPbPr video switches**
- HDTVs**
- Projection TVs**
- DVD-R/RW**
- AV receivers**

GENERAL DESCRIPTION

The ADG791A/ADG791G are monolithic CMOS devices comprising four 2:1 multiplexers/demultiplexers controllable via a standard I²C serial interface. The CMOS process provides ultralow power dissipation yet gives high switching speed and low on resistance.

The on-resistance profile is very flat over the full analog input range and wide bandwidth ensures excellent linearity and low distortion. These features, combined with a wide input signal range make the ADG791A/ADG791G the ideal switching solution for a wide range of TV applications including S-video, RGB, and YPbPr video switches.

The switches conduct equally well in both directions when on. In the off condition, signal levels up to the supplies are blocked. The ADG791A/ADG791G switches exhibit break-before-make switching action. The ADG791G has one general-purpose logic output pin controlled by the I²C interface that can also be used to control other non-I²C-compatible devices such as video filters. The integrated I²C interface provides a large degree of flexibility in the system design. It has three configurable I²C address pins

FUNCTIONAL BLOCK DIAGRAM

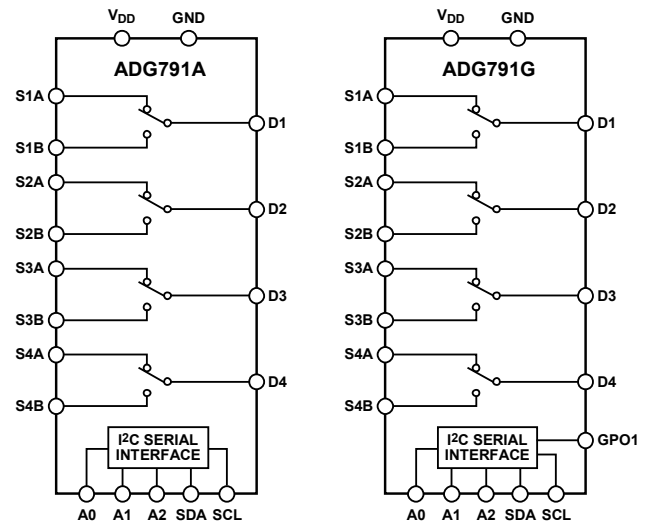

Figure 1.

that allow up to eight devices on the same bus. This allows the user to expand the capability of the device by increasing the size of the switching array.

The ADG791A/ADG791G operate from a single 3 V or 5 V supply voltage and is available in a compact 4 mm \times 4 mm body, 24-lead LFCSP.

PRODUCT HIGHLIGHTS

1. Wide bandwidth: 325 MHz.
2. Ultralow power dissipation.
3. Extended input signal range.
4. Integrated I²C serial interface.
5. Compact 4 mm \times 4 mm, 24-lead, Pb-free LFCSP.
6. ESD protection tested as per ESD association standards:
 - 4 kV HBM (ANSI/ESD STM5.1-2001)
 - 200 V MM (ANSI/ESD STM5.2-1999)
 - 1 kV FICDM (ANSI/ESD STM5.3.1-1999)

Rev. 0

Information furnished by Analog Devices is believed to be accurate and reliable. However, no responsibility is assumed by Analog Devices for its use, nor for any infringements of patents or other rights of third parties that may result from its use. Specifications subject to change without notice. No license is granted by implication or otherwise under any patent or patent rights of Analog Devices. Trademarks and registered trademarks are the property of their respective owners.

TABLE OF CONTENTS

Features	1	Terminology	16
Applications.....	1	Theory of Operation	17
Functional Block Diagram	1	I ² C Serial Interface	17
General Description	1	I ² C Address.....	17
Product Highlights	1	Write Operation.....	17
Revision History	2	LDSW Bit.....	19
Specifications.....	3	Power On/Software Reset.....	19
I ² C Timing Specifications.....	7	Read Operation.....	19
Timing Diagram	8	Evaluation Board	20
Absolute Maximum Ratings.....	9	Using the ADG791G Evaluation Board	20
ESD Caution.....	9	Outline Dimensions	23
Pin Configurations and Function Descriptions	10	Ordering Guide	23
Typical Performance Characteristics	11		
Test Circuits.....	14		

REVISION HISTORY

7/06—Revision 0: Initial Version

SPECIFICATIONS

$V_{DD} = 5\text{ V} \pm 10\%$, $GND = 0\text{ V}$, $T_A = -40^\circ\text{C}$ to $+85^\circ\text{C}$, unless otherwise noted.

Table 1.

Parameter	Conditions	Min	Typ ¹	Max	Unit
ANALOG SWITCH					
Analog Signal Range ²	$V_S = V_{DD}$, $R_L = 1\text{ M}\Omega$	0		4	V
	$V_S = V_{DD}$, $R_L = 75\ \Omega$	0		3.3	V
On Resistance, R_{ON}	$V_D = 0\text{ V}$, $I_{DS} = -10\text{ mA}$, see Figure 22		2.6	3.5	Ω
	$V_D = 0\text{ V}$ to 1 V , $I_{DS} = -10\text{ mA}$, see Figure 22			4	Ω
On-Resistance Matching Between Channels, ΔR_{ON}	$V_D = 0\text{ V}$, $I_{DS} = -10\text{ mA}$		0.15	0.5	Ω
	$V_D = 1\text{ V}$, $I_{DS} = -10\text{ mA}$			0.6	Ω
On-Resistance Flatness, $R_{FLAT(ON)}$	$V_D = 0\text{ V}$ to 1 V , $I_{DS} = -10\text{ mA}$		0.3	0.55	Ω
LEAKAGE CURRENTS					
Source OFF Leakage ($I_{S(OFF)}$)	$V_D = 4\text{ V}/1\text{ V}$, $V_S = 1\text{ V}/4\text{ V}$, see Figure 23		± 0.25		nA
Drain OFF Leakage ($I_{D(OFF)}$)	$V_D = 4\text{ V}/1\text{ V}$, $V_S = 1\text{ V}/4\text{ V}$, see Figure 23		± 0.25		nA
Channel ON Leakage ($I_{D(ON)}$, $I_{S(ON)}$)	$V_D = V_S = 4\text{ V}/1\text{ V}$, see Figure 24		± 0.25		nA
DYNAMIC CHARACTERISTICS³					
t_{ON} , t_{ENABLE}	$C_L = 35\text{ pF}$, $R_L = 50\ \Omega$, $V_S = 2\text{ V}$, see Figure 28		186	250	ns
t_{OFF} , $t_{DISABLE}$	$C_L = 35\text{ pF}$, $R_L = 50\ \Omega$, $V_S = 2\text{ V}$, see Figure 28		177	240	ns
Break-Before-Make Time Delay, t_D	$C_L = 35\text{ pF}$, $R_L = 50\ \Omega$, $V_{S1} = V_{S2} = 2\text{ V}$, see Figure 29	1	3		ns
I ² C to GPO Propagation Delay, t_H , t_L	(ADG791G only)			130	ns
Off Isolation	$f = 10\text{ MHz}$, $R_L = 50\ \Omega$, see Figure 26		-60		dB
Channel-to-Channel Crosstalk	$f = 10\text{ MHz}$, $R_L = 50\ \Omega$, see Figure 27				
Same Multiplexer			-55		dB
Different Multiplexer			-70		dB
-3 dB Bandwidth	$R_L = 50\ \Omega$, see Figure 25		325		MHz
THD + N	$R_L = 100\ \Omega$		0.14		%
Charge Injection	$C_L = 1\text{ nF}$, $V_S = 0\text{ V}$, see Figure 30		5		pC
$C_{S(OFF)}$			10		pF
$C_{D(OFF)}$			13		pF
$C_{D(ON)}$, $C_{S(ON)}$			27		pF
Power Supply Rejection Ratio, PSRR	$f = 20\text{ kHz}$		70		dB
Differential Gain Error	CCIR330 test signal		0.32		%
Differential Phase Error	CCIR330 test signal		0.44		Degrees
LOGIC INPUTS³					
A0, A1, A2		2.0			V
Input High Voltage, V_{INH}				0.8	V
Input Low Voltage, V_{INL}				± 1	V
Input Current, I_{INL} or I_{INH}	$V_{IN} = 0\text{ V}$ to V_{DD}		0.005		μA
Input Capacitance, C_{IN}			3		pF
SCL, SDA		$0.7 \times V_{DD}$		$V_{DD} + 0.3$	V
Input High Voltage, V_{INH}		-0.3		$+0.3 \times V_{DD}$	V
Input Low Voltage, V_{INL}			0.005	± 1	μA
Input Leakage Current, I_{IN}	$V_{IN} = 0\text{ V}$ to V_{DD}		$0.05 \times V_{DD}$		V
Input Hysteresis					V
Input Capacitance, C_{IN}			3		pF

ADG791A/ADG791G

Parameter	Conditions	Min	Typ ¹	Max	Unit
LOGIC OUTPUTS³					
SDA Pin					
Output Low Voltage, V_{OL}	$I_{SINK} = 3\text{ mA}$			0.4	V
	$I_{SINK} = 6\text{ mA}$			0.6	V
Floating-State Leakage Current				± 1	μA
Floating-State Output Capacitance				10	pF
GPO1 Pin and GPO2 Pin					
Output Low Voltage, V_{OL}	$I_{LOAD} = +2\text{ mA}$			0.4	V
Output High Voltage, V_{OH}	$I_{LOAD} = -2\text{ mA}$	2.0			V
POWER REQUIREMENTS					
I_{DD}	Digital inputs = 0V or V_{DD} , I ² C interface inactive		0.001	1	μA
	I ² C interface active, $f_{SCL} = 400\text{ kHz}$			0.2	mA
	I ² C interface active, $f_{SCL} = 3.4\text{ MHz}$			0.7	mA

¹All typical values are at $T_A = 25^\circ\text{C}$, unless otherwise stated.

²Guaranteed by initial characterization, not subject to production test.

³Guaranteed by design, not subject to production test.

$V_{DD} = 3\text{ V} \pm 10\%$, $GND = 0\text{ V}$, $T_A = -40^\circ\text{C}$ to $+85^\circ\text{C}$, unless otherwise noted.

Table 2.

Parameter	Conditions	Min	Typ ¹	Max	Unit
ANALOG SWITCH					
Analog Signal Range ²	$V_S = V_{DD}$, $R_L = 1\text{ M}\Omega$	0		2.2	V
	$V_S = V_{DD}$, $R_L = 75\ \Omega$	0		1.7	V
On Resistance, R_{ON}	$V_D = 0\text{ V}$, $I_{DS} = -10\text{ mA}$, see Figure 22		3	4	Ω
	$V_D = 0\text{ V}$ to 1 V , $I_{DS} = -10\text{ mA}$, see Figure 22			6	Ω
On-Resistance Matching Between Channels, ΔR_{ON}	$V_D = 0\text{ V}$, $I_{DS} = -10\text{ mA}$		0.15	0.6	Ω
	$V_D = 1\text{ V}$, $I_{DS} = -10\text{ mA}$			1.1	Ω
On-Resistance Flatness, $R_{FLAT(ON)}$	$V_D = 0\text{ V}$ to 1 V , $I_{DS} = -10\text{ mA}$		0.8	2.8	Ω
LEAKAGE CURRENTS					
Source Off Leakage ($I_{S(OFF)}$)	$V_D = 2\text{ V}/1\text{ V}$, $V_S = 1\text{ V}/2\text{ V}$, see Figure 23		± 0.25		nA
Drain Off Leakage ($I_{D(OFF)}$)	$V_D = 2\text{ V}/1\text{ V}$, $V_S = 1\text{ V}/2\text{ V}$, see Figure 23		± 0.25		nA
Channel On Leakage ($I_{D(ON)}$, $I_{S(ON)}$)	$V_D = V_S = 2\text{ V}/1\text{ V}$, see Figure 24		± 0.25		nA
DYNAMIC CHARACTERISTICS³					
t_{ON} , t_{ENABLE}	$C_L = 35\text{ pF}$, $R_L = 50\ \Omega$, $V_S = 2\text{ V}$, see Figure 28		198	270	ns
t_{OFF} , $t_{DISABLE}$	$C_L = 35\text{ pF}$, $R_L = 50\ \Omega$, $V_S = 2\text{ V}$, see Figure 28		195	260	ns
Break-Before-Make Time Delay, t_D	$C_L = 35\text{ pF}$, $R_L = 50\ \Omega$, $V_{S1} = V_{S2} = 2\text{ V}$, see Figure 29	1	3		ns
I ² C to GPO Propagation Delay, t_H , t_L (ADG791G only)				121	ns
Off Isolation	$f = 10\text{ MHz}$, $R_L = 50\ \Omega$, see Figure 26		-60		dB
Channel-to-Channel Crosstalk	$f = 10\text{ MHz}$, $R_L = 50\ \Omega$, see Figure 27				
Same Multiplexer			-55		dB
Different Multiplexer			-70		dB
-3 dB Bandwidth	$R_L = 50\ \Omega$, see Figure 25		310		MHz
THD + N	$R_L = 100\ \Omega$		0.14		%
Charge Injection	$C_L = 1\text{ nF}$, $V_S = 0\text{ V}$, see Figure 30		2.5		pC
$C_{S(OFF)}$			10		pF
$C_{D(OFF)}$			13		pF
$C_{D(ON)}$, $C_{S(ON)}$			27		pF
Power Supply Rejection Ratio, PSRR	$f = 20\text{ kHz}$		70		dB
Differential Gain Error	CCIR330 test signal		0.28		%
Differential Phase Error	CCIR330 test signal		0.28		Degrees
LOGIC INPUTS³					
A0, A1, A2		2.0			V
Input High Voltage, V_{INH}				0.8	V
Input Low Voltage, V_{INL}				± 1	μA
Input Current, I_{INL} or I_{INH}	$V_{IN} = 0\text{ V}$ to V_{DD}		0.005		μA
Input Capacitance, C_{IN}			3		pF
SCL, SDA		$0.7 \times V_{DD}$		$V_{DD} + 0.3$	V
Input High Voltage, V_{INH}		-0.3		$+0.3 \times V_{DD}$	V
Input Low Voltage, V_{INL}			0.005	± 1	μA
Input Leakage Current, I_{IN}	$V_{IN} = 0\text{ V}$ to V_{DD}		$0.05 \times V_{DD}$		V
Input Hysteresis					V
Input Capacitance, C_{IN}			3		pF

ADG791A/ADG791G

Parameter	Conditions	Min	Typ ¹	Max	Unit
LOGIC OUTPUTS³					
SDA Pin					
Output Low Voltage, V_{OL}	$I_{SINK} = 3 \text{ mA}$			0.4	V
	$I_{SINK} = 6 \text{ mA}$			0.6	V
Floating-State Leakage Current				± 1	μA
Floating-State Output Capacitance			3		pF
GPO1 Pin and GPO2 Pin					
Output Low Voltage, V_{OL}	$I_{LOAD} = +2 \text{ mA}$			0.4	V
Output High Voltage, V_{OH}	$I_{LOAD} = -2 \text{ mA}$	2.0			V
POWER REQUIREMENTS					
I_{DD}	Digital inputs = 0 V or V_{DD} , I ² C interface inactive		0.001	1	μA
	I ² C interface active, $f_{SCL} = 400 \text{ kHz}$			0.1	mA
	I ² C interface active, $f_{SCL} = 3.4 \text{ MHz}$			0.2	mA

¹All typical values are at $T_A = 25^\circ\text{C}$, unless otherwise stated.

²Guaranteed by initial characterization, not subject to production test.

³Guaranteed by design, not subject to production test.

I²C TIMING SPECIFICATIONS

$V_{DD} = 2.7\text{ V to }5.5\text{ V}$; $GND = 0\text{ V}$; $T_A = -40^\circ\text{C to }+85^\circ\text{C}$, unless otherwise noted. See Figure 2 for timing diagram.

Table 3.

Parameter ¹	Conditions	Min	Max	Unit	Description
f_{SCL}	Standard mode		100	kHz	Serial clock frequency
	Fast mode		400	kHz	
	High speed mode				
	$C_B = 100\text{ pF max}$		3.4	MHz	
	$C_B = 400\text{ pF max}$		1.7	MHz	
t_1	Standard mode	4		μs	t_{HIGH} , SCL high time
	Fast mode	0.6		μs	
	High speed mode				
	$C_B = 100\text{ pF max}$	60		ns	
	$C_B = 400\text{ pF max}$	120		ns	
t_2	Standard mode	4.7		μs	t_{LOW} , SCL low time
	Fast mode	1.3		μs	
	High speed mode				
	$C_B = 100\text{ pF max}$	160		ns	
	$C_B = 400\text{ pF max}$	320		ns	
t_3	Standard mode	250		ns	$t_{SU,DAT}$, data setup time
	Fast mode	100		ns	
	High speed mode	10		ns	
t_4^2	Standard mode	0	3.45	μs	$t_{HD,DAT}$, data hold time
	Fast mode	0	0.9	μs	
	High speed mode				
	$C_B = 100\text{ pF max}$	0	703	ns	
	$C_B = 400\text{ pF max}$	0	150	ns	
t_5	Standard mode	4.7		μs	$t_{SU,STA}$, setup time for a repeated start condition
	Fast mode	0.6		μs	
	High speed mode	160		ns	
t_6	Standard mode	4		μs	$t_{HD,STA}$, hold time (repeated) start condition
	Fast mode	0.6		μs	
	High speed mode	160		ns	
t_7	Standard mode	4.7		μs	t_{BUF} , bus free time between a stop and a start condition
	Fast mode	1.3		μs	
t_8	Standard mode	4		μs	$t_{SU,STO}$, setup time for stop condition
	Fast mode	0.6		μs	
	High speed mode	160		ns	
t_9	Standard mode		1000	ns	t_{RDA} , rise time of SDA signal
	Fast mode	$20 + 0.1 C_B$	300	ns	
	High speed mode				
	$C_B = 100\text{ pF max}$	10	80	ns	
	$C_B = 400\text{ pF max}$	20	160	ns	
t_{10}	Standard mode		300	ns	t_{FDA} , fall time of SDA signal
	Fast mode	$20 + 0.1 C_B$	300	ns	
	High speed mode				
	$C_B = 100\text{ pF max}$	10	80	ns	
	$C_B = 400\text{ pF max}$	20	160	ns	
t_{11}	Standard mode		1000	ns	t_{RCL} , rise time of SCL signal
	Fast mode	$20 + 0.1 C_B$	300	ns	
	High speed mode				
	$C_B = 100\text{ pF max}$	10	40	ns	
	$C_B = 400\text{ pF max}$	20	80	ns	

ADG791A/ADG791G

Parameter ¹	Conditions	Min	Max	Unit	Description
t _{11A}	Standard mode		1000	ns	t _{RCL1} , rise time of SCL signal after a repeated start condition and after an acknowledge bit.
	Fast mode	20 + 0.1 C _B	300	ns	
	High speed mode				
	C _B = 100 pF max C _B = 400 pF max	10 20	80 160	ns ns	
t ₁₂	Standard mode		300	ns	t _{FL1} , fall time of SCL signal
	Fast mode	20 + 0.1 C _B	300	ns	
	High speed mode				
	C _B = 100 pF max C _B = 400 pF max	10 20	40 80	ns ns	
t _{SP}	Fast mode	0	50	ns	Pulse width of suppressed spike
	High speed mode	0	10	ns	

¹ Guaranteed by initial characterization. C_B refers to capacitive load on the bus line, t_r and t_f measured between 0.3 V_{DD} and 0.7 V_{DD}.

² A device must provide a data hold time for SDA to bridge the undefined region of the SCL falling edge.

TIMING DIAGRAM

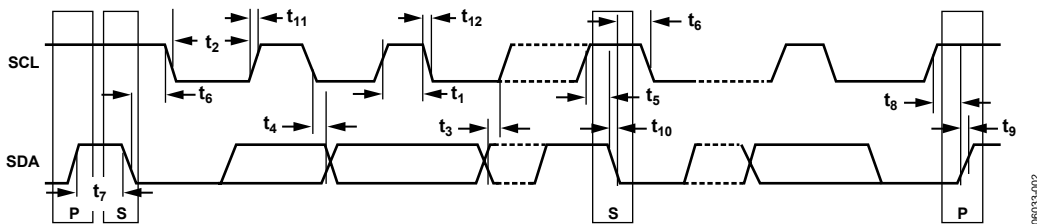

Figure 2. Timing Diagram for 2-Wire Serial Interface

ABSOLUTE MAXIMUM RATINGS

$T_A = 25^\circ\text{C}$, unless otherwise noted.

Table 4.

Parameter	Ratings
V_{DD} to GND	-0.3 V to +6 V
Analog, Digital Inputs	-0.3 V to $V_{DD} + 0.3$ V or 30 mA, whichever occurs first
Continuous Current, S or D	100 mA
Peak Current, S or D	300 mA (pulsed at 1 ms, 10% duty cycle max)
Operating Temperature Range	
Industrial (B Version)	-40°C to +85°C
Storage Temperature Range	-65°C to +150°C
Junction Temperature	150°C
θ_{JA} Thermal Impedance	
24-Lead LFCSP	30°C/W
Lead Temperature, Soldering (10 sec)	300°C
IR Reflow, Peak Temperature (<20 sec)	260°C

Stresses above those listed under Absolute Maximum Ratings may cause permanent damage to the device. This is a stress rating only; functional operation of the device at these or any other conditions above those indicated in the operational section of this specification is not implied. Exposure to absolute maximum rating conditions for extended periods may affect device reliability.

Only one absolute maximum rating may be applied at any one time.

ESD CAUTION

ESD (electrostatic discharge) sensitive device. Electrostatic charges as high as 4000 V readily accumulate on the human body and test equipment and can discharge without detection. Although this product features proprietary ESD protection circuitry, permanent damage may occur on devices subjected to high energy electrostatic discharges. Therefore, proper ESD precautions are recommended to avoid performance degradation or loss of functionality.



ADG791A/ADG791G

PIN CONFIGURATIONS AND FUNCTION DESCRIPTIONS

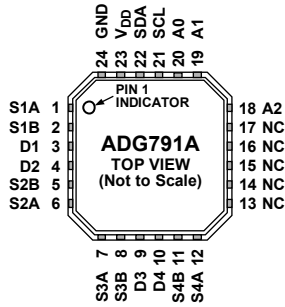

NOTES
 1. NC = NO CONNECT.
 2. THE EXPOSED PAD MUST BE TIED TO GND.

06033-004

Figure 3. ADG791G Pin Configuration

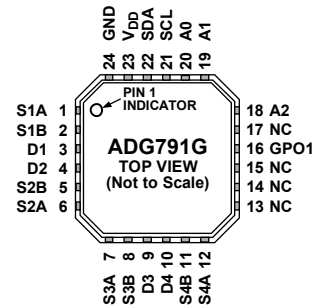

NOTES
 1. NC = NO CONNECT.
 2. THE EXPOSED PAD MUST BE TIED TO GND.

06033-003

Figure 4. ADG791A Pin Configuration

Table 5. ADG791A/ADG791G Pin Function Descriptions

Pin No.	Mnemonic	Description
1	S1A	A-Side Source Terminal for Mux 1. Can be an input or output.
2	S1B	B-Side Source Terminal for Mux 1. Can be an input or output.
3	D1	Drain Terminal for Mux 1. Can be an input or output.
4	D2	Drain Terminal for Mux 2. Can be an input or output.
5	S2B	B-Side Source Terminal for Mux 2. Can be an input or output.
6	S2A	A-Side Source Terminal for Mux 2. Can be an input or output.
7	S3A	A-Side Source Terminal for Mux 3. Can be an input or output.
8	S3B	B-Side Source Terminal for Mux 3. Can be an input or output.
9	D3	Drain Terminal for Mux 3. Can be an input or output.
10	D4	Drain Terminal for Mux 4. Can be an input or output.
11	S4B	B-Side Source Terminal for Mux 4. Can be an input or output.
12	S4A	A-Side Source Terminal for Mux 4. Can be an input or output.
13	NC	Not Internally Connected.
14	NC	Not Internally Connected.
15	NC	Not Internally Connected.
16	NC/GPO1	Not Internally Connected for ADG791A/General-Purpose Logic Output 1 for ADG791G.
17	NC	Not Internally Connected.
18	A2	Logic Input. Sets Bit A2 from the least significant bit of the 7-bit slave address.
19	A1	Logic Input. Sets Bit A1 from the least significant bit of the 7-bit slave address.
20	A0	Logic Input. Sets Bit A0 from the least significant bit of the 7-bit slave address.
21	SCL	Digital Input, Serial Clock Line. Open-drain input that is used in conjunction with SDA to clock data into the device. External pull-up resistor required.
22	SDA	Digital I/O. Bidirectional, open-drain data line. External pull-up resistor required.
23	V _{DD}	Positive Power Supply Input.
24	GND	Ground (0 V) Reference.

TYPICAL PERFORMANCE CHARACTERISTICS

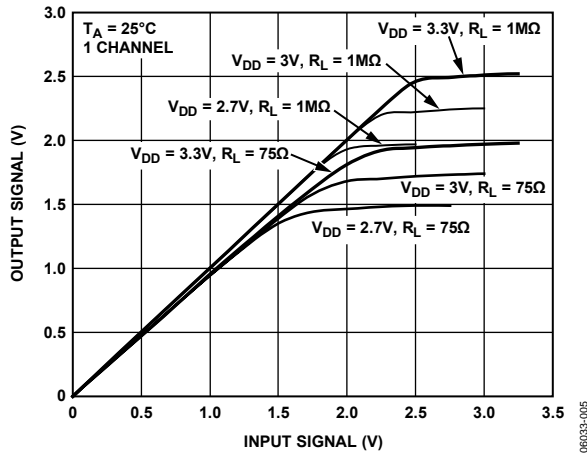

Figure 5. Analog Signal Range, 3 V Supply

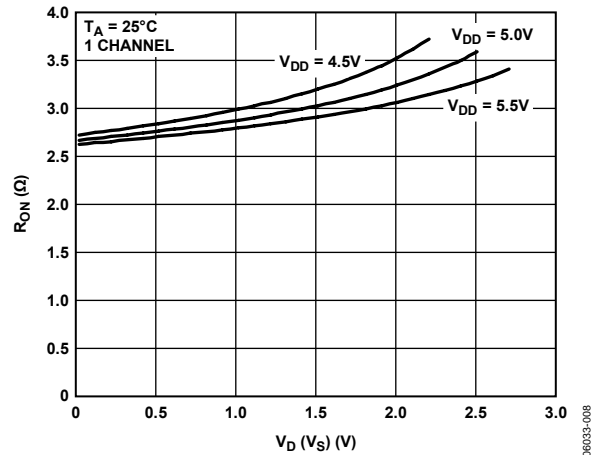

Figure 8. On Resistance vs. V_D (V_S), 5 V Supply

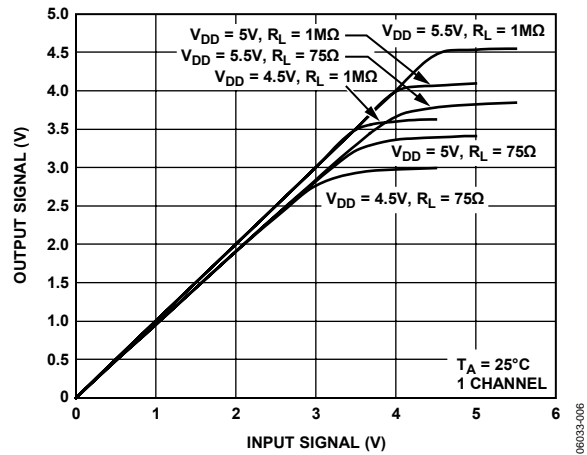

Figure 6. Analog Signal Range, 5 V Supply

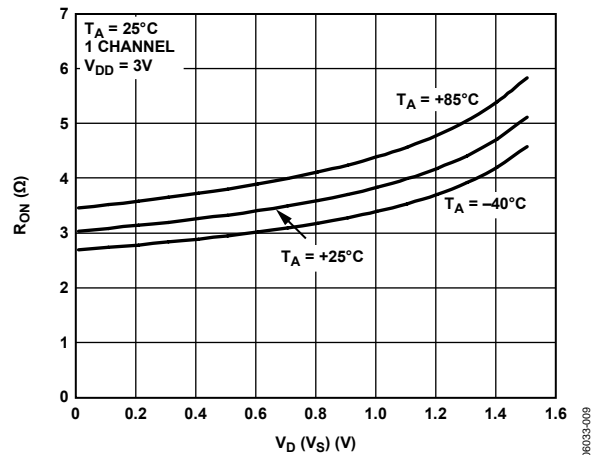

Figure 9. On Resistance vs. V_D (V_S) for Various Temperatures, 3 V Supply

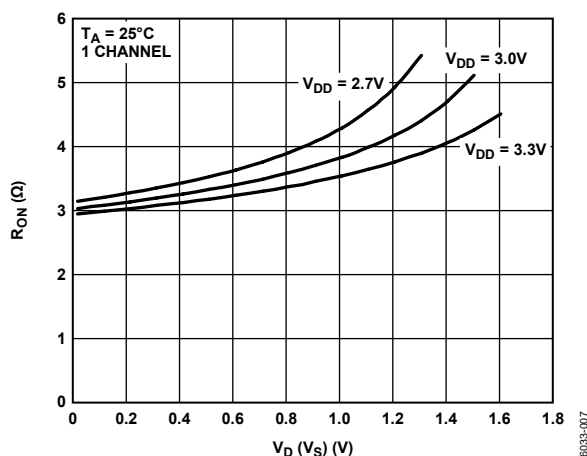

Figure 7. On Resistance vs. V_D (V_S), 3 V Supply

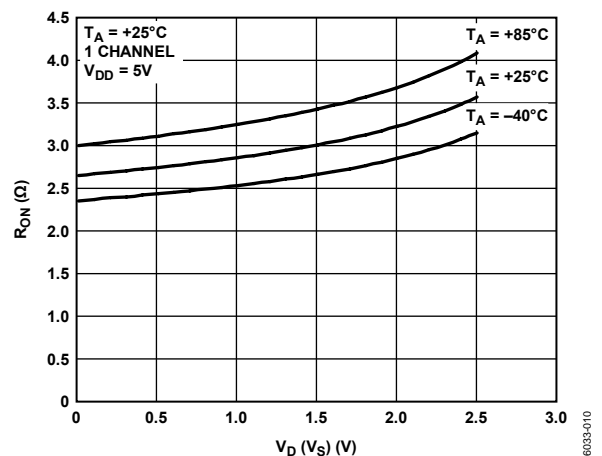

Figure 10. On Resistance vs. V_D (V_S) for Various Temperatures, 5 V Supply

ADG791A/ADG791G

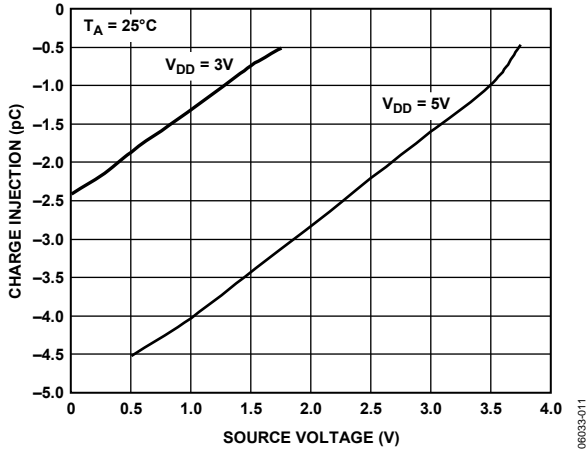

Figure 11. Charge Injection vs. Source Voltage

06033-011

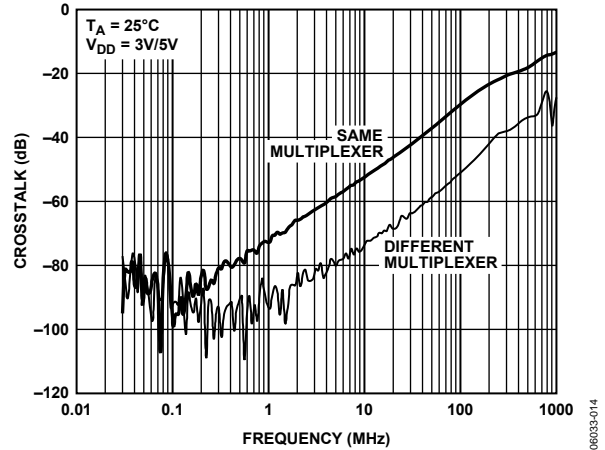

Figure 14. Crosstalk vs. Frequency

06033-014

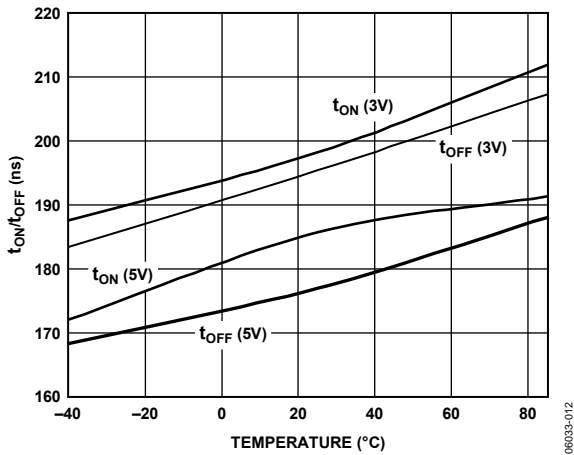

Figure 12. t_{ON}/t_{OFF} vs. Temperature

06033-012

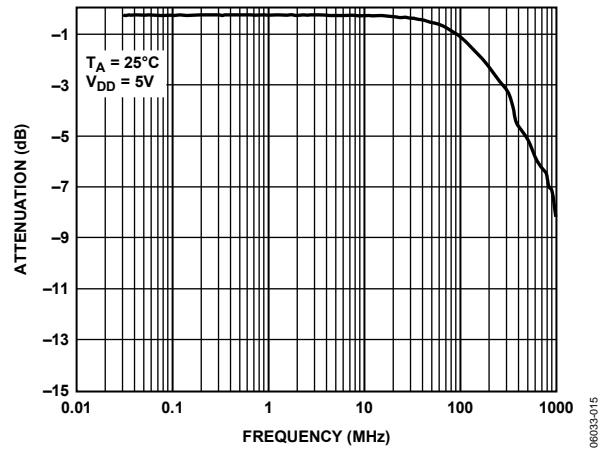

Figure 15. Bandwidth

06033-015

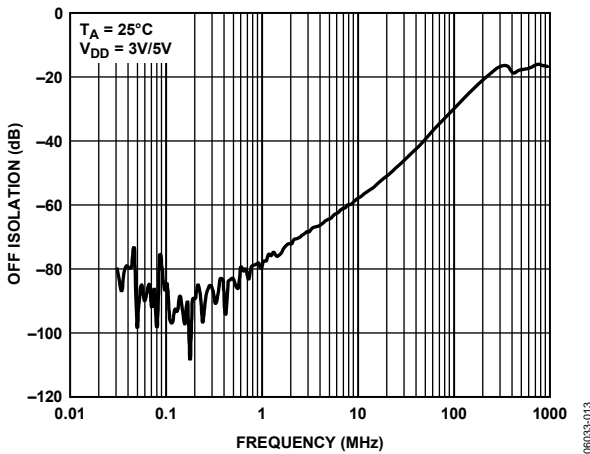

Figure 13. Off Isolation vs. Frequency

06033-013

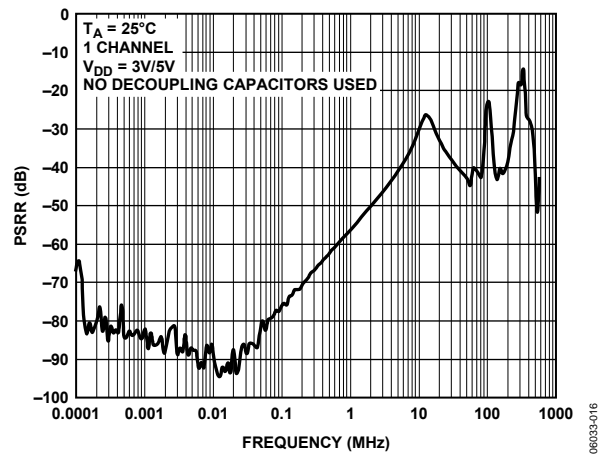

Figure 16. PSRR vs. Frequency

06033-016

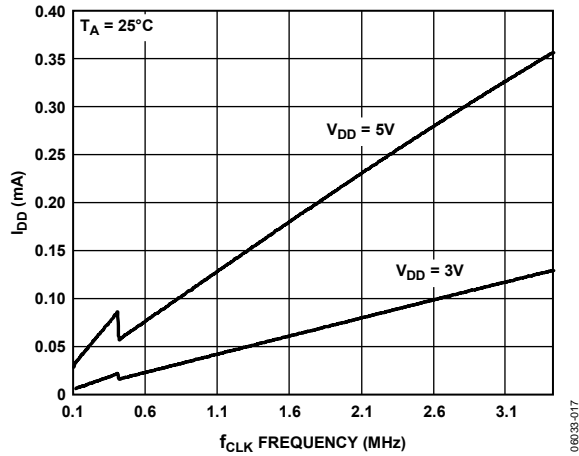

Figure 17. I_{DD} vs. f_{CLK} Frequency

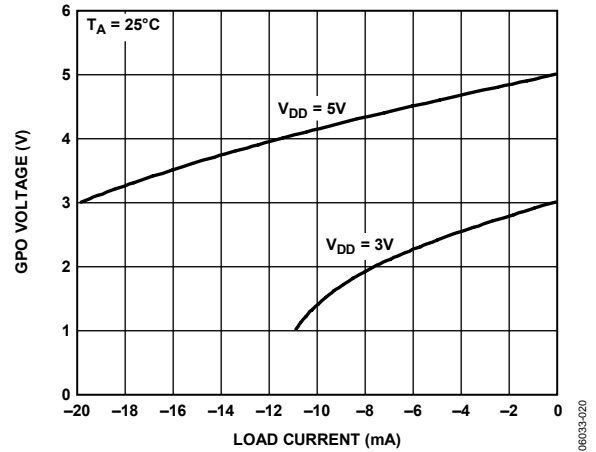

Figure 20. GPO V_{OH} vs. Load Current

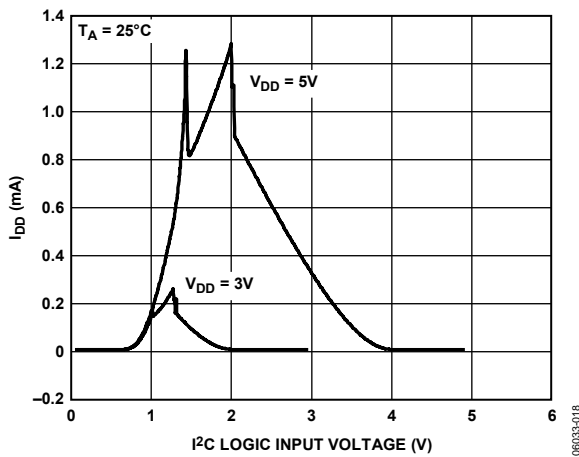

Figure 18. I_{DD} vs. I^2C Logic Input Voltage (SDA, SCL)

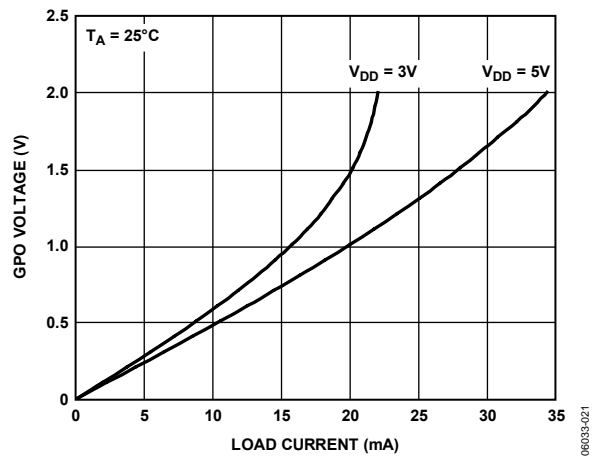

Figure 21. GPO V_{OL} vs. Load Current

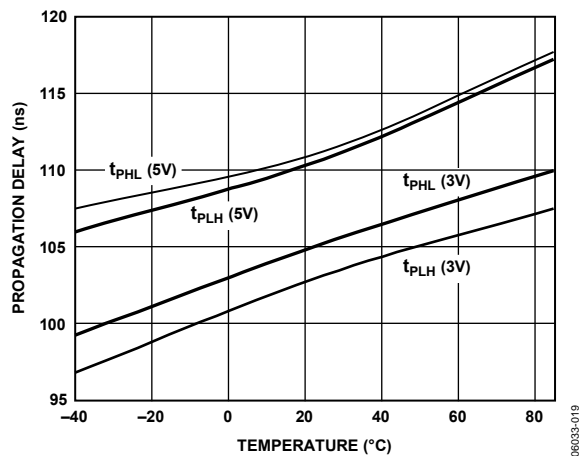

Figure 19. I^2C to GPO Propagation Delay vs. Temperature (ADG791G Only)

TEST CIRCUITS

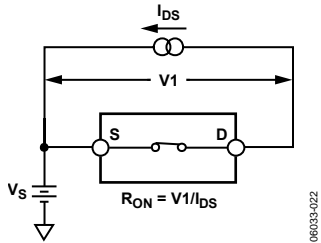

Figure 22. On Resistance

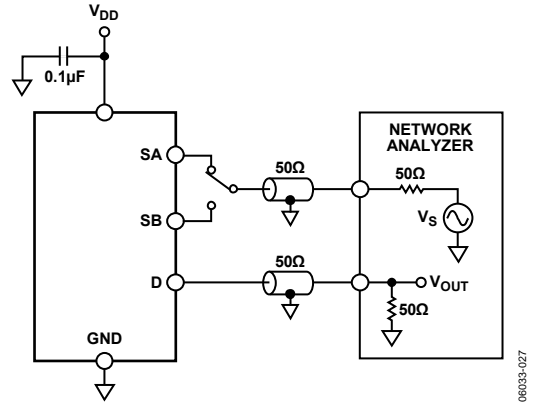

Figure 25. Bandwidth

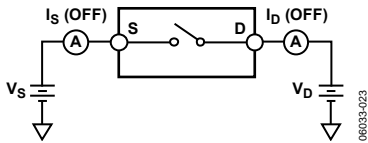

Figure 23. Off Leakage

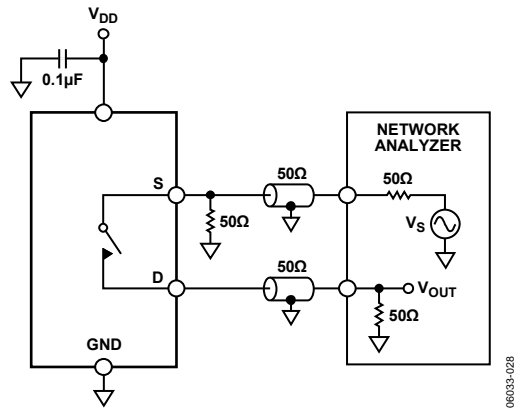

Figure 26. Off Isolation

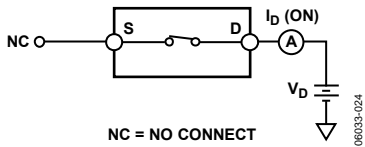

Figure 24. On Leakage

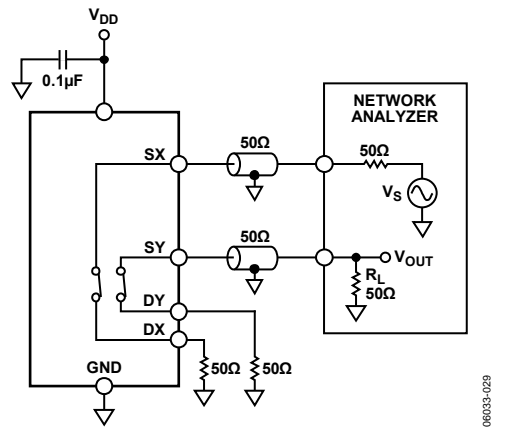

Figure 27. Channel-to-Channel Crosstalk

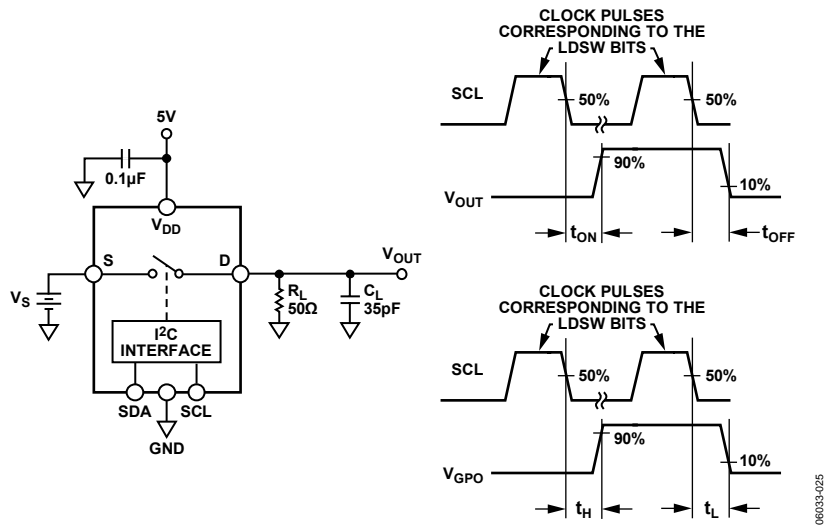

Figure 28. Switching Time

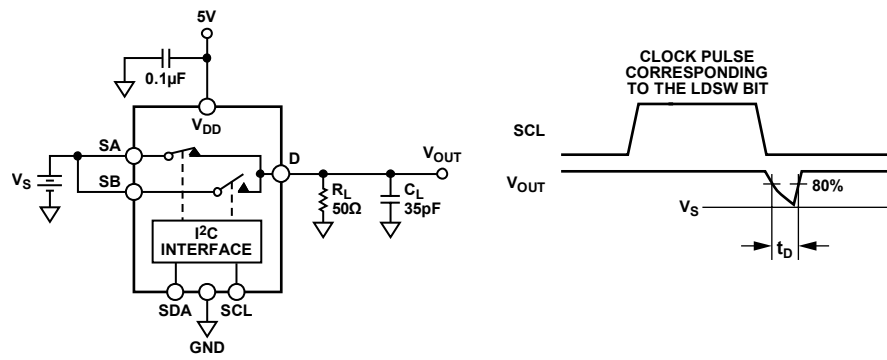

Figure 29. Break-Before-Make Time Delay

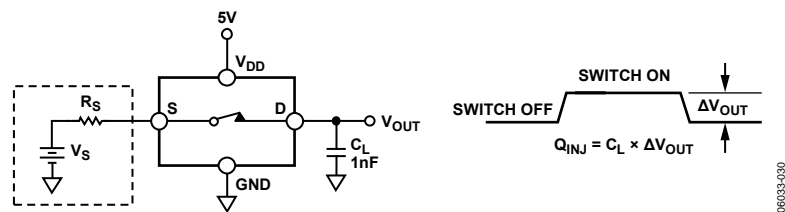

Figure 30. Charge Injection

TERMINOLOGY

On Resistance (R_{ON})

The series on-channel resistance measured between the S and D pins.

On Resistance Match (ΔR_{ON})

The channel-to-channel matching of on resistance when channels are operated under identical conditions.

On Resistance Flatness ($R_{FLAT(ON)}$)

The variation of on resistance over the specified range produced by the specified analog input voltage change with a constant load current.

Channel Off Leakage (I_{OFF})

The sum of leakage currents into or out of an off channel input.

Channel On Leakage (I_{ON})

The current loss/gain through an on-channel resistance, creating a voltage offset across the device.

Input Leakage Current (I_{IN} , I_{INL} , I_{INH})

The current flowing into a digital input when a specified low level or high level voltage is applied to that input.

Input/Output Off Capacitance (C_{OFF})

The capacitance between an analog input and ground when the switch channel is off.

Input/Output On Capacitance (C_{ON})

The capacitance between the inputs or outputs and ground when the switch channel is on.

Digital Input Capacitance (C_{IN})

The capacitance between a digital input and ground.

Output On Switching Time (t_{ON})

The time required for the switch channel to close. The time is measured from 50% of the falling edge of the LDSW bit to the time the output reaches 90% of the final value.

Output Off Switching Time (t_{OFF})

The time required for the switch to open. The time is measured from 50% of the falling edge of the LDSW bit to the time the output reaches 10% of the final value.

I²C to GPO Propagation Delay (t_H , t_L)

The time required for the logic value at the GPO pin to settle after loading a GPO command. The time is measured from 50% of the falling edge of the LDSW bit to the time the output reaches 90% of the final value for high and 10% for low.

Total Harmonic Distortion + Noise (THD + N)

The ratio of the harmonic amplitudes plus noise of a signal to the fundamental.

-3 dB Bandwidth

The frequency at which the output is attenuated by 3 dB.

Off Isolation

The measure of unwanted signal coupling through an off switch.

Crosstalk

The measure of unwanted signal that is coupled through from one channel to another as a result of parasitic capacitance.

Charge Injection

The measure of the glitch impulse transferred from the digital input to the analog output during on/off switching.

Differential Gain Error

The measure of how much color saturation shift occurs when the luminance level changes. Both attenuation and amplification can occur; therefore, the largest amplitude change between any two levels is specified and expressed in %.

Differential Phase Error

The measure of how much hue shift occurs when the luminance level changes. It can be a negative or positive value and is expressed in degrees of subcarrier phase.

Input High Voltage (V_{INH})

The minimum input voltage for Logic 1.

Input Low Voltage (V_{INL})

The maximum input voltage for Logic 0.

Output High Voltage (V_{OH})

The minimum output voltage for Logic 1.

Output Low Voltage (V_{OL})

The maximum output voltage for Logic 0.

I_{DD}

Positive supply current.

THEORY OF OPERATION

The ADG791A/ADG791G are monolithic CMOS devices comprising four 2:1 multiplexers controllable via a standard I²C serial interface. The CMOS process provides ultralow power dissipation, yet offers high switching speed and low on resistance.

The on resistance profile is very flat over the full analog input range, and wide bandwidth ensures excellent linearity and low distortion. These features, combined with a wide input signal range, make the ADG791A/ADG791G an ideal switching solution for a wide range of TV applications.

The switches conduct equally well in both directions when on. In the off condition, signal levels up to the supplies are blocked. The integrated serial I²C interface controls the operation of the switches (ADG791A/ADG791G) and general-purpose logic pins (ADG791G only).

The ADG791A/ADG791G have many attractive features, such as the ability to individually control each multiplexer, the option of reading back the status of any switch. The ADG791G has one general-purpose logic output pin controllable through the I²C interface. The following sections describe these features in detail.

I²C SERIAL INTERFACE

The ADG791A/ADG791G are controlled via an I²C-compatible serial bus interface (refer to the *I²C-Bus Specification* available from Philips Semiconductor) that allows the part to operate as a slave device (no clock is generated by the ADG791A/ADG791G). The communication protocol between the I²C master and the device operates as follows:

1. The master initiates data transfer by establishing a start condition (defined as a high-to-low transition on the SDA line while SCL is high). This indicates that an address/data stream follows. All slave devices connected to the bus respond to the start condition and shift in the next eight bits, consisting of a 7-bit address (MSB first) plus an R/W bit. This bit determines the direction of the data flow during the communication between the master and the addressed slave device.
2. The slave device whose address corresponds to the transmitted address responds by pulling the SDA line low during the ninth clock pulse (this is known as the acknowledge bit).

At this stage, all other devices on the bus remain idle while the selected device waits for data to be written to, or read from, its serial register. If the R/W bit is set high, the master reads from the slave device. However, if the R/W bit is set low, the master writes to the slave device.

3. Data transmits over the serial bus in sequences of nine clock pulses (eight data bits followed by an acknowledge bit). The transitions on the SDA line must occur during the low period of the clock signal, SCL, and remain stable during the high period of SCL. Otherwise, a low-to-high transition when the clock signal is high can be interpreted as a stop event that ends the communication between the master and the addressed slave device.
4. After transferring all data bytes, the master establishes a stop condition, defined as a low-to-high transition on the SDA line while SCL is high. In write mode, the master pulls the SDA line high during the 10th clock pulse to establish a stop condition. In read mode, the master issues a no acknowledge for the ninth clock pulse (the SDA line remains high). The master then brings the SDA line low before the 10th clock pulse, and then high during the 10th clock pulse to establish a stop condition.

I²C ADDRESS

The ADG791A/ADG791G has a 7-bit I²C address. The four most significant bits are internally hardwired while the last three bits (A0, A1, and A2) are user-adjustable. This allows the user to connect up to eight ADG791As/ADG791Gs to the same bus. The I²C bit map shows the configuration of the address.

7-Bit I²C Address Configuration

MSB				LSB		
1	0	1	0	A2	A1	A0

WRITE OPERATION

When writing to the ADG791A/ADG791G, the user must begin with an address byte and R/W bit, after which time the switch acknowledges that it is prepared to receive data by pulling SDA low. Data is loaded into the device as a 16-bit word under the control of a serial clock input, SCL. Figure 31 illustrates the entire write sequence for the ADG791A/ADG791G. The first data byte (AX7 to AX0) controls the status of the switches while the LDSW and RESETB bits from the second byte control the operation mode of the device.

Table 6 shows a list of all commands supported by the ADG791A/ADG791G with the corresponding byte that needs to be loaded during a write operation.

To achieve the desired configuration, one or more commands can be loaded into the device. Any combination of the commands listed in Table 6 can be used with these restrictions:

- Only one switch from a given multiplexer can be ON at any given time
- When a sequence of successive commands affect the same element (that is, the switch or GPO pin), only the last command is executed.

ADG791A/ADG791G

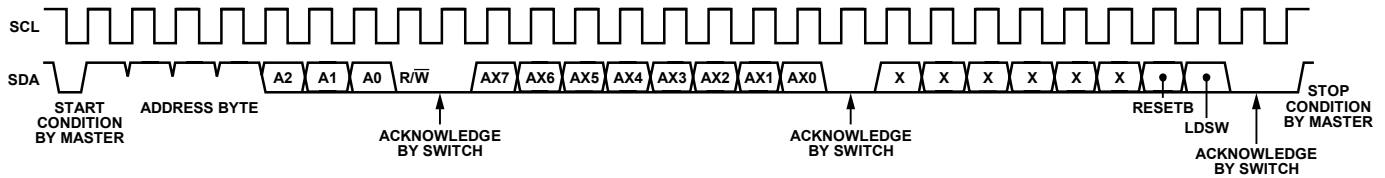

Figure 31. Write Operation

Table 6. ADG791A/ADG791G Command List

AX7	AX6	AX5	AX4	AX3	AX2	AX1	AX0	Addressed Switch
0	0	0	0	0	0	0	0	S1A/D1, S2A/D2, S3A/D3, S4A/D4 off
1	0	0	0	0	0	0	0	S1A/D1, S2A/D2, S3A/D3, S4A/D4 on
0	0	0	0	0	0	0	1	S1B/D1, S2B/D2, S3B/D3, S4B/D4 off
1	0	0	0	0	0	0	1	S1B/D1, S2B/D2, S3B/D3, S4B/D4 on
0	0	0	0	0	0	1	0	S1A/D1 off
1	0	0	0	0	0	1	0	S1A/D1 on
0	0	0	0	0	0	1	1	S1B/D1 off
1	0	0	0	0	0	1	1	S1B/D1 on
0	0	0	0	0	1	0	0	S2A/D2 off
1	0	0	0	0	1	0	0	S2A/D2 on
0	0	0	0	0	1	0	1	S2B/D2 off
1	0	0	0	0	1	0	1	S2B/D2 on
0	0	0	0	0	1	1	0	S3A/D3 off
1	0	0	0	0	1	1	0	S3A/D3 on
0	0	0	0	0	1	1	1	S3B/D3 off
1	0	0	0	0	1	1	1	S3B/D3 on
0	0	0	0	1	0	0	0	S4A/D4 off
1	0	0	0	1	0	0	0	S4A/D4 on
0	0	0	0	1	0	0	1	S4B/D4 off
1	0	0	0	1	0	0	1	S4B/D4 on
X ¹	0	0	0	1	0	1	0	Reserved
X ¹	0	0	0	1	0	1	1	Reserved
X ¹	0	0	0	1	1	0	0	Reserved
X ¹	0	0	0	1	1	0	1	Reserved
X ¹	0	0	0	1	1	1	0	Mux 1 disabled (all switches connected to D1 are off)
X ¹	0	0	0	1	1	1	1	Mux 2 disabled (all switches connected to D2 are off)
X ¹	0	0	1	0	0	0	0	Mux 3 disabled (all switches connected to D3 are off)
X ¹	0	0	1	0	0	0	1	Mux 4 disabled (all switches connected to D4 are off)
X ¹	0	0	1	0	0	1	0	Reserved
X ¹	0	0	1	0	0	1	1	Reserved
1	0	0	1	0	1	0	0	GPO1 high for ADG791G/reserved for ADG791A
0	0	0	1	0	1	0	0	GPO1 low for ADG791G/reserved for ADG791A
0	0	0	1	1	1	1	1	All muxes disabled
1	0	0	1	1	1	1	1	Reserved

¹ X = Logic state does not matter.

LDSW BIT

The LDSW bit allows the user to control the way the device executes the commands loaded during the write operations. The ADG791A/ADG791G executes all the commands loaded between two successive write operations that have set the LDSW bit high.

Setting the LDSW high for every write cycle ensures that the device executes the command right after the LDSW bit was loaded into the device. This setting can be used when the desired configuration can be achieved by sending a single command or when the switches and/or GPO pin are not required to be updated at the same time. When the desired configuration requires multiple commands with simultaneous update, the LDSW bit should be set low while loading the commands except the last one when the LDSW bit should be set high. Once the last command with LDSW = high is loaded, the device executes all commands received since the last update simultaneously.

POWER ON/SOFTWARE RESET

The ADG791A/ADG791G has a software reset function implemented by the RESETB bit from the second data byte written to the device. For normal operation of the multiplexers and GPO pin, this bit should be set high. When RESETB = low or after power-up, the switches from all multiplexers are turned off (open) and the GPO pin is set low.

READ OPERATION

When reading data back from the ADG791A/ADG791G, the user must begin with an address byte and $\overline{R/\overline{W}}$ bit. The switch then acknowledges that it is prepared to transmit data by pulling SDA low. Following this acknowledgement, the ADG791A/ADG791G transmits two bytes on the next clock edges. These bytes contain the status of the switches, and each byte is followed by an acknowledge bit. A logic high bit represents a switch in the on (close) state while a low represents a switch in the off (open) state. For the GPO pin (ADG791G only), the bit represents the logic value of the pin. Figure 32 illustrates the entire read sequence.

The bit maps accompanying Figure 32 show the relationship between the elements of the ADG791A and ADG791G (that is, the switches and GPO pins) and the bits that represent their status after a completed read operation.

ADG791A Bit Map

RB15	RB14	RB13	RB12	RB11	RB10	RB9	RB8	RB7	RB6	RB5	RB4	RB3	RB2	RB1	RB0
S1A/D1	S1B/D1	S2A/D2	S2B/D2	S3A/D3	S3B/D3	S4A/D4	S4B/D4	-	-	-	-	-	-	-	-

ADG791G Bit Map

RB15	RB14	RB13	RB12	RB11	RB10	RB9	RB8	RB7	RB6	RB5	RB4	RB3	RB2	RB1	RB0
S1A/D1	S1B/D1	S2A/D2	S2B/D2	S3A/D3	S3B/D3	S4A/D4	S4B/D4	-	-	-	-	GPO1	-	-	-

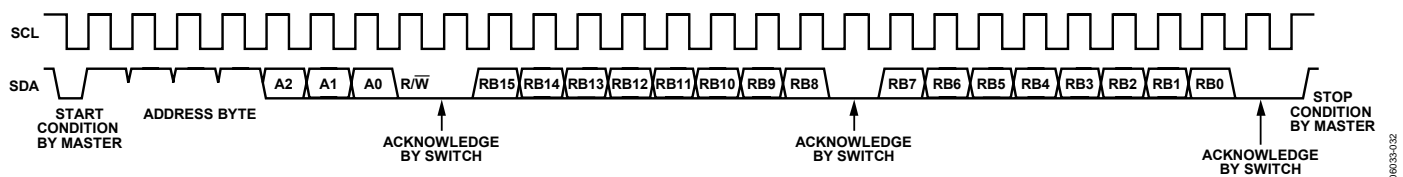

Figure 32. ADG791A/ADG791G Read Operation

EVALUATION BOARD

The ADG791G evaluation kit allows designers to evaluate the high performance of the device with a minimum of effort.

The evaluation kit includes a printed circuit board populated with the ADG791G. The evaluation board can be used to evaluate the performance of both the ADG791A and ADG791G. It interfaces to the USB port of a PC, or it can be used as a standalone evaluation board. Software is available with the evaluation board that allows the user to easily program the ADG791G through the USB port. Schematics of the evaluation board are shown in Figure 33 and Figure 34. The software runs on any PC that has Microsoft® Windows® 2000 or Windows XP installed.

USING THE ADG791G EVALUATION BOARD

The ADG791G evaluation kit is a test system designed to simplify the evaluation of the device. Each input/output of the part comes with a socket specifically chosen for easy audio/video evaluation. A data sheet is also available and gives full information on operating the evaluation board.

ADG791A/ADG791G

06033-034

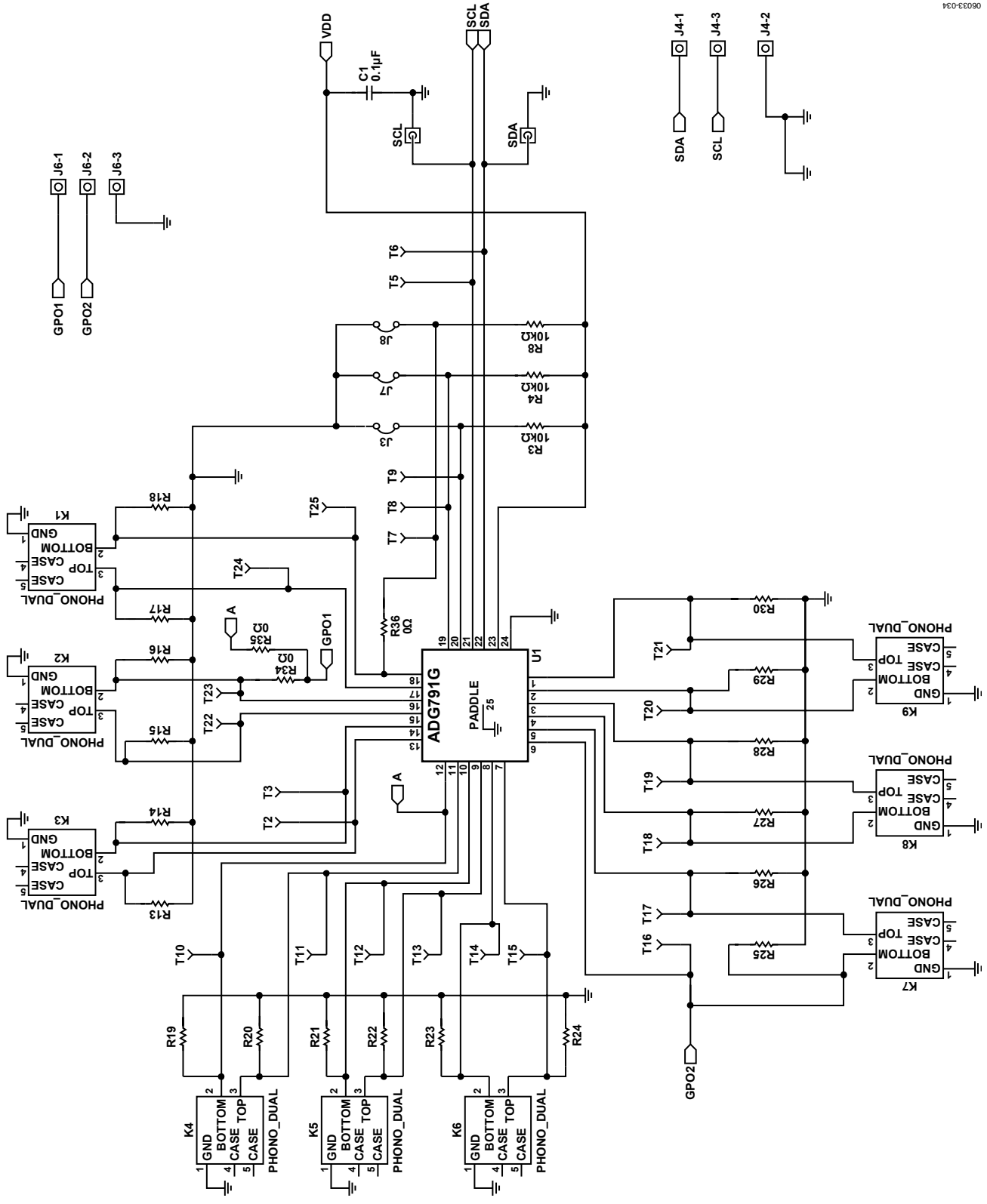
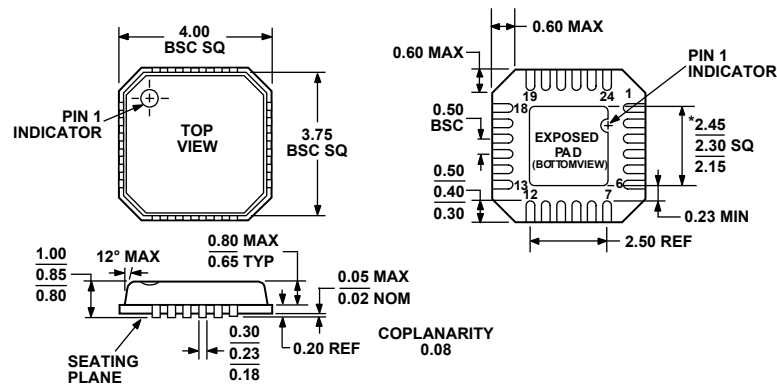

Figure 34. EVAL-ADG791GEB Schematic, Chip Section

OUTLINE DIMENSIONS



*COMPLIANT TO JEDEC STANDARDS MO-220-VGGD-2 EXCEPT FOR EXPOSED PAD DIMENSION

Figure 35. 24-Lead Lead Frame Chip Scale Package [LFCSP_VQ]
 4 mm x 4 mm Body, Very Thin Quad
 (CP-24-2)
 Dimensions shown in millimeters

ORDERING GUIDE

Model	Temperature Range	I ² C Speed	Package Description	Package Option
ADG791ABCPZ-REEL ¹	-40°C to +85°C	100 kHz, 400 kHz	24-Lead LFCSP_VQ	CP-24-2
ADG791ABCPZ-500RL7 ¹	-40°C to +85°C	100 kHz, 400 kHz	24-Lead LFCSP_VQ	CP-24-2
ADG791ACCPZ-REEL ¹	-40°C to +85°C	100 kHz, 400 kHz, 3.4 MHz	24-Lead LFCSP_VQ	CP-24-2
ADG791ACCPZ-500RL7 ¹	-40°C to +85°C	100 kHz, 400 kHz, 3.4 MHz	24-Lead LFCSP_VQ	CP-24-2
ADG791GBCPZ-REEL ¹	-40°C to +85°C	100 kHz, 400 kHz	24-Lead LFCSP_VQ	CP-24-2
ADG791GBCPZ-500RL7 ¹	-40°C to +85°C	100 kHz, 400 kHz	24-Lead LFCSP_VQ	CP-24-2
ADG791GCCPZ-REEL ¹	-40°C to +85°C	100 kHz, 400 kHz, 3.4 MHz	24-Lead LFCSP_VQ	CP-24-2
ADG791GCCPZ-500RL7 ¹	-40°C to +85°C	100 kHz, 400 kHz, 3.4 MHz	24-Lead LFCSP_VQ	CP-24-2
EVAL-ADG791GEB ²			Evaluation Board	

¹ Z = Pb-free part.

² Evaluation board is RoHS compliant.

NOTES

Purchase of licensed I²C components of Analog Devices or one of its sublicensed Associated Companies conveys a license for the purchaser under the Philips I²C Patent Rights to use these components in an I²C system, provided that the system conforms to the I²C Standard Specification as defined by Philips.

Looking for pricing, stock, or lifecycle information?

Click below to explore more details on WIN SOURCE:

- ⊖ [View ADG791ABCPZ-500RL7 on WIN SOURCE](#)
- ⊖ [Analog Devices Inc. Information](#)

Optimize Your Supply Chain with WIN SOURCE Solutions

- ✓ Global Sourcing Solution
- ✓ Obsolete Management
- ✓ Cost Control Management
- ✓ Shortage Management
- ✓ Alternative Solution
- ✓ Excess Inventory Management