



**THE DATASHEET OF
ADN4665ARUZ**



FEATURES

- ±15 kV ESD protection on output pins**
- 400 Mbps (200 MHz) switching rates**
- 100 ps typical differential skew**
- 400 ps maximum differential skew**
- 2 ns maximum propagation delay**
- 3.3 V power supply**
- ±350 mV differential signaling**
- Low power dissipation (13 mW typical)**
- Interoperable with existing 5 V LVDS receivers**
- High impedance on LVDS outputs on power-down**
- Conforms to TIA/EIA-644 LVDS standards**
- Industrial operating temperature range: -40°C to +85°C**
- Available in surface-mount SOIC package and low profile TSSOP package**

APPLICATIONS

- Backplane data transmission**
- Cable data transmission**
- Clock distribution**

GENERAL DESCRIPTION

The ADN4665 is a quad-channel, CMOS, low voltage differential signaling (LVDS) line driver offering data rates of over 400 Mbps (200 MHz) and ultralow power consumption.

The device accepts low voltage TTL/CMOS logic signals and converts them to a differential current output of typically ±3.5 mA for driving a transmission medium such as a twisted pair cable. The transmitted signal develops a differential voltage of typically ±350 mV across a termination resistor at the receiving end. This voltage is converted back to a TTL/CMOS logic level by an LVDS receiver.

FUNCTIONAL BLOCK DIAGRAM

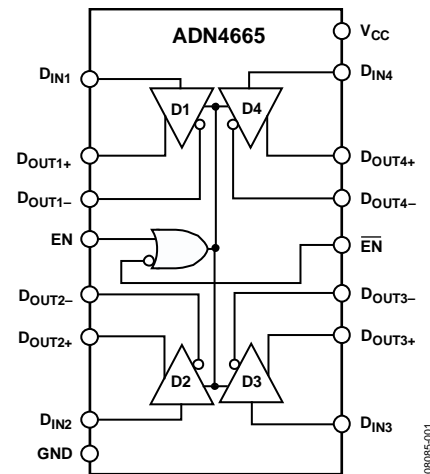

Figure 1.

The ADN4665 also offers active high and active low enable/disable inputs (EN and $\overline{\text{EN}}$). These inputs control all four drivers and turn off the current outputs in the disabled state to reduce the quiescent power consumption to typically 10 mW.

The ADN4665 offers a new solution to high speed, point-to-point data transmission and offers a low power alternative to emitter-coupled logic (ECL) or positive emitter-coupled logic (PECL).

Rev. 0

Information furnished by Analog Devices is believed to be accurate and reliable. However, no responsibility is assumed by Analog Devices for its use, nor for any infringements of patents or other rights of third parties that may result from its use. Specifications subject to change without notice. No license is granted by implication or otherwise under any patent or patent rights of Analog Devices. Trademarks and registered trademarks are the property of their respective owners.

TABLE OF CONTENTS

Features	1	ESD Caution.....	6
Applications.....	1	Pin Configuration and Function Descriptions.....	7
Functional Block Diagram	1	Typical Performance Characteristics	8
General Description	1	Theory of Operation	9
Revision History	2	Enable Inputs	9
Specifications.....	3	Applications Information.....	9
Timing Characteristics	4	Outline Dimensions	10
Absolute Maximum Ratings.....	6	Ordering Guide	10

REVISION HISTORY

5/09—Revision 0: Initial Version

SPECIFICATIONS

$V_{CC} = 3.0\text{ V}$ to 3.6 V , $R_L = 100\ \Omega$, $C_L = 15\text{ pF}$ to GND, all specifications T_{MIN} to T_{MAX} , unless otherwise noted. All typical values are given for $V_{CC} = 3.3\text{ V}$, $T_A = 25^\circ\text{C}$.

Table 1.

Parameter	Symbol	Min	Typ	Max	Unit	Conditions/Comments ^{1, 2}
LVDS OUTPUTS (D_{OUTx+}, D_{OUTx-})						
Differential Output Voltage	V_{OD}	250	350	450	mV	See Figure 2 and Figure 4
Change in Magnitude of V_{OD} for Complementary Output States	ΔV_{OD}		4	35	mV	See Figure 2 and Figure 4
Offset Voltage	V_{OS}	1.125	1.25	1.375	V	See Figure 2 and Figure 4
Change in Magnitude of V_{OS} for Complementary Output States	ΔV_{OS}		5	25	mV	See Figure 2 and Figure 4
Output High Voltage	V_{OH}		1.38	1.6	V	See Figure 2 and Figure 4
Output Low Voltage	V_{OL}	0.90	1.03		V	See Figure 2 and Figure 4
INPUTS (D_{INx}, EN, $\overline{\text{EN}}$)						
Input High Voltage	V_{IH}	2.0		V_{CC}	V	
Input Low Voltage	V_{IL}	GND		0.8	V	
Input High Current	I_{IH}	-10	+1	+10	μA	$V_{IN} = V_{CC}$ or 2.5 V
Input Low Current	I_{IL}	-10	+1	+10	μA	$V_{IN} = \text{GND}$ or 0.4 V
Input Clamp Voltage	V_{CL}	-1.5	-0.8		V	$I_{CL} = -18\text{ mA}$
LVDS OUTPUT PROTECTION (D_{OUTx+}, D_{OUTx-})						
Output Short-Circuit Current ³	I_{OS}		-6.0	-9.0	mA	Enabled, $D_{INx} = V_{CC}$, $D_{OUTx+} = 0\text{ V}$ or $D_{INx} = \text{GND}$, $D_{OUTx-} = 0\text{ V}$
Differential Output Short-Circuit Current ³	I_{OSD}		-6.0	-9.0	mA	Enabled, $V_{OD} = 0\text{ V}$
LVDS OUTPUT LEAKAGE (D_{OUTx+}, D_{OUTx-})						
Power-Off Leakage	I_{OFF}	-20	± 1	+20	μA	$V_{OUT} = 0\text{ V}$ or 3.6 V , $V_{CC} = 0\text{ V}$ or open
Output Three-State Current	I_{OZ}	-10	± 1	+10	μA	$\text{EN} = 0.8\text{ V}$, $\overline{\text{EN}} = 2.0\text{ V}$, $V_{OUT} = 0\text{ V}$ or V_{CC}
POWER SUPPLY						
No Load Supply Current, Drivers Enabled	I_{CC}		5.0	8.0	mA	$D_{INx} = V_{CC}$ or GND
Loaded Supply Current, Drivers Enabled	I_{CCL}		23	30	mA	$R_L = 100\ \Omega$ all channels, $D_{INx} = V_{CC}$ or GND (all inputs)
No Load Supply Current, Drivers Disabled	I_{CCZ}		2.6	6.0	mA	$D_{INx} = V_{CC}$ or GND, $\text{EN} = \text{GND}$, $\overline{\text{EN}} = V_{CC}$
ESD PROTECTION						
D_{OUTx+} , D_{OUTx-} Pins			± 15		kV	Human body model
All Pins Except D_{OUTx+} , D_{OUTx-}			± 4.5		kV	Human body model

¹ Current into device pins is defined as positive. Current out of device pins is defined as negative. All voltages are referenced to ground except V_{OD} , ΔV_{OD} , and ΔV_{OS} .

² The ADN4665 is a current-mode device and functions within data sheet specifications only when a resistive load is applied to the driver outputs. Typical range is $90\ \Omega$ to $110\ \Omega$.

³ Output short-circuit current (I_{OS}) is specified as magnitude only; minus sign indicates direction only.

ADN4665

TIMING CHARACTERISTICS

$V_{CC} = 3.0\text{ V to }3.6\text{ V}$, $R_L = 100\ \Omega$, $C_L^1 = 15\text{ pF to GND}$, all specifications T_{MIN} to T_{MAX} , unless otherwise noted. All typical values are given for $V_{CC} = 3.3\text{ V}$, $T_A = 25^\circ\text{C}$.

Table 2.

Parameter ²	Symbol	Min	Typ	Max	Unit	Conditions/Comments ^{3, 4}
AC CHARACTERISTICS						
Differential Propagation Delay, High to Low	t_{PHLD}	0.8	1.18	2.0	ns	See Figure 3 and Figure 4
Differential Propagation Delay, Low to High	t_{PLHD}	0.8	1.25	2.0	ns	See Figure 3 and Figure 4
Differential Pulse Skew $ t_{PHLD} - t_{PLHD} $	t_{SKD1}^5	0	0.07	0.4	ns	See Figure 3 and Figure 4
Channel-to-Channel Skew	t_{SKD2}^6	0	0.1	0.5	ns	See Figure 3 and Figure 4
Differential Part-to-Part Skew	t_{SKD3}^7	0		1.0	ns	See Figure 3 and Figure 4
Differential Part-to-Part Skew	t_{SKD4}^8	0		1.2	ns	See Figure 3 and Figure 4
Rise Time	t_{TLH}		0.38	1.5	ns	See Figure 3 and Figure 4
Fall Time	t_{THL}		0.4	1.5	ns	See Figure 3 and Figure 4
Disable Time High to Inactive	t_{PHZ}			5	ns	See Figure 5 and Figure 6
Disable Time Low to Inactive	t_{PLZ}			5	ns	See Figure 5 and Figure 6
Enable Time Inactive to High	t_{PZH}			7	ns	See Figure 5 and Figure 6
Enable Time Inactive to Low	t_{PZL}			7	ns	See Figure 5 and Figure 6
Maximum Operating Frequency	f_{MAX}^9	200	250		MHz	See Figure 5 and Figure 6

¹ C_L includes probe and jig capacitance.

² AC parameters are guaranteed by design and characterization.

³ Generator waveform for all tests, unless otherwise specified: $f = 50\text{ MHz}$, $Z_0 = 50\ \Omega$, $t_r \leq 1\text{ ns}$, and $t_f \leq 1\text{ ns}$.

⁴ All input voltages are for one channel, unless otherwise specified. Other inputs are set to GND.

⁵ $t_{SKD1} = |t_{PHLD} - t_{PLHD}|$ is the magnitude difference in differential propagation delay time between the positive-going edge and the negative-going edge of the same channel.

⁶ t_{SKD2} is the differential channel-to-channel skew of any event on the same device.

⁷ t_{SKD3} , differential part-to-part skew, is defined as the difference between the minimum and maximum specified differential propagation delays. This specification applies to devices at the same V_{CC} and within 5°C of each other within the operating temperature range.

⁸ t_{SKD4} , part-to-part skew, is the differential channel-to-channel skew of any event between devices. This specification applies to devices over the recommended operating temperature and voltage ranges, and across process distribution. t_{SKD4} is defined as $|\text{maximum} - \text{minimum}|$ differential propagation delay.

⁹ f_{MAX} generator input conditions: $t_r = t_f < 1\text{ ns}$ (0% to 100%), 50% duty cycle, 0 V to 3 V. Output criteria: duty cycle = 45% to 55%, $V_{OD} > 250\text{ mV}$, all channels switching.

Test Circuits and Timing Diagrams

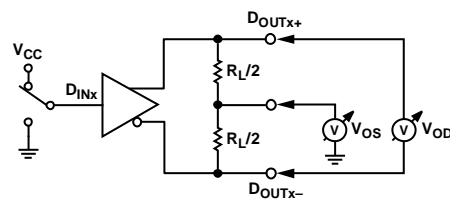

NOTES
1. DRIVER IS ENABLED.

Figure 2. Test Circuit for Driver V_{OD} and V_{OS}

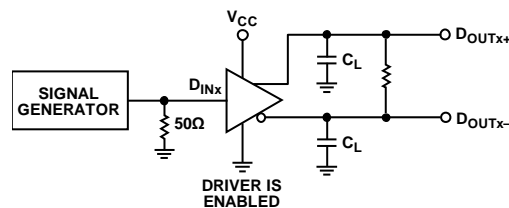

NOTES
1. C_L INCLUDES PROBE AND JIG CAPACITANCE.

Figure 3. Test Circuit for Driver Propagation Delay and Transition Time

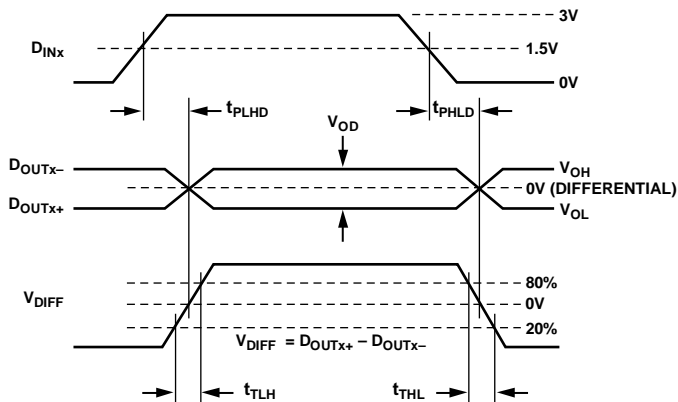
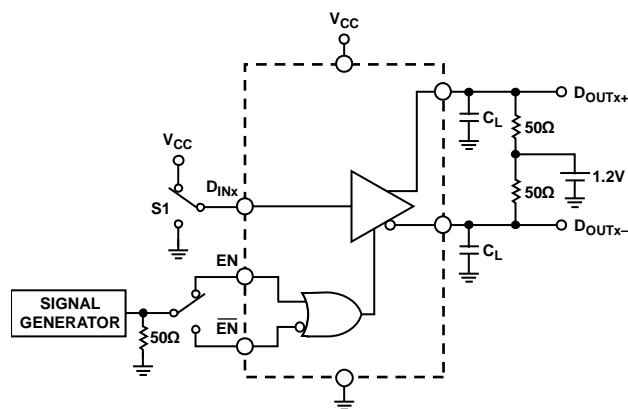

Figure 4. Driver Propagation Delay and Transition Time Waveforms

08085-004



NOTES

1. C_L INCLUDES LOAD AND TEST JIG CAPACITANCE.
2. S1 CONNECTED TO V_{CC} FOR t_{PHZ} AND t_{PZH} TEST.
3. S1 CONNECTED TO GND FOR t_{PLZ} AND t_{PZL} TEST.

Figure 5. Test Circuit for Driver Three-State Delay

08085-005

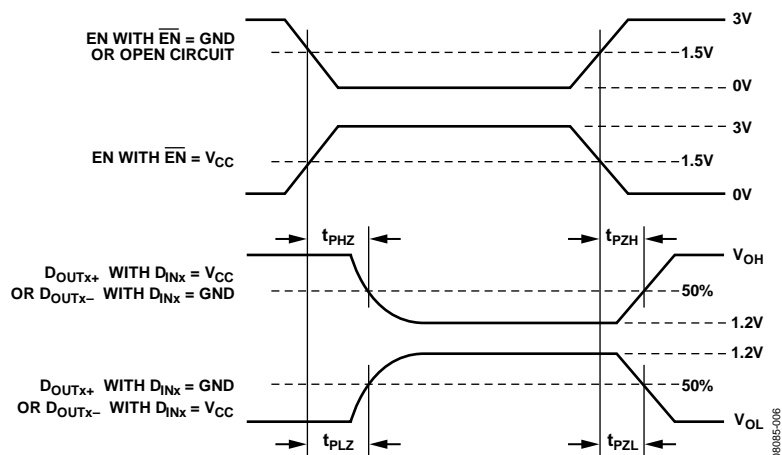

Figure 6. Driver Three-State Delay Waveforms

08085-006

ABSOLUTE MAXIMUM RATINGS

$T_A = 25^\circ\text{C}$, unless otherwise noted.

Table 3.

Parameter	Rating
V_{CC} to GND	-0.3 V to +4 V
Input Voltage (D_{INx}) to GND	-0.3 V to $V_{CC} + 0.3$ V
Enable Input Voltage (EN, \overline{EN}) to GND	-0.3 V to $V_{CC} + 0.3$ V
Output Voltage (D_{OUTx+}, D_{OUTx-}) to GND	-0.3 V to $V_{CC} + 0.3$ V
Short-Circuit Duration (D_{OUTx+}, D_{OUTx-}) to GND	Continuous
Industrial Operating Temperature Range	-40°C to $+85^\circ\text{C}$
Storage Temperature Range	-65°C to $+150^\circ\text{C}$
Junction Temperature (T_J max)	150°C
Power Dissipation	$(T_J \text{ max} - T_A)/\theta_{JA}$
θ_{JA} Thermal Impedance	
TSSOP Package	$150.4^\circ\text{C}/\text{W}$
SOIC Package	$125^\circ\text{C}/\text{W}$
Reflow Soldering Peak Temperature (10 sec)	260°C max

Stresses above those listed under Absolute Maximum Ratings may cause permanent damage to the device. This is a stress rating only; functional operation of the device at these or any other conditions above those indicated in the operational section of this specification is not implied. Exposure to absolute maximum rating conditions for extended periods may affect device reliability.

ESD CAUTION



ESD (electrostatic discharge) sensitive device. Charged devices and circuit boards can discharge without detection. Although this product features patented or proprietary protection circuitry, damage may occur on devices subjected to high energy ESD. Therefore, proper ESD precautions should be taken to avoid performance degradation or loss of functionality.

PIN CONFIGURATION AND FUNCTION DESCRIPTIONS

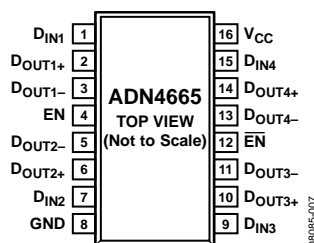

Figure 7. Pin Configuration

Table 4. Pin Function Descriptions

Pin No.	Mnemonic	Description
1	D _{IN1}	Driver Channel 1 Logic Input.
2	D _{OUT1+}	Channel 1 Noninverting Output Current Driver. When D _{IN1} is high, current flows out of D _{OUT1+} . When D _{IN1} is low, current flows into D _{OUT1+} .
3	D _{OUT1-}	Channel 1 Inverting Output Current Driver. When D _{IN1} is high, current flows into D _{OUT1-} . When D _{IN1} is low, current flows out of D _{OUT1-} .
4	EN	Active High Enable and Power-Down Input (3 V TTL/CMOS). If $\overline{\text{EN}}$ is held low or open circuit, EN enables the drivers when high and disables the drivers when low.
5	D _{OUT2-}	Channel 2 Inverting Output Current Driver. When D _{IN2} is high, current flows into D _{OUT2-} . When D _{IN2} is low, current flows out of D _{OUT2-} .
6	D _{OUT2+}	Channel 2 Noninverting Output Current Driver. When D _{IN2} is high, current flows out of D _{OUT2+} . When D _{IN2} is low, current flows into D _{OUT2+} .
7	D _{IN2}	Driver Channel 2 Logic Input.
8	GND	Ground Reference Point for All Circuitry on the Part.
9	D _{IN3}	Driver Channel 3 Logic Input.
10	D _{OUT3+}	Channel 3 Noninverting Output Current Driver. When D _{IN3} is high, current flows out of D _{OUT3+} . When D _{IN3} is low, current flows into D _{OUT3+} .
11	D _{OUT3-}	Channel 3 Inverting Output Current Driver. When D _{IN3} is high, current flows into D _{OUT3-} . When D _{IN3} is low, current flows out of D _{OUT3-} .
12	$\overline{\text{EN}}$	Active Low Enable and Power-Down Input with Pull-Down (3 V TTL/CMOS). If EN is held high, $\overline{\text{EN}}$ enables the drivers when low or open circuit and disables the drivers and powers down the device when high.
13	D _{OUT4-}	Channel 4 Inverting Output Current Driver. When D _{IN4} is high, current flows into D _{OUT4-} . When D _{IN4} is low, current flows out of D _{OUT4-} .
14	D _{OUT4+}	Channel 4 Noninverting Output Current Driver. When D _{IN4} is high, current flows out of D _{OUT4+} . When D _{IN4} is low, current flows into D _{OUT4+} .
15	D _{IN4}	Driver Channel 4 Logic Input.
16	V _{CC}	Power Supply Input. This part can be operated from 3.0 V to 3.6 V. The supply should be decoupled with a 10 μF solid tantalum capacitor in parallel with a 0.1 μF capacitor to GND.

TYPICAL PERFORMANCE CHARACTERISTICS

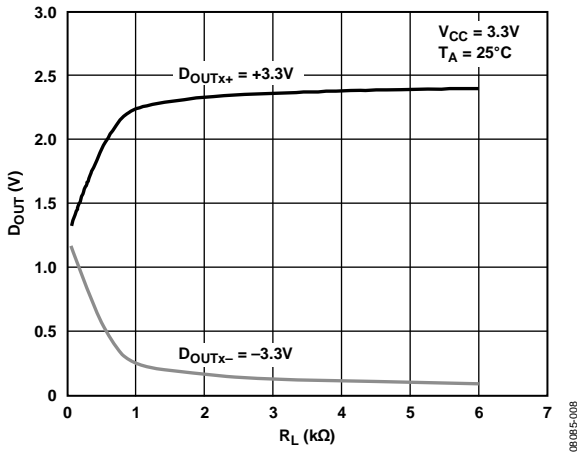

Figure 8. Single-Ended Driver Output Voltage vs. Load Resistance

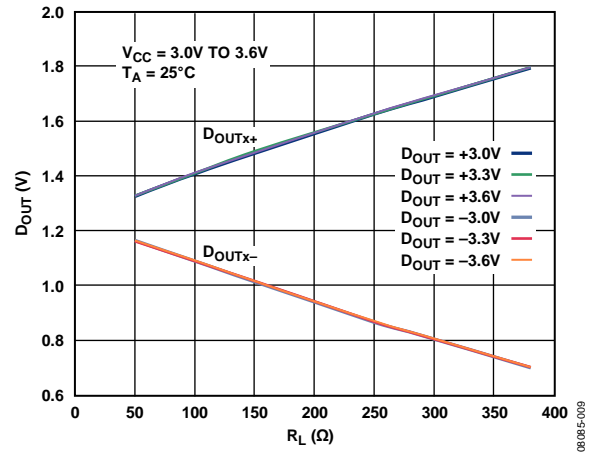

Figure 9. Driver Output vs. Load Resistance

THEORY OF OPERATION

The ADN4665 is a quad line driver for low voltage differential signaling. It takes a single-ended 3 V logic signal and converts it to a differential current output. The data can then be transmitted for considerable distances, over media such as a twisted pair cable or PCB backplane, to an LVDS receiver such as the ADN4666, where it develops a voltage across a termination resistor, R_T . This resistor is chosen to match the characteristic impedance of the medium, typically around 100 Ω . The differential voltage is detected by the receiver and converted back into a single-ended logic signal.

When D_{INx} is high (Logic 1), current flows out of the D_{OUTx+} pin (current source) through R_T and back into the D_{OUTx-} pin (current sink). At the receiver, this current develops a positive differential voltage across R_T (with respect to the inverting input) and results in a Logic 1 at the receiver output. When D_{INx} is low, D_{OUTx+} sinks current and D_{OUTx-} sources current; a negative differential voltage across R_T results in a Logic 0 at the receiver output.

The output drive current is between ± 2.5 mA and ± 4.5 mA (typically ± 3.5 mA), developing between ± 250 mV and ± 450 mV across a 100 Ω termination resistor. The received voltage is centered around the receiver offset of 1.25 V. Therefore, the noninverting receiver input is typically 1.375 V (that is, 1.2 V + [350 mV/2]) and the inverting receiver input is 1.025 V (that is, 1.2 V - [350 mV/2]) for Logic 1. For Logic 0, the inverting and noninverting output voltages are reversed. Note that because the differential voltage reverses polarity, the peak-to-peak voltage swing across R_T is twice the differential voltage.

Current-mode drivers offer considerable advantages over voltage-mode drivers such as RS-422 drivers. The operating current remains fairly constant with increased switching frequency, whereas the operating current of voltage-mode drivers increases exponentially in most cases. This is caused by the overlap current as internal gates switch between high and low, which causes currents to flow from the device power supply to ground. A current-mode device simply reverses a constant current between its two outputs, with no significant overlap currents.

This is similar to emitter-coupled logic (ECL) and positive emitter-coupled logic (PECL), but without the high quiescent current of ECL and PECL.

ENABLE INPUTS

The active high and active low enable inputs deactivate all the current drivers when the drivers are in the disabled state. This also powers down the device and reduces the current consumption from typically 23 mA to typically 2.6 mA. A truth table for the enable inputs is shown in Table 5.

Table 5. Enable Inputs Truth Table

Pin Logic Level			D_{OUTx+}	D_{OUTx-}
EN	$\overline{\text{EN}}$	D_{INx}		
Low	High	X ¹	Inactive	Inactive
Low	Low	Low	I_{SINK}	I_{SOURCE}
Low	Low	High	I_{SOURCE}	I_{SINK}
High	Low	Low	I_{SINK}	I_{SOURCE}
High	Low	High	I_{SOURCE}	I_{SINK}

¹ X = don't care.

APPLICATIONS INFORMATION

Figure 10 shows a typical application for point-to-point data transmission using the ADN4665 as the driver.

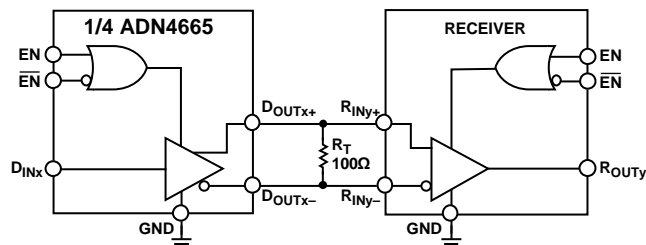
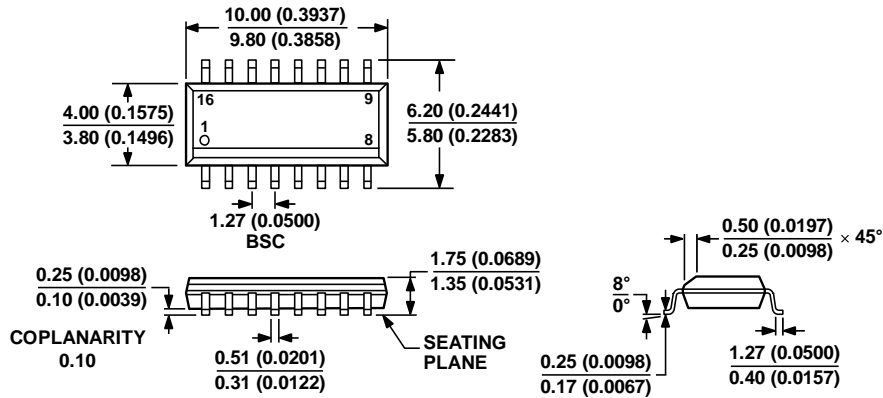

Figure 10. Typical Application Circuit

08085-010

OUTLINE DIMENSIONS



COMPLIANT TO JEDEC STANDARDS MS-012-AC

CONTROLLING DIMENSIONS ARE IN MILLIMETERS; INCH DIMENSIONS (IN PARENTHESES) ARE ROUNDED-OFF MILLIMETER EQUIVALENTS FOR REFERENCE ONLY AND ARE NOT APPROPRIATE FOR USE IN DESIGN.

Figure 11. 16-Lead Standard Small Outline Package [SOIC_N]
Narrow Body
(R-16)

Dimensions shown in millimeters and (inches)

06060E-A

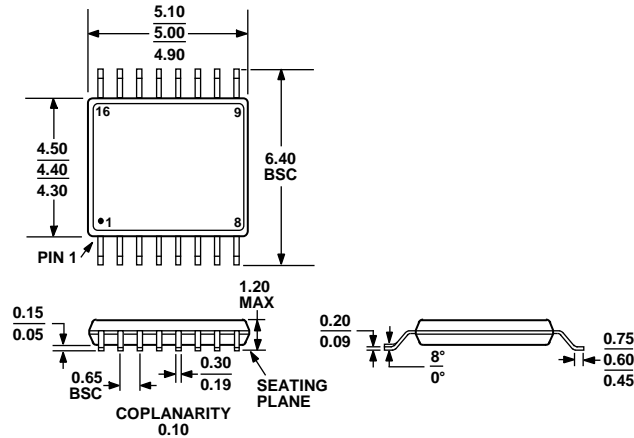

COMPLIANT TO JEDEC STANDARDS MO-153-AB

Figure 12. 16-Lead Thin Shrink Small Outline Package [TSSOP]
(RU-16)

Dimensions shown in millimeters

ORDERING GUIDE

Model	Temperature Range	Package Description	Package Option
ADN4665ARZ ¹	-40°C to +85°C	16-Lead Standard Small Outline Package [SOIC_N]	R-16
ADN4665ARZ-REEL7 ¹	-40°C to +85°C	16-Lead Standard Small Outline Package [SOIC_N]	R-16
ADN4665ARUZ ¹	-40°C to +85°C	16-Lead Thin Shrink Small Outline Package [TSSOP]	RU-16
ADN4665ARUZ-REEL7 ¹	-40°C to +85°C	16-Lead Thin Shrink Small Outline Package [TSSOP]	RU-16

¹ Z = RoHS Compliant Part.

NOTES

ADN4665

NOTES

Looking for pricing, stock, or lifecycle information?

Click below to explore more details on WIN SOURCE:

 [View ADN4665ARUZ on WIN SOURCE](#)

 [Analog Devices Inc. Information](#)

Optimize Your Supply Chain with WIN SOURCE Solutions

-  Global Sourcing Solution
-  Obsolete Management
-  Cost Control Management
-  Shortage Management
-  Alternative Solution
-  Excess Inventory Management