

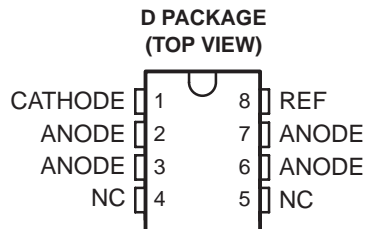

**THE DATASHEET OF
TL1431QDRQ1**



- Qualified for Automotive Applications
- 0.4% Initial Voltage Tolerance
- 0.2-Ω Typical Output Impedance
- Fast Turnon . . . 500 ns
- Sink Current Capability . . . 1 mA to 100 mA
- Low Reference Current (REF)
- Adjustable Output Voltage . . . $V_{I(\text{ref})}$ to 36 V



NC – No internal connection
ANODE terminals are connected internally.

description/ordering information

The TL1431 is a precision programmable reference with specified thermal stability over the automotive temperature range. The output voltage can be set to any value between $V_{I(\text{ref})}$ (approximately 2.5 V) and 36 V with two external resistors (see Figure 16). This device has a typical output impedance of 0.2 Ω. Active output circuitry provides a very sharp turnon characteristic, making the device an excellent replacement for Zener diodes and other types of references in applications such as onboard regulation, adjustable power supplies, and switching power supplies.

The TL1431Q is characterized for operation over the full automotive temperature range of –40°C to 125°C.

ORDERING INFORMATION†

T _A	PACKAGE‡		ORDERABLE PART NUMBER	TOP-SIDE MARKING
–40°C to 125°C	SOIC (D)	Reel of 2500	TL1431QDRQ1	1431Q1

† For the most current package and ordering information, see the Package Option Addendum at the end of this document, or see the TI web site at <http://www.ti.com>.

‡ Package drawings, thermal data, and symbolization are available at <http://www.ti.com/packaging>.

symbol

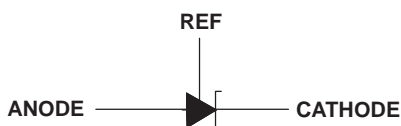

Please be aware that an important notice concerning availability, standard warranty, and use in critical applications of Texas Instruments semiconductor products and disclaimers thereto appears at the end of this data sheet.

PRODUCTION DATA information is current as of publication date. Products conform to specifications per the terms of Texas Instruments standard warranty. Production processing does not necessarily include testing of all parameters.

**TEXAS
INSTRUMENTS**

POST OFFICE BOX 655303 • DALLAS, TEXAS 75265

Copyright © 2008, Texas Instruments Incorporated

TL1431-Q1 PRECISION PROGRAMMABLE REFERENCE

SLVS534B – JUNE 2004 – REVISED APRIL 2008

functional block diagram

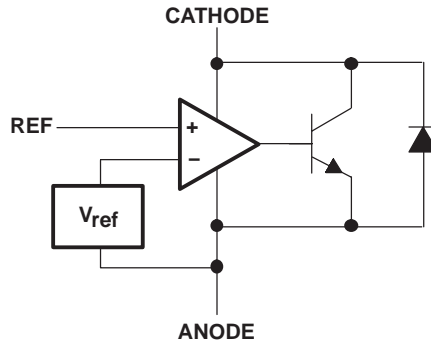

equivalent schematic†

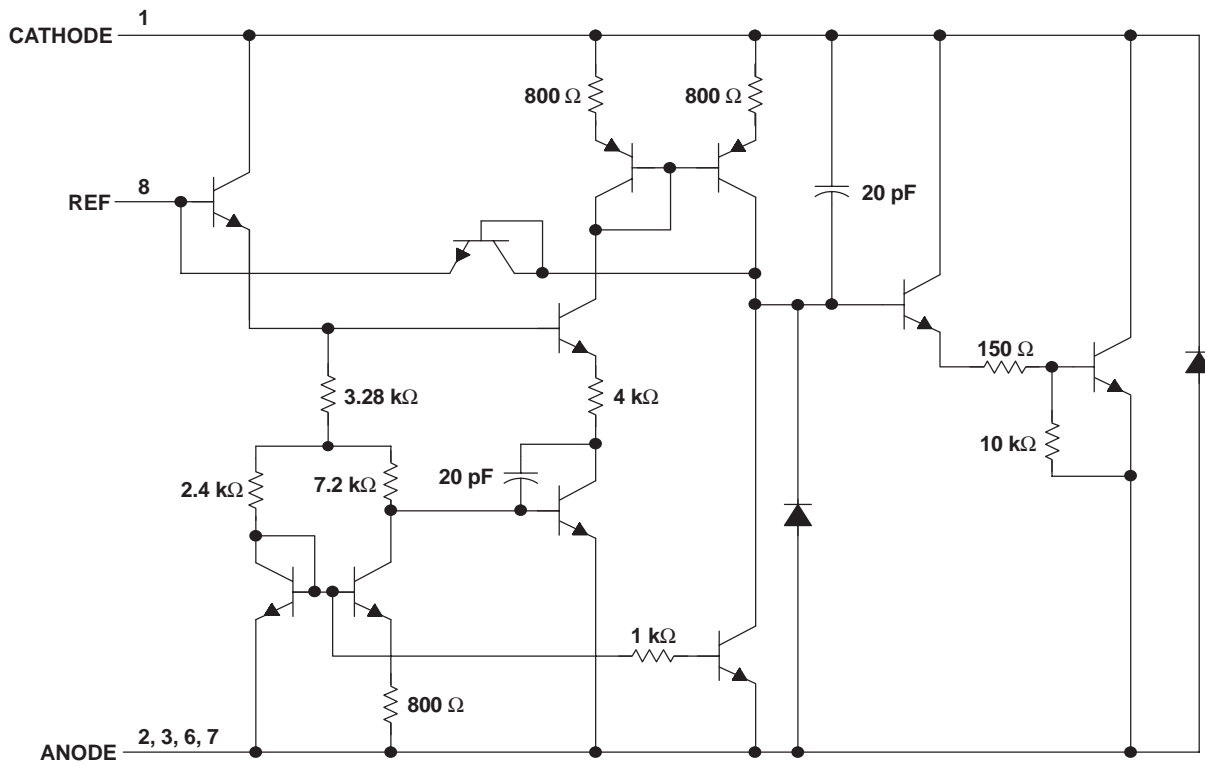

† All component values are nominal.

absolute maximum ratings over operating free-air temperature range (unless otherwise noted)†

Cathode voltage, V_{KA} (see Note 1)	37 V
Continuous cathode current range, I_{KA}	–100 mA to 150 mA
Reference input current range, $I_{I(ref)}$	–50 μ A to 10 mA
Package thermal impedance, θ_{JA} (see Notes 2 and 3)	97°C/W
Operating virtual junction temperature, T_J	150°C
Continuous total power dissipation	See Dissipation Rating Table
Lead temperature 1,6 mm (1/16 inch) from case for 10 seconds	260°C
Storage temperature range, T_{stg}	–65°C to 150°C

† Stresses beyond those listed under “absolute maximum ratings” may cause permanent damage to the device. These are stress ratings only, and functional operation of the device at these or any other conditions beyond those indicated under “recommended operating conditions” is not implied. Exposure to absolute-maximum-rated conditions for extended periods may affect device reliability.

- NOTES: 1. All voltage values are with respect to ANODE, unless otherwise noted.
 2. Temperature and/or supply voltages must be limited to ensure that the maximum dissipation rating is not exceeded.
 3. The package thermal impedance is calculated in accordance with JESD 51-7.

DISSIPATION RATING TABLE

PACKAGE	$T_A \leq 25^\circ\text{C}$ POWER RATING	DERATING FACTOR ABOVE $T_A = 25^\circ\text{C}$	$T_A = 70^\circ\text{C}$ POWER RATING	$T_A = 85^\circ\text{C}$ POWER RATING	$T_A = 125^\circ\text{C}$ POWER RATING
D	1102 mW	10.3 mW/°C	638.5 mW	484 mW	72.1 mW

recommended operating conditions

		MIN	MAX	UNIT
V_{KA}	Cathode voltage	$V_{I(ref)}$	36	V
I_{KA}	Cathode current	1	100	mA
T_A	Operating free-air temperature	–40	125	°C

TL1431-Q1 PRECISION PROGRAMMABLE REFERENCE

SLVS534B – JUNE 2004 – REVISED APRIL 2008

electrical characteristics at specified free-air temperature, $I_{KA} = 10 \text{ mA}$ (unless otherwise noted)

PARAMETER	TEST CONDITIONS	T_A †	TEST CIRCUIT	MIN	TYP	MAX	UNIT
$V_{I(\text{ref})}$	Reference input voltage	$V_{KA} = V_{I(\text{ref})}$	Figure 1	2490	2500	2510	mV
		Full range		2470		2530	
$V_{I(\text{dev})}$	Deviation of reference input voltage over full temperature range‡	$V_{KA} = V_{I(\text{ref})}$	Figure 1		17	55	mV
$\frac{\Delta V_{I(\text{ref})}}{\Delta V_{KA}}$	Ratio of change in reference input voltage to the change in cathode voltage	$\Delta V_{KA} = 3 \text{ V to } 36 \text{ V}$	Figure 2		-1.1	-2	mV/V
$I_{I(\text{ref})}$	Reference input current	$R1 = 10 \text{ k}\Omega, R2 = \infty$	Figure 2		1.5	2.5	μA
		Full range				4	
$I_{I(\text{dev})}$	Deviation of reference input current over full temperature range‡	$R1 = 10 \text{ k}\Omega, R2 = \infty$	Figure 2		0.5	2	μA
I_{min}	Minimum cathode current for regulation	$V_{KA} = V_{I(\text{ref})}$	Figure 1		0.45	1	mA
I_{off}	Off-state cathode current	$V_{KA} = 36 \text{ V}, V_{I(\text{ref})} = 0$	Figure 3		0.18	0.5	μA
		Full range				2	
$ z_{KA} $	Output impedance§	$V_{KA} = V_{I(\text{ref})}, f \leq 1 \text{ kHz}, I_{KA} = 1 \text{ mA to } 100 \text{ mA}$	Figure 1		0.2	0.4	Ω

† Full range is -40°C to 125°C for Q-suffix devices.

‡ The deviation parameters $V_{I(\text{dev})}$ and $I_{I(\text{dev})}$ are defined as the differences between the maximum and minimum values obtained over the rated temperature range. The average full-range temperature coefficient of the reference input voltage $\alpha_{V_{I(\text{ref})}}$ is defined as:

$$\left| \alpha_{V_{I(\text{ref})}} \right| \left(\frac{\text{ppm}}{^\circ\text{C}} \right) = \frac{\left(\frac{V_{I(\text{dev})}}{V_{I(\text{ref}) \text{ at } 25^\circ\text{C}}} \right) \times 10^6}{\Delta T_A}$$

where:

ΔT_A is the rated operating temperature range of the device.

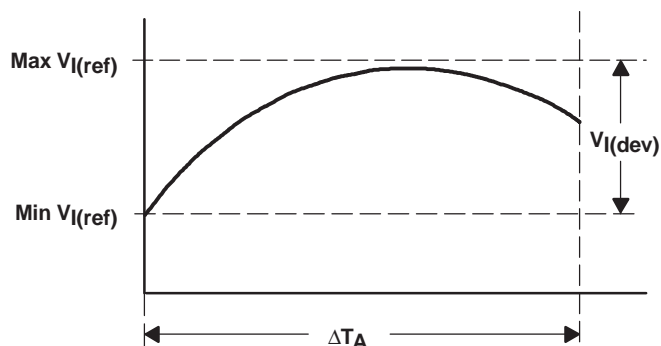

$\alpha_{V_{I(\text{ref})}}$ is positive or negative, depending on whether minimum $V_{I(\text{ref})}$ or maximum $V_{I(\text{ref})}$, respectively, occurs at the lower temperature.

§ The output impedance is defined as: $|z_{KA}| = \frac{\Delta V_{KA}}{\Delta I_{KA}}$

When the device is operating with two external resistors (see Figure 2), the total dynamic impedance of the circuit is given by: $|z'| = \frac{\Delta V}{\Delta I}$,

which is approximately equal to $|z_{KA}| \left(1 + \frac{R1}{R2} \right)$.

PARAMETER MEASUREMENT INFORMATION

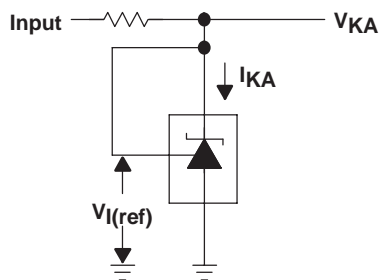

Figure 1. Test Circuit for $V_{(KA)} = V_{ref}$

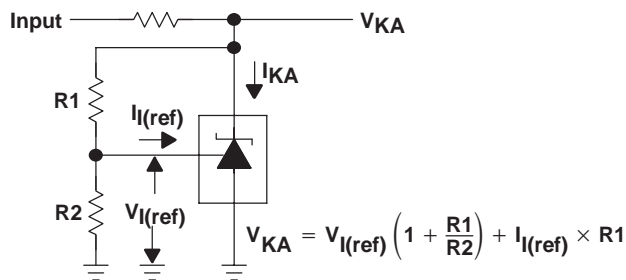

Figure 2. Test Circuit for $V_{(KA)} > V_{ref}$

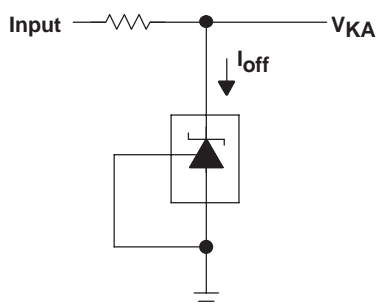

Figure 3. Test Circuit for I_{off}

TYPICAL CHARACTERISTICS

Table of Graphs

	FIGURE
Reference voltage vs Free-air temperature	4
Reference current vs Free-air temperature	5
Cathode current vs Cathode voltage	6, 7
Off-state cathode current vs Free-air temperature	8
Ratio of delta reference voltage to delta cathode voltage vs Free-air temperature	9
Equivalent input-noise voltage vs Frequency	10
Equivalent input-noise voltage over a 10-second period	11
Small-signal voltage amplification vs Frequency	12
Reference impedance vs Frequency	13
Pulse response	14
Stability boundary conditions	15

TL1431-Q1 PRECISION PROGRAMMABLE REFERENCE

SLVS534B – JUNE 2004 – REVISED APRIL 2008

TYPICAL CHARACTERISTICS†

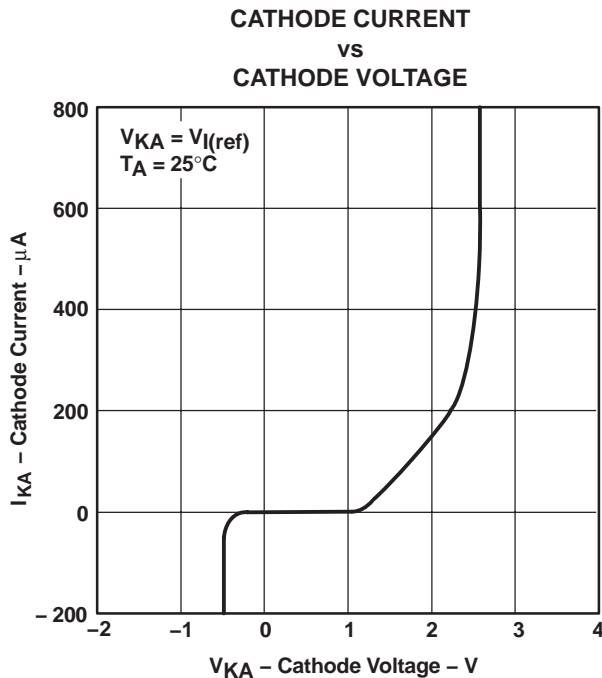
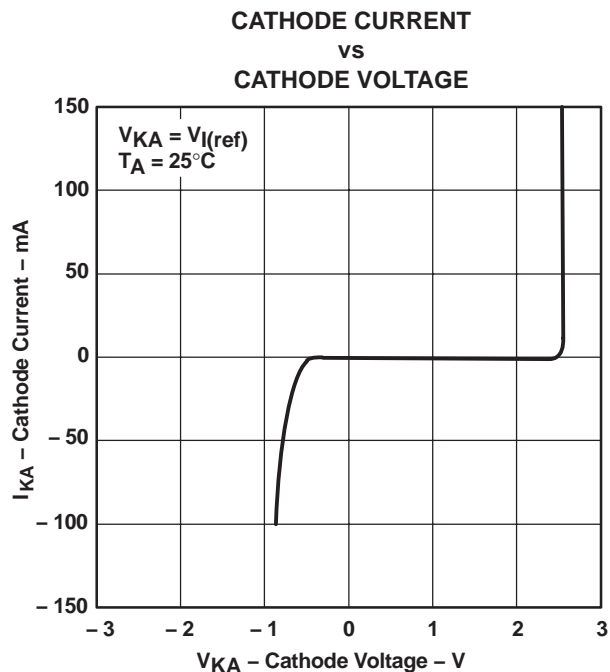
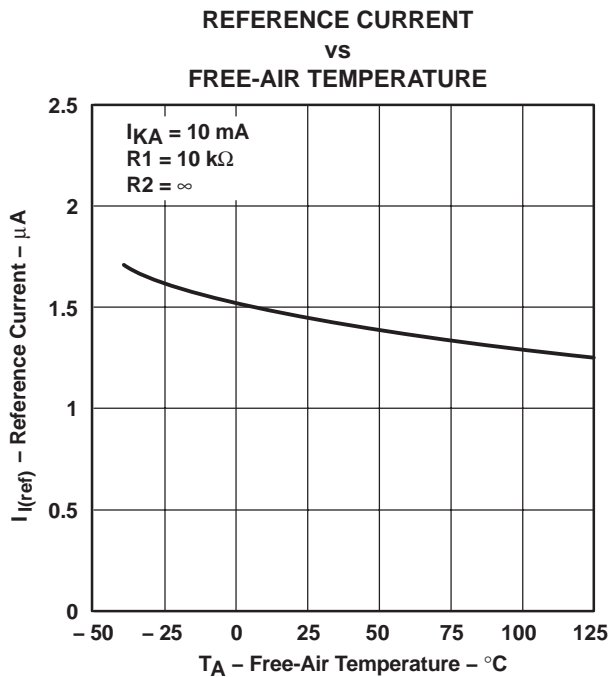
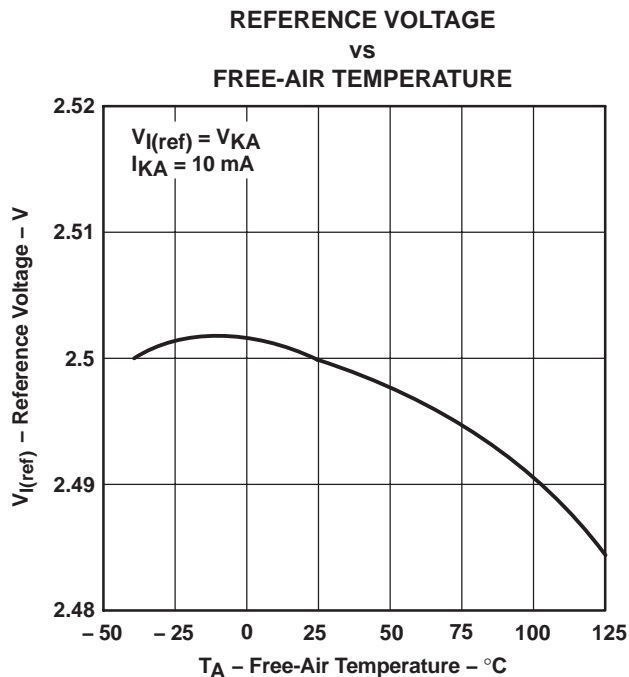

† Data at high and low temperatures are applicable only within the recommended operating free-air temperature ranges of the various devices.

TYPICAL CHARACTERISTICS†

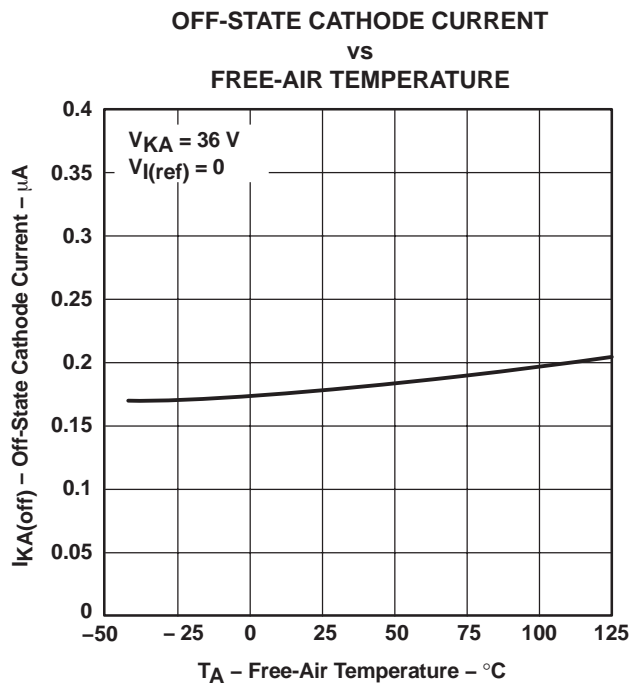

Figure 8

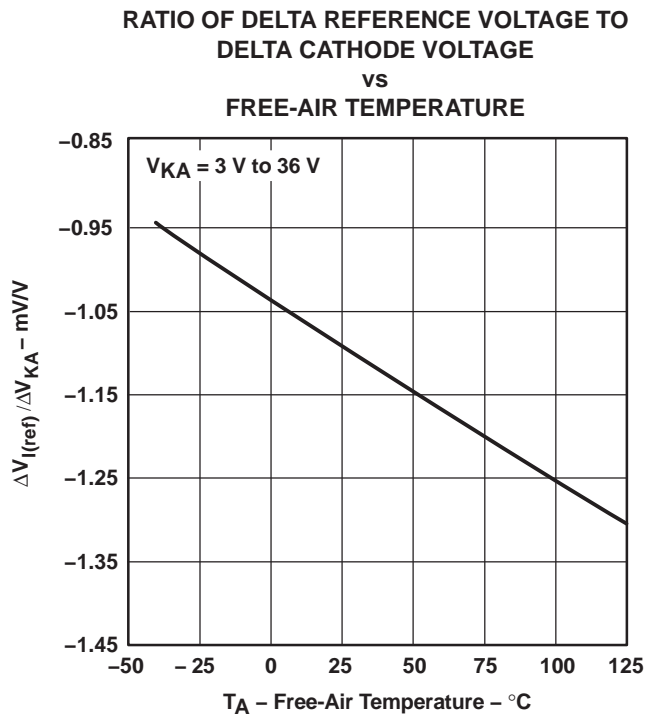

Figure 9

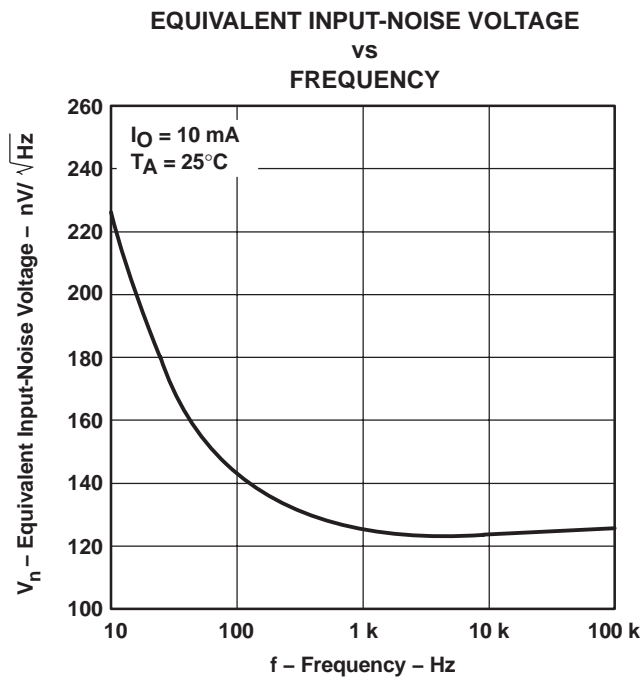

Figure 10

† Data at high and low temperatures are applicable only within the recommended operating free-air temperature ranges of the various devices.

TL1431-Q1 PRECISION PROGRAMMABLE REFERENCE

SLVS534B – JUNE 2004 – REVISED APRIL 2008

TYPICAL CHARACTERISTICS

EQUIVALENT INPUT-NOISE VOLTAGE OVER A 10-SECOND PERIOD

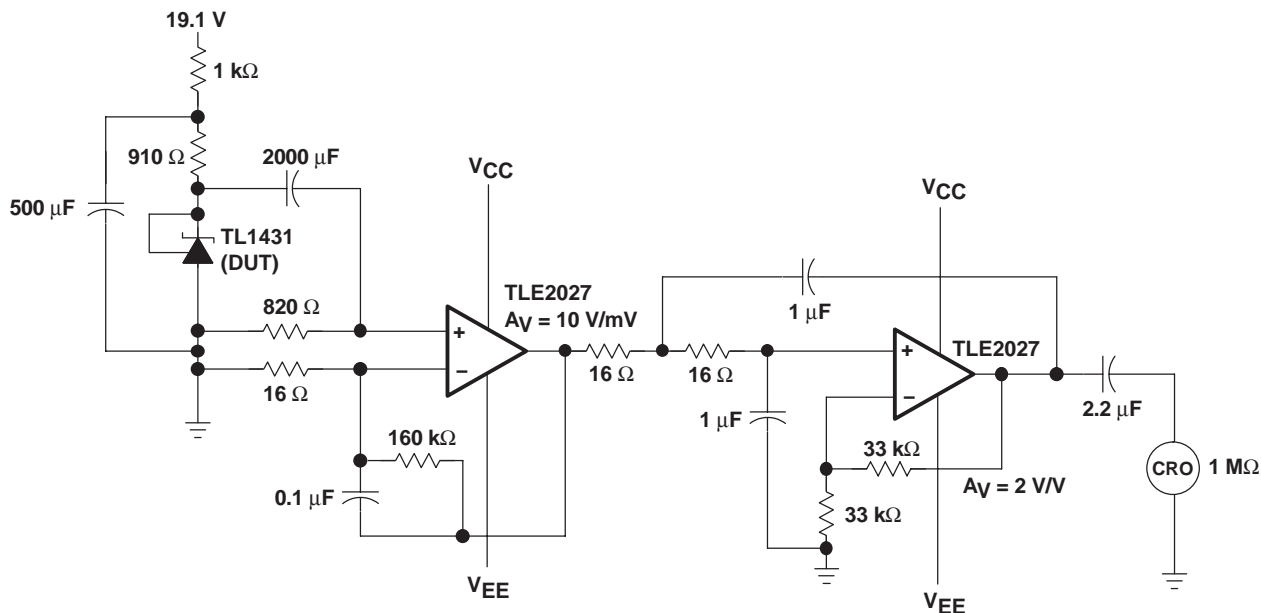
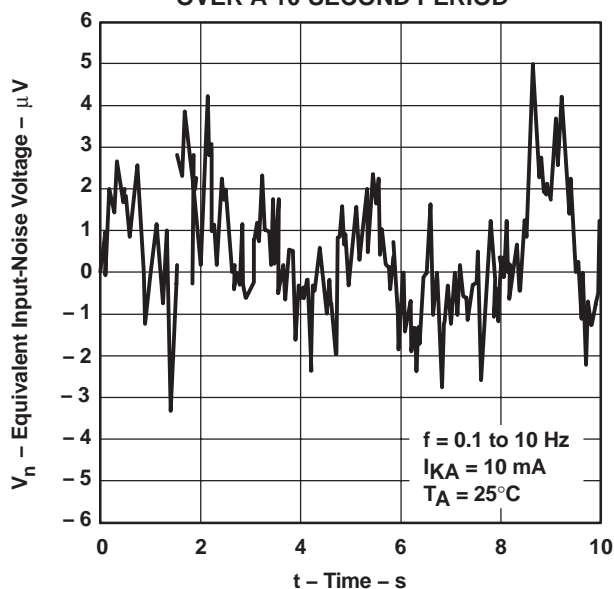

TEST CIRCUIT FOR 0.1-Hz TO 10-Hz EQUIVALENT INPUT-NOISE VOLTAGE

Figure 11

TYPICAL CHARACTERISTICS

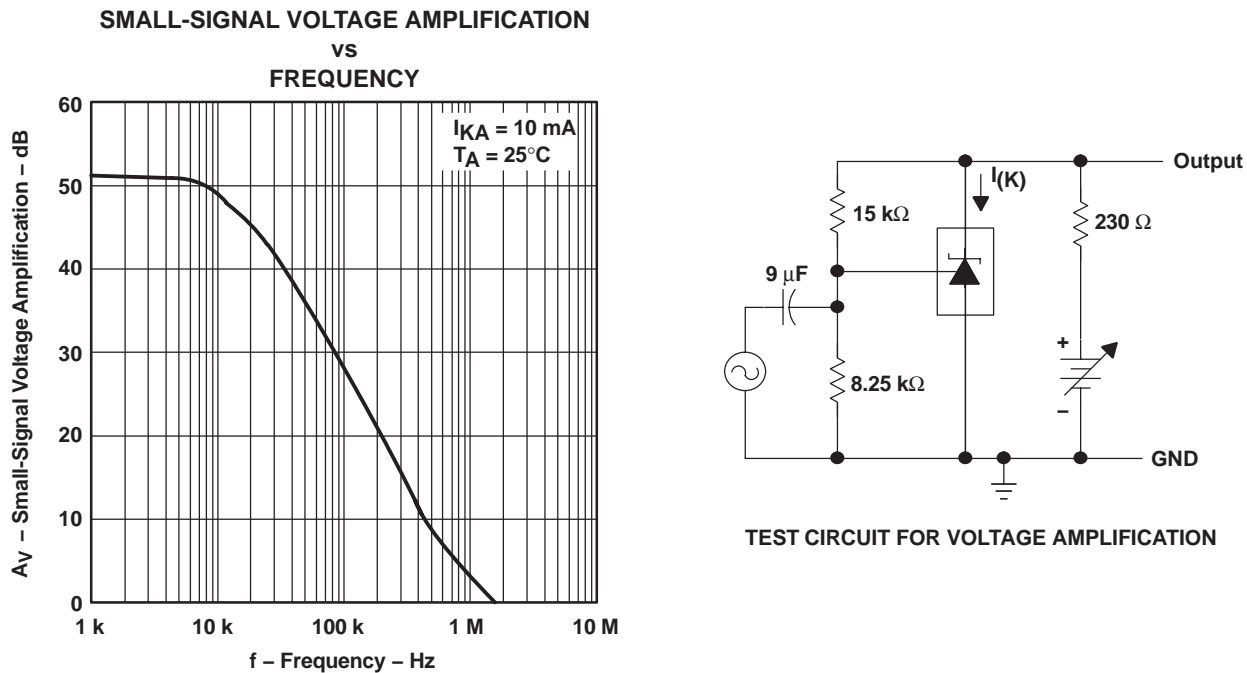

Figure 12

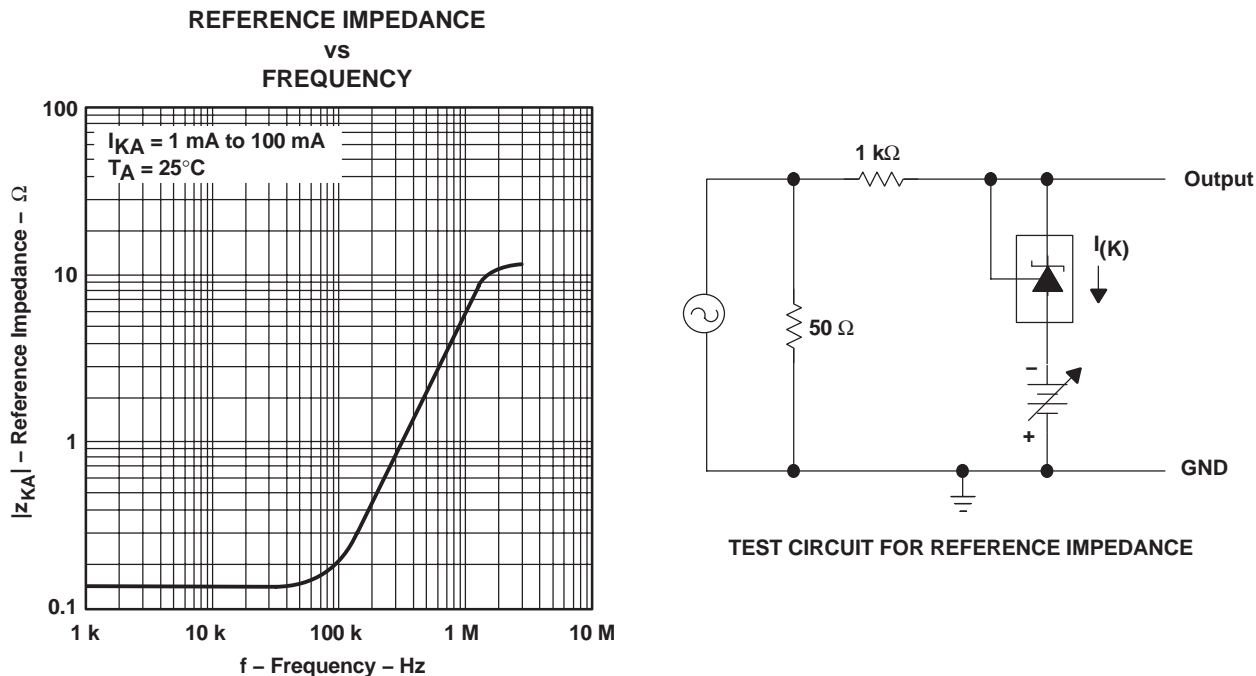

Figure 13

TL1431-Q1 PRECISION PROGRAMMABLE REFERENCE

SLVS534B – JUNE 2004 – REVISED APRIL 2008

TYPICAL CHARACTERISTICS

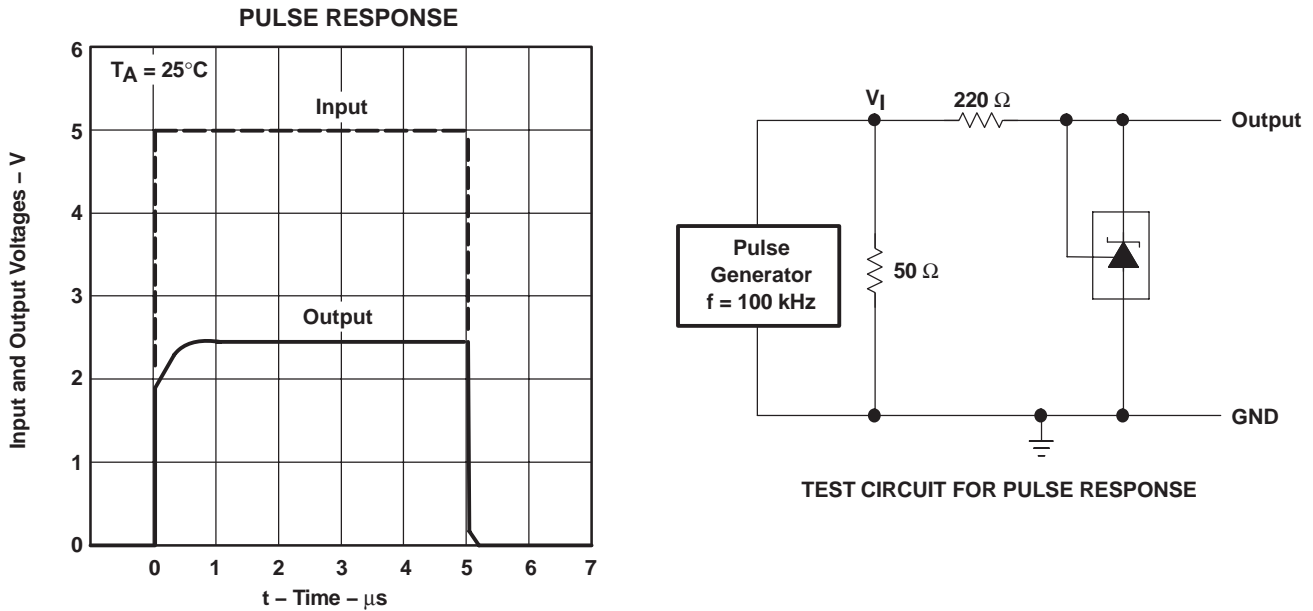
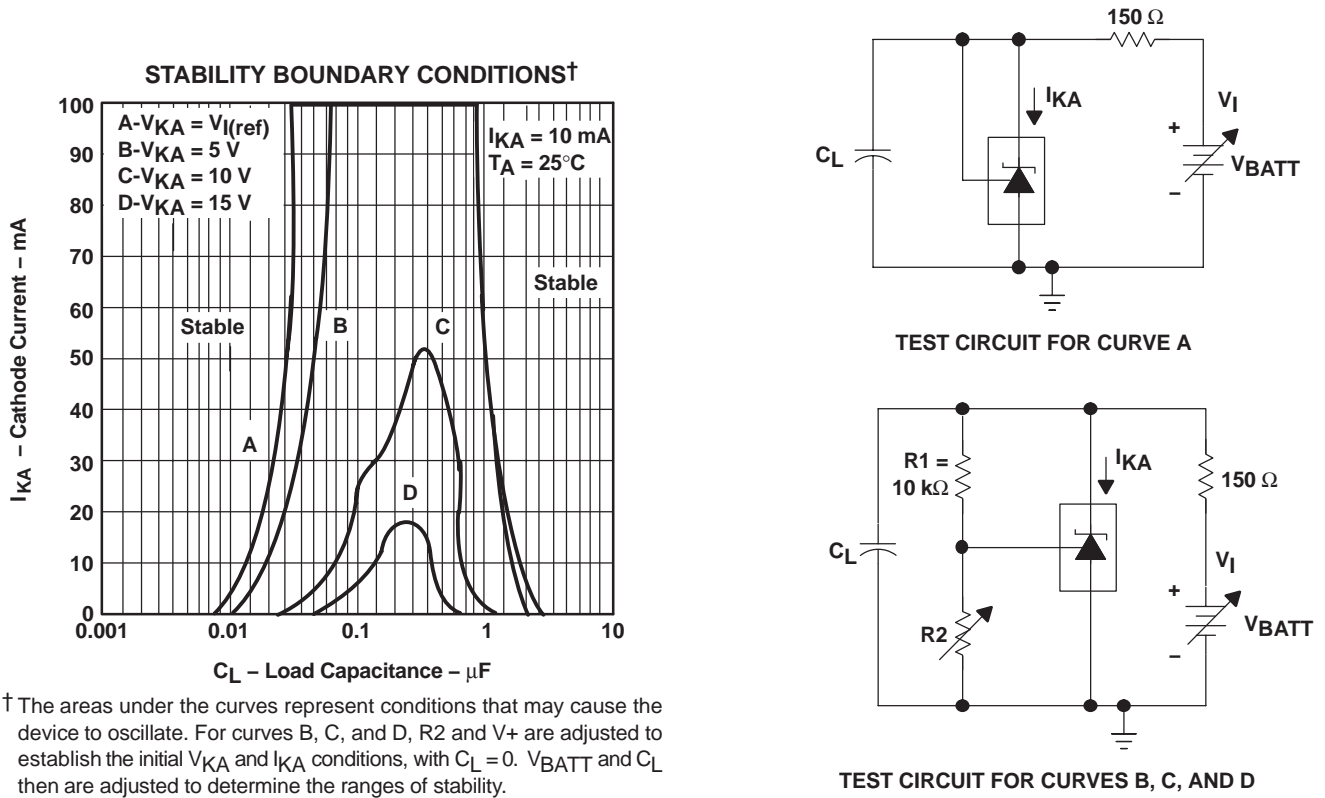

Figure 14



† The areas under the curves represent conditions that may cause the device to oscillate. For curves B, C, and D, R2 and V+ are adjusted to establish the initial V_{KA} and I_{KA} conditions, with $C_L = 0$. V_{BATT} and C_L then are adjusted to determine the ranges of stability.

Figure 15

APPLICATION INFORMATION

Table of Application Circuits

APPLICATION	FIGURE
Shunt regulator	16
Single-supply comparator with temperature-compensated threshold	17
Precision high-current series regulator	18
Output control of a three-terminal fixed regulator	19
Higher-current shunt regulator	20
Crowbar	21
Precision 5-V, 1.5-A, 0.5% regulator	22
5-V precision regulator	23
PWM converter with 0.5% reference	24
Voltage monitor	25
Delay timer	26
Precision current limiter	27
Precision constant-current sink	28

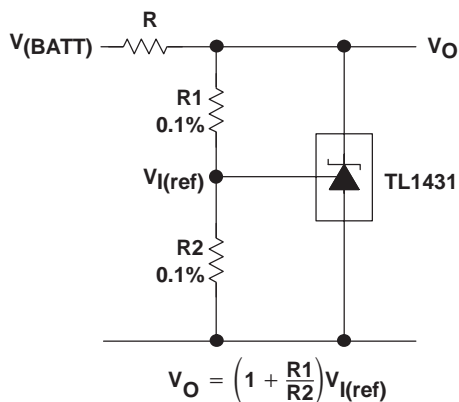

NOTE A: R should provide cathode current ≥ 1 mA to the TL1431 at minimum $V_{(BATT)}$.

Figure 16. Shunt Regulator

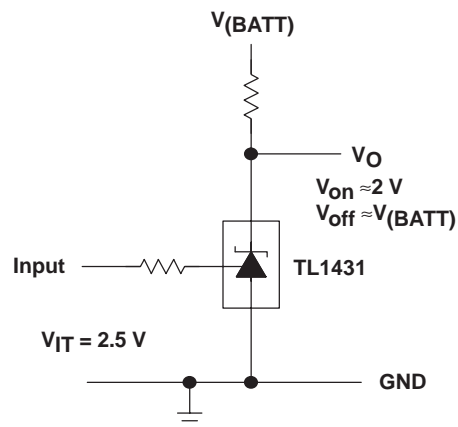
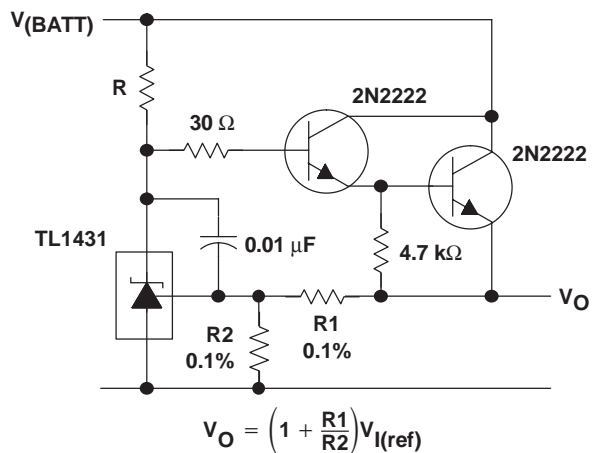

Figure 17. Single-Supply Comparator With Temperature-Compensated Threshold

TL1431-Q1 PRECISION PROGRAMMABLE REFERENCE

SLVS534B – JUNE 2004 – REVISED APRIL 2008

APPLICATION INFORMATION



NOTE A: R should provide cathode current ≥ 1 mA to the TL1431 at minimum $V_{(BATT)}$.

Figure 18. Precision High-Current Series Regulator

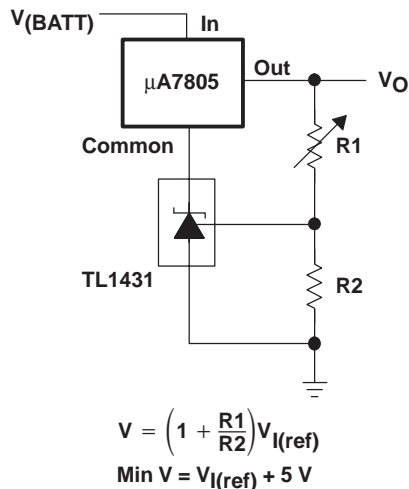

Figure 19. Output Control of a Three-Terminal Fixed Regulator

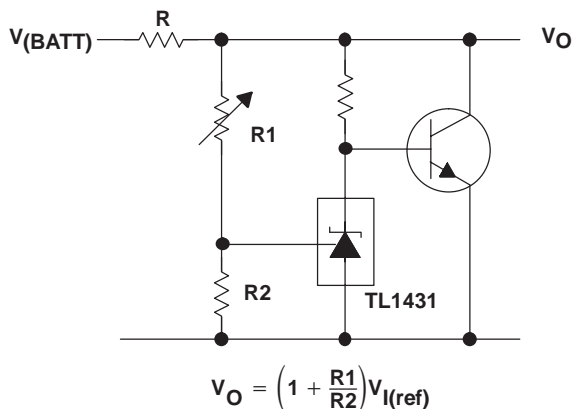
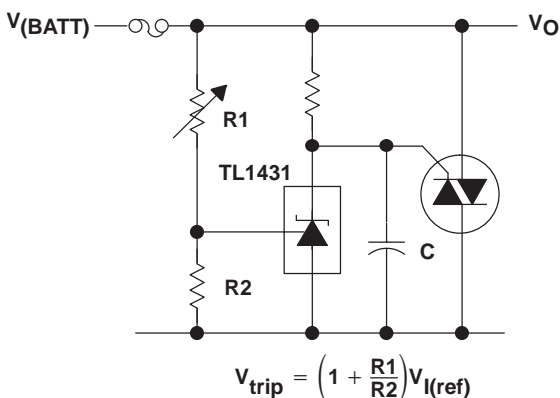

Figure 20. Higher-Current Shunt Regulator



NOTE A: Refer to the stability boundary conditions in Figure 15 to determine allowable values for C.

Figure 21. Crowbar

APPLICATION INFORMATION

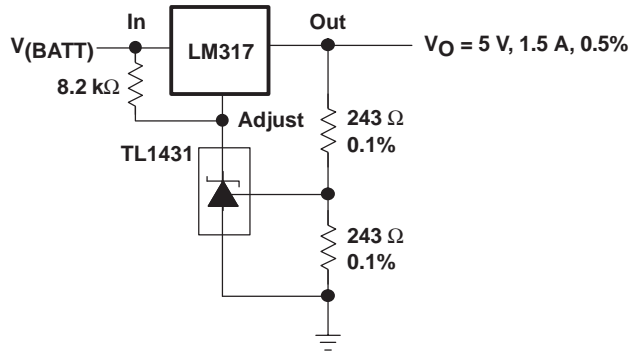
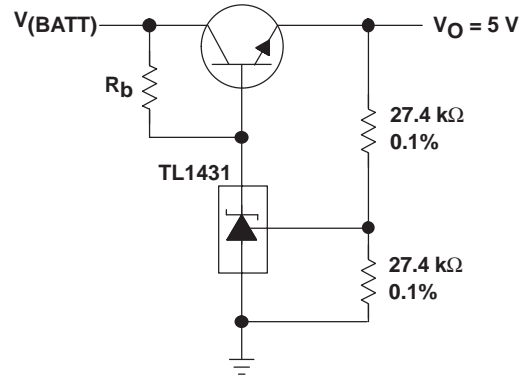

Figure 22. Precision 5-V, 1.5-A, 0.5% Regulator



NOTE A: R_b should provide cathode current ≥ 1 mA to the TL1431.

Figure 23. 5-V Precision Regulator

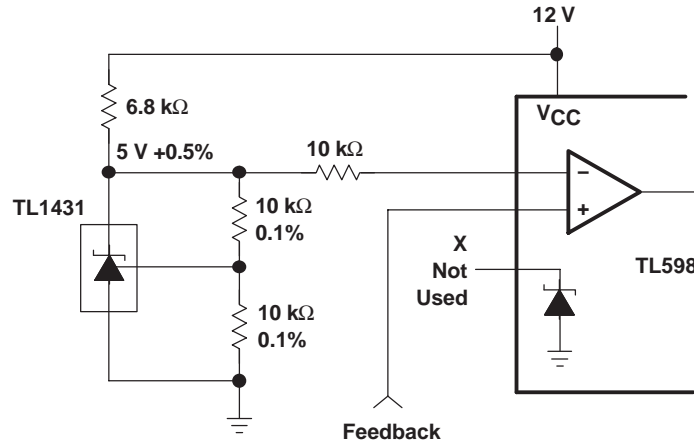
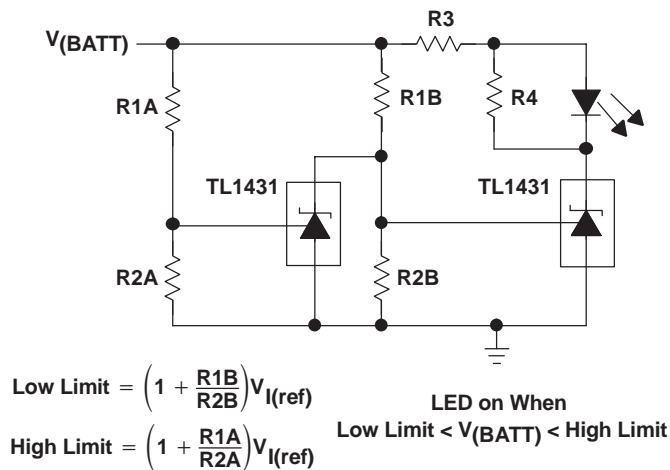

Figure 24. PWM Converter With 0.5% Reference

TL1431-Q1 PRECISION PROGRAMMABLE REFERENCE

SLVS534B – JUNE 2004 – REVISED APRIL 2008

APPLICATION INFORMATION



NOTE A: Select R3 and R4 to provide the desired LED intensity and cathode current ≥ 1 mA to the TL1431.

Figure 25. Voltage Monitor

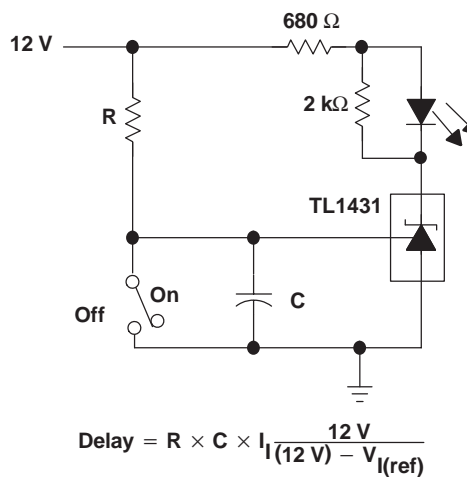

Figure 26. Delay Timer

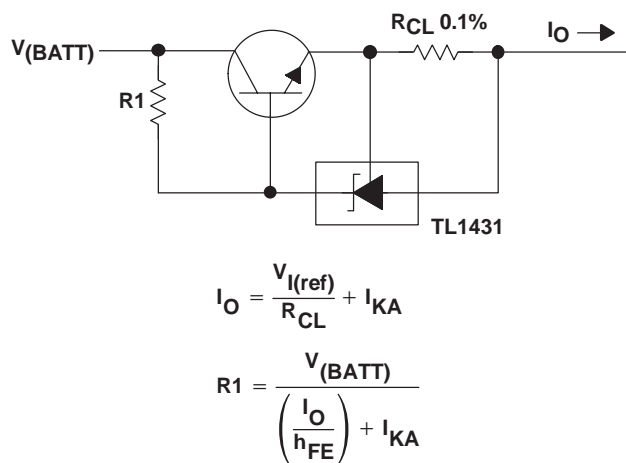

Figure 27. Precision Current Limiter

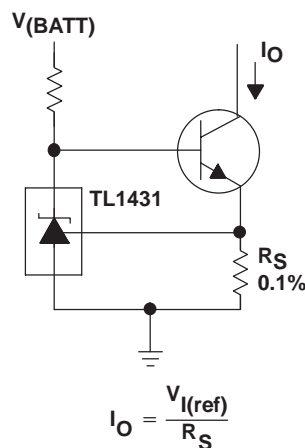

Figure 28. Precision Constant-Current Sink

PACKAGING INFORMATION

Orderable Device	Status (1)	Package Type	Package Drawing	Pins	Package Qty	Eco Plan (2)	Lead finish/ Ball material (6)	MSL Peak Temp (3)	Op Temp (°C)	Device Marking (4/5)	Samples
TL1431QDRG4Q1	ACTIVE	SOIC	D	8	2500	RoHS & Green	NIPDAU	Level-1-260C-UNLIM	-40 to 125	1431Q1	Samples
TL1431QDRQ1	ACTIVE	SOIC	D	8	2500	RoHS & Green	NIPDAU	Level-1-260C-UNLIM	-40 to 125	1431Q1	Samples

(1) The marketing status values are defined as follows:

ACTIVE: Product device recommended for new designs.

LIFEBUY: TI has announced that the device will be discontinued, and a lifetime-buy period is in effect.

NRND: Not recommended for new designs. Device is in production to support existing customers, but TI does not recommend using this part in a new design.

PREVIEW: Device has been announced but is not in production. Samples may or may not be available.

OBSELETE: TI has discontinued the production of the device.

(2) **RoHS:** TI defines "RoHS" to mean semiconductor products that are compliant with the current EU RoHS requirements for all 10 RoHS substances, including the requirement that RoHS substance do not exceed 0.1% by weight in homogeneous materials. Where designed to be soldered at high temperatures, "RoHS" products are suitable for use in specified lead-free processes. TI may reference these types of products as "Pb-Free".

RoHS Exempt: TI defines "RoHS Exempt" to mean products that contain lead but are compliant with EU RoHS pursuant to a specific EU RoHS exemption.

Green: TI defines "Green" to mean the content of Chlorine (Cl) and Bromine (Br) based flame retardants meet JS709B low halogen requirements of <=1000ppm threshold. Antimony trioxide based flame retardants must also meet the <=1000ppm threshold requirement.

(3) MSL, Peak Temp. - The Moisture Sensitivity Level rating according to the JEDEC industry standard classifications, and peak solder temperature.

(4) There may be additional marking, which relates to the logo, the lot trace code information, or the environmental category on the device.

(5) Multiple Device Markings will be inside parentheses. Only one Device Marking contained in parentheses and separated by a "~" will appear on a device. If a line is indented then it is a continuation of the previous line and the two combined represent the entire Device Marking for that device.

(6) Lead finish/Ball material - Orderable Devices may have multiple material finish options. Finish options are separated by a vertical ruled line. Lead finish/Ball material values may wrap to two lines if the finish value exceeds the maximum column width.

Important Information and Disclaimer:The information provided on this page represents TI's knowledge and belief as of the date that it is provided. TI bases its knowledge and belief on information provided by third parties, and makes no representation or warranty as to the accuracy of such information. Efforts are underway to better integrate information from third parties. TI has taken and continues to take reasonable steps to provide representative and accurate information but may not have conducted destructive testing or chemical analysis on incoming materials and chemicals. TI and TI suppliers consider certain information to be proprietary, and thus CAS numbers and other limited information may not be available for release.

In no event shall TI's liability arising out of such information exceed the total purchase price of the TI part(s) at issue in this document sold by TI to Customer on an annual basis.

OTHER QUALIFIED VERSIONS OF TL1431-Q1 :

- Catalog: [TL1431](#)
- Enhanced Product: [TL1431-EP](#)
- Military: [TL1431M](#)
- Space: [TL1431-SP](#)

NOTE: Qualified Version Definitions:

- Catalog - TI's standard catalog product
- Enhanced Product - Supports Defense, Aerospace and Medical Applications
- Military - QML certified for Military and Defense Applications
- Space - Radiation tolerant, ceramic packaging and qualified for use in Space-based application



D0008A

PACKAGE OUTLINE

SOIC - 1.75 mm max height

SMALL OUTLINE INTEGRATED CIRCUIT

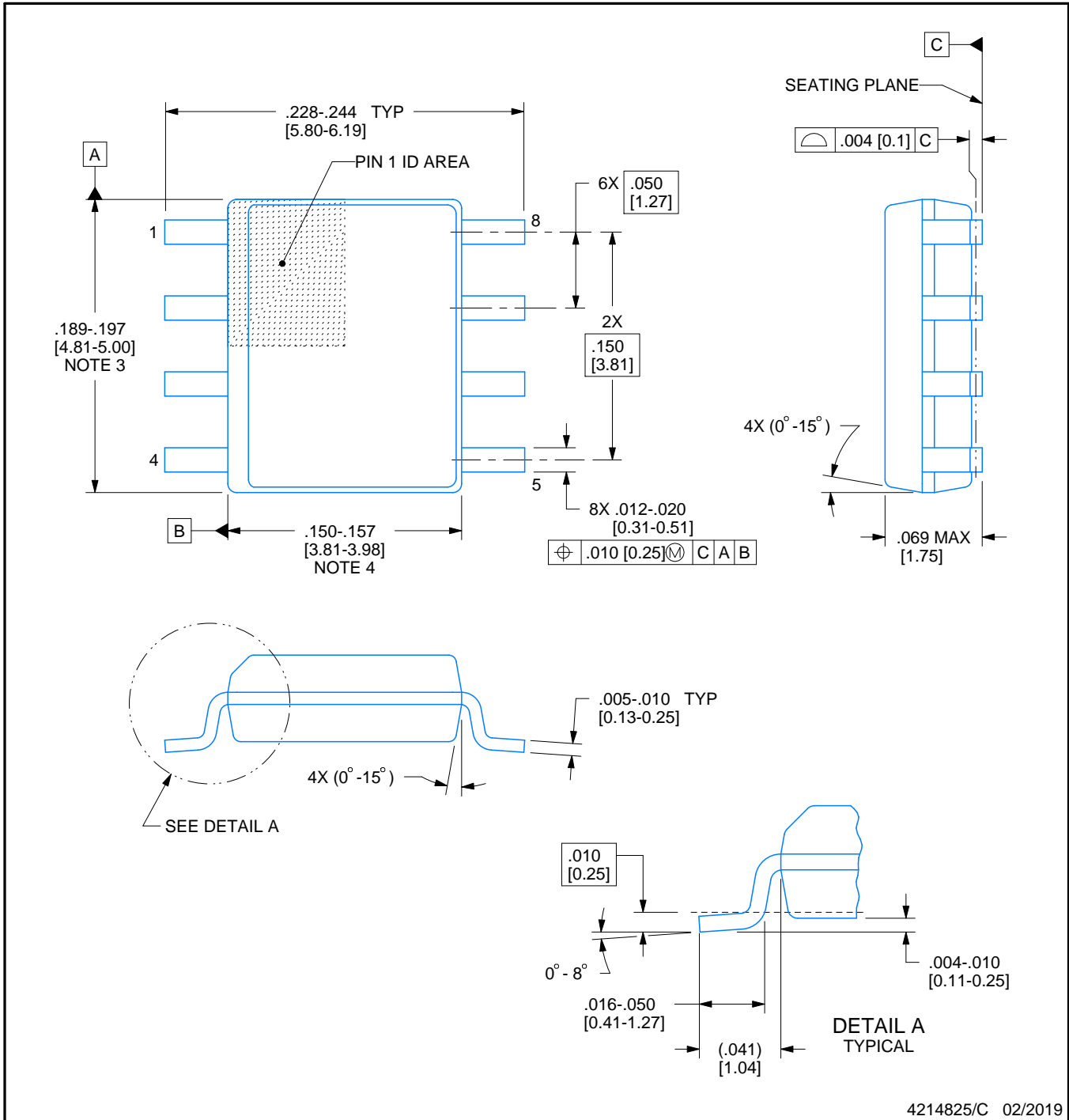

4214825/C 02/2019

NOTES:

1. Linear dimensions are in inches [millimeters]. Dimensions in parenthesis are for reference only. Controlling dimensions are in inches. Dimensioning and tolerancing per ASME Y14.5M.
2. This drawing is subject to change without notice.
3. This dimension does not include mold flash, protrusions, or gate burrs. Mold flash, protrusions, or gate burrs shall not exceed $.006$ [0.15] per side.
4. This dimension does not include interlead flash.
5. Reference JEDEC registration MS-012, variation AA.

EXAMPLE BOARD LAYOUT

D0008A

SOIC - 1.75 mm max height

SMALL OUTLINE INTEGRATED CIRCUIT



LAND PATTERN EXAMPLE
 EXPOSED METAL SHOWN
 SCALE:8X



SOLDER MASK DETAILS

4214825/C 02/2019

NOTES: (continued)

6. Publication IPC-7351 may have alternate designs.

7. Solder mask tolerances between and around signal pads can vary based on board fabrication site.

EXAMPLE STENCIL DESIGN

D0008A

SOIC - 1.75 mm max height

SMALL OUTLINE INTEGRATED CIRCUIT



SOLDER PASTE EXAMPLE
BASED ON .005 INCH [0.125 MM] THICK STENCIL
SCALE:8X

4214825/C 02/2019

NOTES: (continued)

8. Laser cutting apertures with trapezoidal walls and rounded corners may offer better paste release. IPC-7525 may have alternate design recommendations.
9. Board assembly site may have different recommendations for stencil design.

IMPORTANT NOTICE AND DISCLAIMER

TI PROVIDES TECHNICAL AND RELIABILITY DATA (INCLUDING DATASHEETS), DESIGN RESOURCES (INCLUDING REFERENCE DESIGNS), APPLICATION OR OTHER DESIGN ADVICE, WEB TOOLS, SAFETY INFORMATION, AND OTHER RESOURCES "AS IS" AND WITH ALL FAULTS, AND DISCLAIMS ALL WARRANTIES, EXPRESS AND IMPLIED, INCLUDING WITHOUT LIMITATION ANY IMPLIED WARRANTIES OF MERCHANTABILITY, FITNESS FOR A PARTICULAR PURPOSE OR NON-INFRINGEMENT OF THIRD PARTY INTELLECTUAL PROPERTY RIGHTS.

These resources are intended for skilled developers designing with TI products. You are solely responsible for (1) selecting the appropriate TI products for your application, (2) designing, validating and testing your application, and (3) ensuring your application meets applicable standards, and any other safety, security, or other requirements. These resources are subject to change without notice. TI grants you permission to use these resources only for development of an application that uses the TI products described in the resource. Other reproduction and display of these resources is prohibited. No license is granted to any other TI intellectual property right or to any third party intellectual property right. TI disclaims responsibility for, and you will fully indemnify TI and its representatives against, any claims, damages, costs, losses, and liabilities arising out of your use of these resources.

TI's products are provided subject to TI's Terms of Sale (www.ti.com/legal/termsofsale.html) or other applicable terms available either on ti.com or provided in conjunction with such TI products. TI's provision of these resources does not expand or otherwise alter TI's applicable warranties or warranty disclaimers for TI products.

Mailing Address: Texas Instruments, Post Office Box 655303, Dallas, Texas 75265
Copyright © 2020, Texas Instruments Incorporated

Looking for pricing, stock, or lifecycle information?

Click below to explore more details on WIN SOURCE:

 [View TL1431QDRQ1](#) on WIN SOURCE

 [Texas Instruments](#) Information

Optimize Your Supply Chain with WIN SOURCE Solutions

-  Global Sourcing Solution
-  Obsolete Management
-  Cost Control Management
-  Shortage Management
-  Alternative Solution
-  Excess Inventory Management