



**THE DATASHEET OF
AM26LS31MJB**



AM26LS31 Quadruple Differential Line Driver

1 Features

- Meets or exceeds the requirements of ANSI TIA/EIA-422-B and ITU
- Operates from a single 5V supply
- TTL-Compatible
- Complementary outputs
- High output impedance in power-off conditions
- Complementary output-enable inputs
- Available MIL-PRF-38535-qualified options (M): All parameters are tested unless otherwise noted. On all other products, production processing does not necessarily include testing of all parameters.

2 Applications

- Motor encoders
- Field transmitters: pressure sensors and temperature sensors
- Military and avionics imaging
- Temperature sensors or controllers using modbus

3 Description

The AM26LS31CN-E family of devices is a quadruple complementary-output line driver designed to meet the requirements of ANSI TIA/EIA-422-B and ITU (formerly CCITT) Recommendation V.11. The 3-state outputs have high-current capability for driving balanced lines such as twisted-pair or parallel-wire transmission lines, and are in the high-impedance state in the power-off condition. The enable function is common to all four drivers and offers the choice of an active-high or active-low enable (G , \bar{G}) input. Low-power Schottky circuitry reduces power consumption without sacrificing speed.

Package Information

PART NUMBER	PACKAGE ⁽¹⁾	PACKAGE SIZE ⁽²⁾
AM26LS31MFK	LCCC (20)	8.89mm × 8.89mm
AM26LS31MJ	CDIP (16)	19.6mm × 6.92mm
AM26LS31MW	CFP (16)	10.3mm × 6.73mm
AM26LS31CD	SOIC (16)	9.9mm × 3.91mm
AM26LS31CDB	SSOP (16)	6.2mm × 5.3mm
AM26LS31CN-E	PDIP (16)	19.3mm × 6.35mm
AM26LS31xNS	SO (16)	10.3mm × 5.3mm

(1) For more information, see [Section 11](#).

(2) The package size (length × width) is a nominal value and includes pins, where applicable.

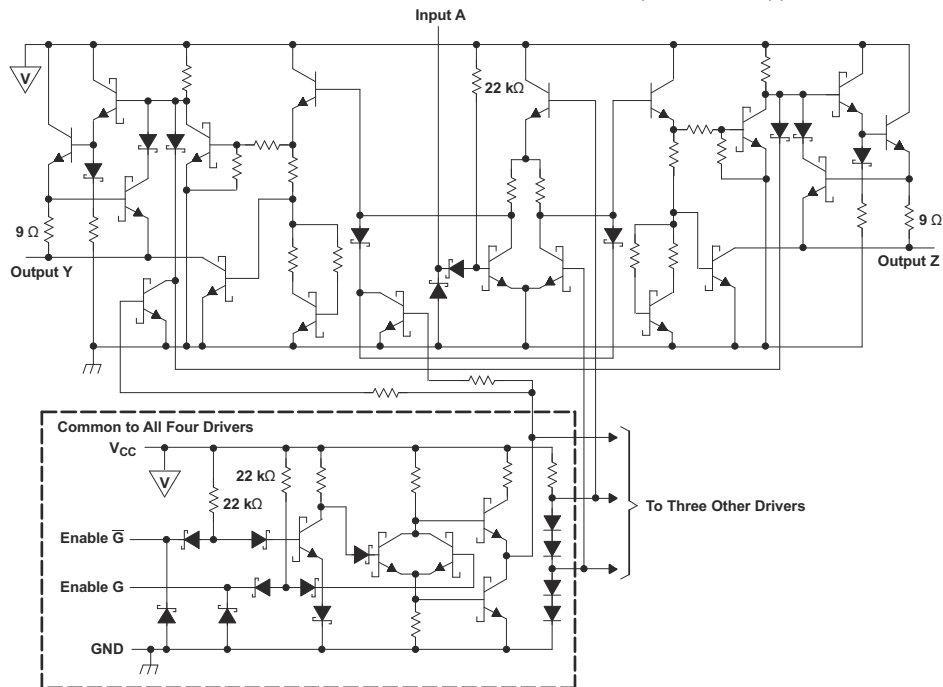

All resistor values are nominal.

Copyright © 2016, Texas Instruments Incorporated

Schematic (Each Driver)



An IMPORTANT NOTICE at the end of this data sheet addresses availability, warranty, changes, use in safety-critical applications, intellectual property matters and other important disclaimers. PRODUCTION DATA.

Table of Contents

1 Features	1	7.3 Feature Description.....	10
2 Applications	1	7.4 Device Functional Modes.....	11
3 Description	1	8 Application and Implementation	12
4 Pin Configuration and Functions	3	8.1 Application Information.....	12
5 Specifications	5	8.2 Typical Application.....	12
5.1 Absolute Maximum Ratings.....	5	8.3 Power Supply Recommendations.....	13
5.2 ESD Ratings.....	5	8.4 Layout.....	13
5.3 Recommended Operating Conditions.....	5	9 Device and Documentation Support	15
5.4 Thermal Information.....	5	9.1 Documentation Support.....	15
5.5 Electrical Characteristics.....	6	9.2 Receiving Notification of Documentation Updates....	15
5.6 Switching Characteristics – AM26LS31.....	6	9.3 Support Resources.....	15
5.7 Switching Characteristics – AM26LS31M.....	6	9.4 Trademarks.....	15
5.8 Typical Characteristics.....	7	9.5 Electrostatic Discharge Caution.....	15
6 Parameter Measurement Information	9	9.6 Glossary.....	15
7 Detailed Description	10	10 Revision History	15
7.1 Overview.....	10	11 Mechanical, Packaging, and Orderable Information	16
7.2 Functional Block Diagram.....	10		

4 Pin Configuration and Functions

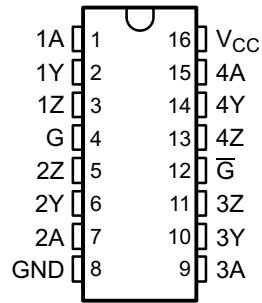

**Figure 4-1. D (SOIC), DB (SSOP), N (PDIP) , NS (SO), J (CDIP), or W (CFP) Packages
(Top View)**

Table 4-1. Pin Functions

PIN		I/O	DESCRIPTION
NAME	NO.		
1A	1	I	Logic Data Input to RS422 Driver number 1
1Y	2	O	RS-422 Data Line (Driver 1)
1Z	3	O	RS-422 Data Line (Driver 1)
G	4	I	Driver Enable (active high)
\bar{G}	12	I	Driver Enable (active Low)
2A	7	I	Logic Data Input to RS422 Driver number 2
2Y	6	O	RS-422 Data Line (Driver 2)
2Z	5	O	RS-422 Data Line (Driver 2)
3A	9	I	Logic Data Input to RS422 Driver number 3
3Y	10	O	RS-422 Data Line (Driver 3)
3Z	11	O	RS-422 Data Line (Driver 3)
4A	15	I	Logic Data Input to RS422 Driver number 4
4Y	14	O	RS-422 Data Line (Driver 4)
4Z	13	O	RS-422 Data Line (Driver 4)
VCC	16	–	Power Input. Connect to 5V Power Source.
GND	8	–	Device Ground Pin

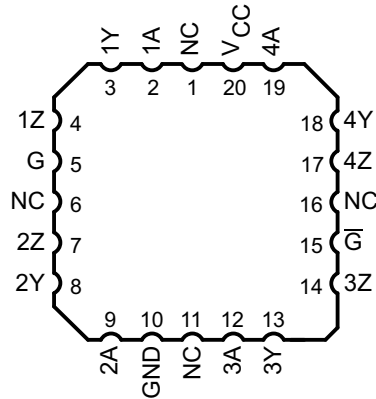

**Figure 4-2. FK (LCCC) 20-Pin Package
(Top View)**

Table 4-2. Pin Functions

PIN		I/O	DESCRIPTION
NAME	NO.		
1A	1	I	Logic Data Input to RS422 Driver number 1
1Y	2	O	RS-422 Data Line (Driver 1)
1Z	3	O	RS-422 Data Line (Driver 1)
G	4	I	Driver Enable (active high)
\bar{G}	12	I	Driver Enable (active Low)
2A	7	I	Logic Data Input to RS422 Driver number 2
2Y	6	O	RS-422 Data Line (Driver 2)
2Z	5	O	RS-422 Data Line (Driver 2)
3A	9	I	Logic Data Input to RS422 Driver number 3
3Y	10	O	RS-422 Data Line (Driver 3)
3Z	11	O	RS-422 Data Line (Driver 3)
4A	15	I	Logic Data Input to RS422 Driver number 4
4Y	14	O	RS-422 Data Line (Driver 4)
4Z	13	O	RS-422 Data Line (Driver 4)
VCC	8	I	Power Input. Connect to 5V Power Source.
GND	16	I	Device Ground Pin

5 Specifications

5.1 Absolute Maximum Ratings

over operating free-air temperature range (unless otherwise noted)⁽¹⁾

		MIN	MAX	UNIT
V _{CC}	Supply voltage ⁽²⁾		7	V
V _I	Input voltage		7	V
	Output off-state voltage		5.5	V
	Lead temperature 1,6 mm (1/16 in) from case for 10 s		260	°C
	Lead temperature 1,6 mm (1/16 in) from case for 60 s	J package	300	°C
T _{stg}	Storage temperature	-65	150	°C

- (1) Stresses beyond those listed under *Absolute Maximum Ratings* may cause permanent damage to the device. These are stress ratings only, and functional operation of the device at these or any other conditions beyond those indicated under *Recommended Operating Conditions* is not implied. Exposure to absolute-maximum-rated conditions for extended periods may affect device reliability.
- (2) All voltage values, except differential output voltage V_{OD}, are with respect to network GND.

5.2 ESD Ratings

		VALUE	UNIT
V _(ESD)	Electrostatic discharge	Human-body model (HBM), per ANSI/ESDA/JEDEC JS-001 ⁽¹⁾	±2000
		Charged-device model (CDM), per JEDEC specification JESD22-C101 ⁽²⁾	±1000

- (1) JEDEC document JEP155 states that 500-V HBM allows safe manufacturing with a standard ESD control process.
- (2) JEDEC document JEP157 states that 250-V CDM allows safe manufacturing with a standard ESD control process.

5.3 Recommended Operating Conditions

		MIN	NOM	MAX	UNIT	
V _{CC}	Supply voltage	AM26LS31C	4.75	5	5.25	V
		AM26LS31M	4.5	5	5.5	
V _{IH}	High-level input voltage	2			V	
V _{IL}	Low-level input voltage			0.8	V	
I _{OH}	High-level output current			-20	mA	
I _{OL}	Low-level output current			20	mA	
T _A	Operating free-air temperature	AM26LS31C	0	70	°C	
		AM26LS31I	-40	85		
		AM26LS31M	-55	125		

5.4 Thermal Information

THERMAL METRIC ⁽¹⁾		AM26LS31x				UNIT
		D (SOIC)	DB (SSOP)	N (PDIP)	NS (SO)	
		16 PINS	16 PINS	16 PINS	16 PINS	
R _{θJA}	Junction-to-ambient thermal resistance ⁽²⁾	84.6	82	60.6	88.5	°C/W
R _{θJC(top)}	Junction-to-case (top) thermal resistance	43.5	–	48.1	46.2	°C/W
R _{θJB}	Junction-to-board thermal resistance	43.2	–	40.6	50.7	°C/W
ψ _{JT}	Junction-to-top characterization parameter	10.4	–	27.5	13.5	°C/W
ψ _{JB}	Junction-to-board characterization parameter	42.8	–	40.3	50.3	°C/W

- (1) For more information about traditional and new thermal metrics, see the [Semiconductor and IC Package Thermal Metrics](#) application report.
- (2) The package thermal impedance is calculated in accordance with JESD 51-7.

5.5 Electrical Characteristics

over operating free-air temperature range (unless otherwise noted)⁽¹⁾

PARAMETER		TEST CONDITIONS	MIN	TYP ⁽²⁾	MAX	UNIT
V _{IK}	Input clamp voltage	V _{CC} = MIN, I _I = -18mA			-1.5	V
V _{OH}	High-level output voltage	V _{CC} = MIN, I _{OH} = -20mA	2.5			V
V _{OL}	Low-level output voltage	V _{CC} = MIN, I _{OL} = 20mA			0.5	V
I _{OZ}	Off-state (high-impedance-state) output current	V _{CC} = MIN,	V _O = 0.5V		-20	μA
			V _O = 2.5V		20	
I _I	Input current at maximum input voltage	V _{CC} = MAX, V _I = 7V			0.1	mA
I _{IH}	High-level input current	V _{CC} = MAX, V _I = 2.7V			20	μA
I _{IL}	Low-level input current	V _{CC} = MAX, V _I = 0.4V			-0.36	mA
I _{OS}	Short-circuit output current ⁽³⁾	V _{CC} = MAX	-30		-150	mA
I _{CC}	Supply current	V _{CC} = MAX, all outputs disabled		32	80	mA

(1) For C-suffix devices, V_{CC} min = 4.75V and V_{CC} max = 5.25V. For M-suffix devices, V_{CC} min = 4.5V and V_{CC} max = 5.5V.

(2) All typical values are at V_{CC} = 5V and T_A = 25°C.

(3) Not more than one output should be shorted at a time, and duration of the short circuit should not exceed one second.

5.6 Switching Characteristics – AM26LS31

T_A = 25°C, V_{CC} = 5V (see Figure 6-1)

PARAMETER		TEST CONDITIONS	MIN	TYP	MAX	UNIT
t _{PLH}	Propagation delay time, low- to high-level output	C _L = 30pF, S1 and S2 open		14	20	ns
t _{PHL}	Propagation delay time, high- to low-level output			14	20	
t _{PZH}	Output enable time to high level	C _L = 30pF	R _L = 75Ω		25	ns
t _{PZL}	Output enable time to low level		R _L = 180Ω		37	
t _{PHZ}	Output disable time from high level	C _L = 10pF, S1 and S2 closed		21	30	ns
t _{PLZ}	Output disable time from low level			23	35	
t _{SKREW}	Output-to-output skew	C _L = 30pF, S1 and S2 open		1	6	ns

5.7 Switching Characteristics – AM26LS31M

T_A = 25°C, V_{CC} = 5V (see Figure 6-1)

PARAMETER		TEST CONDITIONS	MIN	MAX	UNIT	
t _{PLH}	Propagation delay time, low- to high-level output	C _L = 30pF, S1 and S2 open		30	ns	
t _{PHL}	Propagation delay time, high- to low-level output			30		
t _{PZH}	Output enable time to high level	C _L = 30pF	R _L = 75Ω		60	ns
t _{PZL}	Output enable time to low level		R _L = 180Ω		68	
t _{PHZ}	Output disable time from high level	C _L = 10pF, S1 and S2 closed		45	ns	
t _{PLZ}	Output disable time from low level			53		
t _{SKREW}	Output-to-output skew	C _L = 30pF, S1 and S2 open		9	ns	

5.8 Typical Characteristics

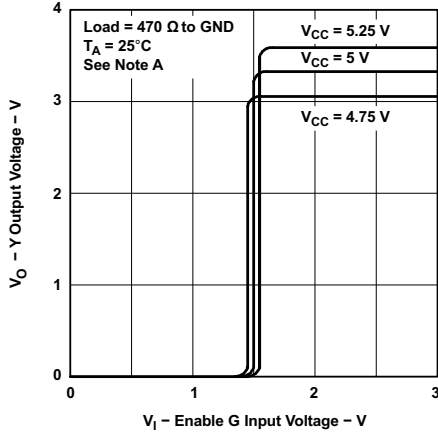

A. The A input is connected to V_{CC} during testing of the Y outputs and to ground during testing of the Z outputs.

Figure 5-1. Output Voltage vs Enable G Input Voltage

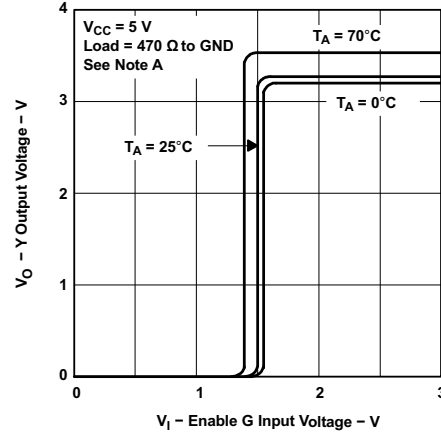

A. The A input is connected to V_{CC} during testing of the Y outputs and to ground during testing of the Z outputs.

Figure 5-2. Output Voltage vs Enable G Input Voltage

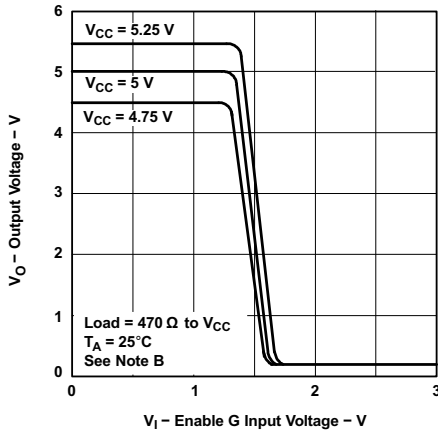

B. The A input is connected to ground during testing of the Y outputs and to V_{CC} during testing of the Z outputs.

Figure 5-3. Output Voltage vs Enable G Input Voltage

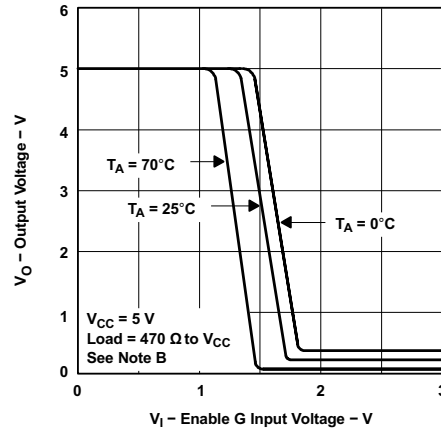

B. The A input is connected to ground during testing of the Y outputs and to V_{CC} during testing of the Z outputs.

Figure 5-4. Output Voltage vs Enable G Input Voltage

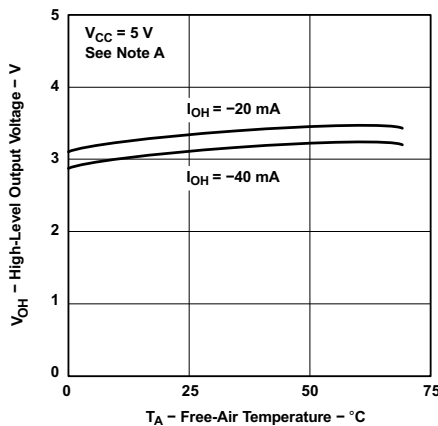

A. The A input is connected to V_{CC} during testing of the Y outputs and to ground during testing of the Z outputs.

Figure 5-5. High-Level Output Voltage vs Free-Air Temperature

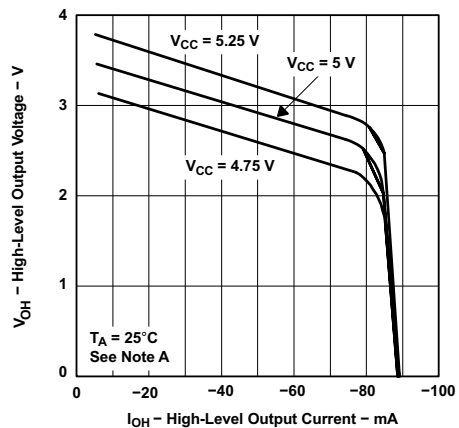

A. The A input is connected to V_{CC} during testing of the Y outputs and to ground during testing of the Z outputs.

Figure 5-6. High-Level Output Voltage vs High-Level Output Current

5.8 Typical Characteristics (continued)

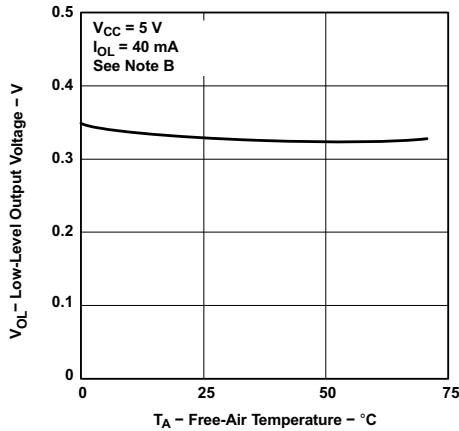

B. The A input is connected to ground during testing of the Y outputs and to V_{CC} during testing of the Z outputs.

Figure 5-7. Low-Level Output Voltage vs Free-Air Temperature

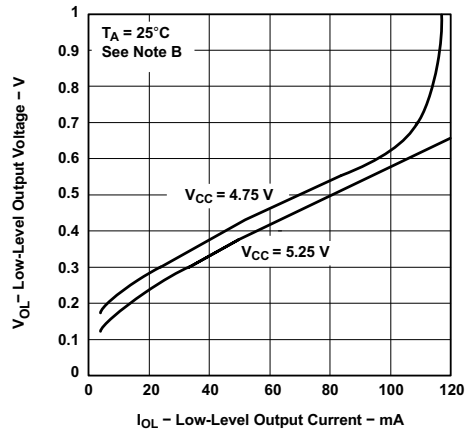

B. The A input is connected to ground during testing of the Y outputs and to V_{CC} during testing of the Z outputs.

Figure 5-8. Low-Level Output Voltage vs Low-Level Output Current

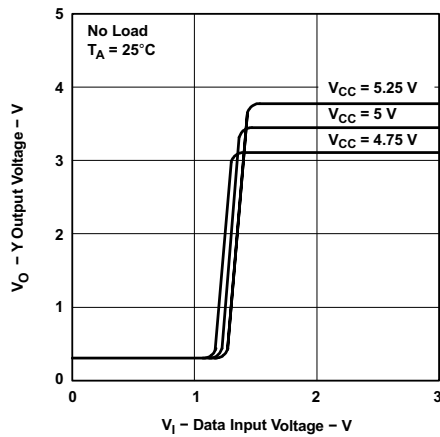

Figure 5-9. Y Output Voltage vs Data Input Voltage

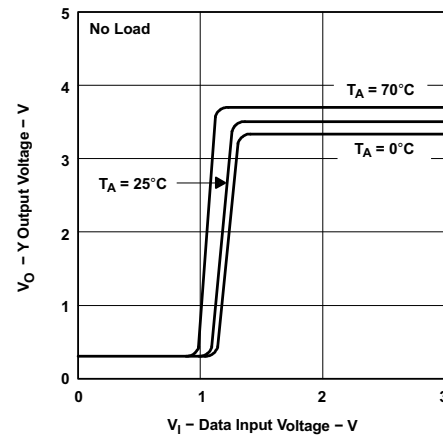
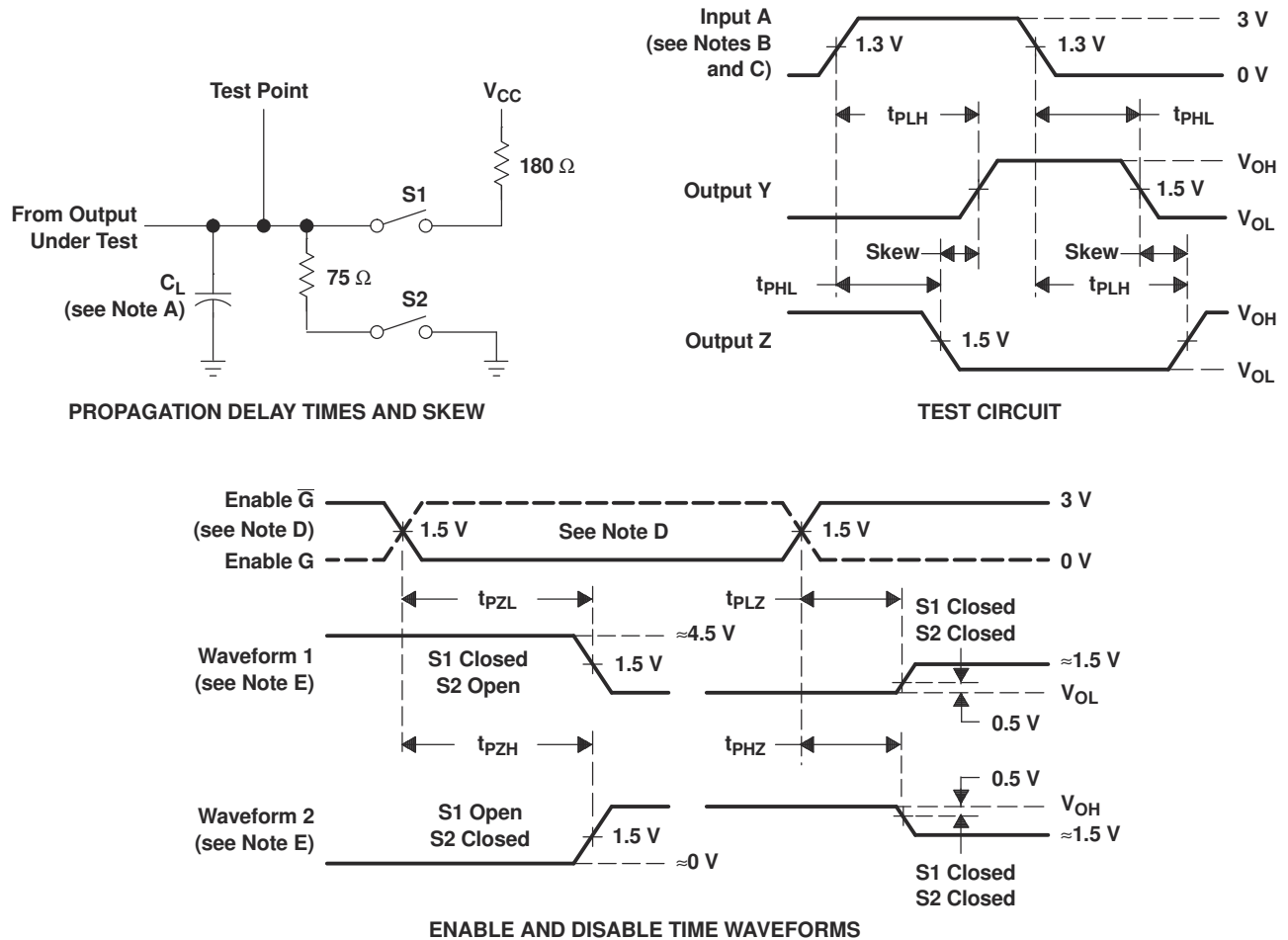

Figure 5-10. Y Output Voltage vs Data Input Voltage

6 Parameter Measurement Information



- NOTES:
- C_L includes probe and jig capacitance.
 - All input pulses are supplied by generators having the following characteristics: $PRR \leq 1$ MHz, $Z_O \approx 50 \Omega$, $t_r \leq 15$ ns, $t_f \leq 6$ ns.
 - When measuring propagation delay times and skew, switches S1 and S2 are open.
 - Each enable is tested separately.
 - Waveform 1 is for an output with internal conditions such that the output is low, except when disabled by the output control. Waveform 2 is for an output with internal conditions such that the output is high, except when disabled by the output control.

Figure 6-1. Test Circuit and Voltage Waveforms

7 Detailed Description

7.1 Overview

The AM26LS31x CN-E differential bus transmitter is a monolithic integrated circuit designed for unidirectional data communication on transmission lines. It is designed for balanced transmission lines and meets ANSI Standard EIA/TIA-422-B and ITU Recommendation V.11.

The AM26LS31x CN-E has a four 3-state differential line drivers that operate from a single 5V power supply. The driver also integrates active-high and active-low enables for precise device control.

The driver is designed to handle loads of a minimum of $\pm 30\text{mA}$ of sink or source current. The driver features positive- and negative-current limiting for protection from line fault conditions.

7.2 Functional Block Diagram

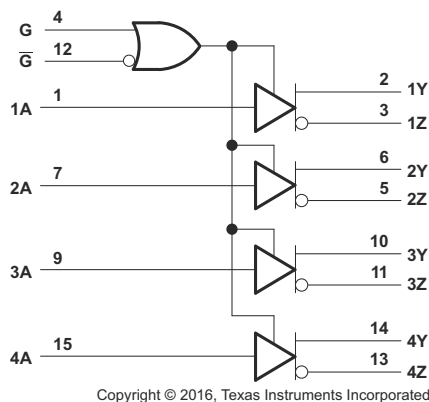

7.3 Feature Description

7.3.1 Complementary Output-Enable Inputs

The AM26LS31x can be configured using the G and \bar{G} logic inputs to control transmitter outputs. Setting either G to a logic HIGH or \bar{G} to a logic LOW enables the transmitter outputs. If G is set to logic LOW and \bar{G} is set to logic HIGH, the transmitter outputs are disabled. See [Table 7-1](#) for a complete truth table.

7.3.2 High Output Impedance in Power-Off Conditions

When the AM26LS31x transmitter outputs are disabled using G and \bar{G} , the outputs are set to a high impedance state.

7.3.3 Complementary Outputs

The AM26LS31x is the driver half of a pair of devices, with the AM26LS32 being the complementary receiver. TI recommends using these devices together for optimal performance, but any RS-422 compliant receive must ensure proper RS-422 communication and logic level translation.

7.4 Device Functional Modes

Table 7-1 lists the functional modes of the AM26LS31CN-E.

**Table 7-1. Function Table⁽¹⁾
(Each Driver)**

INPUT A	ENABLES		OUTPUTS	
	G	\bar{G}	Y	Z
H	H	X	H	L
L	H	X	L	H
H	X	L	H	L
L	X	L	L	H
X	L	H	Z	Z

- (1) H = high level, L = low level,
X = irrelevant,
Z = high impedance (off)

8 Application and Implementation

Note

Information in the following applications sections is not part of the TI component specification, and TI does not warrant its accuracy or completeness. TI's customers are responsible for determining suitability of components for their purposes, as well as validating and testing their design implementation to confirm system functionality.

8.1 Application Information

When designing a system that uses drivers, receivers, and transceivers that comply with RS-422 or RS-485, proper cable termination is essential for highly reliable applications with reduced reflections in the transmission line. Because RS-422 allows only one driver on the bus, if termination is used, it is placed only at the end of the cable near the last receiver. In general, RS-485 requires termination at both ends of the cable. Factors to consider when determining the type of termination usually are performance requirements of the application and the ever-present factor, cost. The different types of termination techniques discussed are unterminated lines, parallel termination, AC termination, and multipoint termination. Laboratory waveforms for each termination technique (except multipoint termination) illustrate the usefulness and robustness of RS-422 (and, indirectly, RS-485). Similar results can be obtained if 485-compliant devices and termination techniques are used. For laboratory experiments, 100 feet of 100Ω, 24-AWG, twisted-pair cable (Bertek) was used. A single driver and receiver, TI AM26LS31CN-E and AM26LS32C, respectively, were tested at room temperature with a 5V supply voltage. Two plots per termination technique are shown. In each plot, the top waveform is the driver input and the bottom waveform is the receiver output. To show voltage waveforms related to transmission-line reflections, the first plot shows output waveforms from the driver at the start of the cable; the second plot shows input waveforms to the receiver at the far end of the cable.

8.2 Typical Application

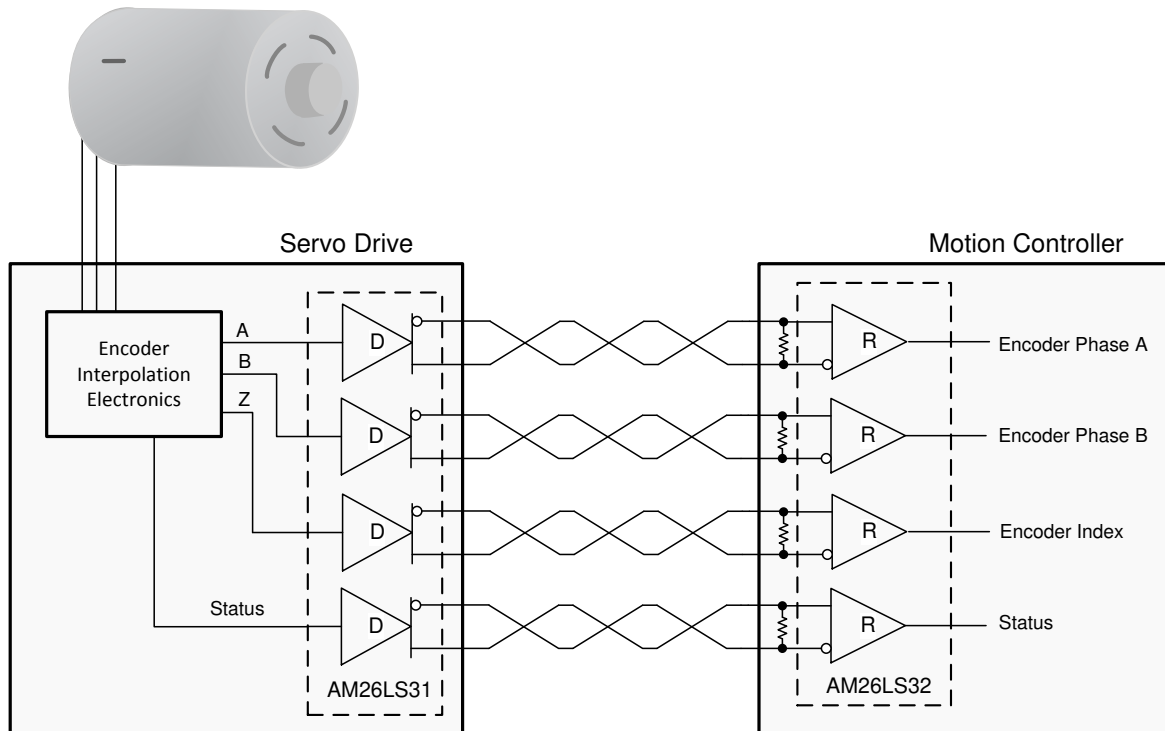

Copyright © 2016, Texas Instruments Incorporated

Figure 8-1. Encoder Application

8.2.1 Design Requirements

This example requires the following:

- 5V power source
- RS-485 bus operating at 10Mbps or less
- Connector that makes sure the correct polarity for port pins

8.2.2 Detailed Design Procedure

Place the device close to bus connector to keep traces (stub) short to prevent adding reflections to the bus line.

If desired, add external fail-safe biasing to ensure 200mV on the A-B port, if the drive is in high impedance state (see [Fail-safe in RS-485 data buses](#)).

8.2.3 Application Curve

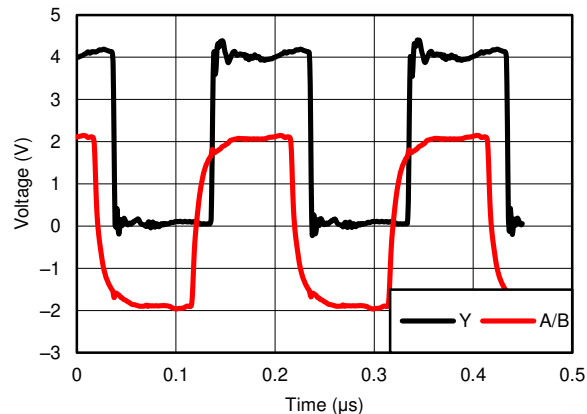

Figure 8-2. Differential 120-Ω Terminated Output Waveforms (Cat 5E Cable)

8.3 Power Supply Recommendations

Place a 0.1μF bypass capacitors close to the power-supply pins to reduce errors coupling in from noisy or high impedance power supplies.

8.4 Layout

8.4.1 Layout Guidelines

For best operational performance of the device, use good PCB layout practices, including:

- Noise can often propagate into analog circuitry through the power supply of the circuit. Bypass capacitors are used to reduce the coupled noise by providing low impedance power sources local to the analog circuitry.
 - Connect low-ESR, 0.1μF ceramic bypass capacitors between each supply pin and ground, placed as close to the device as possible. A single bypass capacitor from V+ to ground is applicable for single-supply applications.
- Separate grounding for analog and digital portions of circuitry is one of the simplest and most-effective methods of noise suppression. One or more layers on multilayer PCBs are usually devoted to ground planes. A ground plane helps distribute heat and reduces EMI noise pickup. Make sure to physically separate digital and analog grounds, paying attention to the flow of the ground current.
- To reduce parasitic coupling, run the input traces as far away from the supply or output traces as possible. If it is not possible to keep them separate, it is much better to cross the sensitive trace perpendicular as opposed to in parallel with the noisy trace.
- Place the external components as close to the device as possible. Keeping RF and RG close to the inverting input minimizes parasitic capacitance.
- Keep the length of input traces as short as possible. Always remember that the input traces are the most sensitive part of the circuit.

8.4.2 Layout Example

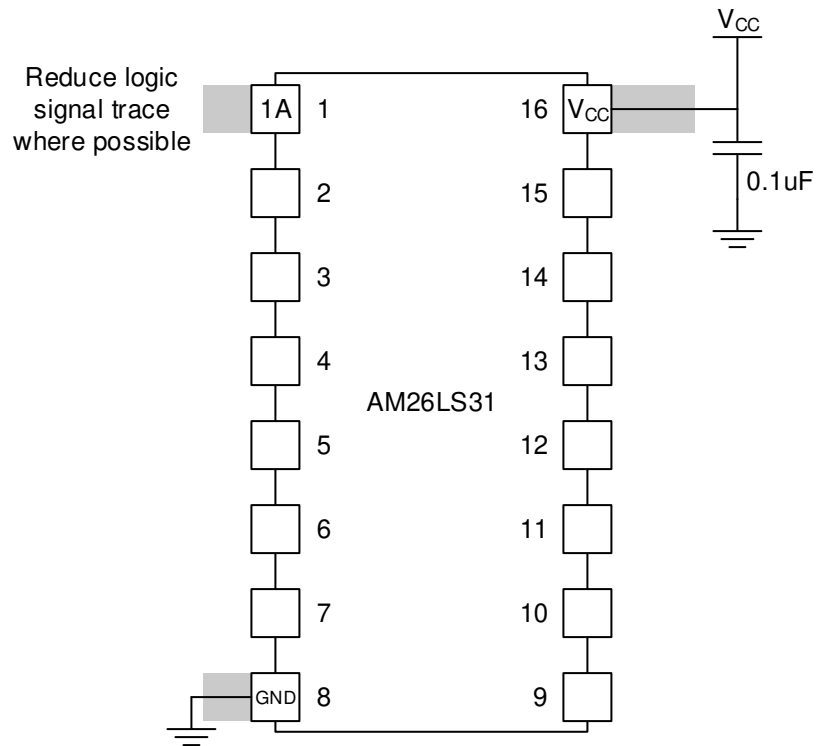

Figure 8-3. Layout Recommendation

9 Device and Documentation Support

9.1 Documentation Support

9.1.1 Related Documentation

For related documentation, see the following:

[Failsafe in RS-485 data buses \(SLYT080\)](#)

9.2 Receiving Notification of Documentation Updates

To receive notification of documentation updates, navigate to the device product folder on [ti.com](#). Click on *Notifications* to register and receive a weekly digest of any product information that has changed. For change details, review the revision history included in any revised document.

9.3 Support Resources

[TI E2E™ support forums](#) are an engineer's go-to source for fast, verified answers and design help — straight from the experts. Search existing answers or ask your own question to get the quick design help you need.

Linked content is provided "AS IS" by the respective contributors. They do not constitute TI specifications and do not necessarily reflect TI's views; see TI's [Terms of Use](#).

9.4 Trademarks

TI E2E™ is a trademark of Texas Instruments.
All trademarks are the property of their respective owners.

9.5 Electrostatic Discharge Caution



This integrated circuit can be damaged by ESD. Texas Instruments recommends that all integrated circuits be handled with appropriate precautions. Failure to observe proper handling and installation procedures can cause damage.

ESD damage can range from subtle performance degradation to complete device failure. Precision integrated circuits may be more susceptible to damage because very small parametric changes could cause the device not to meet its published specifications.

9.6 Glossary

[TI Glossary](#) This glossary lists and explains terms, acronyms, and definitions.

10 Revision History

NOTE: Page numbers for previous revisions may differ from page numbers in the current version.

Changes from Revision L (October 2018) to Revision M (March 2024) **Page**

- Changed the Device Information table to the *Package Information* table..... [1](#)
- Changed the *Thermal Information* table..... [5](#)

Changes from Revision K (July 2016) to Revision L (October 2018) **Page**

- Changed VCC pin number From: 8 To: 16 in the *Pin Functions* table [3](#)
- Changed GND pin number From: 16 To: 8 in the *Pin Functions* table [3](#)

Changes from Revision J (January 2014) to Revision K (February 2014) Page

- Added *Applications* section, the *Device Information* table, *ESD Ratings* table, *Feature Description* section, *Device Functional Modes*, *Application and Implementation* section, *Power Supply Recommendations* section, *Layout* section, *Device and Documentation Support* section, and *Mechanical, Packaging, and Orderable Information* section..... **1**
 - Split up *Switching Characteristics* table into two tables specified for each part..... **6**
-

Changes from Revision I (February 2006) to Revision J (January 2014) Page

- Updated document to new TI data sheet format - no specification changes..... **1**
 - Deleted *Ordering Information* table..... **1**
 - Updated Features..... **1**
-

11 Mechanical, Packaging, and Orderable Information

The following pages include mechanical packaging and orderable information. This information is the most current data available for the designated devices. This data is subject to change without notice and revision of this document. For browser based versions of this data sheet, refer to the left hand navigation.

PACKAGING INFORMATION

Orderable Device	Status (1)	Package Type	Package Drawing	Pins	Package Qty	Eco Plan (2)	Lead finish/ Ball material (6)	MSL Peak Temp (3)	Op Temp (°C)	Device Marking (4/5)	Samples
5962-7802301M2A	ACTIVE	LCCC	FK	20	55	Non-RoHS & Green	SNPB	N / A for Pkg Type	-55 to 125	5962- 7802301M2A AM26LS31 MFKB	Samples
5962-7802301MEA	ACTIVE	CDIP	J	16	25	Non-RoHS & Green	SNPB	N / A for Pkg Type	-55 to 125	5962-7802301ME A AM26LS31MJB	Samples
5962-7802301MFA	ACTIVE	CFP	W	16	25	Non-RoHS & Green	SNPB	N / A for Pkg Type	-55 to 125	5962-7802301MF A AM26LS31MWB	Samples
5962-7802301Q2A	ACTIVE	LCCC	FK	20	55	Non-RoHS & Green	SNPB	N / A for Pkg Type		5962- 7802301Q2A AM26LS31M	Samples
AM26LS31CDBR	ACTIVE	SSOP	DB	16	2000	RoHS & Green	NIPDAU	Level-1-260C-UNLIM	0 to 70	SA31C	Samples
AM26LS31CDR	ACTIVE	SOIC	D	16	2500	RoHS & Green	NIPDAU	Level-1-260C-UNLIM	0 to 70	AM26LS31C	Samples
AM26LS31CN	ACTIVE	PDIP	N	16	25	RoHS & Green	NIPDAU	N / A for Pkg Type	0 to 70	AM26LS31CN	Samples
AM26LS31CNSR	ACTIVE	SO	NS	16	2000	RoHS & Green	NIPDAU	Level-1-260C-UNLIM	0 to 70	26LS31	Samples
AM26LS31INSR	ACTIVE	SO	NS	16	2000	RoHS & Green	NIPDAU	Level-1-260C-UNLIM	-40 to 85	26LS31	Samples
AM26LS31MFKB	ACTIVE	LCCC	FK	20	55	Non-RoHS & Green	SNPB	N / A for Pkg Type	-55 to 125	5962- 7802301M2A AM26LS31 MFKB	Samples
AM26LS31MJB	ACTIVE	CDIP	J	16	25	Non-RoHS & Green	SNPB	N / A for Pkg Type	-55 to 125	5962-7802301ME A AM26LS31MJB	Samples
AM26LS31MWB	ACTIVE	CFP	W	16	25	Non-RoHS & Green	SNPB	N / A for Pkg Type	-55 to 125	5962-7802301MF A AM26LS31MWB	Samples

(1) The marketing status values are defined as follows:

ACTIVE: Product device recommended for new designs.

LIFEBUY: TI has announced that the device will be discontinued, and a lifetime-buy period is in effect.

NRND: Not recommended for new designs. Device is in production to support existing customers, but TI does not recommend using this part in a new design.

PREVIEW: Device has been announced but is not in production. Samples may or may not be available.

OBSOLETE: TI has discontinued the production of the device.

⁽²⁾ **RoHS:** TI defines "RoHS" to mean semiconductor products that are compliant with the current EU RoHS requirements for all 10 RoHS substances, including the requirement that RoHS substance do not exceed 0.1% by weight in homogeneous materials. Where designed to be soldered at high temperatures, "RoHS" products are suitable for use in specified lead-free processes. TI may reference these types of products as "Pb-Free".

RoHS Exempt: TI defines "RoHS Exempt" to mean products that contain lead but are compliant with EU RoHS pursuant to a specific EU RoHS exemption.

Green: TI defines "Green" to mean the content of Chlorine (Cl) and Bromine (Br) based flame retardants meet JS709B low halogen requirements of ≤ 1000 ppm threshold. Antimony trioxide based flame retardants must also meet the ≤ 1000 ppm threshold requirement.

⁽³⁾ MSL, Peak Temp. - The Moisture Sensitivity Level rating according to the JEDEC industry standard classifications, and peak solder temperature.

⁽⁴⁾ There may be additional marking, which relates to the logo, the lot trace code information, or the environmental category on the device.

⁽⁵⁾ Multiple Device Markings will be inside parentheses. Only one Device Marking contained in parentheses and separated by a "~" will appear on a device. If a line is indented then it is a continuation of the previous line and the two combined represent the entire Device Marking for that device.

⁽⁶⁾ Lead finish/Ball material - Orderable Devices may have multiple material finish options. Finish options are separated by a vertical ruled line. Lead finish/Ball material values may wrap to two lines if the finish value exceeds the maximum column width.

Important Information and Disclaimer: The information provided on this page represents TI's knowledge and belief as of the date that it is provided. TI bases its knowledge and belief on information provided by third parties, and makes no representation or warranty as to the accuracy of such information. Efforts are underway to better integrate information from third parties. TI has taken and continues to take reasonable steps to provide representative and accurate information but may not have conducted destructive testing or chemical analysis on incoming materials and chemicals. TI and TI suppliers consider certain information to be proprietary, and thus CAS numbers and other limited information may not be available for release.

In no event shall TI's liability arising out of such information exceed the total purchase price of the TI part(s) at issue in this document sold by TI to Customer on an annual basis.

OTHER QUALIFIED VERSIONS OF AM26LS31, AM26LS31M :

- Catalog : [AM26LS31](#)
- Military : [AM26LS31M](#)

NOTE: Qualified Version Definitions:

- Catalog - TI's standard catalog product

- Military - QML certified for Military and Defense Applications

TAPE AND REEL INFORMATION

QUADRANT ASSIGNMENTS FOR PIN 1 ORIENTATION IN TAPE



*All dimensions are nominal

Device	Package Type	Package Drawing	Pins	SPQ	Reel Diameter (mm)	Reel Width W1 (mm)	A0 (mm)	B0 (mm)	K0 (mm)	P1 (mm)	W (mm)	Pin1 Quadrant
AM26LS31CDBR	SSOP	DB	16	2000	330.0	16.4	8.35	6.6	2.4	12.0	16.0	Q1
AM26LS31CDR	SOIC	D	16	2500	330.0	16.4	6.5	10.3	2.1	8.0	16.0	Q1
AM26LS31CDR	SOIC	D	16	2500	330.0	16.4	6.5	10.3	2.1	8.0	16.0	Q1
AM26LS31CDRG4	SOIC	D	16	2500	330.0	16.4	6.5	10.3	2.1	8.0	16.0	Q1
AM26LS31CDRG4	SOIC	D	16	2500	330.0	16.4	6.5	10.3	2.1	8.0	16.0	Q1
AM26LS31CNSR	SO	NS	16	2000	330.0	16.4	8.2	10.5	2.5	12.0	16.0	Q1
AM26LS31INSR	SO	NS	16	2000	330.0	16.4	8.2	10.5	2.5	12.0	16.0	Q1

TAPE AND REEL BOX DIMENSIONS

*All dimensions are nominal

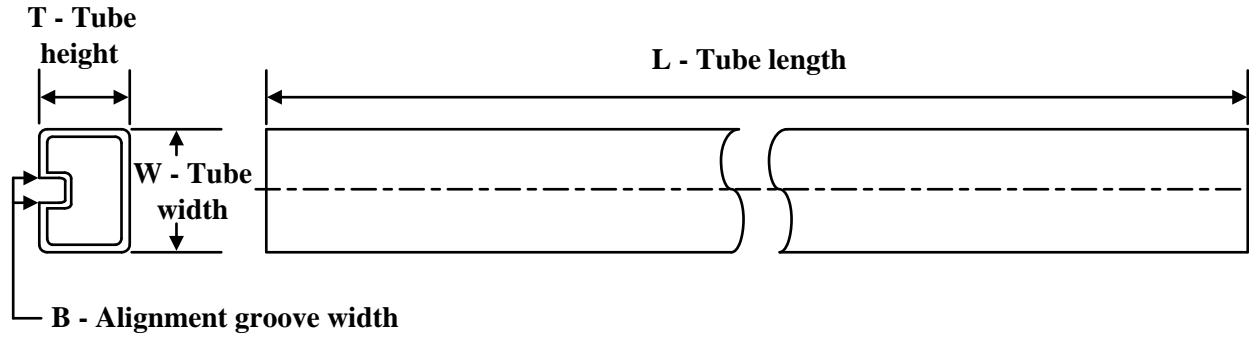
Device	Package Type	Package Drawing	Pins	SPQ	Length (mm)	Width (mm)	Height (mm)
AM26LS31CDBR	SSOP	DB	16	2000	356.0	356.0	35.0
AM26LS31CDR	SOIC	D	16	2500	356.0	356.0	35.0
AM26LS31CDR	SOIC	D	16	2500	340.5	336.1	32.0
AM26LS31CDRG4	SOIC	D	16	2500	340.5	336.1	32.0
AM26LS31CDRG4	SOIC	D	16	2500	356.0	356.0	35.0
AM26LS31CNSR	SO	NS	16	2000	367.0	367.0	38.0
AM26LS31INSR	SO	NS	16	2000	356.0	356.0	35.0

TUBE

*All dimensions are nominal

Device	Package Name	Package Type	Pins	SPQ	L (mm)	W (mm)	T (μm)	B (mm)
5962-7802301M2A	FK	LCCC	20	55	506.98	12.06	2030	NA
5962-7802301MFA	W	CFP	16	25	506.98	26.16	6220	NA
5962-7802301Q2A	FK	LCCC	20	55	506.98	12.06	2030	NA
AM26LS31CD	D	SOIC	16	40	506.6	8	3940	4.32
AM26LS31CD	D	SOIC	16	40	507	8	3940	4.32
AM26LS31CDE4	D	SOIC	16	40	507	8	3940	4.32
AM26LS31CDE4	D	SOIC	16	40	506.6	8	3940	4.32
AM26LS31CDG4	D	SOIC	16	40	506.6	8	3940	4.32
AM26LS31CDG4	D	SOIC	16	40	507	8	3940	4.32
AM26LS31CN	N	PDIP	16	25	506	13.97	11230	4.32
AM26LS31MFKB	FK	LCCC	20	55	506.98	12.06	2030	NA
AM26LS31MWB	W	CFP	16	25	506.98	26.16	6220	NA

W (R-GDFP-F16)

CERAMIC DUAL FLATPACK



- NOTES:
- A. All linear dimensions are in inches (millimeters).
 - B. This drawing is subject to change without notice.
 - C. This package can be hermetically sealed with a ceramic lid using glass frit.
 - D. Index point is provided on cap for terminal identification only.
 - E. Falls within MIL STD 1835 GDFP2-F16

GENERIC PACKAGE VIEW

FK 20

LCCC - 2.03 mm max height

8.89 x 8.89, 1.27 mm pitch

LEADLESS CERAMIC CHIP CARRIER

This image is a representation of the package family, actual package may vary.
Refer to the product data sheet for package details.



4229370VA\

J (R-GDIP-T**)

14 LEADS SHOWN

CERAMIC DUAL IN-LINE PACKAGE



DIM \ PINS **	14	16	18	20
A	0.300 (7,62) BSC	0.300 (7,62) BSC	0.300 (7,62) BSC	0.300 (7,62) BSC
B MAX	0.785 (19,94)	.840 (21,34)	0.960 (24,38)	1.060 (26,92)
B MIN	—	—	—	—
C MAX	0.300 (7,62)	0.300 (7,62)	0.310 (7,87)	0.300 (7,62)
C MIN	0.245 (6,22)	0.245 (6,22)	0.220 (5,59)	0.245 (6,22)



4040083/F 03/03

- NOTES:
- All linear dimensions are in inches (millimeters).
 - This drawing is subject to change without notice.
 - This package is hermetically sealed with a ceramic lid using glass frit.
 - Index point is provided on cap for terminal identification only on press ceramic glass frit seal only.
 - Falls within MIL STD 1835 GDIP1-T14, GDIP1-T16, GDIP1-T18 and GDIP1-T20.

N (R-PDIP-T**)

PLASTIC DUAL-IN-LINE PACKAGE

16 PINS SHOWN



4040049/E 12/2002

- NOTES:
- A. All linear dimensions are in inches (millimeters).
 - B. This drawing is subject to change without notice.
 - $\triangle C$ Falls within JEDEC MS-001, except 18 and 20 pin minimum body length (Dim A).
 - $\triangle D$ The 20 pin end lead shoulder width is a vendor option, either half or full width.



PACKAGE OUTLINE

NS0016A

SOP - 2.00 mm max height

SOP



NOTES:

1. All linear dimensions are in millimeters. Dimensions in parenthesis are for reference only. Dimensioning and tolerancing per ASME Y14.5M.
2. This drawing is subject to change without notice.
3. This dimension does not include mold flash, protrusions, or gate burrs. Mold flash, protrusions, or gate burrs shall not exceed 0.15 mm, per side.
4. This dimension does not include interlead flash. Interlead flash shall not exceed 0.25 mm, per side.

EXAMPLE BOARD LAYOUT

NS0016A

SOP - 2.00 mm max height

SOP



SOLDER MASK DETAILS

4220735/A 12/2021

NOTES: (continued)

5. Publication IPC-7351 may have alternate designs.

6. Solder mask tolerances between and around signal pads can vary based on board fabrication site.

EXAMPLE STENCIL DESIGN

NS0016A

SOP - 2.00 mm max height

SOP

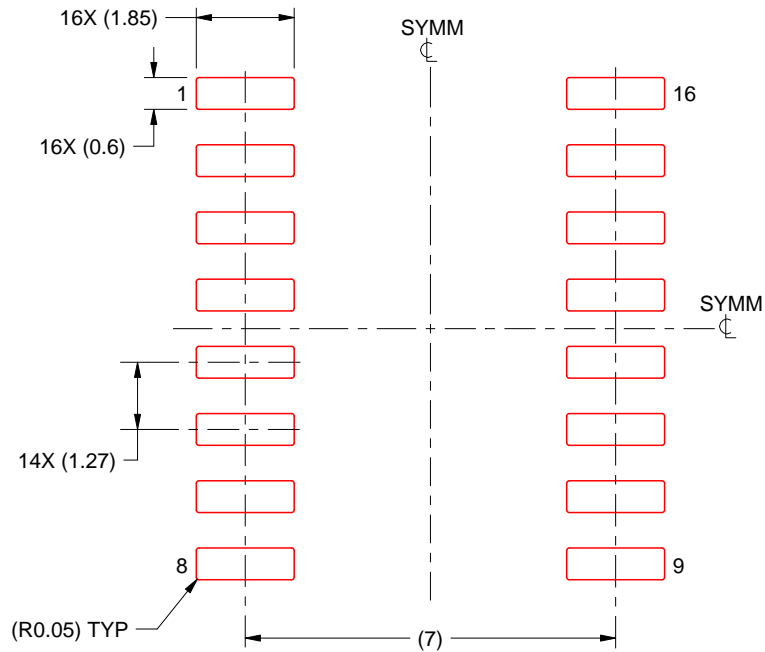

SOLDER PASTE EXAMPLE
BASED ON 0.125 mm THICK STENCIL
SCALE:7X

4220735/A 12/2021

NOTES: (continued)

7. Laser cutting apertures with trapezoidal walls and rounded corners may offer better paste release. IPC-7525 may have alternate design recommendations.
8. Board assembly site may have different recommendations for stencil design.

DB0016A



PACKAGE OUTLINE

SSOP - 2 mm max height

SMALL OUTLINE PACKAGE

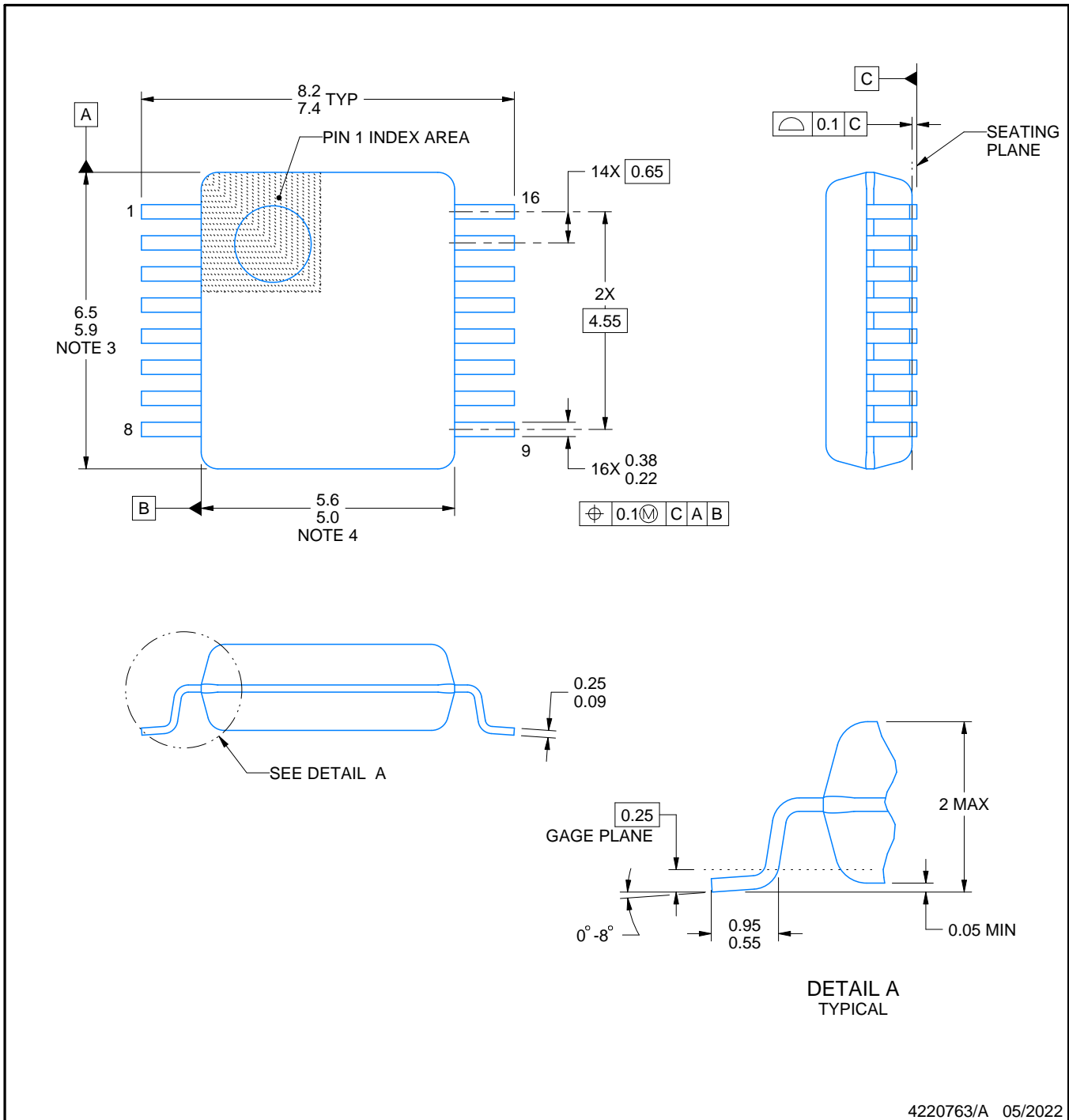

4220763/A 05/2022

NOTES:

1. All linear dimensions are in millimeters. Any dimensions in parenthesis are for reference only. Dimensioning and tolerancing per ASME Y14.5M.
2. This drawing is subject to change without notice.
3. This dimension does not include mold flash, protrusions, or gate burrs. Mold flash, protrusions, or gate burrs shall not exceed 0.15 mm per side.
4. Reference JEDEC registration MO-150.

EXAMPLE BOARD LAYOUT

DB0016A

SSOP - 2 mm max height

SMALL OUTLINE PACKAGE

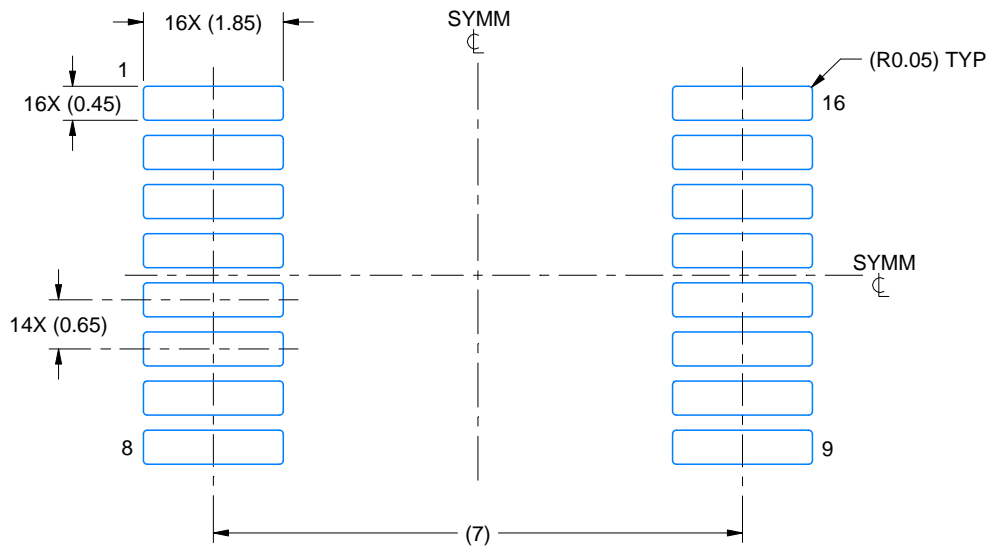

LAND PATTERN EXAMPLE
EXPOSED METAL SHOWN
SCALE: 10X

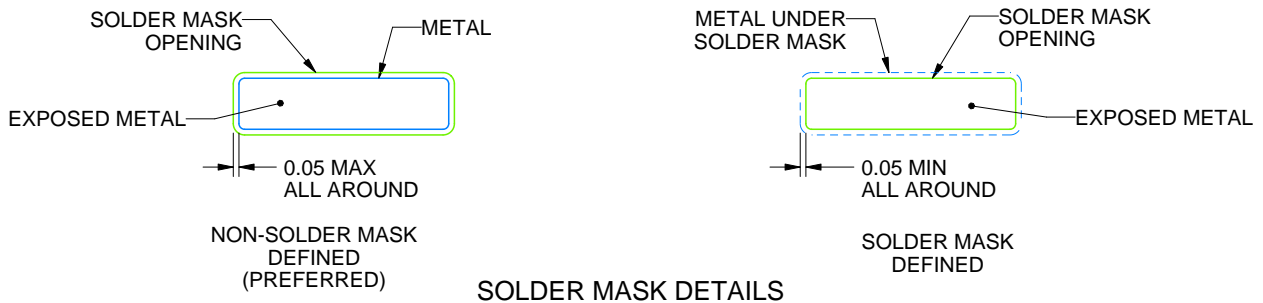

4220763/A 05/2022

NOTES: (continued)

- 5. Publication IPC-7351 may have alternate designs.
- 6. Solder mask tolerances between and around signal pads can vary based on board fabrication site.

EXAMPLE STENCIL DESIGN

DB0016A

SSOP - 2 mm max height

SMALL OUTLINE PACKAGE

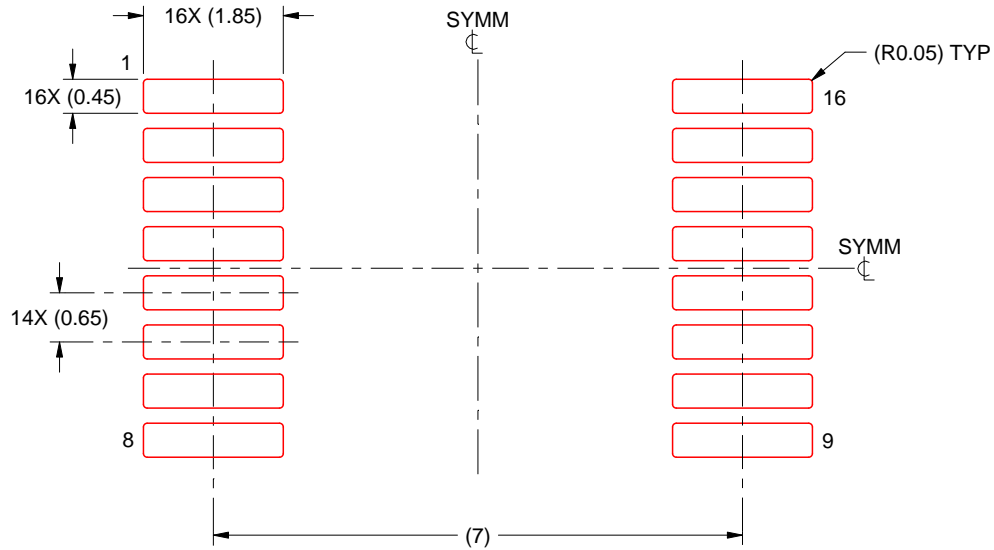

SOLDER PASTE EXAMPLE
BASED ON 0.125 mm THICK STENCIL
SCALE: 10X

4220763/A 05/2022

NOTES: (continued)

7. Laser cutting apertures with trapezoidal walls and rounded corners may offer better paste release. IPC-7525 may have alternate design recommendations.
8. Board assembly site may have different recommendations for stencil design.

MECHANICAL DATA

NS (R-PDSO-G**)

PLASTIC SMALL-OUTLINE PACKAGE

14-PINS SHOWN



- NOTES:
- A. All linear dimensions are in millimeters.
 - B. This drawing is subject to change without notice.
 - C. Body dimensions do not include mold flash or protrusion, not to exceed 0,15.

IMPORTANT NOTICE AND DISCLAIMER

TI PROVIDES TECHNICAL AND RELIABILITY DATA (INCLUDING DATA SHEETS), DESIGN RESOURCES (INCLUDING REFERENCE DESIGNS), APPLICATION OR OTHER DESIGN ADVICE, WEB TOOLS, SAFETY INFORMATION, AND OTHER RESOURCES "AS IS" AND WITH ALL FAULTS, AND DISCLAIMS ALL WARRANTIES, EXPRESS AND IMPLIED, INCLUDING WITHOUT LIMITATION ANY IMPLIED WARRANTIES OF MERCHANTABILITY, FITNESS FOR A PARTICULAR PURPOSE OR NON-INFRINGEMENT OF THIRD PARTY INTELLECTUAL PROPERTY RIGHTS.

These resources are intended for skilled developers designing with TI products. You are solely responsible for (1) selecting the appropriate TI products for your application, (2) designing, validating and testing your application, and (3) ensuring your application meets applicable standards, and any other safety, security, regulatory or other requirements.

These resources are subject to change without notice. TI grants you permission to use these resources only for development of an application that uses the TI products described in the resource. Other reproduction and display of these resources is prohibited. No license is granted to any other TI intellectual property right or to any third party intellectual property right. TI disclaims responsibility for, and you will fully indemnify TI and its representatives against, any claims, damages, costs, losses, and liabilities arising out of your use of these resources.

TI's products are provided subject to [TI's Terms of Sale](#) or other applicable terms available either on [ti.com](https://www.ti.com) or provided in conjunction with such TI products. TI's provision of these resources does not expand or otherwise alter TI's applicable warranties or warranty disclaimers for TI products.

TI objects to and rejects any additional or different terms you may have proposed.

Mailing Address: Texas Instruments, Post Office Box 655303, Dallas, Texas 75265
Copyright © 2024, Texas Instruments Incorporated

Looking for pricing, stock, or lifecycle information?

Click below to explore more details on WIN SOURCE:

 [View AM26LS31MJB](#) on WIN SOURCE

 [Texas Instruments](#) Information

Optimize Your Supply Chain with WIN SOURCE Solutions

-  Global Sourcing Solution
-  Obsolete Management
-  Cost Control Management
-  Shortage Management
-  Alternative Solution
-  Excess Inventory Management