



**THE DATASHEET OF  
TRSF3221EIPWR**



## FEATURES

- ESD Protection for RS-232 Pins
  - ±15-kV Human-Body Model (HBM)
  - ±8-kV IEC 61000-4-2 Contact Discharge
  - ±15-kV IEC 61000-4-2 Air-Gap Discharge
- Operates With 3-V to 5.5-V  $V_{CC}$  Supply
- Operates up to 1 Mbit/s
- Low Standby Current . . . 1  $\mu$ A Typ
- External Capacitors . . .  $4 \times 0.1 \mu$ F
- Accepts 5-V Logic Input With 3.3-V Supply
- RS-232 Bus-Pin ESD Protection Exceeds ±15 kV Using HBM
- Auto-Powerdown Feature Automatically Disables Drivers for Power Savings

## APPLICATIONS

- Battery-Powered, Hand-Held, and Portable Equipment
- PDAs and Palmtop PCs
- Notebooks, Sub-Notebooks, and Laptops
- Digital Cameras
- Mobile Phones and Wireless Devices

## DESCRIPTION/ORDERING INFORMATION

The TRSF3221E consists of one line driver, one line receiver, and a dual charge-pump circuit with ±15-kV IEC ESD protection pin to pin (serial-port connection pins, including GND). The TRSF3221E provides the electrical interface between an asynchronous communication controller and the serial-port connector. The charge pump and four small external capacitors allow operation from a single 3-V to 5.5-V supply. The TRSF3221E operates at data signaling rates up to 1 Mbit/s and a driver output slew rate of 24 V/ $\mu$ s to 150 V/ $\mu$ s.

Flexible control options for power management are available when the serial port is inactive. The auto-powerdown feature functions when FORCEON is low and FORCEOFF is high. During this mode of operation, if the TRSF3221E does not sense a valid RS-232 signal on the receiver input, the driver output is disabled. If FORCEOFF is set low and the enable ( $\overline{EN}$ ) input is high, both the driver and receiver are shut off, and the supply current is reduced to 1  $\mu$ A. Disconnecting the serial port or turning off the peripheral drivers causes the auto-powerdown condition to occur. Auto-powerdown can be disabled when FORCEON and FORCEOFF are high. With auto-powerdown enabled, the device is activated automatically when a valid signal is applied to the receiver input. The INVALID output notifies the user if an RS-232 signal is present at the receiver input. INVALID is high (valid data) if the receiver input voltage is greater than 2.7 V or less than –2.7 V, or has been between –0.3 V and 0.3 V for less than 30  $\mu$ s. INVALID is low (invalid data) if the receiver input voltage is between –0.3 V and 0.3 V for more than 30  $\mu$ s. See Figure 5 for receiver input levels.

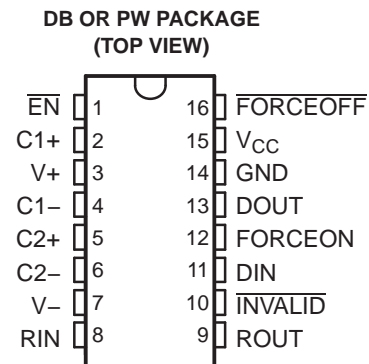

Please be aware that an important notice concerning availability, standard warranty, and use in critical applications of Texas Instruments semiconductor products and disclaimers thereto appears at the end of this data sheet.

**TRSF3221E**  
**3-V TO 5.5-V SINGLE-CHANNEL RS-232 1-Mbit/s LINE DRIVER/RECEIVER**  
**WITH ±15-kV IEC ESD PROTECTION**

SLLS822–JULY 2007

**ORDERING INFORMATION**

T <sub>A</sub>	PACKAGE <sup>(1)(2)</sup>		ORDERABLE PART NUMBER	TOP-SIDE MARKING
0°C to 70°C	SSOP – DB	Reel of 2000	TRSF3221ECDBR	RT21EC
	TSSOP – PW	Tube of 90	TRSF3221ECPW	RT21EC
		Reel of 2000	TRSF3221ECPWR	
–40°C to 85°C	SSOP – DB	Reel of 2000	TRSF3221EIDBR	RT21EI
	TSSOP – PW	Tube of 90	TRSF3221EIPW	RT21EI
		Reel of 2000	TRSF3221EIPWR	

- (1) Package drawings, standard packing quantities, thermal data, symbolization, and PCB design guidelines are available at [www.ti.com/sc/package](http://www.ti.com/sc/package).
- (2) For the most current package and ordering information, see the Package Option Addendum at the end of this document, or see the TI website at [www.ti.com](http://www.ti.com).

**FUNCTION TABLES**

**Each Driver<sup>(1)</sup>**

INPUTS				OUTPUT DOUT	DRIVER STATUS
DIN	FORCEON	FORCEOFF	VALID RIN RS-232 LEVEL		
X	X	L	X	Z	Powered off
L	H	H	X	H	Normal operation with auto-powerdown disabled
H	H	H	X	L	
L	L	H	Yes	H	Normal operation with auto-powerdown enabled
H	L	H	Yes	L	
L	L	H	No	Z	Powered off by auto-powerdown feature
H	L	H	No	Z	

- (1) H = high level, L = low level, X = irrelevant, Z = high impedance

**Each Receiver<sup>(1)</sup>**

INPUTS			OUTPUT ROUT
RIN	$\overline{\text{EN}}$	VALID RIN RS-232 LEVEL	
L	L	X	H
H	L	X	L
X	H	X	Z
Open	L	No	H

- (1) H = high level, L = low level, X = irrelevant, Z = high impedance (off), Open = disconnected input or connected driver off

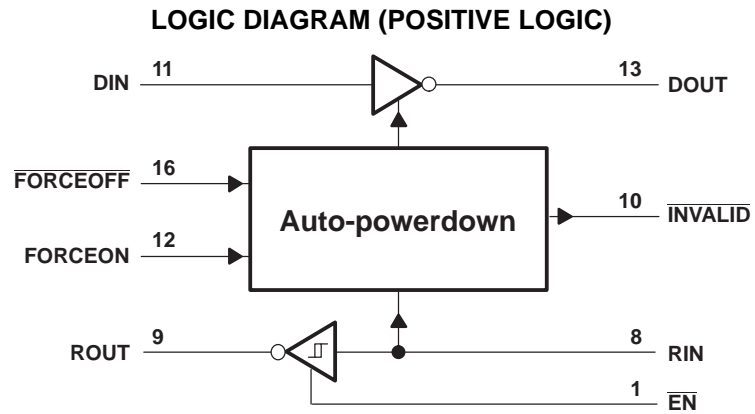

**TRSF3221E**  
**3-V TO 5.5-V SINGLE-CHANNEL RS-232 1-Mbit/s LINE DRIVER/RECEIVER**  
**WITH  $\pm 15$ -kV IEC ESD PROTECTION**

SLLS822–JULY 2007

**Table 1. 1-Mbit/s RS-232 Parts**

PART NO.	TEMPERATURE RANGE	DRIVER NO.	RECEIVER NO.	ESD	SUPPLY $V_{CC}$ (V)	FEATURE	PIN/PACKAGE
TRSF3221E	0°C to 70°C	1	1	$\pm 15$ -kV Air-Gap, $\pm 8$ -kV Contact, $\pm 15$ -kV HBM	3.3 or 5	Auto-powerdown	16-pin SOIC, SSOP, TSSOP
TRSF3232E		2	2	$\pm 15$ -kV Air-Gap, $\pm 8$ -kV Contact, $\pm 15$ -kV HBM	3.3 or 5	Low pin count	16-pin SOIC, SSOP, TSSOP
TRS3227		1	1	$\pm 8$ -kV Air-Gap, $\pm 8$ -kV Contact, $\pm 15$ -kV HBM	3.3 or 5	Auto-powerdown plus, ready signal	16-pin SSOP
TRSF3221		1	1	$\pm 15$ -kV HBM	3.3 or 5	Auto-powerdown	16-pin SOIC, SSOP, TSSOP
TRSF3223		2	2	$\pm 15$ -kV HBM	3.5 or 5	Auto-powerdown, enable signal	20-pin SOIC, SSOP, TSSOP
TRSF3222		2	2	$\pm 15$ -kV HBM	3.3 or 5	Enable, powerdown signal	20-pin SOIC, SSOP, TSSOP
TRSF3232		2	2	$\pm 15$ -kV HBM	3.3 or 5	Low pin count	16-pin SOIC, SSOP, TSSOP
TRSF3238		5	3	$\pm 15$ -kV HBM	3.3 or 5	Auto-powerdown plus	28-pin SOIC, SSOP, TSSOP
TRSF3243		3	5	$\pm 15$ -kV HBM	3.3 or 5	Auto-powerdown	28-pin SOIC, SSOP, TSSOP
TRSF3221E		–40°C to 85°C	1	1	$\pm 15$ -kV Air-Gap, $\pm 8$ -kV Contact, $\pm 15$ -kV HBM	3.3 or 5	Auto-powerdown
TRSF3232E	2		2	$\pm 15$ -kV Air-Gap, $\pm 8$ -kV Contact, $\pm 15$ -kV HBM	3.3 or 5	Low pin count	16-pin SOIC, SSOP, TSSOP
TRS3227	1		1	$\pm 8$ -kV Air-Gap, $\pm 8$ -k V Contact, $\pm 15$ -kV HBM	3.3 or 5	Auto-powerdown plus, ready signal	16-pin SSOP
TRSF3221	1		1	$\pm 15$ -kV HBM	3.3 or 5	Auto-powerdown	16-pin SOIC, SSOP, TSSOP
TRSF3223	2		2	$\pm 15$ -kV HBM	3.3 or 5	Auto-powerdown, enable signal	20-pin SOIC, SSOP, TSSOP
TRSF3222	2		2	$\pm 15$ -kV HBM	3.3 or 5	Enable, powerdown signal	20-pin SOIC, SSOP, TSSOP
TRSF3232	2		2	$\pm 15$ -kV HBM	3.3 or 5	Low pin count	16-pin SOIC, SSOP, TSSOP
TRSF3238	5		3	$\pm 15$ -kV HBM	3.3 or 5	Auto-powerdown plus	28-pin SOIC, SSOP, TSSOP
TRSF3243	3		5	$\pm 15$ -kV HBM	3.3 or 5	Auto-powerdown	28-pin SOIC, SSOP, TSSOP

## Absolute Maximum Ratings<sup>(1)</sup>

over operating free-air temperature range (unless otherwise noted)

		MIN	MAX	UNIT
V <sub>CC</sub>	Supply voltage range <sup>(2)</sup>	−0.3	6	V
V+	Positive output supply voltage range <sup>(2)</sup>	−0.3	7	V
V−	Negative output supply voltage range <sup>(2)</sup>	0.3	−7	V
V+ − V−	Supply voltage difference <sup>(2)</sup>		13	V
V <sub>I</sub>	Input voltage range	Driver (FORCEOFF, FORCEON, EN)		V
		Receiver		
V <sub>O</sub>	Output voltage range	Driver		V
		Receiver (INVALID)		
θ <sub>JA</sub>	Package thermal impedance <sup>(3)(4)</sup>	DB package		°C/W
		PW package		
T <sub>J</sub>	Operating virtual junction temperature		150	°C
T <sub>stg</sub>	Storage temperature range	−65	150	°C

- (1) Stresses beyond those listed under "absolute maximum ratings" may cause permanent damage to the device. These are stress ratings only, and functional operation of the device at these or any other conditions beyond those indicated under "recommended operating conditions" is not implied. Exposure to absolute-maximum-rated conditions for extended periods may affect device reliability.
- (2) All voltages are with respect to network GND.
- (3) Maximum power dissipation is a function of T<sub>J(max)</sub>, θ<sub>JA</sub>, and T<sub>A</sub>. The maximum allowable power dissipation at any allowable ambient temperature is P<sub>D</sub> = (T<sub>J(max)</sub> − T<sub>A</sub>)/θ<sub>JA</sub>. Operating at the absolute maximum T<sub>J</sub> of 150°C can affect reliability.
- (4) The package thermal impedance is calculated in accordance with JESD 51-7.

## Recommended Operating Conditions<sup>(1)</sup>

See [Figure 6](#)

		MIN	NOM	MAX	UNIT	
Supply voltage		V <sub>CC</sub> = 3.3 V	3	3.3	3.6	V
		V <sub>CC</sub> = 5 V	4.5	5	5.5	
V <sub>IH</sub>	Driver and control high-level input voltage	DIN, FORCEOFF, FORCEON, EN			V	
		V <sub>CC</sub> = 3.3 V	2			
		V <sub>CC</sub> = 5 V	2.4			
V <sub>IL</sub>	Driver and control low-level input voltage	DIN, FORCEOFF, FORCEON, EN		0.8	V	
V <sub>I</sub>	Driver and control input voltage	DIN, FORCEOFF, FORCEON		0	5.5	V
V <sub>I</sub>	Receiver input voltage			−25	25	V
T <sub>A</sub>	Operating free-air temperature	TRSF3221EI		−40	85	°C
		TRSF3221EC		0	70	

- (1) Test conditions are C1–C4 = 0.1 μF at V<sub>CC</sub> = 3.3 V ± 0.3 V; C1 = 0.047 μF, C2–C4 = 0.33 μF at V<sub>CC</sub> = 5 V ± 0.5 V.

## Electrical Characteristics<sup>(1)</sup>

over recommended ranges of supply voltage and operating free-air temperature (unless otherwise noted) (see [Figure 6](#))

PARAMETER		TEST CONDITIONS	MIN	TYP <sup>(2)</sup>	MAX	UNIT
I <sub>I</sub>	Input leakage current	FORCEOFF, FORCEON, EN		±0.01	±1	μA
I <sub>CC</sub>	Supply current (T <sub>A</sub> = 25°C)	Auto-powerdown disabled	No load, FORCEOFF and FORCEON at V <sub>CC</sub>	0.3	1	mA
		Powered off	No load, FORCEOFF at GND	1	10	
		Auto-powerdown enabled	No load, FORCEOFF at V <sub>CC</sub> , FORCEON at GND, All RIN are open or grounded	1	10	μA

- (1) Test conditions are C1–C4 = 0.1 μF at V<sub>CC</sub> = 3.3 V ± 0.3 V; C1 = 0.047 μF, C2–C4 = 0.33 μF at V<sub>CC</sub> = 5 V ± 0.5 V.
- (2) All typical values are at V<sub>CC</sub> = 3.3 V or V<sub>CC</sub> = 5 V, and T<sub>A</sub> = 25°C.

# TRSF3221E

## 3-V TO 5.5-V SINGLE-CHANNEL RS-232 1-Mbit/s LINE DRIVER/RECEIVER

### WITH $\pm 15$ -kV IEC ESD PROTECTION

SLLS822–JULY 2007

## DRIVER SECTION

### Electrical Characteristics<sup>(1)</sup>

over recommended ranges of supply voltage and operating free-air temperature (unless otherwise noted) (see [Figure 6](#))

PARAMETER	TEST CONDITIONS	MIN	TYP <sup>(2)</sup>	MAX	UNIT
V <sub>OH</sub>	High-level output voltage DOUT at R <sub>L</sub> = 3 k $\Omega$ to GND, DIN = GND	5	5.4		V
V <sub>OL</sub>	Low-level output voltage DOUT at R <sub>L</sub> = 3 k $\Omega$ to GND, DIN = V <sub>CC</sub>	–5	–5.4		V
I <sub>IH</sub>	High-level input current V <sub>I</sub> = V <sub>CC</sub>		$\pm 0.01$	$\pm 1$	$\mu$ A
I <sub>IL</sub>	Low-level input current V <sub>I</sub> at GND		$\pm 0.01$	$\pm 1$	$\mu$ A
I <sub>OS</sub>	Short-circuit output current <sup>(3)</sup> V <sub>CC</sub> = 3.6 V, V <sub>O</sub> = 0 V V <sub>CC</sub> = 5.5 V, V <sub>O</sub> = 0 V		$\pm 35$	$\pm 60$	mA
			$\pm 35$	$\pm 90$	
r <sub>o</sub>	Output resistance V <sub>CC</sub> , V+, and V– = 0 V, V <sub>O</sub> = $\pm 2$ V	300	10M		$\Omega$
I <sub>off</sub>	Output leakage current FORCEOFF = GND	V <sub>O</sub> = $\pm 12$ V, V <sub>CC</sub> = 3 V to 3.6 V		$\pm 25$	$\mu$ A
		V <sub>O</sub> = $\pm 10$ V, V <sub>CC</sub> = 4.5 V to 5.5 V		$\pm 25$	

(1) Test conditions are C1–C4 = 0.1  $\mu$ F at V<sub>CC</sub> = 3.3 V  $\pm$  0.3 V; C1 = 0.047  $\mu$ F, C2–C4 = 0.33  $\mu$ F at V<sub>CC</sub> = 5 V  $\pm$  0.5 V.

(2) All typical values are at V<sub>CC</sub> = 3.3 V or V<sub>CC</sub> = 5 V, and T<sub>A</sub> = 25°C.

(3) Short-circuit durations should be controlled to prevent exceeding the device absolute power dissipation ratings, and not more than one output should be shorted at a time.

### Switching Characteristics<sup>(1)</sup>

over recommended ranges of supply voltage and operating free-air temperature (unless otherwise noted) (see [Figure 6](#))

PARAMETER	TEST CONDITIONS	MIN	TYP <sup>(2)</sup>	MAX	UNIT
Maximum data rate (see <a href="#">Figure 1</a> )	R <sub>L</sub> = 3 k $\Omega$	C <sub>L</sub> = 1000 pF	250		kbit/s
		C <sub>L</sub> = 250 pF, V <sub>CC</sub> = 3 V to 4.5 V	1000		
		C <sub>L</sub> = 1000 pF, V <sub>CC</sub> = 4.5 V to 5.5 V	1000		
t <sub>sk(p)</sub>	Pulse skew <sup>(3)</sup> C <sub>L</sub> = 150 pF to 2500 pF, R <sub>L</sub> = 3 k $\Omega$ to 7 k $\Omega$ , See <a href="#">Figure 2</a>		100		ns
SR(tr)	Slew rate, transition region (see <a href="#">Figure 1</a> ) V <sub>CC</sub> = 3.3 V, R <sub>L</sub> = 3 k $\Omega$ to 7 k $\Omega$ , C <sub>L</sub> = 150 pF to 1000 pF	18		150	V/ $\mu$ s

(1) Test conditions are C1–C4 = 0.1  $\mu$ F at V<sub>CC</sub> = 3.3 V  $\pm$  0.3 V; C1 = 0.047  $\mu$ F, C2–C4 = 0.33  $\mu$ F at V<sub>CC</sub> = 5 V  $\pm$  0.5 V.

(2) All typical values are at V<sub>CC</sub> = 3.3 V or V<sub>CC</sub> = 5 V, and T<sub>A</sub> = 25°C.

(3) Pulse skew is defined as |t<sub>PLH</sub> – t<sub>PHL</sub>| of each channel of the same device.

## ESD Protection

TERMINAL		TEST CONDITIONS	TYP	UNIT
NAME	NO.			
DOUT	13	HBM	$\pm 15$	kV
		IEC 61000-4-2 Contact Discharge	$\pm 8$	
		IEC 61000-4-2 Air-Gap Discharge	$\pm 15$	

## RECEIVER SECTION

### Electrical Characteristics<sup>(1)</sup>

over recommended ranges of supply voltage and operating free-air temperature (unless otherwise noted) (see [Figure 6](#))

PARAMETER		TEST CONDITIONS	MIN	TYP <sup>(2)</sup>	MAX	UNIT
V <sub>OH</sub>	High-level output voltage	I <sub>OH</sub> = –1 mA	V <sub>CC</sub> – 0.6 V	V <sub>CC</sub> – 0.1 V		V
V <sub>OL</sub>	Low-level output voltage	I <sub>OL</sub> = 1.6 mA			0.4	V
V <sub>IT+</sub>	Positive-going input threshold voltage	V <sub>CC</sub> = 3.3 V		1.6	2.4	V
		V <sub>CC</sub> = 5 V		1.9	2.4	
V <sub>IT–</sub>	Negative-going input threshold voltage	V <sub>CC</sub> = 3.3 V	0.6	1.1		V
		V <sub>CC</sub> = 5 V	0.8	1.4		
V <sub>hys</sub>	Input hysteresis (V <sub>IT+</sub> – V <sub>IT–</sub> )			0.5		V
I <sub>off</sub>	Output leakage current	FORCEOFF = 0 V		±0.05	±10	µA
r <sub>i</sub>	Input resistance	V <sub>i</sub> = ±3 V to ±25 V	3	5	7	kΩ

(1) Test conditions are C1–C4 = 0.1 µF at V<sub>CC</sub> = 3.3 V ± 0.3 V; C1 = 0.047 µF, C2–C4 = 0.33 µF at V<sub>CC</sub> = 5 V ± 0.5 V.

(2) All typical values are at V<sub>CC</sub> = 3.3 V or V<sub>CC</sub> = 5 V, and T<sub>A</sub> = 25°C.

### Switching Characteristics<sup>(1)</sup>

over recommended ranges of supply voltage and operating free-air temperature (unless otherwise noted) (see [Figure 6](#))

PARAMETER		TEST CONDITIONS	TYP <sup>(2)</sup>	UNIT
t <sub>PLH</sub>	Propagation delay time, low- to high-level output	C <sub>L</sub> = 150 pF, See <a href="#">Figure 3</a>	150	ns
t <sub>PHL</sub>	Propagation delay time, high- to low-level output	C <sub>L</sub> = 150 pF, See <a href="#">Figure 3</a>	150	ns
t <sub>en</sub>	Output enable time	C <sub>L</sub> = 150 pF, R <sub>L</sub> = 3 kΩ, See <a href="#">Figure 4</a>	200	ns
t <sub>dis</sub>	Output disable time	C <sub>L</sub> = 150 pF, R <sub>L</sub> = 3 kΩ, See <a href="#">Figure 4</a>	200	ns
t <sub>sk(p)</sub>	Pulse skew <sup>(3)</sup>	See <a href="#">Figure 3</a>	50	ns

(1) Test conditions are C1–C4 = 0.1 µF at V<sub>CC</sub> = 3.3 V ± 0.3 V; C1 = 0.047 µF, C2–C4 = 0.33 µF at V<sub>CC</sub> = 5 V ± 0.5 V.

(2) All typical values are at V<sub>CC</sub> = 3.3 V or V<sub>CC</sub> = 5 V, and T<sub>A</sub> = 25°C.

(3) Pulse skew is defined as |t<sub>PLH</sub> – t<sub>PHL</sub>| of each channel of the same device.

## ESD Protection

TERMINAL		TEST CONDITIONS	TYP	UNIT
NAME	NO.			
RIN	8	HBM	±15	kV
		IEC 61000-4-2 Contact Discharge	±8	
		IEC 61000-4-2 Air-Gap Discharge	±15	

## AUTO-POWERDOWN SECTION

### Electrical Characteristics

over recommended ranges of supply voltage and operating free-air temperature (unless otherwise noted) (see [Figure 5](#))

PARAMETER		TEST CONDITIONS	MIN	MAX	UNIT
$V_{T+}$ (valid)	Receiver input threshold for $\overline{\text{INVALID}}$ high-level output voltage	FORCEON = GND, $\overline{\text{FORCEOFF}} = V_{CC}$		2.7	V
$V_{T-}$ (valid)	Receiver input threshold for $\overline{\text{INVALID}}$ high-level output voltage	FORCEON = GND, $\overline{\text{FORCEOFF}} = V_{CC}$	-2.7		V
$V_{T}$ (invalid)	Receiver input threshold for $\overline{\text{INVALID}}$ low-level output voltage	FORCEON = GND, $\overline{\text{FORCEOFF}} = V_{CC}$	-0.3	0.3	V
$V_{OH}$	$\overline{\text{INVALID}}$ high-level output voltage	$I_{OH} = -1$ mA, FORCEON = GND, $\overline{\text{FORCEOFF}} = V_{CC}$	$V_{CC} - 0.6$		V
$V_{OL}$	$\overline{\text{INVALID}}$ low-level output voltage	$I_{OL} = 1.6$ mA, FORCEON = GND, $\overline{\text{FORCEOFF}} = V_{CC}$		0.4	V

### Switching Characteristics

over recommended ranges of supply voltage and operating free-air temperature (unless otherwise noted) (see [Figure 5](#))

PARAMETER		TYP <sup>(1)</sup>	UNIT
$t_{\text{valid}}$	Propagation delay time, low- to high-level output	1	$\mu\text{s}$
$t_{\text{invalid}}$	Propagation delay time, high- to low-level output	30	$\mu\text{s}$
$t_{\text{en}}$	Supply enable time	100	$\mu\text{s}$

(1) All typical values are at  $V_{CC} = 3.3$  V or  $V_{CC} = 5$  V, and  $T_A = 25^\circ\text{C}$ .

PARAMETER MEASUREMENT INFORMATION

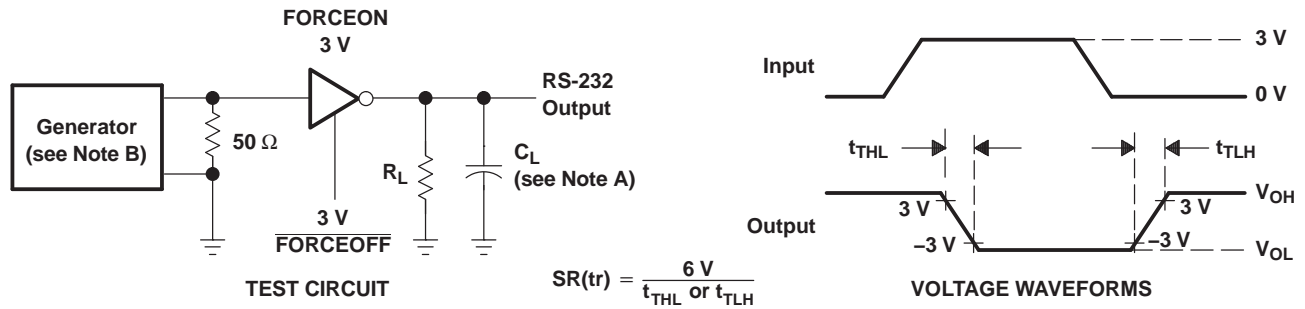

NOTES: A.  $C_L$  includes probe and jig capacitance.  
B. The pulse generator has the following characteristics: PRR = 250 kbit/s,  $Z_0 = 50 \Omega$ , 50% duty cycle,  $t_r \leq 10$  ns,  $t_f \leq 10$  ns.

Figure 1. Driver Slew Rate

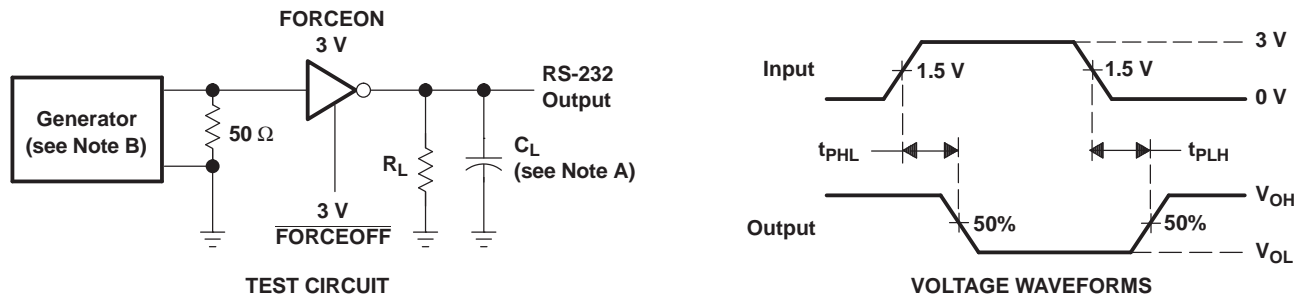

NOTES: A.  $C_L$  includes probe and jig capacitance.  
B. The pulse generator has the following characteristics: PRR = 250 kbit/s,  $Z_0 = 50 \Omega$ , 50% duty cycle,  $t_r \leq 10$  ns,  $t_f \leq 10$  ns.

Figure 2. Driver Pulse Skew

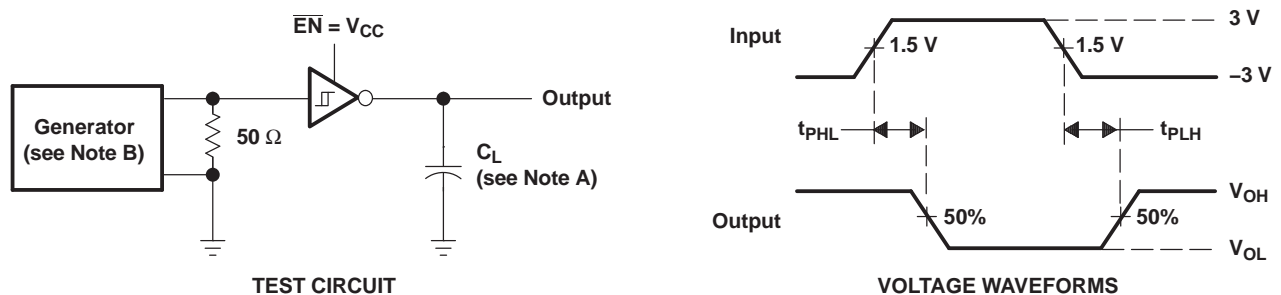

NOTES: A.  $C_L$  includes probe and jig capacitance.  
B. The pulse generator has the following characteristics:  $Z_0 = 50 \Omega$ , 50% duty cycle,  $t_r \leq 10$  ns,  $t_f \leq 10$  ns.

Figure 3. Receiver Propagation Delay Times

PARAMETER MEASUREMENT INFORMATION (continued)

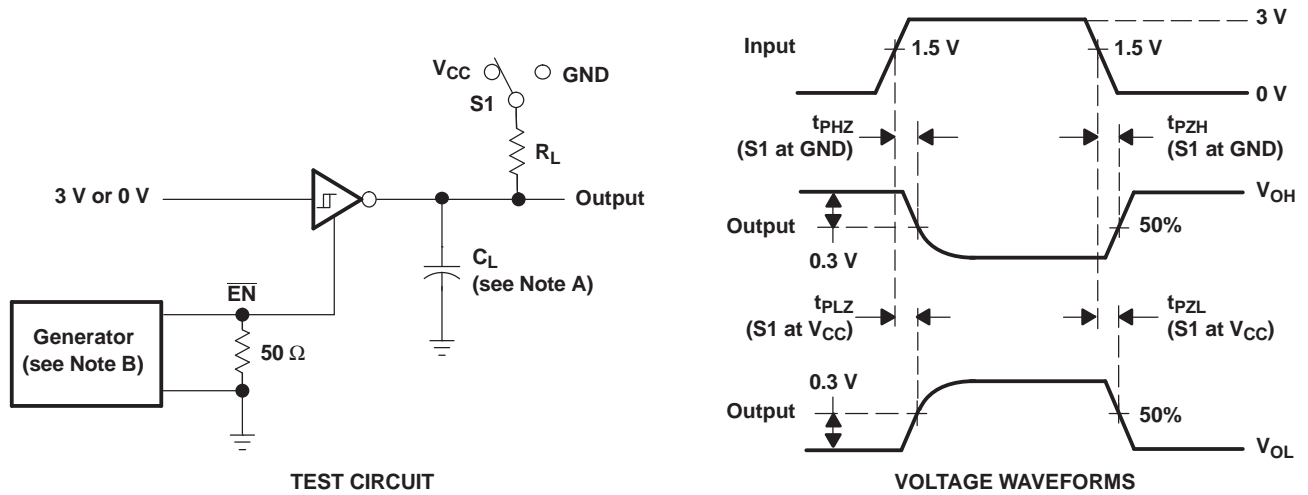

- NOTES: A.  $C_L$  includes probe and jig capacitance.  
 B. The pulse generator has the following characteristics:  $Z_O = 50 \Omega$ , 50% duty cycle,  $t_r \leq 10$  ns,  $t_f \leq 10$  ns.  
 C.  $t_{PLZ}$  and  $t_{PHZ}$  are the same as  $t_{dis}$ .  
 D.  $t_{PZL}$  and  $t_{PZH}$  are the same as  $t_{en}$ .

Figure 4. Receiver Enable and Disable Times

PARAMETER MEASUREMENT INFORMATION (continued)

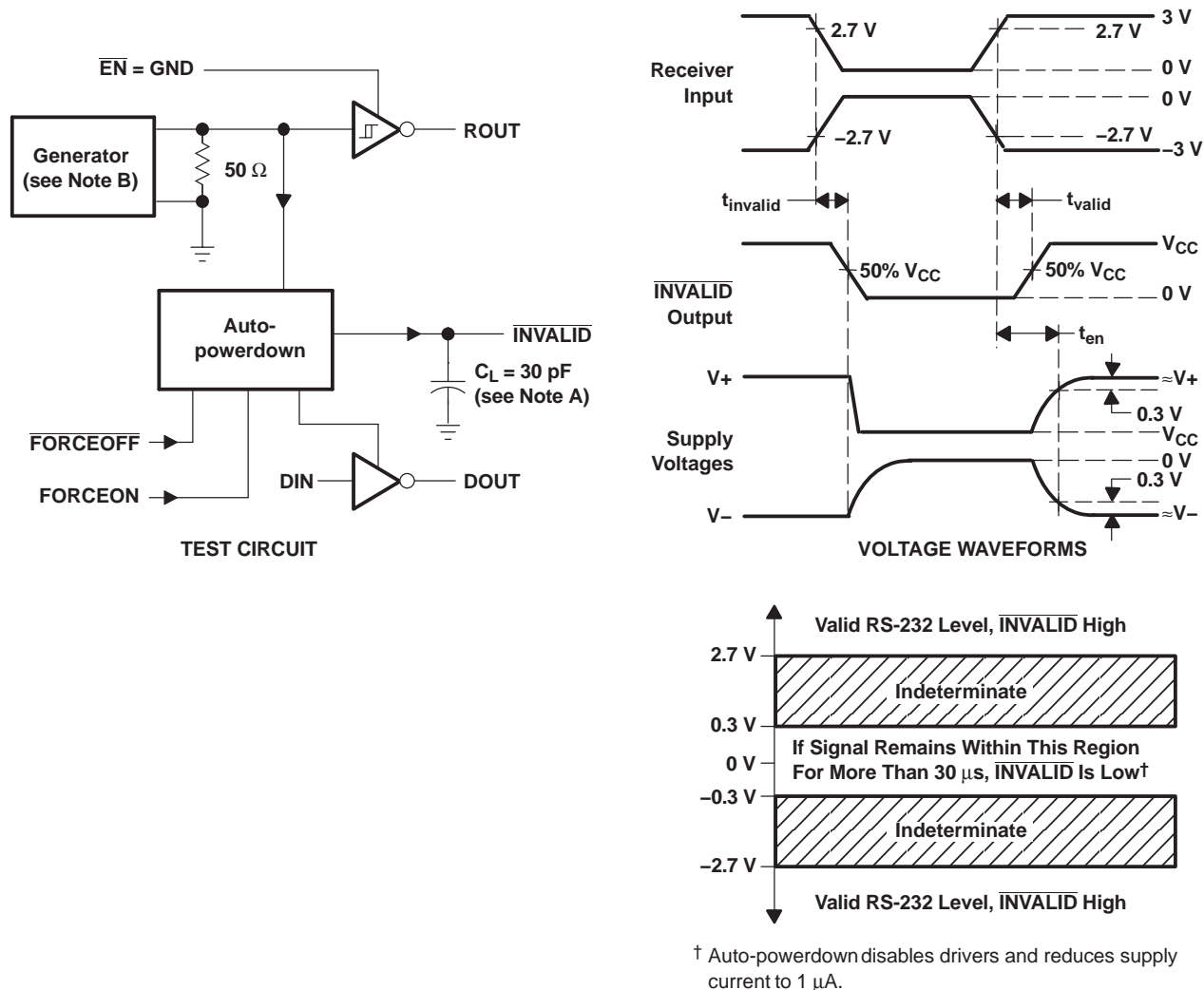

NOTES: A.  $C_L$  includes probe and jig capacitance.

B. The pulse generator has the following characteristics: PRR = 5 kbit/s,  $Z_O = 50$   $\Omega$ , 50% duty cycle,  $t_r \leq 10$  ns,  $t_f \leq 10$  ns.

Figure 5.  $\overline{INVALID}$  Propagation Delay Times and Driver Enabling Time

**APPLICATION INFORMATION**

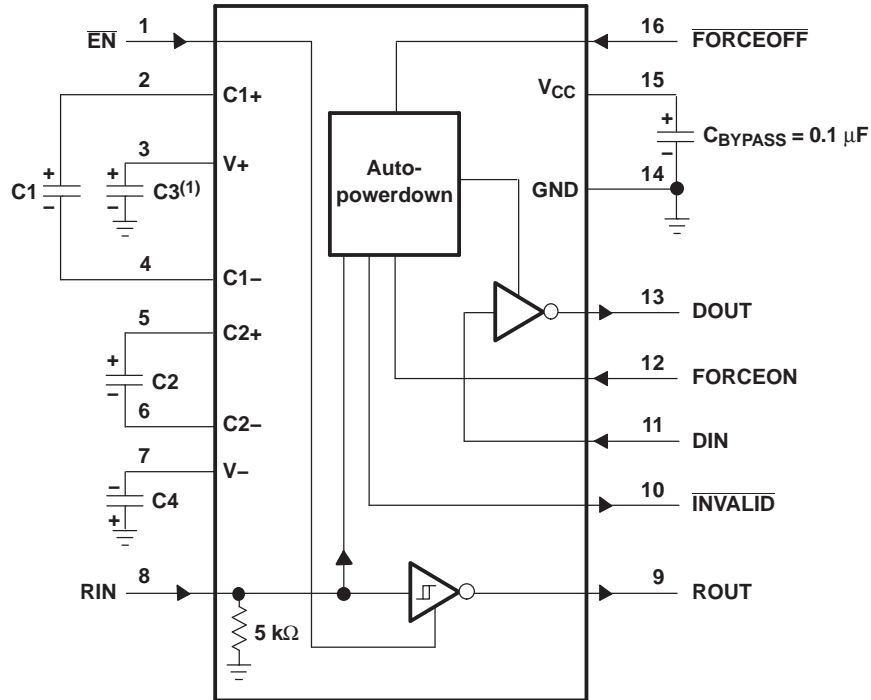

(1) C3 can be connected to  $V_{CC}$  or GND.

NOTES: A. Resistor values shown are nominal.

B. Nonpolarized ceramic capacitors are acceptable. If polarized tantalum or electrolytic capacitors are used, they should be connected as shown.

**$V_{CC}$  vs CAPACITOR VALUES**

$V_{CC}$	C1	C2, C3, and C4
3.3 V $\pm$ 0.3 V	0.1 $\mu$ F	0.1 $\mu$ F
5 V $\pm$ 0.5 V	0.047 $\mu$ F	0.33 $\mu$ F
3 V to 5.5 V	0.1 $\mu$ F	0.47 $\mu$ F

**Figure 6. Typical Operating Circuit and Capacitor Values**

**PACKAGING INFORMATION**

Orderable Device	Status (1)	Package Type	Package Drawing	Pins	Package Qty	Eco Plan (2)	Lead/Ball Finish (6)	MSL Peak Temp (3)	Op Temp (°C)	Device Marking (4/5)	Samples
TRSF3221ECDB	ACTIVE	SSOP	DB	16	80	Green (RoHS & no Sb/Br)	CU NIPDAU	Level-1-260C-UNLIM	0 to 70	RT21EC	<a href="#">Samples</a>
TRSF3221ECDBG4	ACTIVE	SSOP	DB	16	80	Green (RoHS & no Sb/Br)	CU NIPDAU	Level-1-260C-UNLIM	0 to 70	RT21EC	<a href="#">Samples</a>
TRSF3221ECDBR	ACTIVE	SSOP	DB	16	2000	Green (RoHS & no Sb/Br)	CU NIPDAU	Level-1-260C-UNLIM	0 to 70	RT21EC	<a href="#">Samples</a>
TRSF3221ECDBG4	ACTIVE	SSOP	DB	16	2000	Green (RoHS & no Sb/Br)	CU NIPDAU	Level-1-260C-UNLIM	0 to 70	RT21EC	<a href="#">Samples</a>
TRSF3221ECPW	ACTIVE	TSSOP	PW	16	90	Green (RoHS & no Sb/Br)	CU NIPDAU	Level-1-260C-UNLIM	0 to 70	RT21EC	<a href="#">Samples</a>
TRSF3221ECPWR	ACTIVE	TSSOP	PW	16	2000	Green (RoHS & no Sb/Br)	CU NIPDAU	Level-1-260C-UNLIM	0 to 70	RT21EC	<a href="#">Samples</a>
TRSF3221EIDBR	ACTIVE	SSOP	DB	16	2000	Green (RoHS & no Sb/Br)	CU NIPDAU	Level-1-260C-UNLIM	-40 to 85	RT21EI	<a href="#">Samples</a>
TRSF3221EIPW	ACTIVE	TSSOP	PW	16	90	Green (RoHS & no Sb/Br)	CU NIPDAU	Level-1-260C-UNLIM	-40 to 85	RT21EI	<a href="#">Samples</a>
TRSF3221EIPWR	ACTIVE	TSSOP	PW	16	2000	Green (RoHS & no Sb/Br)	CU NIPDAU	Level-1-260C-UNLIM	-40 to 85	RT21EI	<a href="#">Samples</a>
TRSF3221EIPWRG4	ACTIVE	TSSOP	PW	16	2000	Green (RoHS & no Sb/Br)	CU NIPDAU	Level-1-260C-UNLIM	-40 to 85	RT21EI	<a href="#">Samples</a>

(1) The marketing status values are defined as follows:

**ACTIVE:** Product device recommended for new designs.

**LIFEBUY:** TI has announced that the device will be discontinued, and a lifetime-buy period is in effect.

**NRND:** Not recommended for new designs. Device is in production to support existing customers, but TI does not recommend using this part in a new design.

**PREVIEW:** Device has been announced but is not in production. Samples may or may not be available.

**OBSOLETE:** TI has discontinued the production of the device.

(2) Eco Plan - The planned eco-friendly classification: Pb-Free (RoHS), Pb-Free (RoHS Exempt), or Green (RoHS & no Sb/Br) - please check <http://www.ti.com/productcontent> for the latest availability information and additional product content details.

**TBD:** The Pb-Free/Green conversion plan has not been defined.

**Pb-Free (RoHS):** TI's terms "Lead-Free" or "Pb-Free" mean semiconductor products that are compatible with the current RoHS requirements for all 6 substances, including the requirement that lead not exceed 0.1% by weight in homogeneous materials. Where designed to be soldered at high temperatures, TI Pb-Free products are suitable for use in specified lead-free processes.

**Pb-Free (RoHS Exempt):** This component has a RoHS exemption for either 1) lead-based flip-chip solder bumps used between the die and package, or 2) lead-based die adhesive used between the die and leadframe. The component is otherwise considered Pb-Free (RoHS compatible) as defined above.

**Green (RoHS & no Sb/Br):** TI defines "Green" to mean Pb-Free (RoHS compatible), and free of Bromine (Br) and Antimony (Sb) based flame retardants (Br or Sb do not exceed 0.1% by weight in homogeneous material)

- (3) MSL, Peak Temp. - The Moisture Sensitivity Level rating according to the JEDEC industry standard classifications, and peak solder temperature.
- (4) There may be additional marking, which relates to the logo, the lot trace code information, or the environmental category on the device.
- (5) Multiple Device Markings will be inside parentheses. Only one Device Marking contained in parentheses and separated by a "~" will appear on a device. If a line is indented then it is a continuation of the previous line and the two combined represent the entire Device Marking for that device.
- (6) Lead/Ball Finish - Orderable Devices may have multiple material finish options. Finish options are separated by a vertical ruled line. Lead/Ball Finish values may wrap to two lines if the finish value exceeds the maximum column width.

**Important Information and Disclaimer:**The information provided on this page represents TI's knowledge and belief as of the date that it is provided. TI bases its knowledge and belief on information provided by third parties, and makes no representation or warranty as to the accuracy of such information. Efforts are underway to better integrate information from third parties. TI has taken and continues to take reasonable steps to provide representative and accurate information but may not have conducted destructive testing or chemical analysis on incoming materials and chemicals. TI and TI suppliers consider certain information to be proprietary, and thus CAS numbers and other limited information may not be available for release.

In no event shall TI's liability arising out of such information exceed the total purchase price of the TI part(s) at issue in this document sold by TI to Customer on an annual basis.

**TAPE AND REEL INFORMATION**

**QUADRANT ASSIGNMENTS FOR PIN 1 ORIENTATION IN TAPE**

\*All dimensions are nominal

Device	Package Type	Package Drawing	Pins	SPQ	Reel Diameter (mm)	Reel Width W1 (mm)	A0 (mm)	B0 (mm)	K0 (mm)	P1 (mm)	W (mm)	Pin1 Quadrant
TRSF3221ECPWR	TSSOP	PW	16	2000	330.0	12.4	6.9	5.6	1.6	8.0	12.0	Q1
TRSF3221EIPWR	TSSOP	PW	16	2000	330.0	12.4	6.9	5.6	1.6	8.0	12.0	Q1

**TAPE AND REEL BOX DIMENSIONS**

\*All dimensions are nominal

Device	Package Type	Package Drawing	Pins	SPQ	Length (mm)	Width (mm)	Height (mm)
TRSF3221ECPWR	TSSOP	PW	16	2000	367.0	367.0	35.0
TRSF3221EIPWR	TSSOP	PW	16	2000	367.0	367.0	35.0



4220204/A 02/2017

NOTES:

1. All linear dimensions are in millimeters. Any dimensions in parenthesis are for reference only. Dimensioning and tolerancing per ASME Y14.5M.
2. This drawing is subject to change without notice.
3. This dimension does not include mold flash, protrusions, or gate burrs. Mold flash, protrusions, or gate burrs shall not exceed 0.15 mm per side.
4. This dimension does not include interlead flash. Interlead flash shall not exceed 0.25 mm per side.
5. Reference JEDEC registration MO-153.

# EXAMPLE BOARD LAYOUT

PW0016A

TSSOP - 1.2 mm max height

SMALL OUTLINE PACKAGE



LAND PATTERN EXAMPLE  
EXPOSED METAL SHOWN  
SCALE: 10X



4220204/A 02/2017

NOTES: (continued)

- 6. Publication IPC-7351 may have alternate designs.
- 7. Solder mask tolerances between and around signal pads can vary based on board fabrication site.

# EXAMPLE STENCIL DESIGN

PW0016A

TSSOP - 1.2 mm max height

SMALL OUTLINE PACKAGE



SOLDER PASTE EXAMPLE  
BASED ON 0.125 mm THICK STENCIL  
SCALE: 10X

4220204/A 02/2017

NOTES: (continued)

8. Laser cutting apertures with trapezoidal walls and rounded corners may offer better paste release. IPC-7525 may have alternate design recommendations.
9. Board assembly site may have different recommendations for stencil design.



## IMPORTANT NOTICE AND DISCLAIMER

TI PROVIDES TECHNICAL AND RELIABILITY DATA (INCLUDING DATASHEETS), DESIGN RESOURCES (INCLUDING REFERENCE DESIGNS), APPLICATION OR OTHER DESIGN ADVICE, WEB TOOLS, SAFETY INFORMATION, AND OTHER RESOURCES "AS IS" AND WITH ALL FAULTS, AND DISCLAIMS ALL WARRANTIES, EXPRESS AND IMPLIED, INCLUDING WITHOUT LIMITATION ANY IMPLIED WARRANTIES OF MERCHANTABILITY, FITNESS FOR A PARTICULAR PURPOSE OR NON-INFRINGEMENT OF THIRD PARTY INTELLECTUAL PROPERTY RIGHTS.

These resources are intended for skilled developers designing with TI products. You are solely responsible for (1) selecting the appropriate TI products for your application, (2) designing, validating and testing your application, and (3) ensuring your application meets applicable standards, and any other safety, security, or other requirements. These resources are subject to change without notice. TI grants you permission to use these resources only for development of an application that uses the TI products described in the resource. Other reproduction and display of these resources is prohibited. No license is granted to any other TI intellectual property right or to any third party intellectual property right. TI disclaims responsibility for, and you will fully indemnify TI and its representatives against, any claims, damages, costs, losses, and liabilities arising out of your use of these resources.

TI's products are provided subject to TI's Terms of Sale ([www.ti.com/legal/termsofsale.html](http://www.ti.com/legal/termsofsale.html)) or other applicable terms available either on [ti.com](http://ti.com) or provided in conjunction with such TI products. TI's provision of these resources does not expand or otherwise alter TI's applicable warranties or warranty disclaimers for TI products.

Mailing Address: Texas Instruments, Post Office Box 655303, Dallas, Texas 75265  
Copyright © 2018, Texas Instruments Incorporated

## Looking for pricing, stock, or lifecycle information?

Click below to explore more details on WIN SOURCE:

 [View TRSF3221EIPWR](#) on WIN SOURCE

 [Texas Instruments](#) Information

## Optimize Your Supply Chain with WIN SOURCE Solutions

-  Global Sourcing Solution
-  Obsolete Management
-  Cost Control Management
-  Shortage Management
-  Alternative Solution
-  Excess Inventory Management