



MICROCHIP

# MCP23008/MCP23S08

## 8-Bit I/O Expander with Serial Interface

### Features

- 8-Bit Remote Bidirectional I/O Port
  - I/O pins default to input
- High-Speed I<sup>2</sup>C Interface (**MCP23008**)
  - 100 kHz
  - 400 kHz
  - 1.7 MHz
- High-Speed SPI Interface (**MCP23S08**)
  - 10 MHz
- Hardware Address Pins
  - Three for the MCP23008 to allow up to eight devices on the bus
  - Two for the MCP23S08 to allow up to four devices using the same Chip Select
- Configurable Interrupt Output Pin
  - Configurable as active-high, active-low or open-drain
- Configurable Interrupt Source
  - Interrupt-on-change from configured defaults or pin change
- Polarity Inversion Register to Configure the Polarity of the Input Port Data
- External Reset Input
- Low Standby Current: 1  $\mu$ A (max.)
- Operating Voltage:
  - 1.8V to 5.5V at -40°C to +85°C I<sup>2</sup>C at 100 kHz  
SPI at 5 MHz
  - 2.7V to 5.5V at -40°C to +85°C I<sup>2</sup>C at 400 kHz  
SPI at 10 MHz
  - 4.5V to 5.5V at -40°C to +125°C I<sup>2</sup>C at 1.7 kHz  
SPI at 10 MHz

### Packages

- 18-pin PDIP (300 mil)
- 18-pin SOIC (300 mil)
- 20-pin SSOP
- 20-pin QFN

### Block Diagram

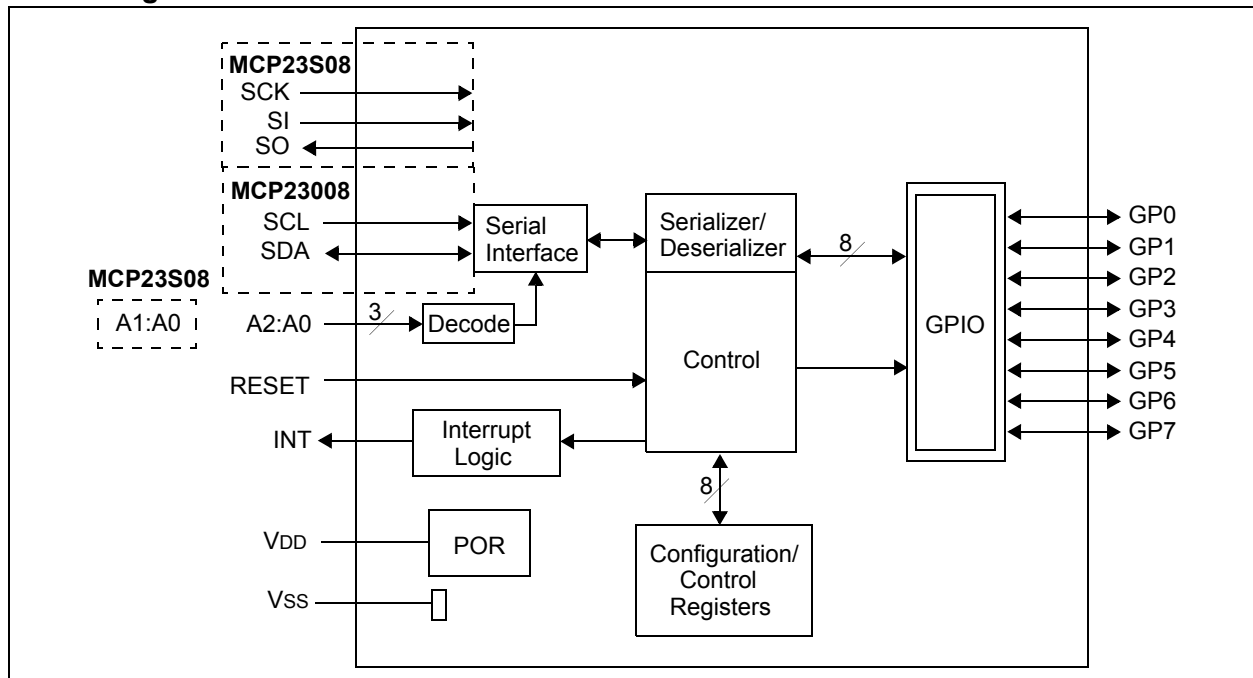

# MCP23008/MCP23S08

## Package Types

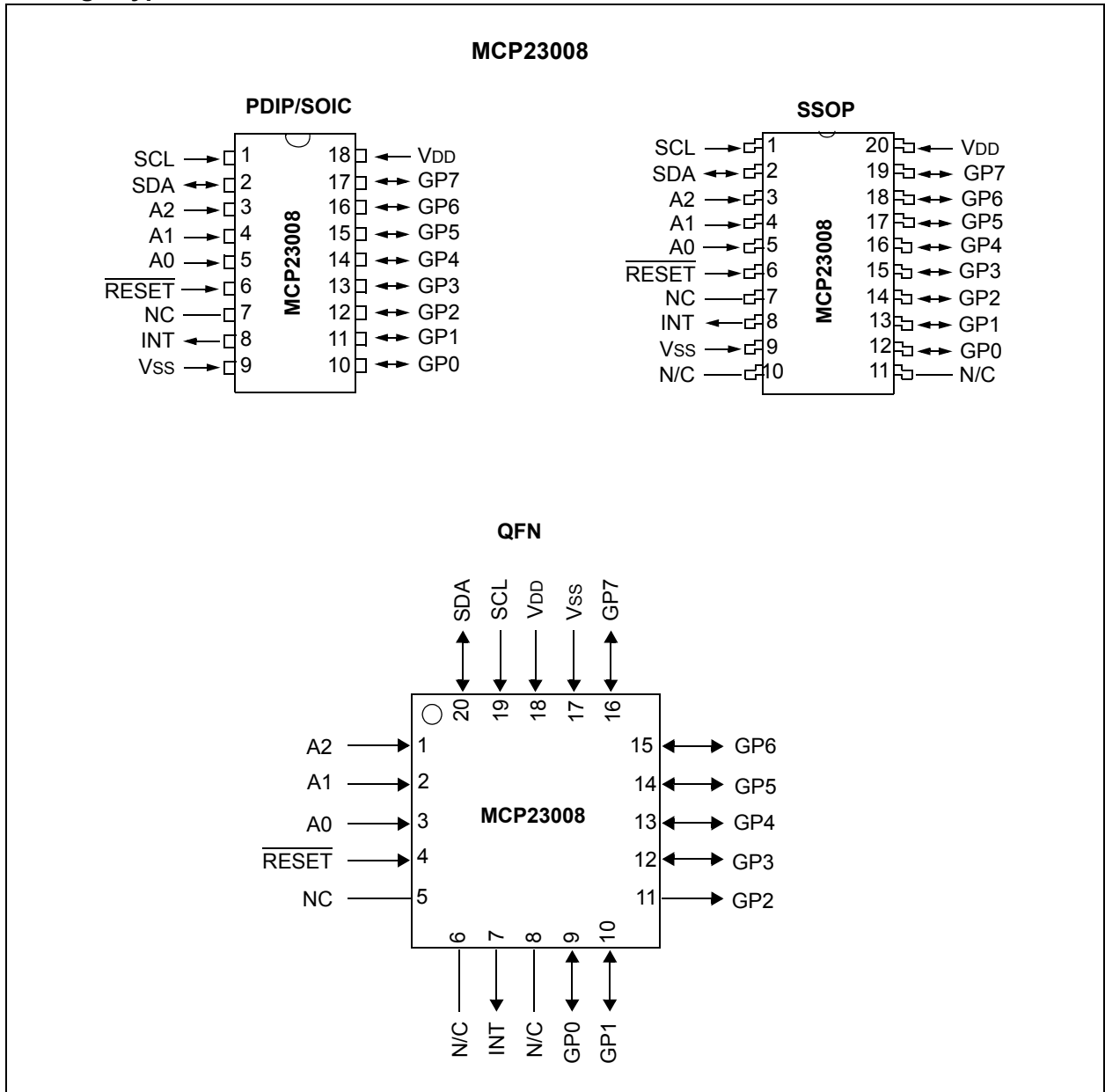

# MCP23008/MCP23S08

## Package Types: (Continued)

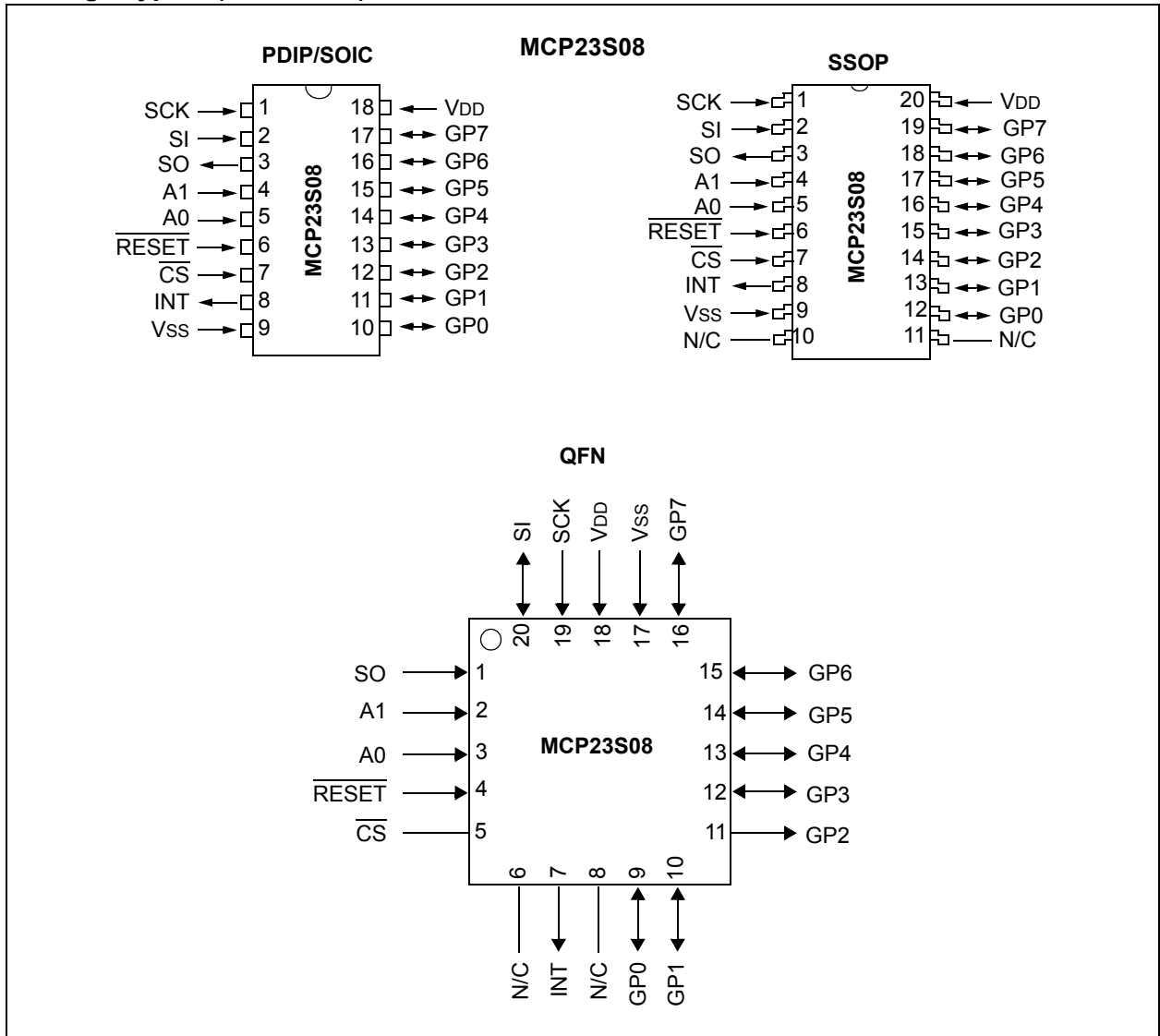

# MCP23008/MCP23S08

## 1.0 DEVICE OVERVIEW

The MCP23X08 device provides 8-bit, general purpose, parallel I/O expansion for I<sup>2</sup>C bus or SPI applications. The two devices differ in the number of hardware address pins and the serial interface:

- MCP23008 – I<sup>2</sup>C interface; three address pins
- MCP23S08 – SPI interface; two address pins

The MCP23X08 consists of multiple 8-bit Configuration registers for input, output and polarity selection. The system master can enable the I/Os as either inputs or outputs by writing the I/O Configuration bits. The data for each input or output is kept in the corresponding Input or Output register. The polarity of the Input Port register can be inverted with the Polarity Inversion register. All registers can be read by the system master.

The interrupt output can be configured to activate under two conditions (mutually exclusive):

1. When any input state differs from its corresponding Input Port register state, this is used to indicate to the system master that an input state has changed.
2. When an input state differs from a preconfigured register value (DEFVAL register).

The Interrupt Capture register captures port values at the time of the interrupt, thereby saving the condition that caused the interrupt.

The Power-on Reset (POR) sets the registers to their default values and initializes the device state machine.

The hardware address pins are used to determine the device address.

## 1.1 Pin Descriptions

TABLE 1-1: PINOUT DESCRIPTION

Pin Name	PDIP/ SOIC	QFN	SSOP	Pin Type	Function
SCL/SCK	1	19	1	I	Serial clock input.
SDA/SI	2	20	2	I/O	Serial data I/O ( <b>MCP23008</b> )/Serial data input ( <b>MCP23S08</b> ).
A2/SO	3	1	3	I/O	Hardware address input ( <b>MCP23008</b> )/ Serial data output ( <b>MCP23S08</b> ). A2 must be biased externally.
A1	4	2	4	I	Hardware address input. Must be biased externally.
A0	5	3	5	I	Hardware address input. Must be biased externally.
RESET	6	4	6	I	External Reset input. Must be biased externally.
NC/ $\overline{CS}$	7	5	7	I	No connect ( <b>MCP23008</b> )/External Chip Select input ( <b>MCP23S08</b> ).
INT	8	7	8	O	Interrupt output. Can be configured for active-high, active-low or open-drain.
Vss	9	17	9	P	Ground.
GP0	10	9	12	I/O	Bidirectional I/O pin. Can be enabled for interrupt-on-change and/or internal weak pull-up resistor.
GP1	11	10	13	I/O	Bidirectional I/O pin. Can be enabled for interrupt-on-change and/or internal weak pull-up resistor.
GP2	12	11	14	I/O	Bidirectional I/O pin. Can be enabled for interrupt-on-change and/or internal weak pull-up resistor.
GP3	13	12	15	I/O	Bidirectional I/O pin. Can be enabled for interrupt-on-change and/or internal weak pull-up resistor.
GP4	14	13	16	I/O	Bidirectional I/O pin. Can be enabled for interrupt-on-change and/or internal weak pull-up resistor.
GP5	15	14	17	I/O	Bidirectional I/O pin. Can be enabled for interrupt-on-change and/or internal weak pull-up resistor.
GP6	16	15	18	I/O	Bidirectional I/O pin. Can be enabled for interrupt-on-change and/or internal weak pull-up resistor.
GP7	17	16	19	I/O	Bidirectional I/O pin. Can be enabled for interrupt-on-change and/or internal weak pull-up resistor.
VDD	18	18	20	P	Power.
N/C	—	6, 8	10, 11	—	—

## 1.2 Power-on Reset (POR)

The on-chip POR circuit holds the device in Reset until VDD has reached a high enough voltage to deactivate the POR circuit (i.e., release the device from Reset). The maximum VDD rise time is specified in [Section 2.0, Electrical Characteristics](#).

When the device exits the POR condition (releases Reset), device operating parameters (i.e., voltage, temperature, serial bus frequency, etc.) must be met to ensure proper operation.

## 1.3 Serial Interface

This block handles the functionality of the I<sup>2</sup>C (MCP23008) or SPI (MCP23S08) interface protocol. The MCP23X08 contains eleven registers that can be addressed through the serial interface block ([Table 1-2](#)):

**TABLE 1-2: REGISTER ADDRESSES**

Address	Access to:
00h	IODIR
01h	IPOL
02h	GPINTEN
03h	DEFVAL
04h	INTCON
05h	IOCON
06h	GPPU
07h	INTF
08h	INTCAP (Read-only)
09h	GPIO
0Ah	OLAT

### 1.3.1 SEQUENTIAL OPERATION BIT

The Sequential Operation (SEQOP) bit (IOCON register) controls the operation of the Address Pointer. The Address Pointer can either be enabled (default) to allow the Address Pointer to increment automatically after each data transfer, or it can be disabled.

When operating in **Sequential mode** (IOCON.SEQOP = 0), the Address Pointer automatically increments to the next address after each byte is clocked.

When operating in **Byte mode** (IOCON.SEQOP = 1), the MCP23X08 does not increment its address counter after each byte during the data transfer. This gives the ability to continually read the same address by providing extra clocks (without additional control bytes). This is useful for polling the GPIO register for data changes.

### 1.3.2 I<sup>2</sup>C INTERFACE

#### 1.3.2.1 I<sup>2</sup>C Write Operation

The I<sup>2</sup>C Write operation includes the control byte and register address sequence, as shown in the bottom of [Figure 1-1](#). This sequence is followed by eight bits of data from the master and an Acknowledge (ACK) from the MCP23008. The operation is ended with a STOP or RESTART condition being generated by the master.

Data is written to the MCP23008 after every byte transfer. If a STOP or RESTART condition is generated during a data transfer, the data will not be written to the MCP23008.

Byte writes and sequential writes are both supported by the MCP23008. The MCP23008 increments its address counter after each ACK during the data transfer.

#### 1.3.2.2 I<sup>2</sup>C Read Operation

The I<sup>2</sup>C Read operation includes the control byte sequence, as shown in the bottom of [Figure 1-1](#). This sequence is followed by another control byte (including the START condition and ACK) with the R/W bit equal to a logic '1' (R/W = 1). The MCP23008 then transmits the data contained in the addressed register. The sequence is ended with the master generating a STOP or RESTART condition.

#### 1.3.2.3 I<sup>2</sup>C Sequential Write/Read

For sequential operations (Write or Read), instead of transmitting a STOP or RESTART condition after the data transfer, the master clocks the next byte pointed to by the Address Pointer (see [Section 1.3.1 "Sequential Operation Bit"](#) for details regarding sequential operation control).

The sequence ends with the master sending a STOP or RESTART condition.

The MCP23008 Address Pointer will roll over to address zero after reaching the last register address.

Refer to [Figure 1-1](#).

### 1.3.3 SPI INTERFACE

#### 1.3.3.1 SPI Write Operation

The SPI Write operation is started by lowering  $\overline{CS}$ . The Write command (slave address with R/W bit cleared) is then clocked into the device. The opcode is followed by an address and at least one data byte.

#### 1.3.3.2 SPI Read Operation

The SPI Read operation is started by lowering  $\overline{CS}$ . The SPI Read command (slave address with R/W bit set) is then clocked into the device. The opcode is followed by an address, with at least one data byte being clocked out of the device.

# MCP23008/MCP23S08

FIGURE 1-1: MCP23008 I<sup>2</sup>C DEVICE PROTOCOL

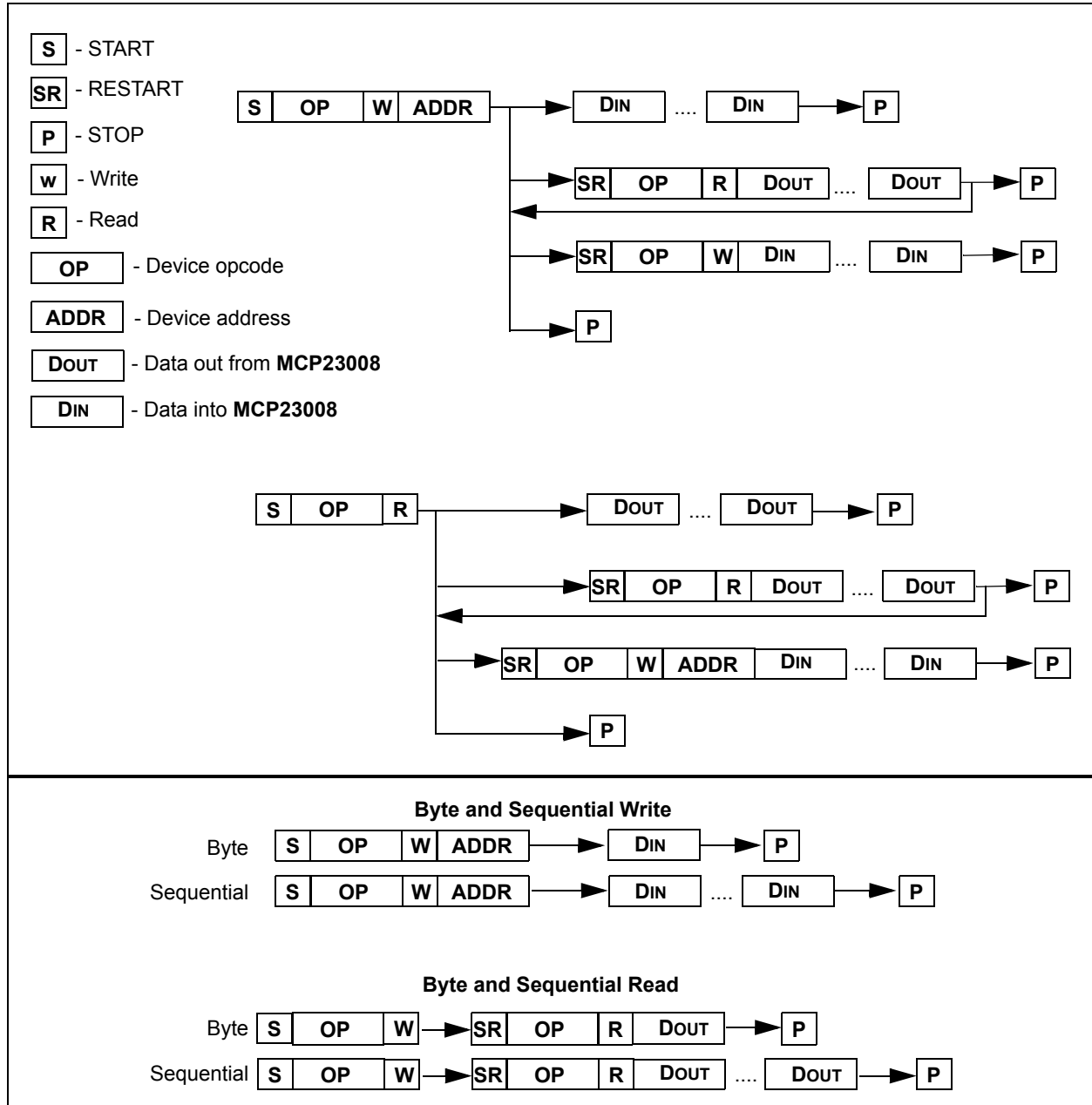

### 1.3.3.3 SPI Sequential Write/Read

For sequential operations, instead of deselecting the device by raising  $\overline{CS}$ , the master clocks the next byte pointed to by the Address Pointer.

The sequence ends by the raising of  $\overline{CS}$ .

The MCP23S08 Address Pointer will roll over to address zero after reaching the last register address.

### 1.4 Hardware Address Decoder

The hardware address pins are used to determine the device address. To address a device, the corresponding address bits in the control byte must match the pin state.

- MCP23008 has address pins A2, A1 and A0.
- MCP23S08 has address pins A1 and A0.

The pins must be biased externally.

# MCP23008/MCP23S08

## 1.4.1 ADDRESSING I<sup>2</sup>C DEVICES (MCP23008)

The MCP23008 is a slave I<sup>2</sup>C device that supports 7-bit slave addressing, with the read/write bit filling out the control byte. The slave address contains four fixed bits and three user-defined hardware address bits (pins A2, A1 and A0). [Figure 1-2](#) shows the control byte format.

## 1.4.2 ADDRESSING SPI DEVICES (MCP23S08)

The MCP23S08 is a slave SPI device. The slave address contains five fixed bits and two user-defined hardware address bits (pins A1 and A0), with the read/write bit filling out the control byte. [Figure 1-3](#) shows the control byte format.

**FIGURE 1-2: I<sup>2</sup>C CONTROL BYTE FORMAT**

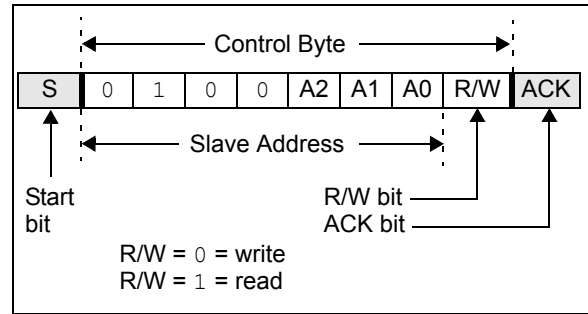

**FIGURE 1-3: SPI CONTROL BYTE FORMAT**

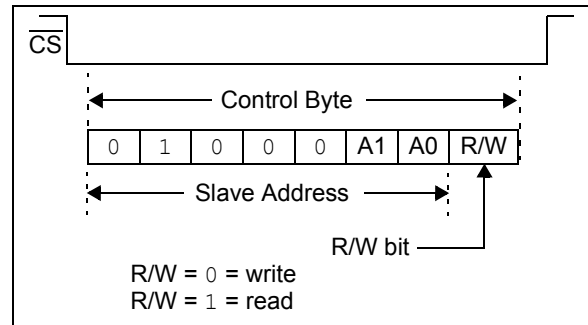

**FIGURE 1-4: I<sup>2</sup>C ADDRESSING REGISTERS**

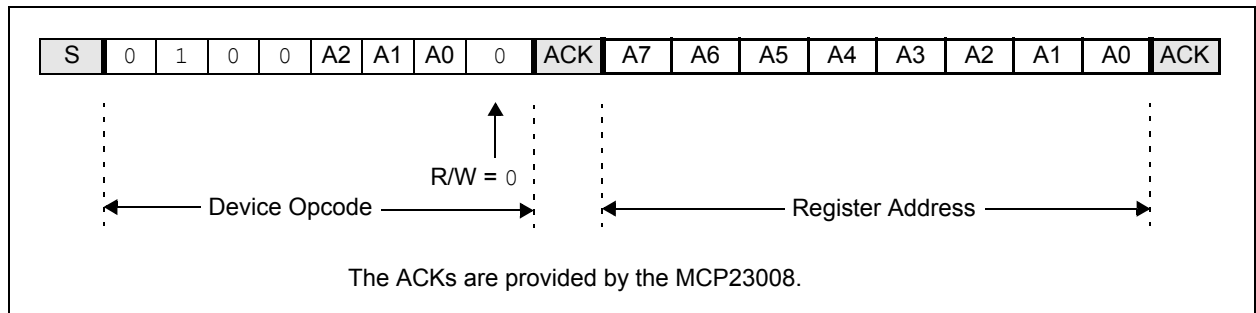

**FIGURE 1-5: SPI ADDRESSING REGISTERS**

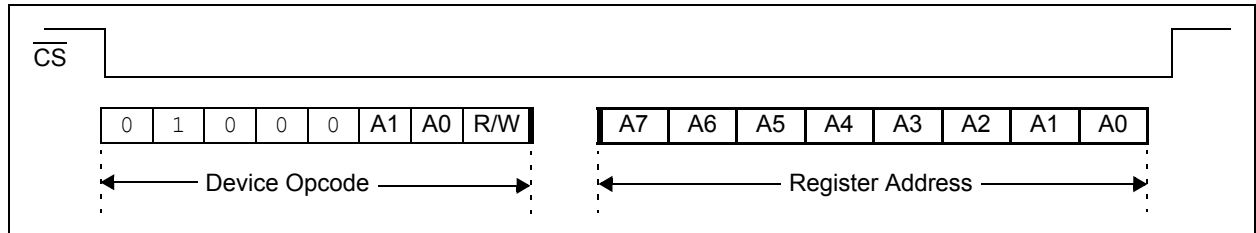

# MCP23008/MCP23S08

## 1.5 GPIO Port

The GPIO module contains the data port (GPIO), internal pull-up resistors and the Output Latches (OLAT).

Reading the GPIO register reads the value on the port. Reading the OLAT register only reads the OLAT, not the actual value on the port.

Writing to the GPIO register actually causes a write to the OLAT. Writing to the OLAT register forces the associated output drivers to drive to the level in OLAT. Pins configured as inputs turn off the associated output driver and put it in high-impedance.

## 1.6 Configuration and Control Registers

The Configuration and Control blocks contain the registers as shown in [Table 1-3](#).

**TABLE 1-3: CONFIGURATION AND CONTROL REGISTERS**

Register Name	Address (hex)	bit 7	bit 6	bit 5	bit 4	bit 3	bit 2	bit 1	bit 0	POR/RST value
IODIR	00	IO7	IO6	IO5	IO4	IO3	IO2	IO1	IO0	1111 1111
IPOL	01	IP7	IP6	IP5	IP4	IP3	IP2	IP1	IP0	0000 0000
GPINTEN	02	GPINT7	GPINT6	GPINT5	GPINT4	GPINT3	GPINT2	GPINT1	GPINT0	0000 0000
DEFVAL	03	DEF7	DEF6	DEF5	DEF4	DEF3	DEF2	DEF1	DEF0	0000 0000
INTCON	04	IOC7	IOC6	IOC5	IOC4	IOC3	IOC2	IOC1	IOC0	0000 0000
IOCON	05	—	—	SREAD	DISSLW	HAEN*	ODR	INTPOL	—	--00 000-
GPPU	06	PU7	PU6	PU5	PU4	PU3	PU2	PU1	PU0	0000 0000
INTF	07	INT7	INT6	INT5	INT4	INT3	INT2	INT1	INT0	0000 0000
INTCAP	08	ICP7	ICP6	ICP5	ICP4	ICP3	ICP2	ICP1	ICP0	0000 0000
GPIO	09	GP7	GP6	GP5	GP4	GP3	GP2	GP1	GP0	0000 0000
OLAT	0A	OL7	OL6	OL5	OL4	OL3	OL2	OL1	OL0	0000 0000

\* Not used on the MCP23008.

## 1.6.1 I/O DIRECTION (IODIR) REGISTER

Controls the direction of the data I/O.

When a bit is set, the corresponding pin becomes an input. When a bit is clear, the corresponding pin becomes an output.

### REGISTER 1-1: IODIR – I/O DIRECTION REGISTER (ADDR 0x00)

R/W-1	R/W-1	R/W-1	R/W-1	R/W-1	R/W-1	R/W-1	R/W-1
IO7	IO6	IO5	IO4	IO3	IO2	IO1	IO0
bit 7							bit 0

#### Legend:

R = Readable bit

W = Writable bit

U = Unimplemented bit, read as '0'

-n = Value at POR

'1' = Bit is set

'0' = Bit is cleared

x = Bit is unknown

bit 7-0

**IO7:IO0:** These bits control the direction of data I/O [7:0]

1 = Pin is configured as an input

0 = Pin is configured as an output

## 1.6.2 INPUT POLARITY (IPOL) REGISTER

The IPOL register allows the user to configure the polarity on the corresponding GPIO port bits.

If a bit is set, the corresponding GPIO register bit will reflect the inverted value on the pin.

### REGISTER 1-2: IPOL – INPUT POLARITY PORT REGISTER (ADDR 0x01)

R/W-0	R/W-0	R/W-0	R/W-0	R/W-0	R/W-0	R/W-0	R/W-0
IP7	IP6	IP5	IP4	IP3	IP2	IP1	IP0
bit 7							bit 0

#### Legend:

R = Readable bit

W = Writable bit

U = Unimplemented bit, read as '0'

-n = Value at POR

'1' = Bit is set

'0' = Bit is cleared

x = Bit is unknown

bit 7-0

**IP7:IP0:** These bits control the polarity inversion of the input pins [7:0]

1 = GPIO register bit will reflect the opposite logic state of the input pin

0 = GPIO register bit will reflect the same logic state of the input pin

## 1.6.3 INTERRUPT-ON-CHANGE CONTROL (GPINTEN) REGISTER

The GPINTEN register controls the interrupt-on-change feature for each pin.

If a bit is set, the corresponding pin is enabled for interrupt-on-change. The DEFVAL and INTCON registers must also be configured if any pins are enabled for interrupt-on-change.

### REGISTER 1-3: GPINTEN – INTERRUPT-ON-CHANGE PINS (ADDR 0x02)

R/W-0	R/W-0	R/W-0	R/W-0	R/W-0	R/W-0	R/W-0	R/W-0
GPINT7	GPINT6	GPINT5	GPINT4	GPINT3	GPINT2	GPINT1	GPINT0
bit 7							bit 0

#### Legend:

R = Readable bit

W = Writable bit

U = Unimplemented bit, read as '0'

-n = Value at POR

'1' = Bit is set

'0' = Bit is cleared

x = Bit is unknown

bit 7-0

**GPINT7:GPINT0:** General Purpose I/O Interrupt-on-Change [7:0]

1 = Enable GPIO input pin for interrupt-on-change event

0 = Disable GPIO input pin for interrupt-on-change event

Refer to INTCON and GPINTEN.

## 1.6.4 DEFAULT COMPARE (DEFVAL) REGISTER FOR INTERRUPT-ON-CHANGE

The default comparison value is configured in the DEFVAL register. If enabled (via GPINTEN and INTCON) to compare against the DEFVAL register, an opposite value on the associated pin will cause an interrupt to occur.

### REGISTER 1-4: DEFVAL – DEFAULT VALUE REGISTER (ADDR 0x03)

R/W-0	R/W-0	R/W-0	R/W-0	R/W-0	R/W-0	R/W-0	R/W-0
DEF7	DEF6	DEF5	DEF4	DEF3	DEF2	DEF1	DEF0
bit 7							bit 0

#### Legend:

R = Readable bit	W = Writable bit	U = Unimplemented bit, read as '0'
-n = Value at POR	'1' = Bit is set	'0' = Bit is cleared      x = Bit is unknown

bit 7-0      **DEF7:DEF0:** These bits set the compare value for pins configured for interrupt-on-change from defaults [7:0]. Refer to INTCON.

If the associated pin level is the opposite from the register bit, an interrupt occurs.

Refer to INTCON and GPINTEN.

## 1.6.5 INTERRUPT CONTROL (INTCON) REGISTER

The INTCON register controls how the associated pin value is compared for the interrupt-on-change feature. If a bit is set, the corresponding I/O pin is compared against the associated bit in the DEFVAL register. If a bit value is clear, the corresponding I/O pin is compared against the previous value.

### REGISTER 1-5: INTCON – INTERRUPT-ON-CHANGE CONTROL REGISTER (ADDR 0x04)

R/W-0	R/W-0	R/W-0	R/W-0	R/W-0	R/W-0	R/W-0	R/W-0
IOC7	IOC6	IOC5	IOC4	IOC3	IOC2	IOC1	IOC0
bit 7							bit 0

#### Legend:

R = Readable bit	W = Writable bit	U = Unimplemented bit, read as '0'
-n = Value at POR	'1' = Bit is set	'0' = Bit is cleared
		x = Bit is unknown

bit 7-0      **IOC7:IOC0:** These bits control how the associated pin value is compared for interrupt-on-change [7:0]  
 1 = Controls how the associated pin value is compared for interrupt-on-change  
 0 = Pin value is compared against the previous pin value

Refer to INTCON and GPINTEN.

# MCP23008/MCP23S08

## 1.6.6 CONFIGURATION (IOCON) REGISTER

The IOCON register contains several bits for configuring the device:

- The Sequential Operation (SEQOP) controls the incrementing function of the Address Pointer. If the Address Pointer is disabled, the Address Pointer does not automatically increment after each byte is clocked during a serial transfer. This feature is useful when it is desired to continuously poll (read) or modify (write) a register.
- The Slew Rate (DISSLW) bit controls the slew rate function on the SDA pin. If enabled, the SDA slew rate will be controlled when driving from a high to a low.
- The Hardware Address Enable (HAEN) control bit enables/disables the hardware address pins (A1, A0) on the MCP23S08. This bit is not used on the MCP23008. The address pins are always enabled on the MCP23008.
- The Open-Drain (ODR) control bit enables/disables the INT pin for open-drain configuration.
- The Interrupt Polarity (INTPOL) control bit sets the polarity of the INT pin. This bit is functional only when the ODR bit is cleared, configuring the INT pin as active push-pull.

### REGISTER 1-6: IOCON – I/O EXPANDER CONFIGURATION REGISTER (ADDR 0x05)

U-0	U-0	R/W-0	R/W-0	R/W-0	R/W-0	R/W-0	U-0
—	—	SEQOP	DISSLW	HAEN	ODR	INTPOL	—
bit 7							bit 0

#### Legend:

R = Readable bit	W = Writable bit	U = Unimplemented bit, read as '0'
-n = Value at POR	'1' = Bit is set	'0' = Bit is cleared
		x = Bit is unknown

- bit 7-6 **Unimplemented:** Read as '0'
- bit 5 **SEQOP:** Sequential Operation Mode
  - 1 = Sequential operation disabled, Address Pointer does not increment
  - 0 = Sequential operation enabled, Address Pointer increments
- bit 4 **DISSLW:** Slew Rate Control Bit for SDA Output
  - 1 = Slew rate disabled
  - 0 = Slew rate enabled
- bit 3 **HAEN:** Hardware Address Enable (MCP23S08 only)  
Address pins are always enabled on MCP23008.
  - 1 = Enables the MCP23S08 address pins
  - 0 = Disables the MCP23S08 address pins
- bit 2 **ODR:** This bit configures the INT pin as an open-drain output
  - 1 = Open-drain output (overrides the INTPOL bit)
  - 0 = Active driver output (INTPOL bit sets the polarity)
- bit 1 **INTPOL:** This bit sets the polarity of the INT output pin
  - 1 = Active-high
  - 0 = Active-low
- bit 0 **Unimplemented:** Read as '0'

## 1.6.7 PULL-UP RESISTOR CONFIGURATION (GPPU) REGISTER

The GPPU register controls the pull-up resistors for the PORT pins. If a bit is set and the corresponding pin is configured as an input, the corresponding PORT pin is internally pulled up with a 100 kΩ resistor.

### REGISTER 1-7: GPPU – GPIO PULL-UP RESISTOR REGISTER (ADDR 0x06)

R/W-0	R/W-0	R/W-0	R/W-0	R/W-0	R/W-0	R/W-0	R/W-0
PU7	PU6	PU5	PU4	PU3	PU2	PU1	PU0
bit 7							bit 0

#### Legend:

R = Readable bit	W = Writable bit	U = Unimplemented bit, read as '0'
-n = Value at POR	'1' = Bit is set	'0' = Bit is cleared      x = Bit is unknown

bit 7-0      **PU7:PU0:** These bits control the weak pull-up resistors on each pin (when configured as an input) [7:0]  
 1 = Pull-up enabled  
 0 = Pull-up disabled

## 1.6.8 INTERRUPT FLAG (INTF) REGISTER

The INTF register reflects the interrupt condition on the PORT pins of any pin that is enabled for interrupts via the GPINTEN register. A 'set' bit indicates that the associated pin caused the interrupt.

This register is 'read-only'. Writes to this register will be ignored.

**Note:** INTF will always reflect the pin(s) that have an interrupt condition. For example, one pin causes an interrupt to occur and is captured in INTCAP and INF. If before clearing the interrupt another pin changes, which would normally cause an interrupt, it will be reflected in INTF, but not INTCAP.

### REGISTER 1-8: INTF – INTERRUPT FLAG REGISTER (ADDR 0x07)

R-0	R-0	R-0	R-0	R-0	R-0	R-0	R-0
INT7	INT6	INT5	INT4	INT3	INT2	INT1	INT0
bit 7							bit 0

**Legend:**

R = Readable bit	W = Writable bit	U = Unimplemented bit, read as '0'
-n = Value at POR	'1' = Bit is set	'0' = Bit is cleared      x = Bit is unknown

bit 7-0      **INT7:INT0:** These bits reflect the interrupt condition on the port. Will reflect the change only if interrupts are enabled (GPINTEN) [7:0].

- 1 = Pin caused interrupt
- 0 = Interrupt not pending

## 1.6.9 INTERRUPT CAPTURE (INTCAP) REGISTER

The INTCAP register captures the GPIO port value at the time the interrupt occurred. The register is 'read-only' and is updated only when an interrupt occurs. The register will remain unchanged until the interrupt is cleared via a read of INTCAP or GPIO.

### REGISTER 1-9: INTCAP – INTERRUPT CAPTURED VALUE FOR PORT REGISTER (ADDR 0x08)

R-x	R-x	R-x	R-x	R-x	R-x	R-x	R-x
ICP7	ICP6	ICP5	ICP4	ICP3	ICP2	ICP1	ICP0
bit 7							bit 0

#### Legend:

R = Readable bit	W = Writable bit	U = Unimplemented bit, read as '0'
-n = Value at POR	'1' = Bit is set	'0' = Bit is cleared      x = Bit is unknown

bit 7-0      **ICP7:ICP0:** These bits reflect the logic level on the PORT pins at the time of interrupt due to pin change [7:0]  
 1 = Logic-high  
 0 = Logic-low

## 1.6.10 PORT (GPIO) REGISTER

The GPIO register reflects the value on the port. Reading from this register reads the port. Writing to this register modifies the Output Latch (OLAT) register.

### REGISTER 1-10: GPIO – GENERAL PURPOSE I/O PORT REGISTER (ADDR 0x09)

R/W-0	R/W-0	R/W-0	R/W-0	R/W-0	R/W-0	R/W-0	R/W-0
GP7	GP6	GP5	GP4	GP3	GP2	GP1	GP0
bit 7							bit 0

#### Legend:

R = Readable bit

W = Writable bit

U = Unimplemented bit, read as '0'

-n = Value at POR

'1' = Bit is set

'0' = Bit is cleared

x = Bit is unknown

bit 7-0

**GP7:GP0:** These bits reflect the logic level on the pins [7:0]

1 = Logic-high

0 = Logic-low

## 1.6.11 OUTPUT LATCH REGISTER (OLAT)

The OLAT register provides access to the output latches. A read from this register results in a read of the OLAT and not the port itself. A write to this register modifies the output latches that modify the pins configured as outputs.

### REGISTER 1-11: OLAT – OUTPUT LATCH REGISTER 0 (ADDR 0x0A)

R/W-0	R/W-0	R/W-0	R/W-0	R/W-0	R/W-0	R/W-0	R/W-0
OL7	OL6	OL5	OL4	OL3	OL2	OL1	OL0
bit 7							bit 0

#### Legend:

R = Readable bit

W = Writable bit

U = Unimplemented bit, read as '0'

-n = Value at POR

'1' = Bit is set

'0' = Bit is cleared

x = Bit is unknown

bit 7-0

**OL7:OL0:** These bits reflect the logic level on the output latch [7:0]

1 = Logic-high

0 = Logic-low

## 1.7 Interrupt Logic

The interrupt output pin will activate if an internal interrupt occurs. The interrupt block is configured by the following registers:

- GPINTEN – enables the individual inputs
- DEFVAL – holds the values that are compared against the associated input port values
- INTCON – controls if the input values are compared against DEFVAL or the previous values on the port
- IOCON (ODR and INPOL) – configures the INT pin as push-pull, open-drain and active-level

Only pins configured as inputs can cause interrupts. Pins configured as outputs have no effect on INT.

Interrupt activity on the port will cause the port value to be captured and copied into INTCAP. The interrupt will remain active until the INTCAP or GPIO register is read. Writing to these registers will not affect the interrupt.

The first interrupt event will cause the port contents to be copied into the INTCAP register. Subsequent interrupt conditions on the port will not cause an interrupt to occur as long as the interrupt is not cleared by a read of INTCAP or GPIO.

### 1.7.1 INTERRUPT CONDITIONS

There are two possible configurations to cause interrupts (configured via INTCON):

1. Pins configured for **interrupt-on-pin-change** will cause an interrupt to occur if a pin changes to the opposite state. The default state is reset after an interrupt occurs. For example, an interrupt occurs by an input changing from '1' to '0'. The new initial state for the pin is a logic '0'.
2. Pins configured for **interrupt-on-change from register value** will cause an interrupt to occur if the corresponding input pin differs from the register bit. The interrupt condition will remain as long as the condition exists, regardless if the INTAP or GPIO is read.

See [Figure 1-6](#) and [Figure 1-7](#) for more information on interrupt operations.

**FIGURE 1-7: INTERRUPT-ON-CHANGE FROM REGISTER DEFAULT**

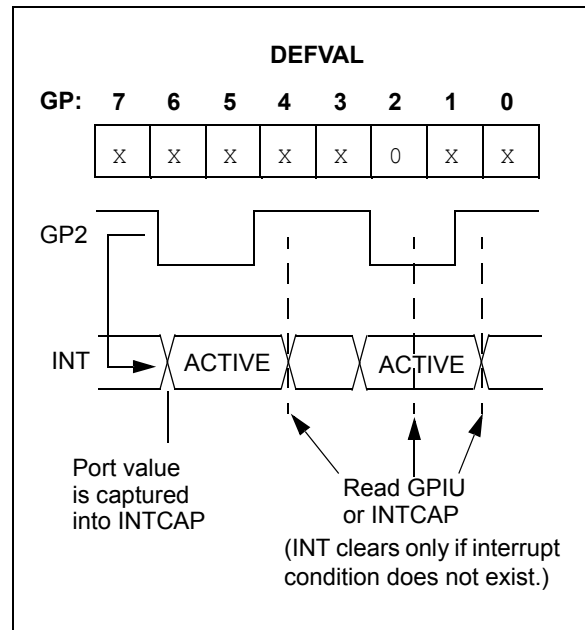

**FIGURE 1-6: INTERRUPT-ON-PIN-CHANGE**

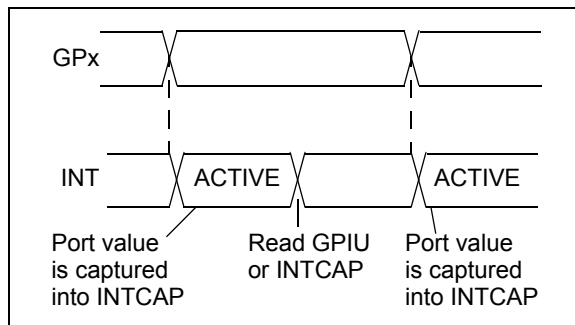

## 2.0 ELECTRICAL CHARACTERISTICS

### Absolute Maximum Ratings †

Ambient temperature under bias .....	-40°C to +125°C
Storage temperature .....	-65°C to +150°C
Voltage on VDD with respect to VSS .....	-0.3V to +5.5V
Voltage on all other pins with respect to VSS (except VDD).....	-0.6V to (VDD + 0.6V)
Total power dissipation ( <b>Note</b> ) .....	700 mW
Maximum current out of VSS pin .....	150 mA
Maximum current into VDD pin .....	125 mA
Input clamp current, I <sub>IK</sub> (V <sub>I</sub> < 0 or V <sub>I</sub> > VDD).....	±20 mA
Output clamp current, I <sub>OK</sub> (V <sub>O</sub> < 0 or V <sub>O</sub> > VDD).....	±20 mA
Maximum output current sunk by any output pin .....	25 mA
Maximum output current sourced by any output pin .....	25 mA

**Note:** Power dissipation is calculated as follows:  
 $P_{DIS} = V_{DD} \times \{I_{DD} - \sum I_{OH}\} + \sum \{(V_{DD} - V_{OH}) \times I_{OH}\} + \sum (V_{OL} \times I_{OL})$

† NOTICE: Stresses above those listed under “Absolute Maximum Ratings” may cause permanent damage to the device. This is a stress rating only and functional operation of the device at those or any other conditions above those indicated in the operation listings of this specification is not implied. Exposure to maximum rating conditions for extended periods may affect device reliability.

# MCP23008/MCP23S08

## 2.1 DC Characteristics

DC Characteristics		Operating Conditions (unless otherwise indicated): 1.8V ≤ VDD ≤ 5.5V at -40°C ≤ TA ≤ +85°C (I-Temp) 4.5V ≤ VDD ≤ 5.5V at -40°C ≤ TA ≤ +125°C (E-Temp) (Note 1)					
Param No.	Characteristic	Sym.	Min.	Typ.	Max.	Units	Conditions
D001	Supply Voltage	VDD	1.8	—	5.5	V	
D002	VDD Start Voltage to Ensure Power-on Reset	VPOR	—	VSS	—	V	
D003	VDD Rise Rate to Ensure Power-on Reset	SVDD	0.05	—	—	V/ms	Design guidance only. Not tested.
D004	Supply Current	IDD	—	—	1	mA	SCL/SCK = 1 MHz
D005	Standby current	IDDS	—	—	1	μA	
			—	—	2	μA	4.5V - 5.5V @ +125°C (Note 1)
<b>Input Low-Voltage</b>							
D030	A0, A1 (TTL buffer)	VIL	VSS	—	0.15 VDD	V	
D031	$\overline{CS}$ , GPIO, SCL/SCK, SDA, A2, $\overline{RESET}$ (Schmitt Trigger)		VSS	—	0.2 VDD	V	
<b>Input High-Voltage</b>							
D040	A0, A1 (TTL buffer)	VIH	0.25 VDD + 0.8	—	VDD	V	
D041	$\overline{CS}$ , GPIO, SCL/SCK, SDA, A2, $\overline{RESET}$ (Schmitt Trigger)		0.8 VDD	—	VDD	V	For entire VDD range.
<b>Input Leakage Current</b>							
D060	I/O PORT pins	IIL	—	—	±1	μA	VSS ≤ VPIN ≤ VDD
<b>Output Leakage Current</b>							
D065	I/O PORT pins	ILO	—	—	±1	μA	VSS ≤ VPIN ≤ VDD
D070	GPIO weak pull-up current	IPU	40	75	115	μA	VDD = 5V, GP Pins = VSS -40°C ≤ TA ≤ +85°C
<b>Output Low-Voltage</b>							
D080	GPIO	VOL	—	—	0.6	V	IOL = 8.5 mA, VDD = 4.5V
	INT		—	—	0.6	V	IOL = 1.6 mA, VDD = 4.5V
	SO, SDA		—	—	0.6	V	IOL = 3.0 mA, VDD = 1.8V
	SDA		—	—	0.8	V	IOL = 3.0 mA, VDD = 4.5V
<b>Output High-Voltage</b>							
D090	GPIO, INT, SO	VOH	VDD - 0.7	—	—	V	IOH = -3.0 mA, VDD = 4.5V
			VDD - 0.7	—	—		IOH = -400 μA, VDD = 1.8V
<b>Capacitive Loading Specs on Output Pins</b>							
D101	GPIO, SO, INT	CIO	—	—	50	pF	
D102	SDA	CB	—	—	400	pF	

**Note 1:** This parameter is characterized, not 100% tested.

**FIGURE 2-1: LOAD CONDITIONS FOR DEVICE TIMING SPECIFICATIONS**

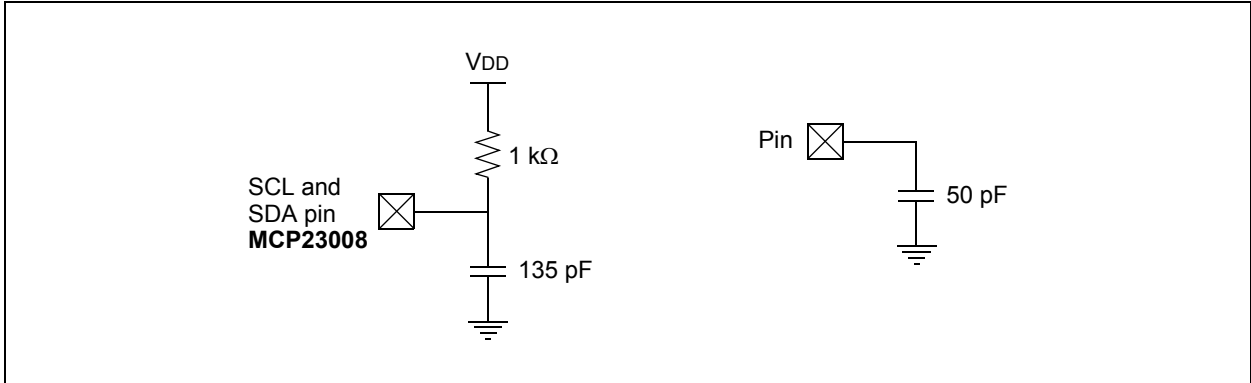

**FIGURE 2-2: RESET AND DEVICE RESET TIMER TIMING**

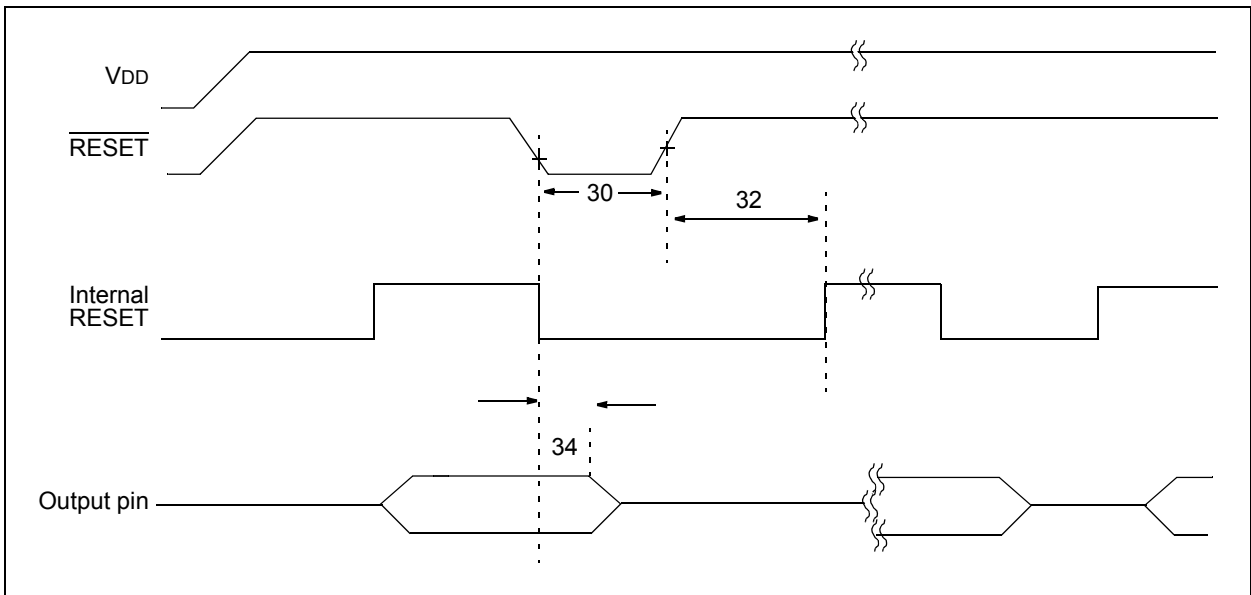
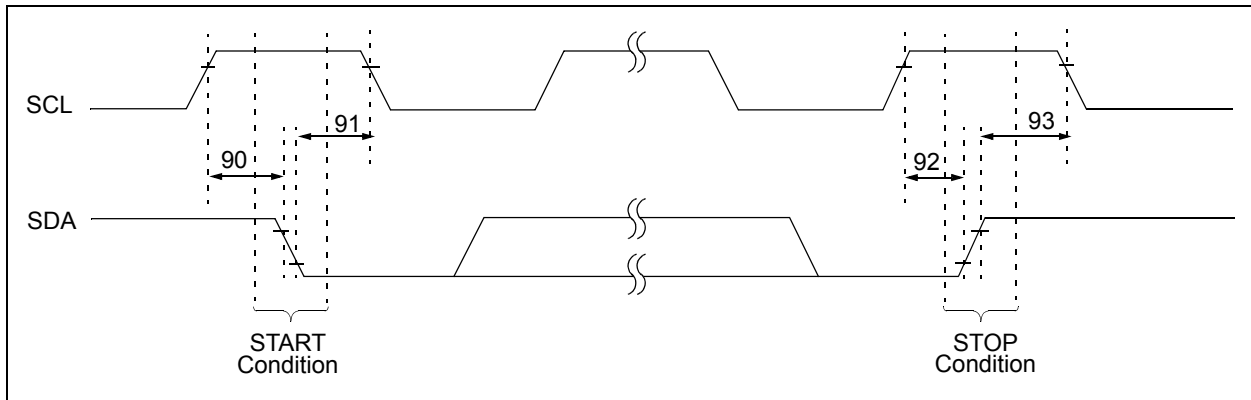

**TABLE 2-1: DEVICE RESET SPECIFICATIONS**

AC Characteristics		Operating Conditions (unless otherwise indicated): 1.8V ≤ VDD ≤ 5.5V at -40°C ≤ TA ≤ +85°C (I-Temp) 4.5V ≤ VDD ≤ 5.5V at -40°C ≤ TA ≤ +125°C (E-Temp) (Note 1)					
Param No.	Characteristic	Sym.	Min.	Typ. <sup>(1)</sup>	Max.	Units	Conditions
30	RESET Pulse Width (Low)	TRSTL	1	—	—	μs	
32	Device Active After RESET high	THLD	—	0	—	μs	VDD = 5.0V
34	Output High-Impedance from RESET Low	TIOZ	—	—	1	μs	

**Note 1:** This parameter is characterized, not 100% tested.

**FIGURE 2-3: I<sup>2</sup>C BUS START/STOP BITS TIMING**



**FIGURE 2-4: I<sup>2</sup>C BUS DATA TIMING**

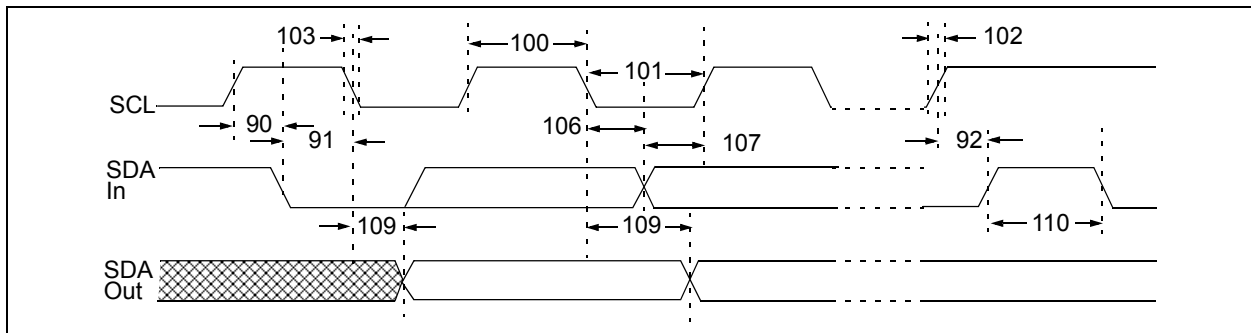

# MCP23008/MCP23S08

## I<sup>2</sup>C BUS DATA REQUIREMENTS

I <sup>2</sup> C AC Characteristics		Operating Conditions (unless otherwise indicated): 1.8V ≤ VDD ≤ 5.5V at -40°C ≤ TA ≤ +85°C (I-Temp) 4.5V ≤ VDD ≤ 5.5V at -40°C ≤ TA ≤ +125°C (E-Temp) (Note 1) RPU (SCL, SDA) = 1 kΩ, CL (SCL, SDA) = 135 pF					
Param No.	Characteristic	Sym.	Min.	Typ.	Max.	Units	Conditions
100	Clock High Time:	THIGH					
	100 kHz mode		4.0	—	—	μs	1.8V – 5.5V (I-Temp)
	400 kHz mode		0.6	—	—	μs	2.7V – 5.5V (I-Temp)
	1.7 MHz mode		0.12	—	—	μs	4.5V – 5.5V (E-Temp)
101	Clock Low Time:	TLOW					
	100 kHz mode		4.7	—	—	μs	1.8V – 5.5V (I-Temp)
	400 kHz mode		1.3	—	—	μs	2.7V – 5.5V (I-Temp)
	1.7 MHz mode		0.32	—	—	μs	4.5V – 5.5V (E-Temp)
102	SDA and SCL Rise Time:	TR (Note 1)					
	100 kHz mode		—	—	1000	ns	1.8V – 5.5V (I-Temp)
	400 kHz mode		20 + 0.1 CB <sup>(2)</sup>	—	300	ns	2.7V – 5.5V (I-Temp)
	1.7 MHz mode		20	—	160	ns	4.5V – 5.5V (E-Temp)
103	SDA and SCL Fall Time:	TF (Note 1)					
	100 kHz mode		—	—	300	ns	1.8V – 5.5V (I-Temp)
	400 kHz mode		20 + 0.1 CB <sup>(2)</sup>	—	300	ns	2.7V – 5.5V (I-Temp)
	1.7 MHz mode		20	—	80	ns	4.5V – 5.5V (E-Temp)
90	START Condition Setup Time:	TSU:STA					
	100 kHz mode		4.7	—	—	μs	1.8V – 5.5V (I-Temp)
	400 kHz mode		0.6	—	—	μs	2.7V – 5.5V (I-Temp)
	1.7 MHz mode		0.16	—	—	μs	4.5V – 5.5V (E-Temp)
91	START Condition Hold Time:	THD:STA					
	100 kHz mode		4.0	—	—	μs	1.8V – 5.5V (I-Temp)
	400 kHz mode		0.6	—	—	μs	2.7V – 5.5V (I-Temp)
	1.7 MHz mode		0.16	—	—	μs	4.5V – 5.5V (E-Temp)
106	Data Input Hold Time:	THD:DAT					
	100 kHz mode		0	—	3.45	μs	1.8V – 5.5V (I-Temp)
	400 kHz mode		0	—	0.9	μs	2.7V – 5.5V (I-Temp)
	1.7 MHz mode		0	—	0.15	μs	4.5V – 5.5V (E-Temp)
107	Data Input Setup Time:	TSU:DAT					
	100 kHz mode		250	—	—	ns	1.8V – 5.5V (I-Temp)
	400 kHz mode		100	—	—	ns	2.7V – 5.5V (I-Temp)
	1.7 MHz mode		0.01	—	—	μs	4.5V – 5.5V (E-Temp)
92	STOP Condition Setup Time:	TSU:STO					
	100 kHz mode		4.0	—	—	μs	1.8V – 5.5V (I-Temp)
	400 kHz mode		0.6	—	—	μs	2.7V – 5.5V (I-Temp)
	1.7 MHz mode		0.16	—	—	μs	4.5V – 5.5V (E-Temp)

**Note 1:** This parameter is characterized, not 100% tested.

**Note 2:** CB is specified to be from 10 to 400 pF.

# MCP23008/MCP23S08

## I<sup>2</sup>C BUS DATA REQUIREMENTS (CONTINUED)

I <sup>2</sup> C AC Characteristics		Operating Conditions (unless otherwise indicated): $1.8V \leq V_{DD} \leq 5.5V$ at $-40^{\circ}C \leq T_A \leq +85^{\circ}C$ (I-Temp) $4.5V \leq V_{DD} \leq 5.5V$ at $-40^{\circ}C \leq T_A \leq +125^{\circ}C$ (E-Temp) ( <b>Note 1</b> ) RPU (SCL, SDA) = 1 k $\Omega$ , CL (SCL, SDA) = 135 pF					
Param No.	Characteristic	Sym.	Min.	Typ.	Max.	Units	Conditions
109	Output Valid From Clock:	TAA					
	100 kHz mode		—	—	3.45	$\mu$ s	1.8V – 5.5V (I-Temp)
	400 kHz mode		—	—	0.9	$\mu$ s	2.7V – 5.5V (I-Temp)
	1.7 MHz mode		—	—	0.18	$\mu$ s	4.5V – 5.5V (E-Temp)
110	Bus Free Time:	TBUF					
	100 kHz mode		4.7	—	—	$\mu$ s	1.8V – 5.5V (I-Temp)
	400 kHz mode		1.3	—	—	$\mu$ s	2.7V – 5.5V (I-Temp)
	1.7 MHz mode		N/A	—	N/A	$\mu$ s	4.5V – 5.5V (E-Temp)
	Bus Capacitive Loading:	CB					
	100 kHz and 400 kHz		—	—	400	pF	( <b>Note 1</b> )
	1.7 MHz		—	—	100	pF	( <b>Note 1</b> )
	Input Filter Spike Suppression: (SDA and SCL)	TSP					
	100 kHz and 400 kHz		—	—	50	ns	
	1.7 MHz		—	—	10	ns	Spike suppression off

**Note 1:** This parameter is characterized, not 100% tested.

**Note 2:** CB is specified to be from 10 to 400 pF.

**FIGURE 2-5: SPI INPUT TIMING**

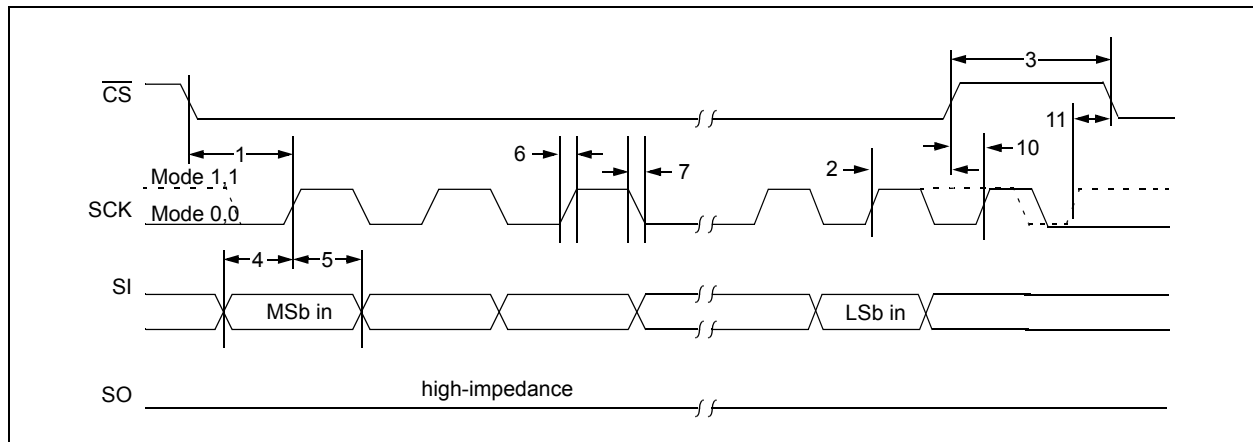

# MCP23008/MCP23S08

**FIGURE 2-6: SPI OUTPUT TIMING**

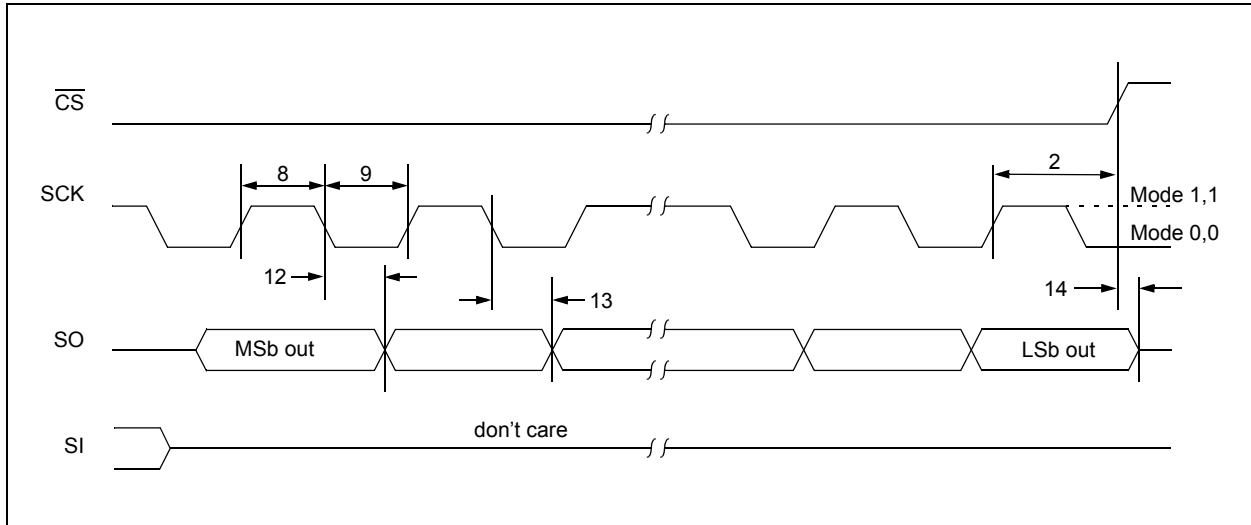

**TABLE 2-2: SPI INTERFACE AC CHARACTERISTICS**

SPI Interface AC Characteristics		Operating Conditions (unless otherwise indicated): 1.8V ≤ VDD ≤ 5.5V at -40°C ≤ TA ≤ +85°C (I-Temp) 4.5V ≤ VDD ≤ 5.5V at -40°C ≤ TA ≤ +125°C (E-Temp) (Note 1)					
Param No.	Characteristic	Sym.	Min.	Typ.	Max.	Units	Conditions
	Clock Frequency	FCLK	—	—	5	MHz	1.8V – 5.5V (I-Temp)
			—	—	10	MHz	2.7V – 5.5V (I-Temp)
			—	—	10	MHz	4.5V – 5.5V (E-Temp)
1	$\overline{CS}$ Setup Time	T <sub>CSS</sub>	50	—	—	ns	
2	$\overline{CS}$ Hold Time	T <sub>CSH</sub>	100	—	—	ns	1.8V – 5.5V (I-Temp)
			50	—	—	ns	2.7V – 5.5V (I-Temp)
			50	—	—	ns	4.5V – 5.5V (E-Temp)
3	$\overline{CS}$ Disable Time	T <sub>CSD</sub>	100	—	—	ns	1.8V – 5.5V (I-Temp)
			50	—	—	ns	2.7V – 5.5V (I-Temp)
			50	—	—	ns	4.5V – 5.5V (E-Temp)
4	Data Setup Time	T <sub>SU</sub>	20	—	—	ns	1.8V – 5.5V (I-Temp)
			10	—	—	ns	2.7V – 5.5V (I-Temp)
			10	—	—	ns	4.5V – 5.5V (E-Temp)
5	Data Hold Time	T <sub>HD</sub>	20	—	—	ns	1.8V – 5.5V (I-Temp)
			10	—	—	ns	2.7V – 5.5V (I-Temp)
			10	—	—	ns	4.5V – 5.5V (E-Temp)
6	CLK Rise Time	T <sub>R</sub>	—	—	2	μs	Note 1
7	CLK Fall Time	T <sub>F</sub>	—	—	2	μs	Note 1
8	Clock High Time	T <sub>HI</sub>	90	—	—	ns	1.8V – 5.5V (I-Temp)
			45	—	—	ns	2.7V – 5.5V (I-Temp)
			45	—	—	ns	4.5V – 5.5V (E-Temp)

**Note 1:** This parameter is characterized, not 100% tested.

**2:** T<sub>v</sub> = 90 ns (max) when Address Pointer rolls over from address 0x0A to 0x00.

**TABLE 2-2: SPI INTERFACE AC CHARACTERISTICS (CONTINUED)**

SPI Interface AC Characteristics		Operating Conditions (unless otherwise indicated): 1.8V ≤ VDD ≤ 5.5V at -40°C ≤ TA ≤ +85°C (I-Temp) 4.5V ≤ VDD ≤ 5.5V at -40°C ≤ TA ≤ +125°C (E-Temp) (Note 1)					
Param No.	Characteristic	Sym.	Min.	Typ.	Max.	Units	Conditions
9	Clock Low Time	TLO	90	—	—	ns	1.8V – 5.5V (I-Temp)
			45	—	—	ns	2.7V – 5.5V (I-Temp)
			45	—	—	ns	4.5V – 5.5V (E-Temp)
10	Clock Delay Time	TCLD	50	—	—	ns	
11	Clock Enable Time	TCLE	50	—	—	ns	
12 <sup>(2)</sup>	Output Valid from Clock Low	Tv	—	—	90	ns	1.8V – 5.5V (I-Temp)
			—	—	45	ns	2.7V – 5.5V (I-Temp)
			—	—	45	ns	4.5V – 5.5V (E-Temp)
13	Output Hold Time	THO	0	—	—	ns	
14	Output Disable Time	TDIS	—	—	100	ns	

**Note 1:** This parameter is characterized, not 100% tested.

**Note 2:** Tv = 90 ns (max) when Address Pointer rolls over from address 0x0A to 0x00.

**FIGURE 2-7: GPIO AND INT TIMING**

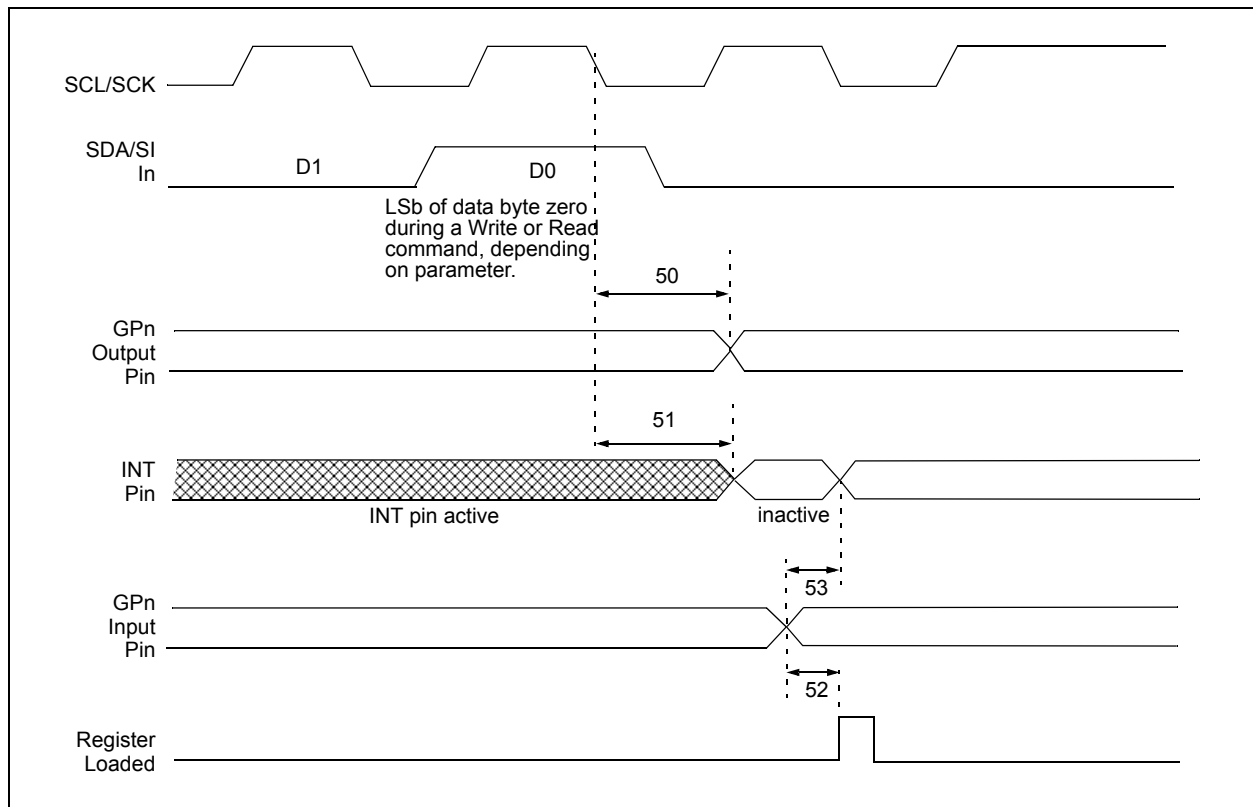

# MCP23008/MCP23S08

TABLE 2-3: GP AND INT PINS

AC Characteristics		Operating Conditions (unless otherwise indicated): 1.8V ≤ VDD ≤ 5.5V at -40°C ≤ TA ≤ +85°C (I-Temp) 4.5V ≤ VDD ≤ 5.5V at -40°C ≤ TA ≤ +125°C (E-Temp) (Note 1)					
Param No.	Characteristic	Sym.	Min.	Typ.	Max.	Units	Conditions
50	Serial data to output valid	TGPOV	—	—	500	ns	
51	Interrupt pin disable time	TINTD	—	—	600	ns	
52	GP input change to register valid	TGPIV	—	—	450	ns	
53	IOC event to INT active	TGPINT	—	—	600	ns	
	Glitch Filter on GP Pins	TGLITCH	—	—	150	ns	

**Note 1:** This parameter is characterized, not 100% tested

## 3.0 PACKAGING INFORMATION

### 3.1 Package Marking Information

18-Lead PDIP (300 mil)

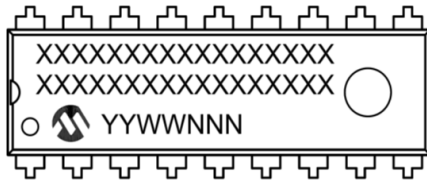

Example:

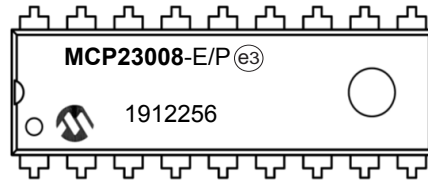

18-Lead SOIC (300 mil)

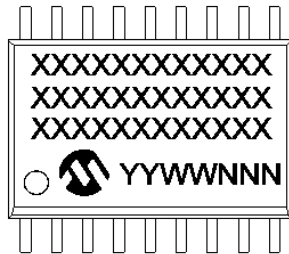

Example:

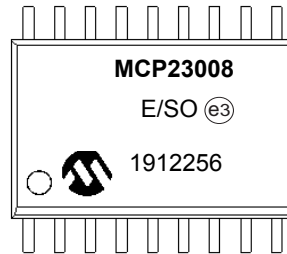

20-Lead QFN

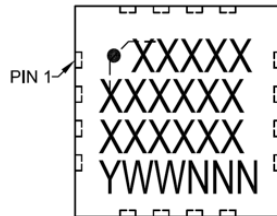

Example:

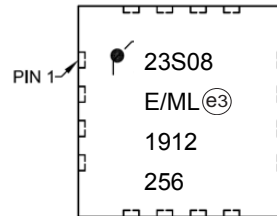

20-Lead SSOP

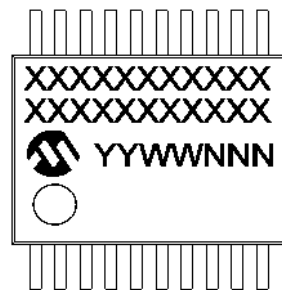

Example:

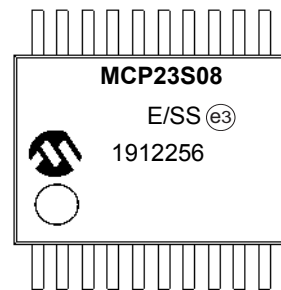

<b>Legend:</b>	XX...X	Customer-specific information
	Y	Year code (last digit of calendar year)
	YY	Year code (last 2 digits of calendar year)
	WW	Week code (week of January 1 is week '01')
	NNN	Alphanumeric traceability code
	(e3)	Pb-free JEDEC designator for Matte Tin (Sn)
	*	This package is Pb-free. The Pb-free JEDEC designator (e3) can be found on the outer packaging for this package.

**Note:** In the event the full Microchip part number cannot be marked on one line, it will be carried over to the next line, thus limiting the number of available characters for customer-specific information.

# MCP23008/MCP23S08

## 18-Lead Plastic Dual In-Line (P) – 300 mil Body [PDIP]

**Note:** For the most current package drawings, please see the Microchip Packaging Specification located at <http://www.microchip.com/packaging>

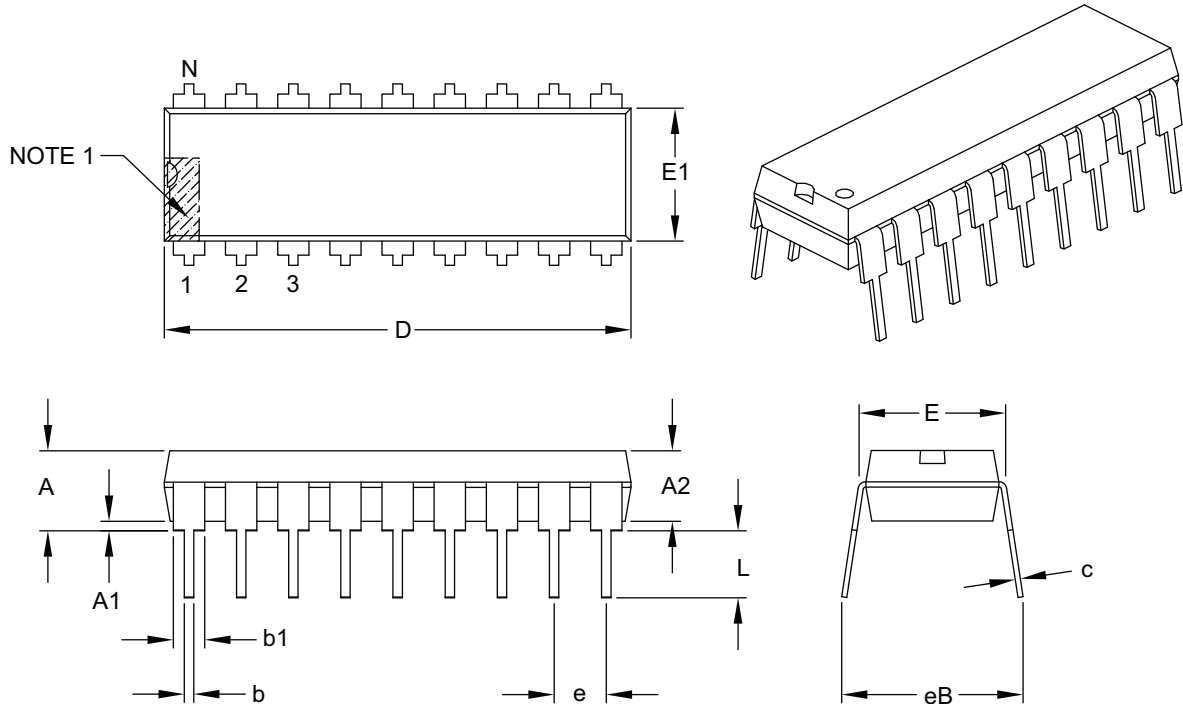

Dimension Limits	Units	INCHES		
		MIN	NOM	MAX
Number of Pins	N	18		
Pitch	e	.100 BSC		
Top to Seating Plane	A	–	–	.210
Molded Package Thickness	A2	.115	.130	.195
Base to Seating Plane	A1	.015	–	–
Shoulder to Shoulder Width	E	.300	.310	.325
Molded Package Width	E1	.240	.250	.280
Overall Length	D	.880	.900	.920
Tip to Seating Plane	L	.115	.130	.150
Lead Thickness	c	.008	.010	.014
Upper Lead Width	b1	.045	.060	.070
Lower Lead Width	b	.014	.018	.022
Overall Row Spacing §	eB	–	–	.430

**Notes:**

- Pin 1 visual index feature may vary, but must be located within the hatched area.
- § Significant Characteristic.
- Dimensions D and E1 do not include mold flash or protrusions. Mold flash or protrusions shall not exceed .010" per side.
- Dimensioning and tolerancing per ASME Y14.5M.

BSC: Basic Dimension. Theoretically exact value shown without tolerances.

Microchip Technology Drawing C04-007B

# MCP23008/MCP23S08

## 18-Lead Plastic Small Outline (SO) - Wide, 7.50 mm (.300 In.) Body [SOIC]

**Note:** For the most current package drawings, please see the Microchip Packaging Specification located at <http://www.microchip.com/packaging>

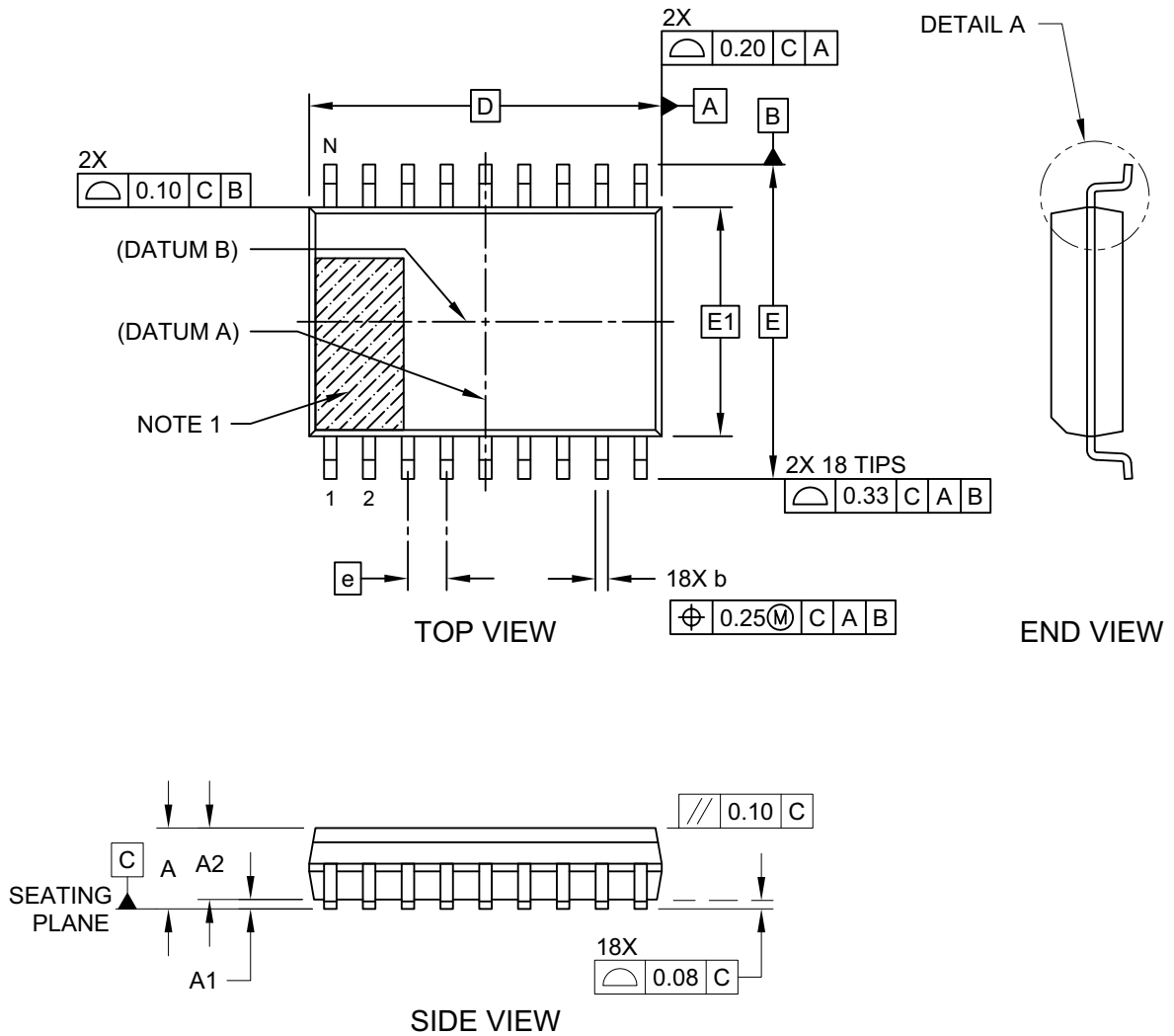

# MCP23008/MCP23S08

## 18-Lead Plastic Small Outline (SO) - Wide, 7.50 mm (.300 In.) Body [SOIC]

**Note:** For the most current package drawings, please see the Microchip Packaging Specification located at <http://www.microchip.com/packaging>

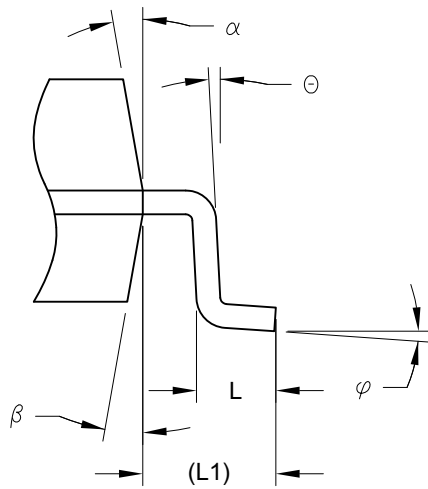

DETAIL A

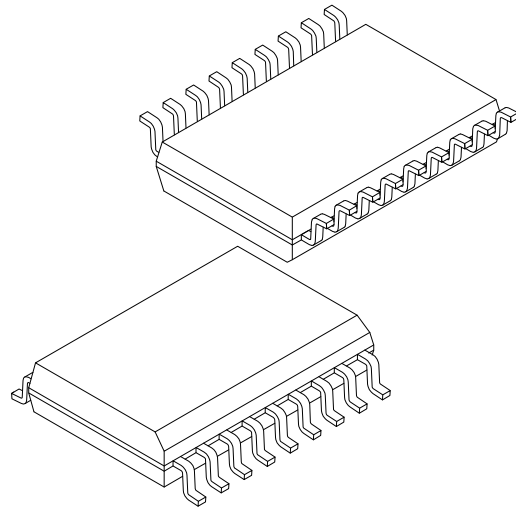

Units		MILLIMETERS		
Dimension Limits		MIN	NOM	MAX
Number of Pins	N	18		
Pitch	e	1.27 BSC		
Overall Height	A	-	-	2.65
Molded Package Thickness	A2	2.05	-	-
Standoff §	A1	0.10	-	0.30
Overall Width	E	10.30 BSC		
Molded Package Width	E1	7.50 BSC		
Overall Length	D	11.55 BSC		
Chamfer (Optional)	h	0.25	-	0.75
Foot Length	L	0.40	-	1.27
Footprint	L1	1.40 REF		
Lead Angle	Θ	0°	-	-
Foot Angle	φ	0°	-	8°
Lead Thickness	c	0.20	-	0.33
Lead Width	b	0.31	-	0.51
Mold Draft Angle Top	α	5°	-	15°
Mold Draft Angle Bottom	β	5°	-	15°

**Notes:**

- Pin 1 visual index feature may vary, but must be located within the hatched area.
- § Significant Characteristic
- Dimension D does not include mold flash, protrusions or gate burrs, which shall not exceed 0.15 mm per end. Dimension E1 does not include interlead flash or protrusion, which shall not exceed 0.25 mm per side.
- Dimensioning and tolerancing per ASME Y14.5M  
 BSC: Basic Dimension. Theoretically exact value shown without tolerances.  
 REF: Reference Dimension, usually without tolerance, for information purposes only.
- Datums A & B to be determined at Datum H.

Microchip Technology Drawing No. C04-051D Sheet 2 of 2

# MCP23008/MCP23S08

## 18-Lead Plastic Small Outline (SO) - Wide, 7.50 mm (.300 In.) Body [SOIC]

**Note:** For the most current package drawings, please see the Microchip Packaging Specification located at <http://www.microchip.com/packaging>

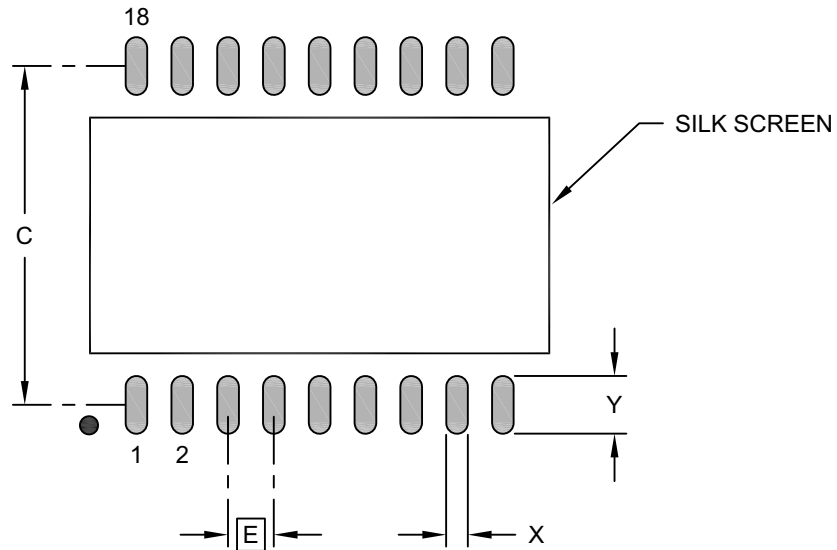

### RECOMMENDED LAND PATTERN

Dimension Limits	Units	MILLIMETERS		
		MIN	NOM	MAX
Contact Pitch	E	1.27 BSC		
Contact Pad Spacing	C		9.40	
Contact Pad Spacing				
Contact Pad Width (X18)	X			0.60
Contact Pad Length (X18)	Y			1.90

**Notes:**

1. Dimensioning and tolerancing per ASME Y14.5M  
BSC: Basic Dimension. Theoretically exact value shown without tolerances.

Microchip Technology Drawing C04-2051A

# MCP23008/MCP23S08

## 20-Lead Plastic Quad Flat, No Lead Package (ML) - 4x4 mm Body [QFN] Also called VQFN

**Note:** For the most current package drawings, please see the Microchip Packaging Specification located at <http://www.microchip.com/packaging>

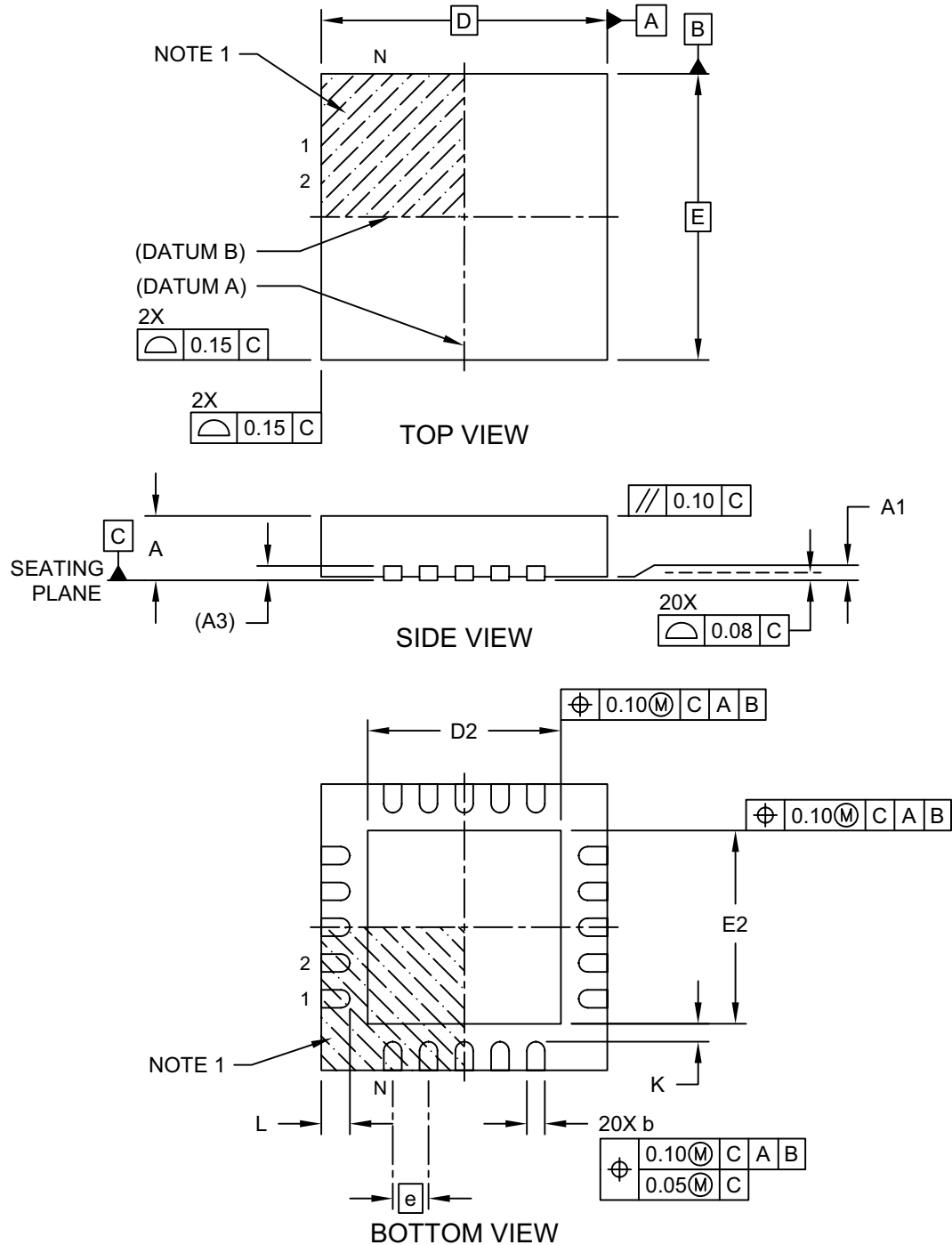

Microchip Technology Drawing C04-126 Rev C Sheet 1 of 2

# MCP23008/MCP23S08

## 20-Lead Plastic Quad Flat, No Lead Package (ML) - 4x4 mm Body [QFN] Also called VQFN

**Note:** For the most current package drawings, please see the Microchip Packaging Specification located at <http://www.microchip.com/packaging>

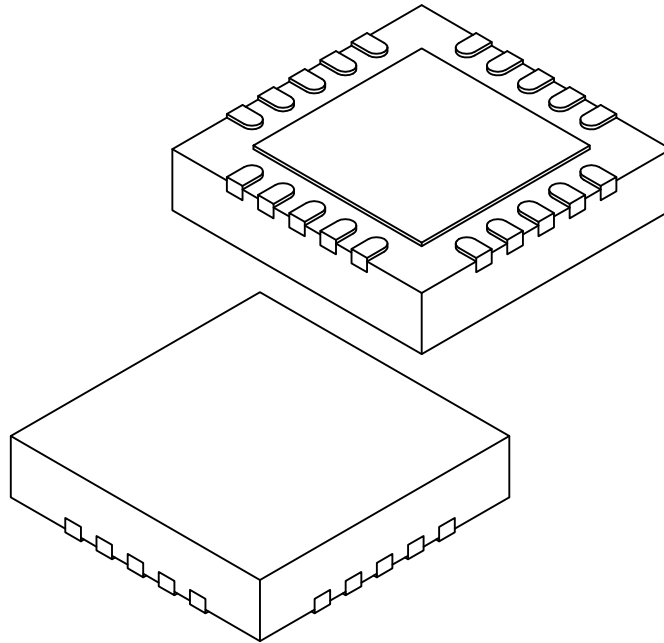

Dimension Limits	Units	MILLIMETERS		
		MIN	NOM	MAX
Number of Terminals	N	20		
Pitch	e	0.50 BSC		
Overall Height	A	0.80	0.90	1.00
Standoff	A1	0.00	0.02	0.05
Terminal Thickness	A3	0.20 REF		
Overall Length	D	4.00 BSC		
Exposed Pad Length	D2	2.60	2.70	2.80
Overall Width	E	4.00 BSC		
Exposed Pad Width	E2	2.60	2.70	2.80
Terminal Width	b	0.18	0.25	0.30
Terminal Length	L	0.30	0.40	0.50
Terminal-to-Exposed-Pad	K	0.20	-	-

**Notes:**

1. Pin 1 visual index feature may vary, but must be located within the hatched area.
2. Package is saw singulated
3. Dimensioning and tolerancing per ASME Y14.5M

BSC: Basic Dimension. Theoretically exact value shown without tolerances.

REF: Reference Dimension, usually without tolerance, for information purposes only.

Microchip Technology Drawing C04-126 Rev C Sheet 2 of 2

# MCP23008/MCP23S08

## 20-Lead Plastic Quad Flat, No Lead Package (ML) - 4x4 mm Body [QFN] Also called VQFN

**Note:** For the most current package drawings, please see the Microchip Packaging Specification located at <http://www.microchip.com/packaging>

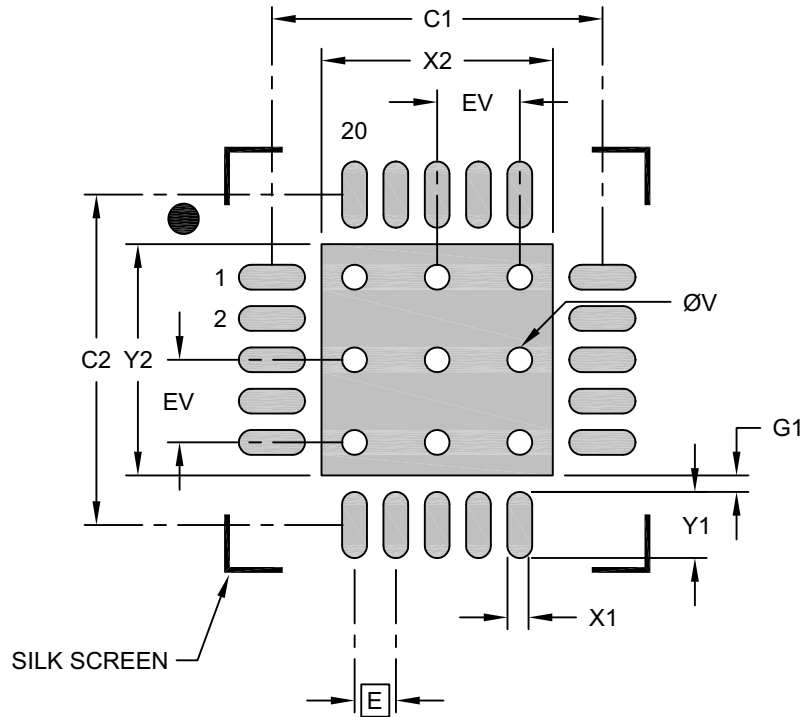

### RECOMMENDED LAND PATTERN

Dimension Limits	Units	MILLIMETERS		
		MIN	NOM	MAX
Contact Pitch	E	0.50 BSC		
Optional Center Pad Width	X2			2.80
Optional Center Pad Length	Y2			2.80
Contact Pad Spacing	C1		4.00	
Contact Pad Spacing	C2		4.00	
Contact Pad Width (X20)	X1			0.30
Contact Pad Length (X20)	Y1			0.80
Contact Pad to Center Pad (X16)	G1	0.20		
Thermal Via Diameter	V		0.30	
Thermal Via Pitch	EV		1.00	

**Notes:**

- Dimensioning and tolerancing per ASME Y14.5M  
BSC: Basic Dimension. Theoretically exact value shown without tolerances.
- For best soldering results, thermal vias, if used, should be filled or tented to avoid solder loss during reflow process

Microchip Technology Drawing C04-2126 Rev B

# MCP23008/MCP23S08

## 20-Lead Plastic Shrink Small Outline (SS) – 5.30 mm Body [SSOP]

**Note:** For the most current package drawings, please see the Microchip Packaging Specification located at <http://www.microchip.com/packaging>

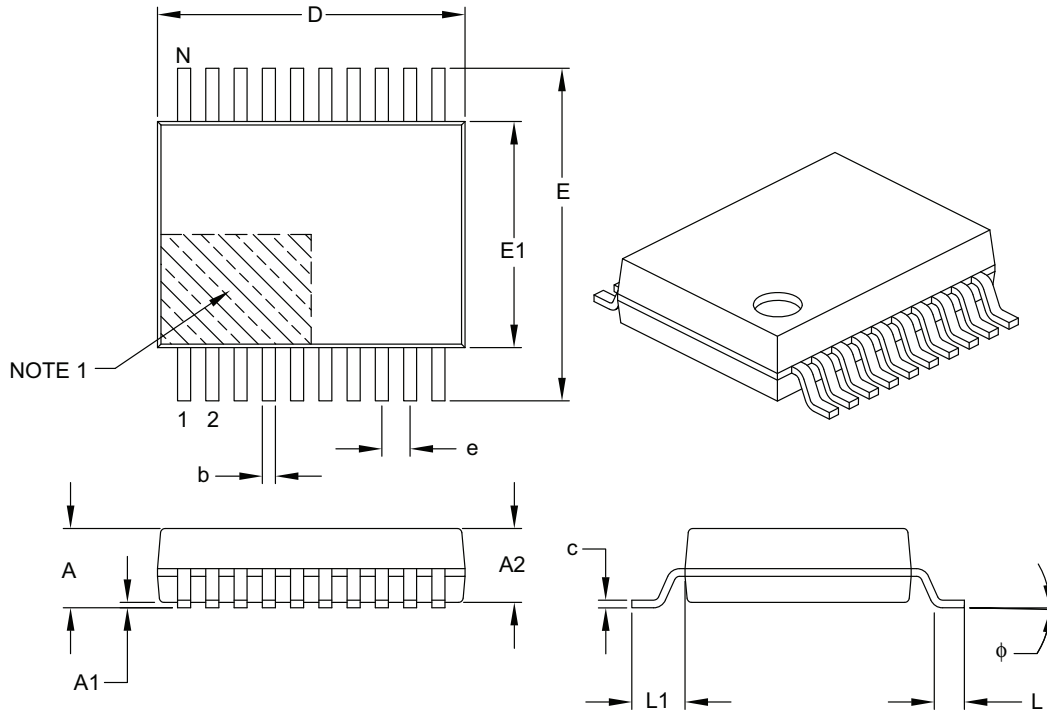

Dimension Limits	Units	MILLIMETERS		
		MIN	NOM	MAX
Number of Pins	N	20		
Pitch	e	0.65 BSC		
Overall Height	A	–	–	2.00
Molded Package Thickness	A2	1.65	1.75	1.85
Standoff	A1	0.05	–	–
Overall Width	E	7.40	7.80	8.20
Molded Package Width	E1	5.00	5.30	5.60
Overall Length	D	6.90	7.20	7.50
Foot Length	L	0.55	0.75	0.95
Footprint	L1	1.25 REF		
Lead Thickness	c	0.09	–	0.25
Foot Angle	$\phi$	0°	4°	8°
Lead Width	b	0.22	–	0.38

**Notes:**

- Pin 1 visual index feature may vary, but must be located within the hatched area.
- Dimensions D and E1 do not include mold flash or protrusions. Mold flash or protrusions shall not exceed 0.20 mm per side.
- Dimensioning and tolerancing per ASME Y14.5M.

BSC: Basic Dimension. Theoretically exact value shown without tolerances.

REF: Reference Dimension, usually without tolerance, for information purposes only.

Microchip Technology Drawing C04-072B

# MCP23008/MCP23S08

## 20-Lead Plastic Shrink Small Outline (SS) - 5.30 mm Body [SSOP]

**Note:** For the most current package drawings, please see the Microchip Packaging Specification located at <http://www.microchip.com/packaging>

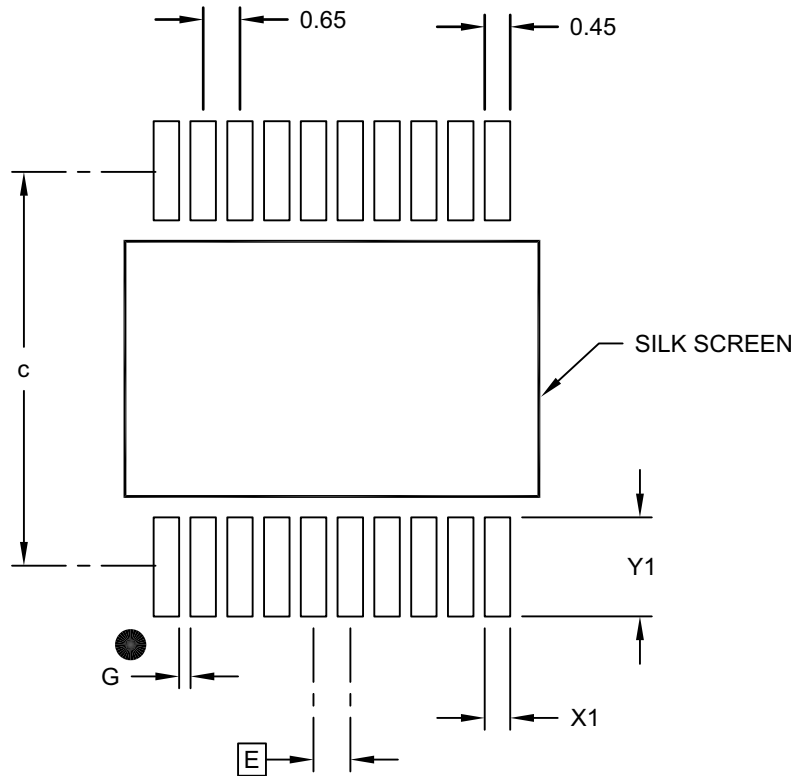

### RECOMMENDED LAND PATTERN

Dimension Limits	Units	MILLIMETERS		
		MIN	NOM	MAX
Contact Pitch	E	0.65 BSC		
Contact Pad Spacing	C		7.20	
Contact Pad Width (X20)	X1			0.45
Contact Pad Length (X20)	Y1			1.75
Distance Between Pads	G	0.20		

**Notes:**

1. Dimensioning and tolerancing per ASME Y14.5M

BSC: Basic Dimension. Theoretically exact value shown without tolerances.

Microchip Technology Drawing No. C04-2072B

## APPENDIX A: REVISION HISTORY

### Revision F (March 2019)

The following is the list of modifications:

1. Updated the QFN package drawing in [Section , Package Types](#).
2. Updated [Section 3.0 “Packaging Information”](#).
3. Minor typographical edits.

### Revision E (August 2007)

1. [Section 3.0 “Packaging Information”](#): Updated package outline drawings.

### Revision D (February 2007)

The following is the list of modifications:

1. Changed Byte and Sequential Read in [Figure 1-1](#) from “R” to “W”.
2. Table 2-4, Param No. 51 and 53: Changed from 450 to 600 and 500 to 600, respectively.
3. Added disclaimer to package outline drawings.
4. Updated package outline drawings.

### Revision C (October 2006)

The following is the list of modifications:

1. Added 20-pin QFN package information throughout document.
2. Added disclaimer to package outline drawings.

### Revision B (February 2005)

The following is the list of modifications:

1. [Section 1.6 “Configuration and Control Registers”](#). Added Hardware Address Enable (HAEN) bit to Table 1-3.
2. [Section 1.6.6 “Configuration \(IOCON\) Register”](#). Added Hardware Address Enable (HAEN) bit to Register 1-6.

### Revision A (December 2004)

Original Release of this Document.

# MCP23008/MCP23S08

## PRODUCT IDENTIFICATION SYSTEM

o order or obtain information, e.g., on pricing or delivery, refer to the factory or the listed sales office.

<u>PART NO.</u>	-	<u>X</u>	<u>/XX</u>	
Device		Temperature Range	Package	
<b>Device:</b>		MCP23008:	8-Bit I/O Expander w/ I <sup>2</sup> C Interface	
		MCP23008T:	8-Bit I/O Expander w/ I <sup>2</sup> C Interface (Tape and Reel)	
		MCP23S08:	8-Bit I/O Expander w/ SPI Interface	
		MCP23S08T:	8-Bit I/O Expander w/ SPI Interface (Tape and Reel)	
<b>Temperature Range:</b>		E	= -40°C to +125°C (Extended) *	
		* While these devices are only offered in the "E" temperature range, the device will operate at different voltages and temperatures as identified in <a href="#">Section 2.0 "Electrical Characteristics"</a> .		
<b>Package:</b>		ML	= Plastic Quad Flat, No Lead Package 4x4x0.9 mm Body (QFN), 20-Lead	
		P	= Plastic DIP (300 mil Body), 18-Lead	
		SO	= Plastic SOIC (300 mil Body), 18-Lead	
		SS	= SSOP, (209 mil Body, 5.30 mm), 20-Lead	
				<b>Examples:</b>
				a) MCP23008-E/P: Extended Temperature, 18LD PDIP package
				b) MCP23008-E/SO: Extended Temperature, 18LD SOIC package
				c) MCP23008T-E/SO: Tape and Reel, Extended Temperature, 18LD SOIC package
				d) MCP23008-E/SS: Extended Temperature, 20LD SSOP package
				e) MCP23008T-E/SS: Tape and Reel, Extended Temperature, 20LD SSOP package
				f) MCP23008-E/ML: Extended Temperature, 20LD QFN package
				a) MCP23S08-E/P: Extended Temperature, 18LD PDIP package
				b) MCP23S08-E/SO: Extended Temperature, 18LD SOIC package
				c) MCP23S08T-E/SO: Tape and Reel, Extended Temperature, 18LD SOIC package
				d) MCP23S08-E/SS: Extended Temperature, 20LD SSOP package
				e) MCP23S08T-E/SS: Tape and Reel, Extended Temperature, 20LD SSOP package
				f) MCP23S08T-E/MF: Tape and Reel, Extended Temperature,, 20LD QFN package

---

---

**Note the following details of the code protection feature on Microchip devices:**

- Microchip products meet the specification contained in their particular Microchip Data Sheet.
- Microchip believes that its family of products is one of the most secure families of its kind on the market today, when used in the intended manner and under normal conditions.
- There are dishonest and possibly illegal methods used to breach the code protection feature. All of these methods, to our knowledge, require using the Microchip products in a manner outside the operating specifications contained in Microchip's Data Sheets. Most likely, the person doing so is engaged in theft of intellectual property.
- Microchip is willing to work with the customer who is concerned about the integrity of their code.
- Neither Microchip nor any other semiconductor manufacturer can guarantee the security of their code. Code protection does not mean that we are guaranteeing the product as “unbreakable.”

Code protection is constantly evolving. We at Microchip are committed to continuously improving the code protection features of our products. Attempts to break Microchip's code protection feature may be a violation of the Digital Millennium Copyright Act. If such acts allow unauthorized access to your software or other copyrighted work, you may have a right to sue for relief under that Act.

---

Information contained in this publication regarding device applications and the like is provided only for your convenience and may be superseded by updates. It is your responsibility to ensure that your application meets with your specifications. MICROCHIP MAKES NO REPRESENTATIONS OR WARRANTIES OF ANY KIND WHETHER EXPRESS OR IMPLIED, WRITTEN OR ORAL, STATUTORY OR OTHERWISE, RELATED TO THE INFORMATION, INCLUDING BUT NOT LIMITED TO ITS CONDITION, QUALITY, PERFORMANCE, MERCHANTABILITY OR FITNESS FOR PURPOSE. Microchip disclaims all liability arising from this information and its use. Use of Microchip devices in life support and/or safety applications is entirely at the buyer's risk, and the buyer agrees to defend, indemnify and hold harmless Microchip from any and all damages, claims, suits, or expenses resulting from such use. No licenses are conveyed, implicitly or otherwise, under any Microchip intellectual property rights unless otherwise stated.

*Microchip received ISO/TS-16949:2009 certification for its worldwide headquarters, design and wafer fabrication facilities in Chandler and Tempe, Arizona; Gresham, Oregon and design centers in California and India. The Company's quality system processes and procedures are for its PIC® MCUs and dsPIC® DSCs, KEELOQ® code hopping devices, Serial EEPROMs, microperipherals, nonvolatile memory and analog products. In addition, Microchip's quality system for the design and manufacture of development systems is ISO 9001:2000 certified.*

**QUALITY MANAGEMENT SYSTEM  
CERTIFIED BY DNV  
= ISO/TS 16949 =**

### Trademarks

The Microchip name and logo, the Microchip logo, AnyRate, AVR, AVR logo, AVR Freaks, BitCloud, chipKIT, chipKIT logo, CryptoMemory, CryptoRF, dsPIC, FlashFlex, flexPWR, Helder, JukeBlox, KeeLoq, Klear, LANCheck, LINK MD, maXStylus, maXTouch, MediaLB, megaAVR, MOST, MOST logo, MPLAB, OptoLyzer, PIC, picoPower, PICSTART, PIC32 logo, Prochip Designer, QTouch, SAM-BA, SpyNIC, SST, SST Logo, SuperFlash, tinyAVR, UNI/O, and XMEGA are registered trademarks of Microchip Technology Incorporated in the U.S.A. and other countries.

ClockWorks, The Embedded Control Solutions Company, EtherSynch, Hyper Speed Control, HyperLight Load, IntelliMOS, mTouch, Precision Edge, and Quiet-Wire are registered trademarks of Microchip Technology Incorporated in the U.S.A.

Adjacent Key Suppression, AKS, Analog-for-the-Digital Age, Any Capacitor, AnyIn, AnyOut, BodyCom, CodeGuard, CryptoAuthentication, CryptoAutomotive, CryptoCompanion, CryptoController, dsPICDEM, dsPICDEM.net, Dynamic Average Matching, DAM, ECAN, EtherGREEN, In-Circuit Serial Programming, ICSP, INICnet, Inter-Chip Connectivity, JitterBlocker, KlearNet, KlearNet logo, memBrain, Mindi, MiWi, motorBench, MPASM, MPF, MPLAB Certified logo, MPLIB, MPLINK, MultiTRAK, NetDetach, Omniscient Code Generation, PICDEM, PICDEM.net, PICkit, PICtail, PowerSmart, PureSilicon, QMatrix, REAL ICE, Ripple Blocker, SAM-ICE, Serial Quad I/O, SMART-I.S., SQI, SuperSwitcher, SuperSwitcher II, Total Endurance, TSHARC, USBCheck, VariSense, ViewSpan, WiperLock, Wireless DNA, and ZENA are trademarks of Microchip Technology Incorporated in the U.S.A. and other countries.

SQTP is a service mark of Microchip Technology Incorporated in the U.S.A.

Silicon Storage Technology is a registered trademark of Microchip Technology Inc. in other countries.

GestIC is a registered trademark of Microchip Technology Germany II GmbH & Co. KG, a subsidiary of Microchip Technology Inc., in other countries.

All other trademarks mentioned herein are property of their respective companies.

© 2018, Microchip Technology Incorporated, All Rights Reserved.  
ISBN: 978-1-5224-4342-1



# MICROCHIP

## Worldwide Sales and Service

### AMERICAS

**Corporate Office**  
2355 West Chandler Blvd.  
Chandler, AZ 85224-6199  
Tel: 480-792-7200  
Fax: 480-792-7277  
Technical Support:  
<http://www.microchip.com/support>  
Web Address:  
[www.microchip.com](http://www.microchip.com)

#### Atlanta

Duluth, GA  
Tel: 678-957-9614  
Fax: 678-957-1455

#### Austin, TX

Tel: 512-257-3370

#### Boston

Westborough, MA  
Tel: 774-760-0087  
Fax: 774-760-0088

#### Chicago

Itasca, IL  
Tel: 630-285-0071  
Fax: 630-285-0075

#### Dallas

Addison, TX  
Tel: 972-818-7423  
Fax: 972-818-2924

#### Detroit

Novi, MI  
Tel: 248-848-4000

#### Houston, TX

Tel: 281-894-5983

#### Indianapolis

Noblesville, IN  
Tel: 317-773-8323  
Fax: 317-773-5453  
Tel: 317-536-2380

#### Los Angeles

Mission Viejo, CA  
Tel: 949-462-9523  
Fax: 949-462-9608  
Tel: 951-273-7800

#### Raleigh, NC

Tel: 919-844-7510

#### New York, NY

Tel: 631-435-6000

#### San Jose, CA

Tel: 408-735-9110  
Tel: 408-436-4270

#### Canada - Toronto

Tel: 905-695-1980  
Fax: 905-695-2078

### ASIA/PACIFIC

**Australia - Sydney**  
Tel: 61-2-9868-6733

**China - Beijing**  
Tel: 86-10-8569-7000

**China - Chengdu**  
Tel: 86-28-8665-5511

**China - Chongqing**  
Tel: 86-23-8980-9588

**China - Dongguan**  
Tel: 86-769-8702-9880

**China - Guangzhou**  
Tel: 86-20-8755-8029

**China - Hangzhou**  
Tel: 86-571-8792-8115

**China - Hong Kong SAR**  
Tel: 852-2943-5100

**China - Nanjing**  
Tel: 86-25-8473-2460

**China - Qingdao**  
Tel: 86-532-8502-7355

**China - Shanghai**  
Tel: 86-21-3326-8000

**China - Shenyang**  
Tel: 86-24-2334-2829

**China - Shenzhen**  
Tel: 86-755-8864-2200

**China - Suzhou**  
Tel: 86-186-6233-1526

**China - Wuhan**  
Tel: 86-27-5980-5300

**China - Xian**  
Tel: 86-29-8833-7252

**China - Xiamen**  
Tel: 86-592-2388138

**China - Zhuhai**  
Tel: 86-756-3210040

### ASIA/PACIFIC

**India - Bangalore**  
Tel: 91-80-3090-4444

**India - New Delhi**  
Tel: 91-11-4160-8631

**India - Pune**  
Tel: 91-20-4121-0141

**Japan - Osaka**  
Tel: 81-6-6152-7160

**Japan - Tokyo**  
Tel: 81-3-6880-3770

**Korea - Daegu**  
Tel: 82-53-744-4301

**Korea - Seoul**  
Tel: 82-2-554-7200

**Malaysia - Kuala Lumpur**  
Tel: 60-3-7651-7906

**Malaysia - Penang**  
Tel: 60-4-227-8870

**Philippines - Manila**  
Tel: 63-2-634-9065

**Singapore**  
Tel: 65-6334-8870

**Taiwan - Hsin Chu**  
Tel: 886-3-577-8366

**Taiwan - Kaohsiung**  
Tel: 886-7-213-7830

**Taiwan - Taipei**  
Tel: 886-2-2508-8600

**Thailand - Bangkok**  
Tel: 66-2-694-1351

**Vietnam - Ho Chi Minh**  
Tel: 84-28-5448-2100

### EUROPE

**Austria - Wels**  
Tel: 43-7242-2244-39  
Fax: 43-7242-2244-393

**Denmark - Copenhagen**  
Tel: 45-4450-2828  
Fax: 45-4485-2829

**Finland - Espoo**  
Tel: 358-9-4520-820

**France - Paris**  
Tel: 33-1-69-53-63-20  
Fax: 33-1-69-30-90-79

**Germany - Garching**  
Tel: 49-8931-9700

**Germany - Haan**  
Tel: 49-2129-3766400

**Germany - Heilbronn**  
Tel: 49-7131-67-3636

**Germany - Karlsruhe**  
Tel: 49-721-625370

**Germany - Munich**  
Tel: 49-89-627-144-0  
Fax: 49-89-627-144-44

**Germany - Rosenheim**  
Tel: 49-8031-354-560

**Israel - Ra'anana**  
Tel: 972-9-744-7705

**Italy - Milan**  
Tel: 39-0331-742611  
Fax: 39-0331-466781

**Italy - Padova**  
Tel: 39-049-7625286

**Netherlands - Drunen**  
Tel: 31-416-690399  
Fax: 31-416-690340

**Norway - Trondheim**  
Tel: 47-7288-4388

**Poland - Warsaw**  
Tel: 48-22-3325737

**Romania - Bucharest**  
Tel: 40-21-407-87-50

**Spain - Madrid**  
Tel: 34-91-708-08-90  
Fax: 34-91-708-08-91



**Sweden - Gothenberg**  
Tel: 46-31-704-60-40

**Sweden - Stockholm**  
Tel: 46-8-5090-4654

**UK - Wokingham**  
Tel: 44-118-921-5800  
Fax: 44-118-921-5820

## Looking for pricing, stock, or lifecycle information?

Click below to explore more details on WIN SOURCE:

-  [View MCP23S08T-E/SO on WIN SOURCE](#)
-  [Microchip Technology](#) Information

## Optimize Your Supply Chain with WIN SOURCE Solutions

-  Global Sourcing Solution
-  Obsolete Management
-  Cost Control Management
-  Shortage Management
-  Alternative Solution
-  Excess Inventory Management