



**THE DATASHEET OF
AS6C8016A-55ZIN**





512K X 16 BIT LOW POWER CMOS SRAM

FEATURES

- Process Technology : 0.15 μ m Full CMOS
- Organization : 512K x 16 bit
- Power Supply Voltage : 2.7V ~ 3.6V
- Low Data Retention Voltage : 1.5V(Min.)
- Three state output and TTL Compatible
- Package Type : 48-FPBGA, 44-TSOP2

GENERAL DESCRIPTION

The AS6C8016A is fabricated by Alliance 's advanced full CMOS process technology. The families support industrial temperature range and Chip Scale Package for user flexibility of system design. The families also support low data retention voltage for battery back-up operation with low data retention current.

PRODUCT FAMILY

	Operating Temperature	Vcc Range	Speed	Power Dissipation		PKG Type
				Standby (I _{SB1} , Typ.)	Operating (I _{CC1} -Max.)	
AS6C8016A	Industrial (-40 ~ 85°C)	2.7 ~ 3.6 V	55 ns	2 μ A ¹⁾	4 mA	KGD
AS6C8016A-55BIN						48-FPBGA
AS6C8016A-55ZIN						44-TSOP2

1. Typical values are measured at Vcc=3.3V, T_A=25°C and not 100% tested.

FUNCTIONAL BLOCK DIAGRAM

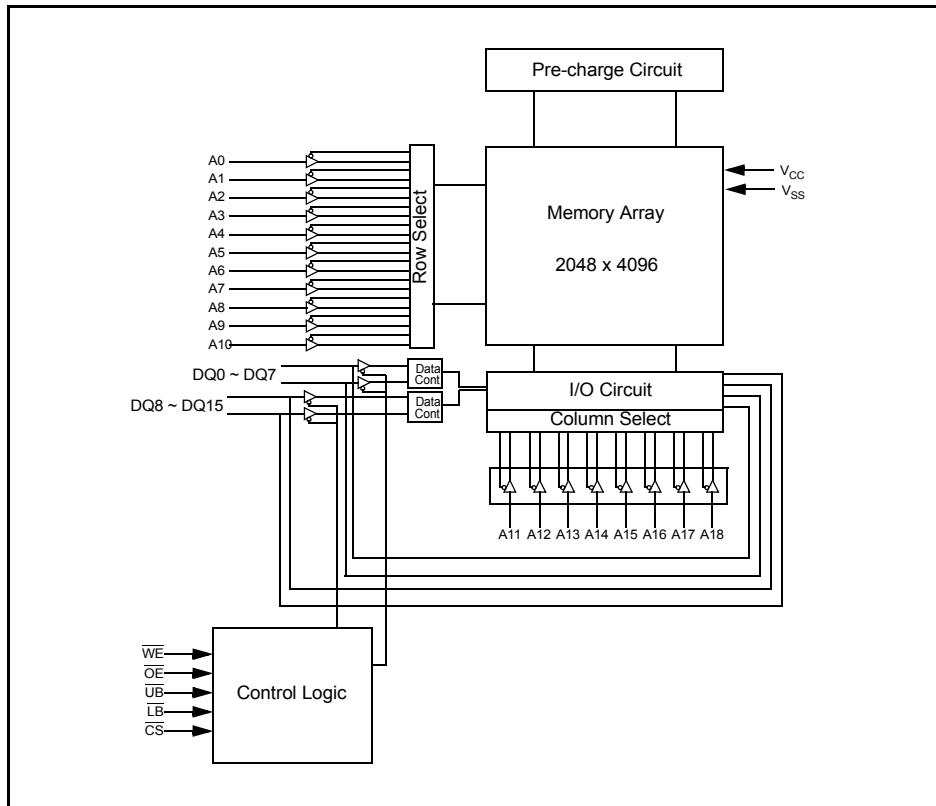



512K X 16 BIT LOW POWER CMOS SRAM

PIN CONFIGURATIONS

FPBGA-48 : Top view(ball down)

	1	2	3	4	5	6
A	$\overline{\text{LB}}$	$\overline{\text{OE}}$	A0	A1	A2	NC
B	DQ8	$\overline{\text{UB}}$	A3	A4	$\overline{\text{CS}}$	DQ0
C	DQ9	DQ10	A5	A6	DQ1	DQ2
D	V _{SS}	DQ11	A17	A7	DQ3	V _{CC}
E	V _{CC}	DQ12	NC	A16	DQ4	V _{SS}
F	DQ14	DQ13	A14	A15	DQ5	DQ6
G	DQ15	NC	A12	A13	$\overline{\text{WE}}$	DQ7
H	A18	A8	A9	A10	A11	NC

44 - TSOP2 : Top view

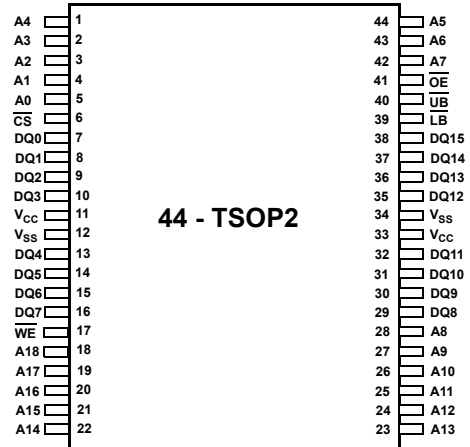

PIN DESCRIPTION

	Function	Name	Function
$\overline{\text{CS}}$	Chip Select input	V _{CC}	Power Supply
$\overline{\text{OE}}$	Output Enable input	V _{SS}	Ground
$\overline{\text{WE}}$	Write Enable input	$\overline{\text{UB}}$	Upper Byte (DQ8~DQ15)
A0~A18	Address inputs	$\overline{\text{LB}}$	Lower Byte (DQ0~DQ7)
DQ0~DQ15	Data inputs/outputs	NC	No Connection



512K X 16 BIT LOW POWER CMOS SRAM

ABSOLUTE MAXIMUM RATINGS¹⁾

	Symbol	Ratings	Unit
Voltage on Any Pin Relative to V _{SS}	V _{IN} , V _{OUT}	-0.2 to 4.0	V
Voltage on V _{CC} supply relative to V _{SS}	V _{CC}	-0.2 to 4.0	V
Power Dissipation	P _D	1.0	W
Operating Temperature	T _A	-40 to 85	°C

1. Stresses greater than those listed under "Absolute Maximum Ratings" may cause permanent damage to the device. Functional operation should be restricted to recommended operating condition. Exposure to absolute maximum rating conditions for extended periods may affect reliability.

FUNCTIONAL DESCRIPTION

$\overline{\text{CS}}$	$\overline{\text{OE}}$	$\overline{\text{WE}}$	$\overline{\text{LB}}$	$\overline{\text{UB}}$	DQ0~7	DQ8~15	Mode	Power
H	X	X	X	X	High-Z	High-Z	Deselected	Stand by
X	X	X	H	H	High-Z	High-Z	Deselected	Stand by
L	H	H	L	X	High-Z	High-Z	Output Disabled	Active
L	H	H	X	L	High-Z	High-Z	Output Disabled	Active
L	L	H	L	H	Data Out	High-Z	Lower Byte Read	Active
L	L	H	H	L	High-Z	Data Out	Upper Byte Read	Active
L	L	H	L	L	Data Out	Data Out	Word Read	Active
L	X	L	L	H	Data In	High-Z	Lower Byte Write	Active
L	X	L	H	L	High-Z	Data In	Upper Byte Write	Active
L	X	L	L	L	Data In	Data In	Word Write	Active

NOTE : X means don't care. (Must be low or high state)



512K X 16 BIT LOW POWER CMOS SRAM

RECOMMENDED DC OPERATING CONDITIONS ¹⁾

	Symbol	Min	Typ	Max	Unit
Supply voltage	V_{CC}	2.7	3.3	3.6	V
Ground	V_{SS}	0	0	0	V
Input high voltage	V_{IH}	2.2	-	$V_{CC} + 0.2^{2)}$	V
Input low voltage	V_{IL}	-0.2 ³⁾	-	0.6	V

1. $T_A = -40$ to 85°C , otherwise specified
2. Overshoot: $V_{CC} + 2.0$ V in case of pulse width ≤ 20 ns
3. Undershoot: -2.0 V in case of pulse width ≤ 20 ns
4. Overshoot and undershoot are sampled, not 100% tested.

CAPACITANCE ¹⁾ ($f = 1\text{MHz}$, $T_A = 25^\circ\text{C}$)

Item	Symbol	Test Condition	Min	Max	Unit
Input capacitance	C_{IN}	$V_{IN} = 0\text{V}$	-	8	pF
Input/Output capacitance	C_{IO}	$V_{IO} = 0\text{V}$	-	10	pF

1. Capacitance is sampled, not 100% tested

DC AND OPERATING CHARACTERISTICS

Parameter	Symbol	Test Conditions	Min	Typ	Max	Unit
Input leakage current	I_{LI}	$V_{IN} = V_{SS}$ to V_{CC}	-1	-	1	μA
Output leakage current	I_{LO}	$\overline{CS} = V_{IH}$ or $\overline{OE} = V_{IH}$ or $\overline{WE} = V_{IL}$ or $\overline{LB} = \overline{UB} = V_{IH}$ $V_{IO} = V_{SS}$ to V_{CC}	-1	-	1	μA
Operating power supply	I_{CC}	$I_{IO} = 0\text{mA}$, $\overline{CS} = V_{IL}$, $\overline{WE} = V_{IH}$, $V_{IN} = V_{IH}$ or V_{IL}	-	-	2	mA
Average operating current	I_{CC1}	Cycle time = $1\mu\text{s}$, 100% duty, $I_{IO} = 0\text{mA}$, $\overline{CS} \leq 0.2\text{V}$, $\overline{LB} \leq 0.2\text{V}$ or/and $\overline{UB} \leq 0.2\text{V}$, $V_{IN} \leq 0.2\text{V}$ or $V_{IN} \geq V_{CC} - 0.2\text{V}$	-	-	4	mA
	I_{CC2}	Cycle time = Min, $I_{IO} = 0\text{mA}$, 100% duty, $\overline{CS} = V_{IL}$, $\overline{LB} = V_{IL}$ or/and $\overline{UB} = V_{IL}$, $V_{IN} = V_{IL}$ or V_{IH}	55ns	-	35	mA
Output low voltage	V_{OL}	$I_{OL} = 2.1\text{mA}$	-	-	0.4	V
Output high voltage	V_{OH}	$I_{OH} = -1.0\text{mA}$	2.4	-	-	V
Standby Current (TTL)	I_{SB}	$\overline{CS} = V_{IH}$, Other inputs = V_{IH} or V_{IL}	-	-	0.5	mA
Standby Current (CMOS)	I_{SB1}	$\overline{CS} \geq V_{CC} - 0.2\text{V}$, Other inputs = $0 \sim V_{CC}$ (Typ. condition : $V_{CC} = 3.3\text{V}$ @ 25°C) (Max. condition : $V_{CC} = 3.6\text{V}$ @ 85°C)	LF	-	2 ¹⁾	15 μA

1. Typical values are measured at $V_{CC} = 3.3\text{V}$, $T_A = 25^\circ\text{C}$ and not 100% tested.



512K X 16 BIT LOW POWER CMOS SRAM

AC OPERATING CONDITIONS

Test Conditions (Test Load and Test Input/Output Reference)

Input Pulse Level : 0.4 to 2.4V

Input Rise and Fall Time : 5ns

Input and Output reference Voltage : 1.5V

Output Load (See right) : $CL^{(1)} = 100\text{pF} + 1 \text{ TTL}(70\text{nsec})$ $CL^{(1)} = 30\text{pF} + 1 \text{ TTL}(45\text{ns}/55\text{ns})$

1. Including scope and Jig capacitance

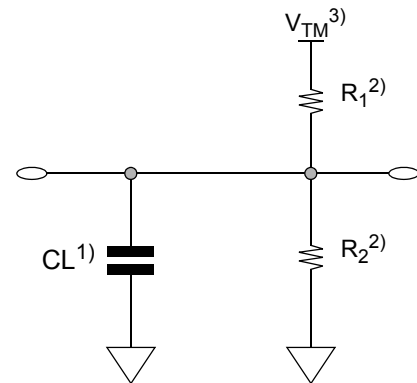
2. $R_1=3070\Omega$, $R_2=3150\Omega$ 3. $V_{TM}=2.8\text{V}$ 4. $CL = 5\text{pF} + 1 \text{ TTL}$ (measurement with t_{LZ} , t_{HZ} , t_{OLZ} , t_{OHZ} , t_{WHZ})READ CYCLE ($V_{CC}=2.7$ to 3.6V , $Gnd = 0\text{V}$, $T_A = -40^\circ\text{C}$ to $+85^\circ\text{C}$)

	Symbol	55ns		Unit
		Min	Max	
Read cycle time	t_{RC}	55	-	ns
Address access time	t_{AA}	-	55	ns
Chip select to output	t_{CO}	-	55	ns
Output enable to valid output	t_{OE}	-	35	ns
\overline{UB} , \overline{LB} access time	t_{BA}		45	ns
Chip select to low-Z output	t_{LZ}	5	-	ns
\overline{UB} , \overline{LB} enable to low-Z output	t_{BLZ}	5	-	ns
Output enable to low-Z output	t_{OLZ}	5	-	ns
Chip disable to high-Z output	t_{HZ}	0	20	ns
\overline{UB} , \overline{LB} disable to how-Z output	t_{BHZ}	0	20	ns
Output disable to high-Z output	t_{OHZ}	0	20	ns
Output hold from address change	t_{OH}	10	-	ns

WRITE CYCLE ($V_{CC}=2.7$ to 3.6V , $Gnd = 0\text{V}$, $T_A = -40^\circ\text{C}$ to $+85^\circ\text{C}$)

Parameter	Symbol	55ns		Unit
		Min	Max	
Write cycle time	t_{WC}	55	-	ns
Chip select to end of write	t_{CW}	45	-	ns
Address setup time	t_{AS}	0	-	ns
Address valid to end of write	t_{AW}	45	-	ns
\overline{UB} , \overline{LB} valid to end of write	t_{BW}	45	-	ns
Write pulse width	t_{WP}	45	-	ns
Write recovery time	t_{WR}	0	-	ns
Write to output high-Z	t_{WHZ}	0	20	ns
Data to write time overlap	t_{DW}	25		ns
Data hold from write time	t_{DH}	0	-	ns
End write to output low-Z	t_{OW}	5	-	ns



512K X 16 BIT LOW POWER CMOS SRAM

TIMING DIAGRAMS

TIMING WAVEFORM OF READ CYCLE(1) (Address Controlled, $\overline{CS}=\overline{OE}=V_{IL}$, $\overline{WE}=V_{IH}$, \overline{UB} or/and $\overline{LB}=V_{IL}$)

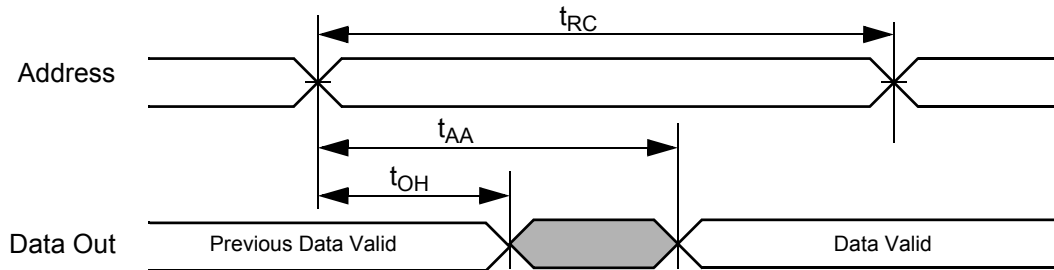

TIMING WAVEFORM OF READ CYCLE(2) ($\overline{WE} = V_{IH}$)

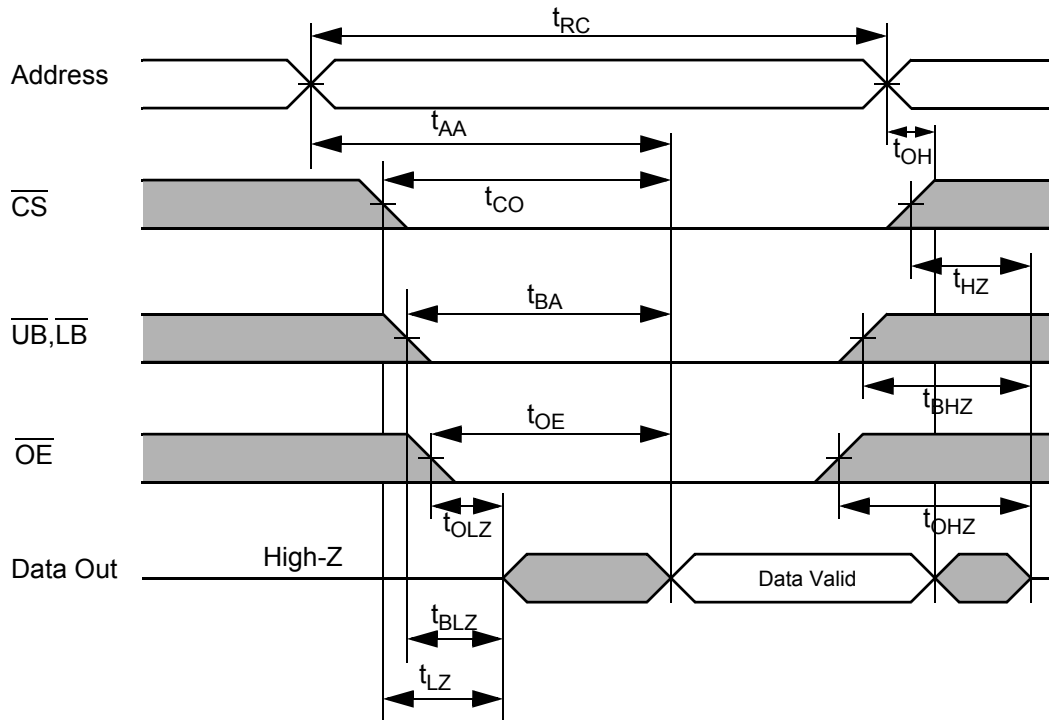

NOTES (READ CYCLE)

1. t_{HZ} and t_{OHZ} are defined as the outputs achieve the open circuit conditions and are not referenced to output voltage levels.
2. At any given temperature and voltage condition, $t_{HZ}(\text{Max.})$ is less than $t_{LZ}(\text{Min.})$ both for a given device and from device to device interconnection.



512K X 16 BIT LOW POWER CMOS SRAM

TIMING WAVEFORM OF WRITE CYCLE(1) (\overline{WE} Controlled)

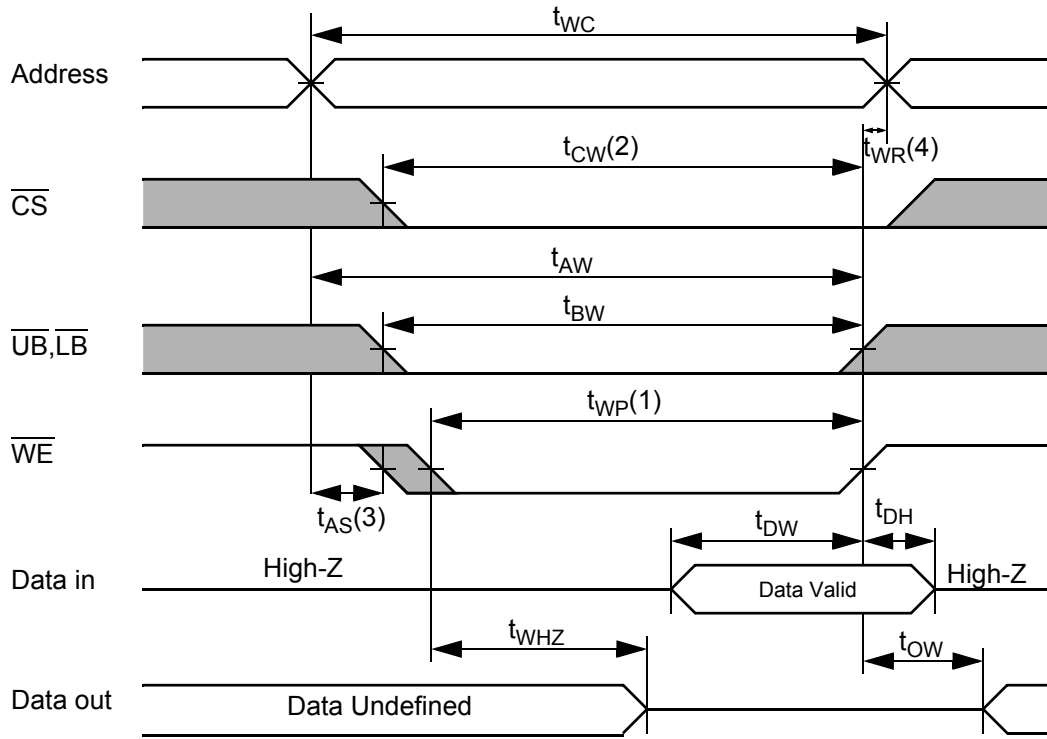

TIMING WAVEFORM OF WRITE CYCLE(2) (\overline{CS} Controlled)

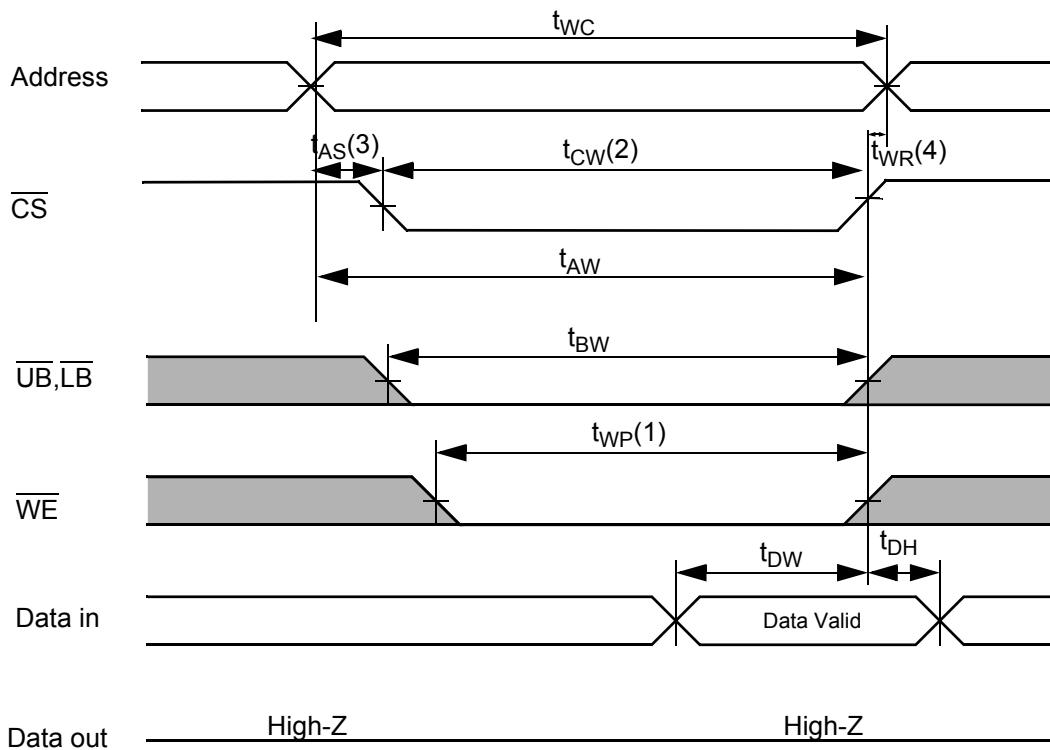

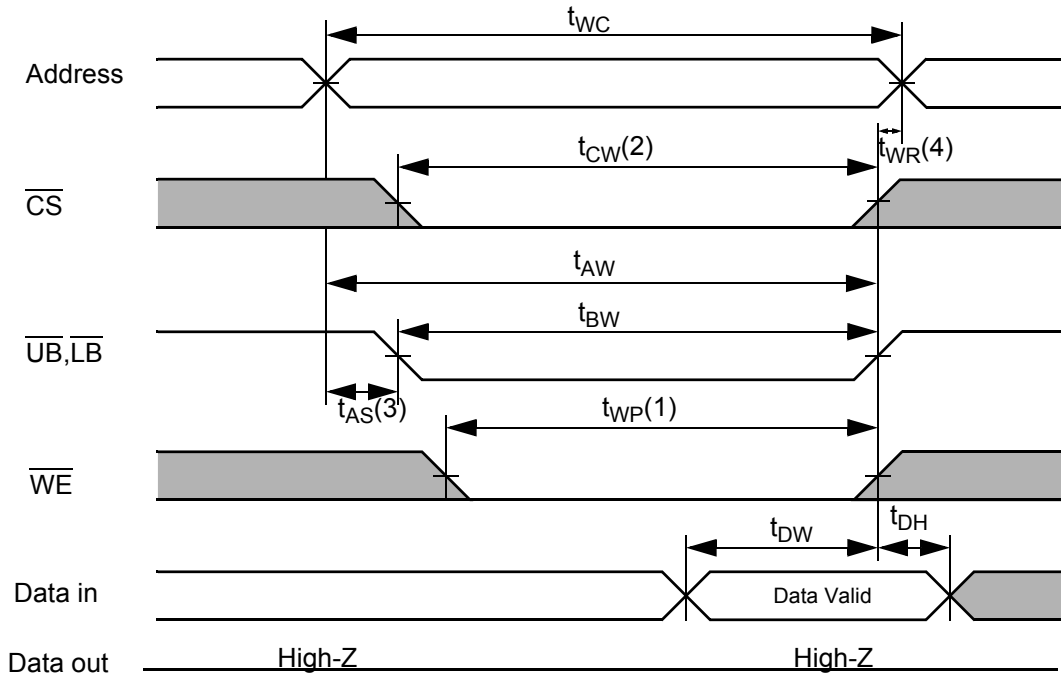

512K X 16 BIT LOW POWER CMOS SRAM

TIMING WAVEFORM OF WRITE CYCLE(3) (\overline{UB} , \overline{LB} Controlled)**NOTES (WRITE CYCLE)**

1. A write occurs during the overlap(t_{WP}) of low \overline{CS} and low \overline{WE} . A write begins when \overline{CS} goes low and \overline{WE} goes low with asserting \overline{UB} or \overline{LB} for single byte operation or simultaneously asserting \overline{UB} and \overline{LB} for double byte operation. A write ends at the earliest transition when \overline{CS} goes high and \overline{WE} goes high. The t_{WP} is measured from the beginning of write to the end of write.
2. t_{CW} is measured from the \overline{CS} going low to end of write.
3. t_{AS} is measured from the address valid to the beginning of write.
4. t_{WR} is measured from the end of write to the address change. t_{WR} applied in case a write ends as \overline{CS} or \overline{WE} going high.



512K X 16 BIT LOW POWER CMOS SRAM

DATA RETENTION CHARACTERISTICS

	Symbol	Test Condition	Min	Typ	Max	Unit
V _{CC} for Data Retention	V _{DR}	I _{SB1} Test Condition (Chip Disabled) ¹⁾	1.5	-	3.6	V
Data Retention Current	I _{DR}	V _{CC} =1.5V, I _{SB1} Test Condition (Chip Disabled) ¹⁾	-	-	4	μA
Chip Deselect to Data Retention Time	t _{SDR}	See data retention wave form	0	-	-	ns
Operation Recovery Time	t _{RDR}		t _{RC}	-	-	

NOTES

1. See the I_{SB1} measurement condition of datasheet page 4.

DATA RETENTION WAVE FORM

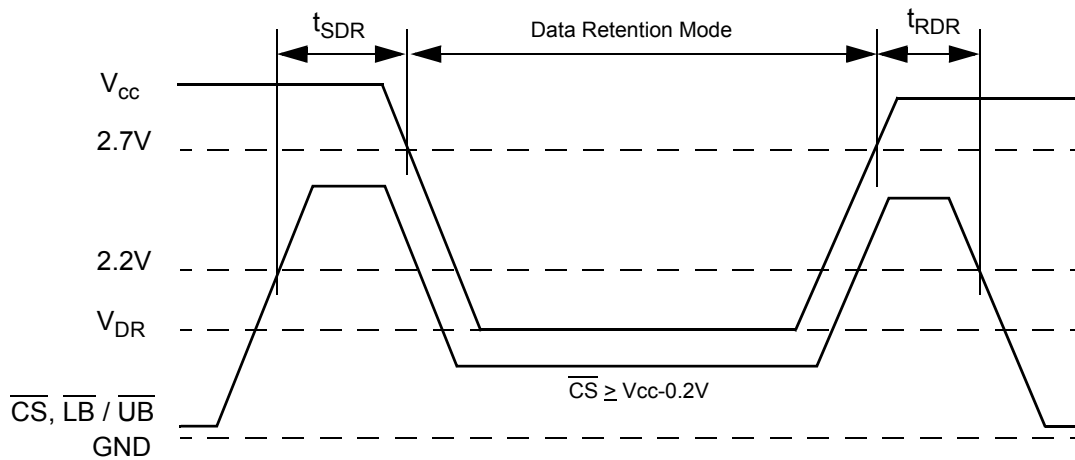



512K X 16 BIT LOW POWER CMOS SRAM

PACKAGE DIMENSION

44 - TSOP2 (0.8mm pin pitch)

Unit : millimeters / inches

44 PIN THIN SMALL OUTLINE PACKAGE TYPE II (400F)

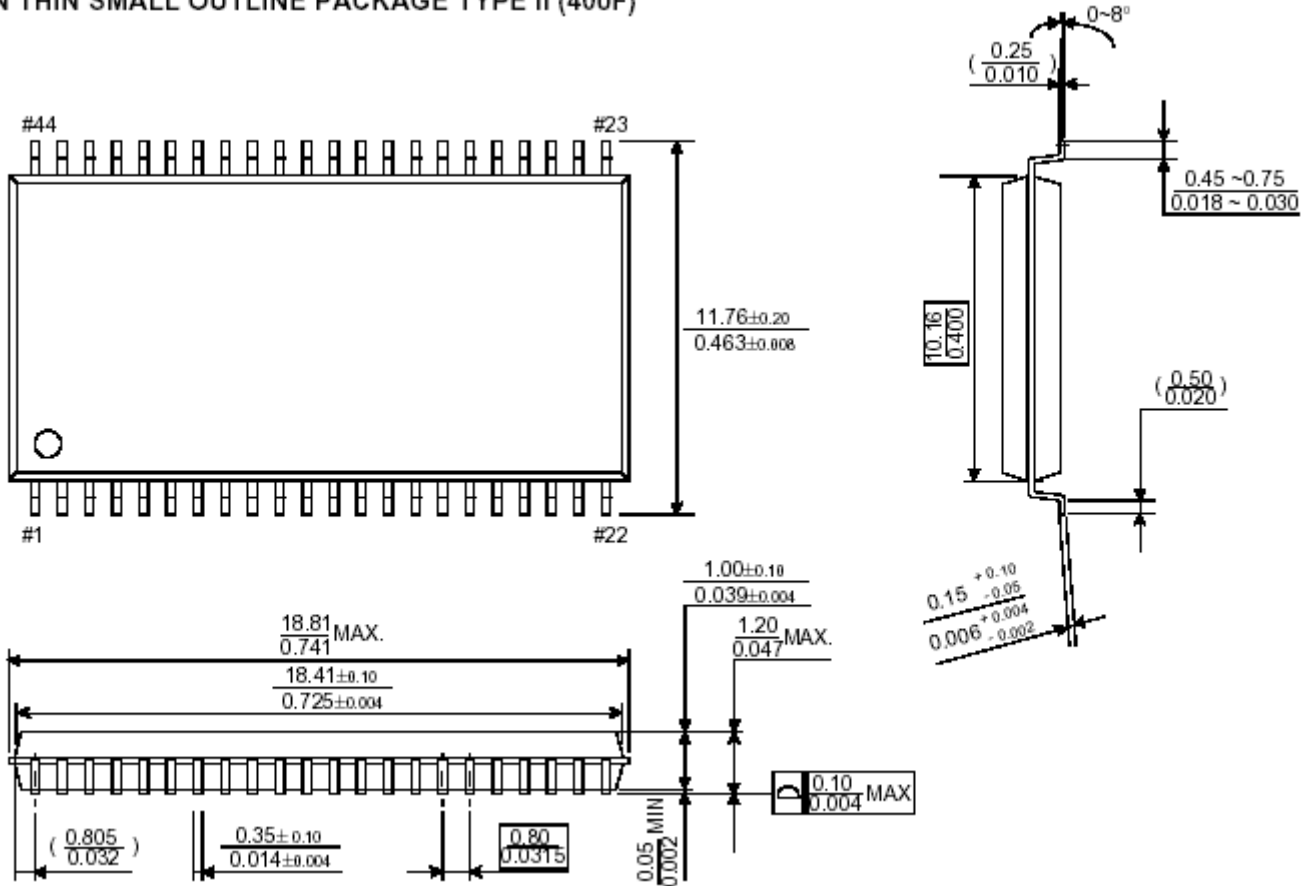



512K X 16 BIT LOW POWER CMOS SRAM

48 Ball Fine Pitch BGA (0.75mm ball pitch)

Unit: millimeters

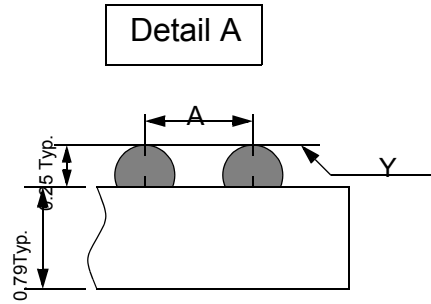
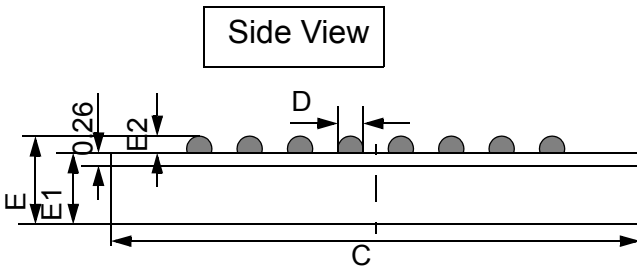
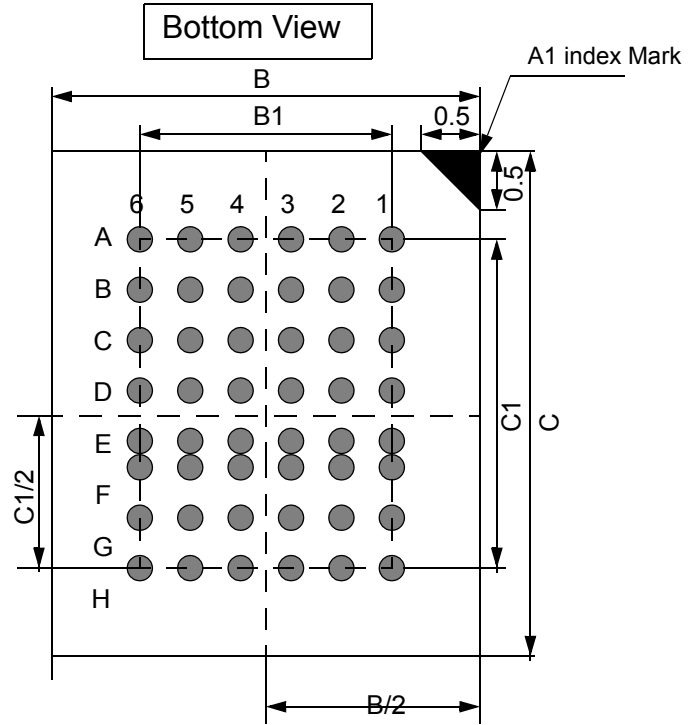
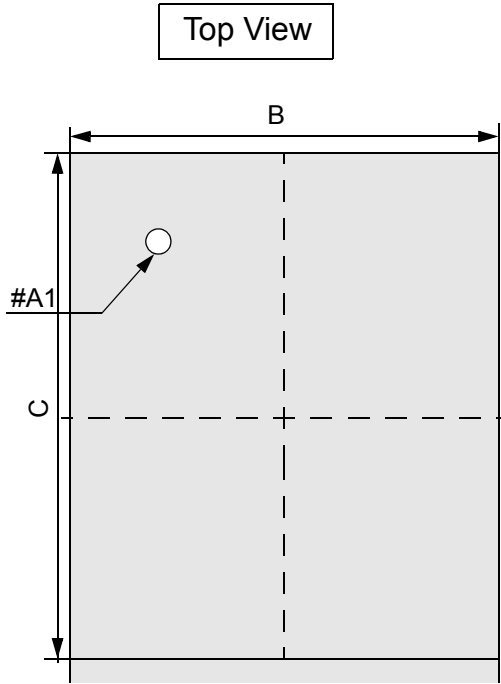

	Min	Typ	Max
A	-	0.75	-
B	7.95	8.00	8.05
B1	-	3.75	-
C	9.95	10.00	10.05
C1	-	5.25	-
D	0.30	0.35	0.40
E	-	-	1.00
E1	-	-	0.70
E2	0.20	0.25	0.30
Y	-	-	0.08

NOTES.

1. Bump counts : 48(8row x 6column)
2. Bump pitch : (x,y)=(0.75x0.75) (typ.)
3. All tolerance are +/-0.050 unless otherwise specified.
4. Typ : Typical
5. Y is coplanarity : 0.08(Max)



512K X 16 BIT LOW POWER CMOS SRAM

ORDERING INFORMATION

Alliance	Organization	VCC Range	Package	Operating Temp	Speed ns
AS6C8016A -55ZIN	512K x 16	2.7 - 3.6V	44pin TSOP II	Industrial ~ -40 C - 85 C	55
AS6C8016A -55BIN	512K x 16	2.7 - 3.6V	48ball FBGA	Industrial ~ -40 C - 85 C	55

PART NUMBERING SYSTEM

AS6C	8016	-55	X	X	N
Low power SRAM prefix	Device Number 80 = 8M 16 = x16	Access Time	Package Option Z - 44pin TSOP B = 48ball FBGA	Temperature Range I = Industrial (-40 to + 85 C)	N = Lead Free RoHS compliant part



Alliance Memory, Inc
551 Taylor Way,
San Carlos, CA 94070, USA
Phone: 650-610-6800
Fax: 650-620-9211



www.alliancememory.com

Copyright © Alliance Memory
All Rights Reserved

© Copyright 2007 Alliance Memory, Inc. All rights reserved. Our three-point logo, our name and Intelliwatt are trademarks or registered trademarks of Alliance. All other brand and product names may be the trademarks of their respective companies. Alliance reserves the right to make changes to this document and its products at any time without notice. Alliance assumes no responsibility for any errors that may appear in this document. The data contained herein represents Alliance's best data and/or estimates at the time of issuance. Alliance reserves the right to change or correct this data at anytime, without notice. If the product described herein is under development, significant changes to these specifications are possible. The information in this product data sheet is intended to be general descriptive information for potential customers and users, and is not intended to operate as, or provide, any guarantee or warranty to any user or customer. Alliance does not assume any responsibility or liability arising out of the application or use of any product described herein, and disclaims any express or implied warranties related to the sale and/or use of Alliance products including liability or warranties related to fitness for a particular purpose, merchantability, or infringement of any intellectual property rights, except as expressly agreed to in Alliance's Terms and Conditions of Sale (which are available from Alliance). All sales of Alliance products are made exclusively according to Alliance's Terms and Conditions of Sale. The purchase of products from Alliance does not convey a license under any patent rights, copyrights; mask works rights, trademarks, or any other intellectual property rights of Alliance or third parties. Alliance does not authorize its products for use as critical components in life-supporting systems where a malfunction or failure may reasonably be expected to result in significant injury to the user, and the inclusion of Alliance products in such life-supporting systems implies that the manufacturer assumes all risk of such use and agrees to indemnify Alliance against all claims arising from such use.

Looking for pricing, stock, or lifecycle information?

Click below to explore more details on WIN SOURCE:

-  [View AS6C8016A-55ZIN on WIN SOURCE](#)
-  [Alliance Memory, Inc. Information](#)

Optimize Your Supply Chain with WIN SOURCE Solutions

-  Global Sourcing Solution
-  Obsolete Management
-  Cost Control Management
-  Shortage Management
-  Alternative Solution
-  Excess Inventory Management