



THE DATASHEET OF
AL9910-5S-13



Description

The AL9910/A high voltage PWM LED driver-controller provides an efficient solution for offline high brightness LED lamps from rectified line voltages ranging from 85V_{AC} up to 277V_{AC}. The AL9910 drives external MOSFETs at switching frequencies up to 300kHz, with the switching frequency determined by a single resistor. The AL9910 topology creates a constant current through the LEDs providing constant light output. The output current is programmed by one external resistor and is ultimately determined by the external MOSFET chosen and therefore allows many low current LEDs to be driven as well as a few high current LEDs.

The LED brightness can be varied by both Linear and PWM dimming using the AL9910's LD and PWM_D pins respectively. The PWM_D input operates with duty ratio of 0-100% and frequency of up to several kHz.

The AL9910 can withstand input voltages up to 500V which makes it very resilient to transients at standard mains voltages. As well as standard SO-8 package the AL9910 is available in the thermally enhanced SO-8EP package.

Features

- >90% Efficiency
- Universal Rectified 85 to 277V_{AC} Input Range
- Input Voltage Up to 500V
- Internal Voltage Regulator Removes Start-Up Resistor
 - 7.5V MOSFET Drive – AL9910
 - 10V MOSFET Drive – AL9910A
- Tighter Current Sense Tolerance: 5% AL9910-5, AL9910A-5
- Drives LED Lamps with Both High and Low Current LEDs
- LED Brightness Control with Linear and PWM Dimming
- Internal Thermal Protection (OTP)
- Available in SO-8 and SO-8EP Packages
- **Totally Lead-Free & Fully RoHS Compliant (Notes 1 & 2)**
- **Halogen and Antimony Free. "Green" Device (Note 3)**

- Notes:
1. No purposely added lead. Fully EU Directive 2002/95/EC (RoHS) & 2011/65/EU (RoHS 2) compliant.
 2. See http://www.diodes.com/quality/lead_free.html for more information about Diodes Incorporated's definitions of Halogen- and Antimony-free, "Green" and Lead-free.
 3. Halogen- and Antimony-free "Green" products are defined as those which contain <900ppm bromine, <900ppm chlorine (<1500ppm total Br + Cl) and <1000ppm antimony compounds.

Pin Assignments

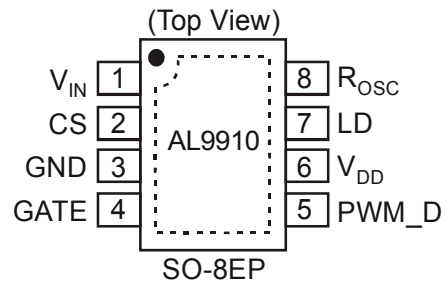
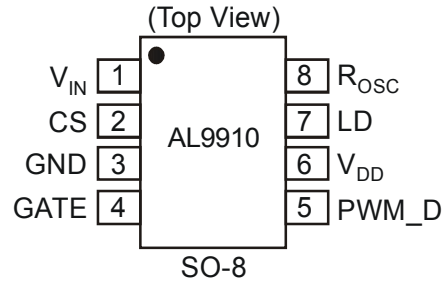

Applications

- LED Offline Lamps
- High Voltage DC-DC LED Driver
- Signage and Decorative LED Lighting
- Back Lighting of Flat Panel Displays
- General Purpose Constant Current Source

Typical Applications Circuit

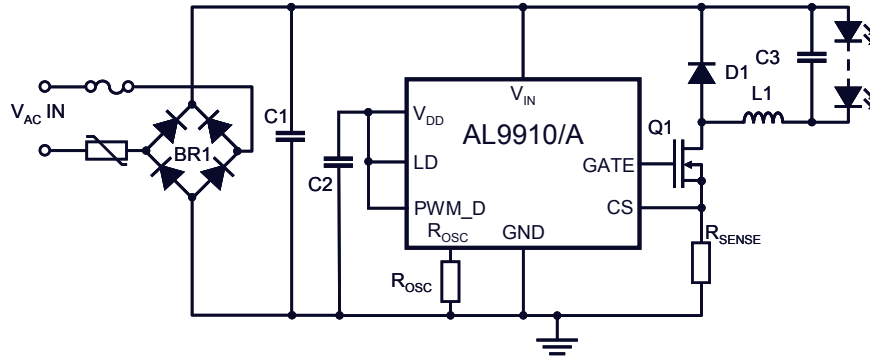

Pin Descriptions

Pin Name	Pin Number		Function
	SO-8	SO-8EP	
V _{IN}	1	1	Input Voltage
CS	2	2	Senses LED string and external MOSFET switch current
GND	3	3	Device Ground
Gate	4	4	Drives the gate of the external MOSFET switch.
PWM_D	5	5	Low Frequency PWM Dimming pin, also Enable input. Internal 200kΩ pull-down to GND.
V _{DD}	6	6	Internally regulated supply voltage. <ul style="list-style-type: none"> 7.5V nominal for AL9910 and AL9910-5 10V nominal for AL9910A. Can supply up to 1 mA for external circuitry. A sufficient storage capacitor is used to provide storage when the rectified AC input is near the zero crossing.
LD	7	7	Linear Dimming Input. Changes the current limit threshold at current sense comparator and changes the average LED current.
R _{OSC}	8	8	Oscillator Control. A resistor connected between this pin and ground sets the PWM frequency. The devices can be switched into constant off time (PFM) mode by connecting the external oscillator resistor between R _{osc} pin and the gate of the external MOSFET.
EP PAD	N/A	EP	Exposed Pad (bottom). Connect to GND directly underneath the package.

Functional Block Diagram

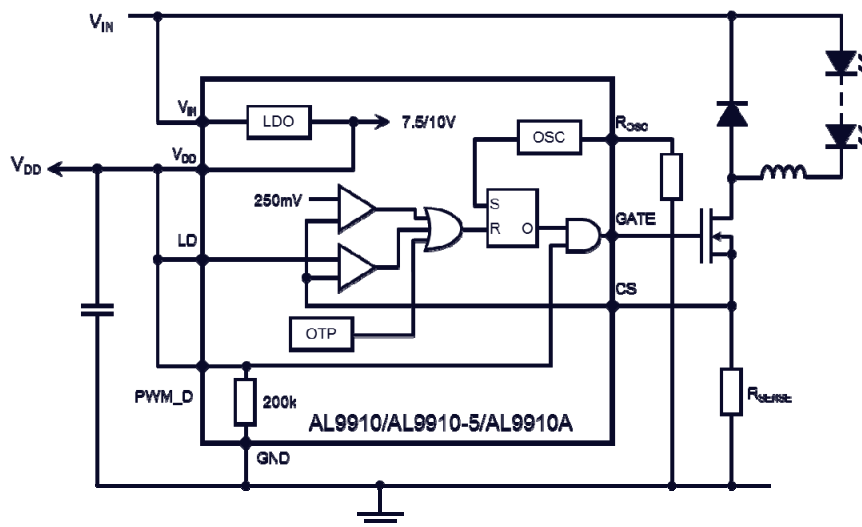

Absolute Maximum Ratings (Note 4) (@ $T_A = +25^\circ\text{C}$, unless otherwise specified.)

Symbol	Parameter	Ratings	Unit
$V_{IN(MAX)}$	Maximum Input Voltage, V_{IN} , to GND	-0.5 to +520	V
V_{CS}	Maximum CS Input Pin Voltage Relative to GND	-0.3 to +0.45	V
V_{LD}	Maximum LD Input Pin Voltage Relative to GND	-0.3 to ($V_{DD} + 0.3$)	V
V_{PWM_D}	Maximum PWM_D Input Pin Voltage Relative to GND	-0.3 to ($V_{DD} + 0.3$)	V
V_{GATE}	Maximum GATE Pin Voltage Relative to GND	-0.3 to ($V_{DD} + 0.3$)	V
$V_{DD(MAX)}$	Maximum V_{DD} Pin Voltage Relative to GND	12	V
	Continuous Power Dissipation ($T_A = +25^\circ\text{C}$)		
	SO-8 (derate 6.3mW/°C above +25°C)	630	mW
	SO-8EP (derate at 22mW/°C above 25°C)	2200	mW
T_J	Junction Temperature Range	+150	°C
T_{ST}	Storage Temperature Range	-65 to +150	°C
ESD HBM	Human Body Model ESD Protection (Note 5)	1500	V
ESD MM	Machine Model ESD Protection (Note 5)	300	V

- Notes:
- Stresses above those listed under Absolute Maximum Ratings may cause permanent damage to the device. This is a stress rating only; functional operation of the device at these or any other conditions above those listed in the operational sections of this specification is not implied. Exposure to absolute maximum rating conditions for extended periods may affect device reliability.
All voltages are with respect to Ground. Currents are positive into, negative out of the specified terminal.
 - Semiconductor devices are ESD sensitive and may be damaged by exposure to ESD events. Suitable ESD precautions should be taken when handling and transporting these devices

Recommended Operating Conditions (@ $T_A = +25^\circ\text{C}$, unless otherwise specified.)

Symbol	Parameter	Min	Max	Unit	
V_{INDC}	Input DC Supply Voltage Range	AL9910 AL9910-5	15.0	500	V
		AL9910A AL9910A-5	20.0	500	
T_A	Ambient Temperature Range (Note 6)	AL9910_S	-40	+85	°C
		AL9910_SP	-40	+105	
V_{DD}	Maximum Recommended Voltage Applied to V_{DD} Pin (Note 7)	AL9910 AL9910-5		10	V
		AL9910A AL9910A-5		12	
$V_{EN(LO)}$	Pin PWM_D Input Low Voltage	0	1	V	
$V_{EN(HI)}$	Pin PWM_D Input High Voltage	2.4	V_{DD}		

- Notes:
- Maximum ambient temperature range is limited by allowable power dissipation. The Exposed pad SO-8EP with its lower thermal impedance allows the variants using this package to extend the allowable maximum ambient temperature range.
 - When using the AL9910 in isolated LED lamps an auxiliary winding might be used.

Electrical Characteristics (@T_A = +25°C, unless otherwise specified.)

Symbol	Parameter	Conditions	Min	Typ	Max	Unit	
I _{NSD}	Shut-Down Mode Supply Current	Pin PWM_D to GND, V _{IN} = V _{IN(MIN)} (Note 6)	AL9910	0.50	1	mA	
			AL9910-5				
			AL9910A	0.65	1.2		
V _{DD}	Internally Regulated Voltage	V _{IN} = V _{IN(MIN)} ~500V, (Note 8) I _{DD(ext)} = 0, Gate pin open	AL9910	7.0	7.5	8.0	V
			AL9910-5				
			AL9910A	9	10	11	
I _{DD(ext)}	V _{DD} Current Available for External Circuitry	V _{IN} = V _{IN(MIN)} to 100V (Notes 8 & 9)			1.0	mA	
UVLO	V _{DD} Under Voltage Lockout Threshold	V _{DD} rising	AL9910	6.4	6.7	7	V
			AL9910-5				
			AL9910A	8	9	10	
ΔUVLO	V _{DD} Under Voltage Lockout Hysteresis	V _{DD} falling	AL9910		500		mV
			AL9910-5				
			AL9910A		750		
R _{PWM_D}	PWM_D Pull-Down Resistance	V _{PWM_D} = 5V	150	200	250	kΩ	
V _{CS(HI)}	Current Sense Threshold Voltage	Full ambient temperature range (Note 10)	AL9910	225	250	275	mV
			AL9910A	230	255	280	
			AL9910A-5	242	255	267	
			AL9910-5	237.5	250	262.5	
V _{GATE(HI)}	GATE High Output Voltage	I _{OUT} = 10mA	V _{DD} - 0.3		V _{DD}	V	
V _{GATE(LO)}	GATE Low Output Voltage	I _{OUT} = -10mA	0		0.3	V	
f _{OSC}	Oscillator Frequency	R _{OSC} = 1MΩ	20	25	30	kHz	
		R _{OSC} = 226kΩ	80	100	120		
D _{MAXhf}	Maximum Oscillator PWM Duty Cycle	f _{PWMhf} = 25kHz, at GATE, CS to GND.			100	%	
V _{LD}	Linear Dimming Pin Voltage Range	Full ambient temperature range (Note 10), V _{IN} = 20V	0	-	250	mV	
t _{BLANK}	Current Sense Blanking Interval	V _{CS} = 0.45V, V _{LD} = V _{DD}	160	250	440	ns	
t _{DELAY}	Delay From CS Trip to GATE Io	V _{IN} = 20V, V _{LD} = 0.15, V _{CS} = 0 to 0.22V after T _{BLANK}			300	ns	
t _{RISE}	GATE Output Rise Time	C _{GATE} = 500pF		30	50	ns	
t _{FALL}	GATE Output Fall Time	C _{GATE} = 500pF		30	50	ns	
T _{SD}	Thermal Shut Down			150		°C	
T _{SDH}	Thermal Shut Down Hysteresis			50			
θ _{JA}	Thermal Resistance Junction-to-Ambient	SO-8 (Note 11)		110		°C/W	
		SO-8EP (Note 12)		66			
θ _{JC}	Thermal Resistance Junction-to-Case	SO-8 (Note 11)		22		°C/W	
		SO-8EP (Note 12)		9			

- Notes:
- V_{IN(MIN)} for the AL9910 is 15V and for the AL9910A is 20V.
 - Also limited by package power dissipation limit, whichever is lower.
 - Full ambient temperature range for AL9910-5S, AL9910AS and AL9910S is -40 to +85°C; for AL9910-5SP, AL9910ASP and AL9910SP is -40°C to +105°C.
 - Device mounted on FR-4 PCB (25mm x 25mm 1oz copper, minimum recommended pad layout on top. For better thermal performance, larger copper pad for heat-sink is needed.
 - Device mounted on FR-4 PCB (51mm x 51mm 2oz copper, minimum recommended pad layout on top layer and thermal vias to bottom layer ground plane. For better thermal performance, larger copper pad for heat-sink is needed.

Typical Characteristics

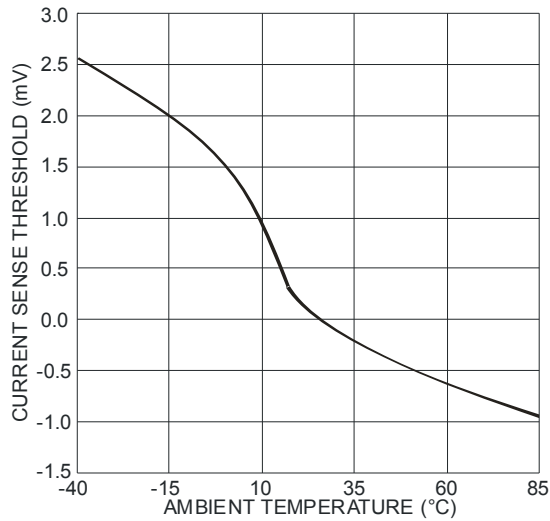

Change in Current Sense Threshold vs. Ambient Temperature

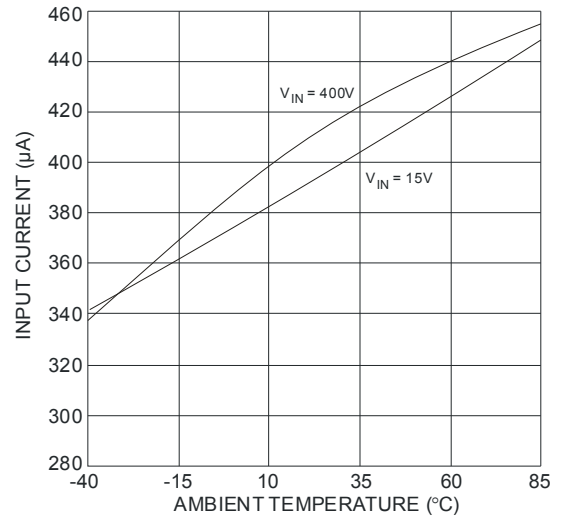

Input Current vs. Ambient Temperature

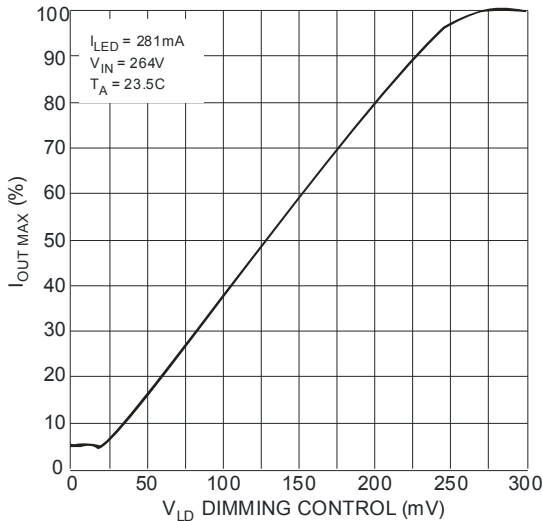

I_{OUT MAX} vs. V_{LD} Dimming Control

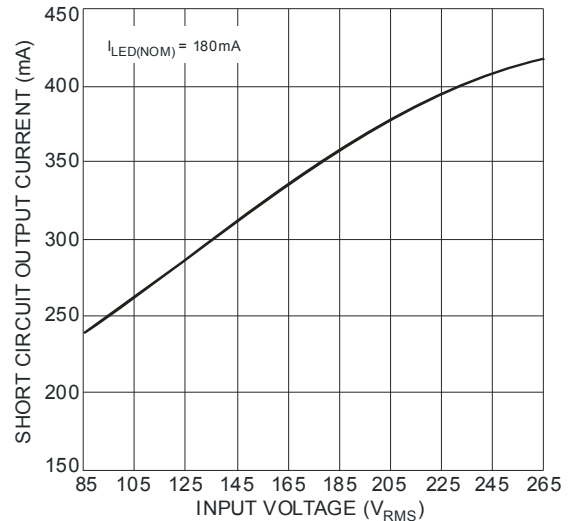

180mA LED Driver Short Circuit Output Current vs. Input Voltage

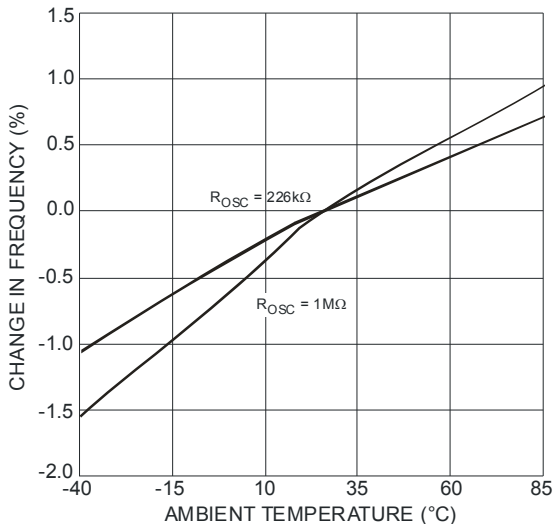

Change in Oscillation Frequency vs. Ambient Temperature

Typical Characteristics (cont.) measured using AL9910EV4

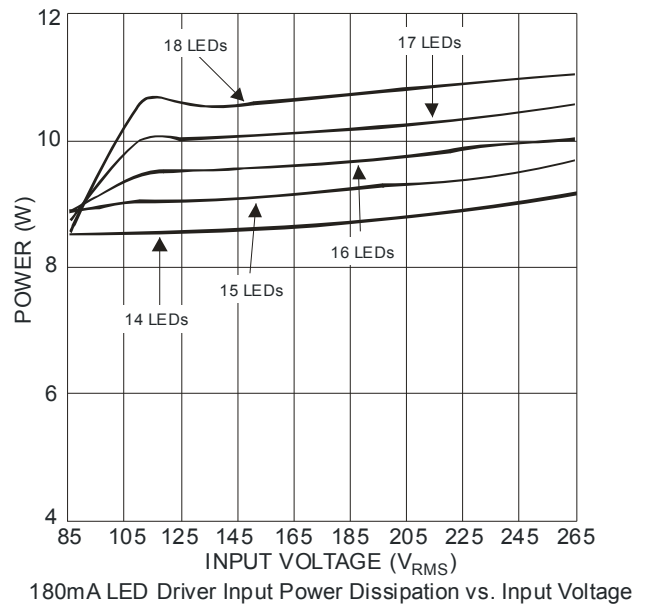
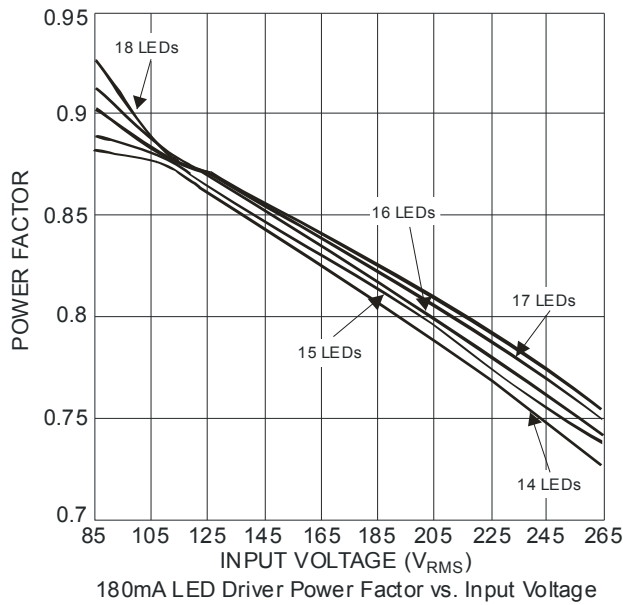
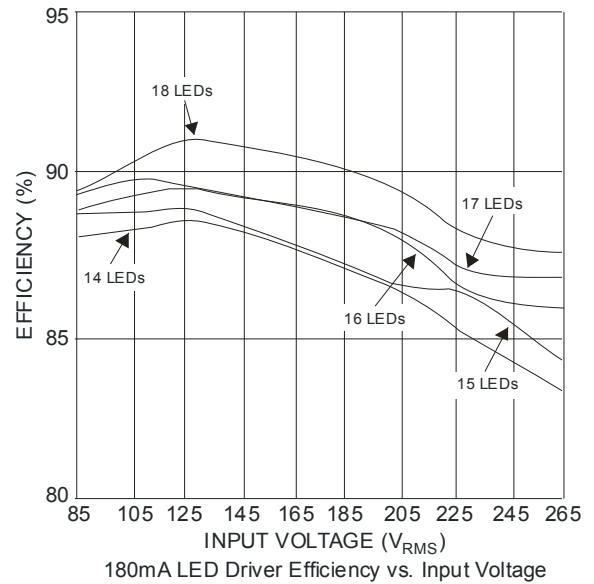
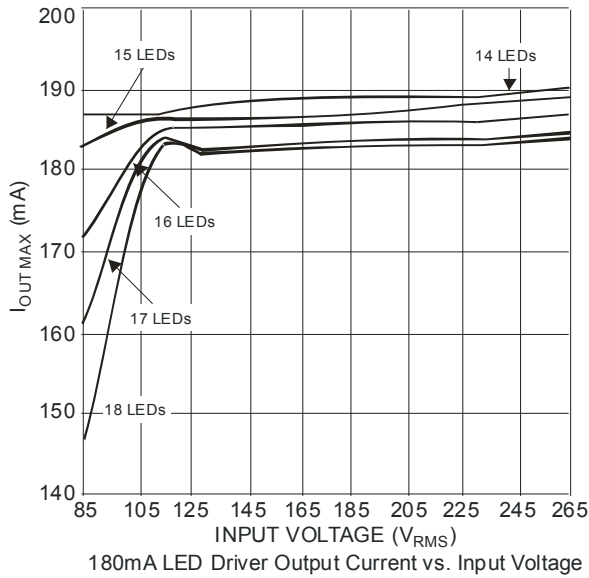

Application Information

The AL9910 is very versatile and is capable of operating in isolated or non-isolated topologies. It can also be made to operate in continuous as well as discontinuous conduction mode.

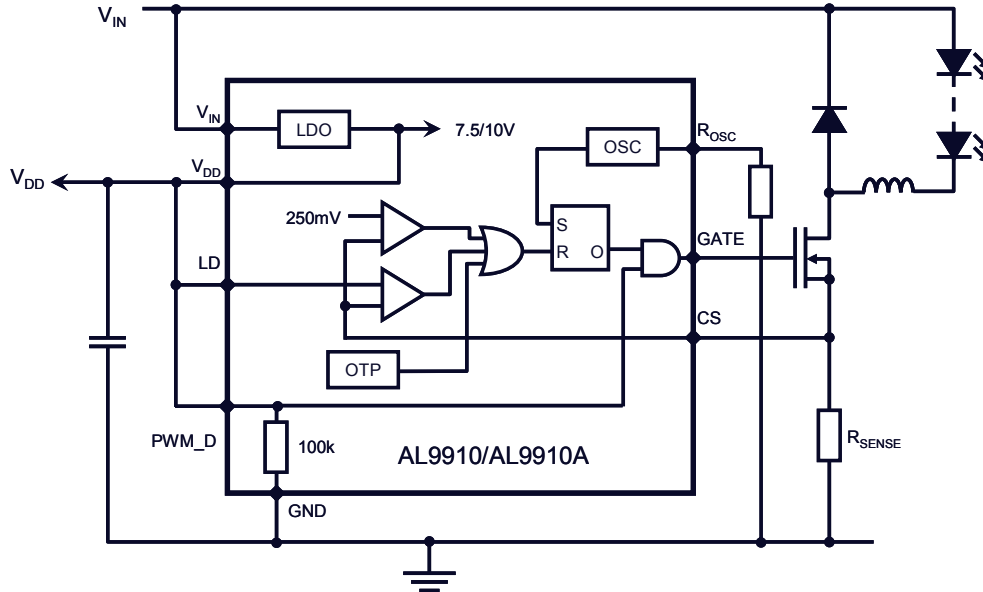

Figure 1 Functional Block Diagram

The AL9910 contains a high voltage LDO (see Figure 1) the output of the LDO provides a power rail to the internal circuitry including the gate driver. A UVLO on the output of the LDO prevents incorrect operation at low input voltage to the V_{IN} pin.

In a non-isolated Buck LED driver when the gate pin goes high the external power MOSFET Q1 is turned on causing current to flow through the LEDs, inductor (L1) and current sense resistor (R_{SENSE}). When the voltage across R_{SENSE} exceeds the current sense pin threshold the external MOSFET Q1 is turned off. The stored energy in the inductor causes the current to continue to flow through the LEDs via diode D1.

The AL9910's LDO provides all power to the rest of the IC including Gate drive this removes the need for large high power start-up resistors. This means that operate correctly it requires around 0.5mA from the high voltage power rail. The LDO can also be used to supply up to 1mA to external circuits.

The AL9910 operates and regulates by limiting the peak current of the external MOSFET; the peak current sense threshold is nominally set at 250mV.

The same basic operation is true for isolated topologies, however in these the energy stored in the transformer delivers energy to LEDs during the off-cycle of the external MOSFET.

Design Parameters

Setting the LED Current

In the non-isolated buck converter topology, figure 1, the average LED current is not the peak current divided by 2 - however, there is a certain error due to the difference between the peak and the average current in the inductor. The following equation accounts for this error:

$$R_{SENSE} = \frac{250mV}{(I_{LED} + (0.5 * I_{RIPPLE}))}$$

Applications Information (cont.)

Setting Operating Frequency

The AL9910 is capable of operating over a 25 and 300 kHz switching frequency range. The switching frequency is programmed by connecting an external resistor between R_{OSC} pin and ground. The corresponding oscillator period is:

$$t_{OSC} = \frac{R_{OSC} + 22}{25} \mu s \quad \text{with } R_{OSC} \text{ in } k\Omega$$

The switching frequency is the reciprocal of the oscillator period. Typical values for R_{OSC} vary from 75kΩ to 1MΩ

When driving smaller numbers of LEDs, care should be taken to ensure that t_{ON} > t_{BLANK}. The simplest way to do this is to reduce/limit the switching frequency by increasing the R_{OSC} value. Reducing the switching frequency will also improve the efficiency.

When operating in buck mode the designer must keep in mind that the input voltage must be maintained higher than 2 times the forward voltage drop across the LEDs. This limitation is related to the output current instability that may develop when the AL9910 operates at a duty cycle greater than 0.5. This instability reveals itself as an oscillation of the output current at a sub-harmonic (SBO) of the switching frequency.

The best solution is to adopt the so-called constant off-time operation as shown in Figure 2. The resistor (R_{OSC}) is, connected by default, to set operating frequency. To force the AL9910 to enter constant OFF time mode R_{OSC} is connected to the gate of the external MOSFET. This will decrease the duty cycle from 50% by increasing the total period, t_{OFF} + t_{ON}.

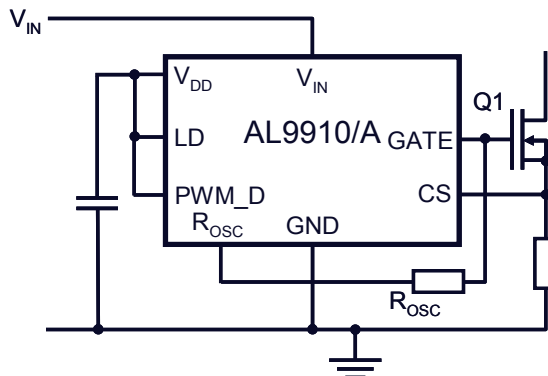

Figure 2. Constant Off-Time Configuration

The oscillator period equation above now defines the AL9910 off time, t_{OFF}.

When using this mode the nominal switching frequency is chosen and from the nominal input and output voltages the off-time can be calculated:

$$t_{OFF} = \left(1 - \frac{V_{OUT(nom)}}{V_{IN(nom)}}\right) * \frac{1}{f_{OSC}}$$

From this the timing resistor, R_{OSC}, can be calculated: $R_{OSC} = (t_{OFF}(\mu s) * 25) - 22(k\Omega)$

Inductor Selection

The non-isolated buck circuit, Figure 1, is usually selected and it has two operation modes: continuous and discontinuous conduction modes. A buck power stage can be designed to operate in continuous mode for load current above a certain level usually 15% to 30% of full load. Usually, the input voltage range, the output voltage and load current are defined by the power stage specification. This leaves the inductor value as the only design parameter to maintain continuous conduction mode. The minimum value of inductor to maintain continuous conduction mode can be determined by the following example.

The required inductor value is determined from the desired peak-to-peak LED ripple current in the inductor; typically around 30% of the nominal LED current.

$$L = \frac{(V_{IN} - V_{LEDS}) \times D}{(0.3 \times I_{LED}) \times f_{OSC}} \quad \text{Where D is duty cycle}$$

The next step is determining the total voltage drop across the LED string. For example, when the string consists of 10 High-Brightness LEDs and each diode has a forward voltage drop of 3.0V at its nominal current; the total LED voltage V_{LEDS} is 30V.

Applications Information (cont.)

Dimming

The LED brightness can be dimmed either linearly (using the LD pin) or via pulse width modulation (using the PWM-D pin); or a combination of both - depending on the application. Pulling the PWM_D pin to ground will turn off the AL9910. When disabled, the AL9910's quiescent current is typically 0.5mA (0.65 for AL9910A). Reducing the LD voltage will reduce the LED current but it will not entirely turn off the external power transistor and hence the LED current – this is due to the finite blanking period. Only the PWM_D pin will turn off the power transistor.

Linear dimming is accomplished by applying a 45mV to 250mV analog signal to the LD pin. This overrides the default 250mV threshold level of the CS pin and reduces the output current. If an input voltage greater than 250mV is applied to the LD then the output current will not change.

The LD pin also provides a simple cost effective solution to soft start; by connecting a capacitor to the LD pin down to ground at initial power up the LD pin will be held low causing the sense threshold to be low. As the capacitor charges up the current sense threshold will increase thereby causing the average LED current to increase.

PWM dimming is achieved by applying an external PWM signal to the PWM_D pin. The LED current is proportional to the PWM duty cycle and the light output can be adjusted between zero and 100%. The PWM signal enables and disables the AL9910 - modulating the LED current. The ultimate accuracy of the PWM dimming method is limited only by the minimum gate pulse width, which is a fraction of a percentage of the low frequency duty cycle. PWM dimming of the LED light can be achieved by turning on and off the converter with low frequency 50Hz to 1000Hz TTL logic level signal.

With both modes of dimming it is not possible to achieve average brightness levels higher than the one set by the current sense threshold level of the AL9910. If a greater LED current is required then a smaller sense resistor should be used

Output Open Circuit Protection

The non-isolated buck LED driver topology provides inherent protection against an open circuit condition in the LED string due to the LEDs being connected in series with the inductor. Should the LED string become open circuit then no switching occurs and the circuit can be permanently left in this state with damage to the rest of the circuit.

AC/DC Off-Line LED Driver

The AL9910 is a cost-effective off-line buck LED driver-controller specifically designed for driving LED strings. It is suitable for being used with either rectified AC line or any DC voltage between 15V to 500V. See Figure 3 for typical circuit.

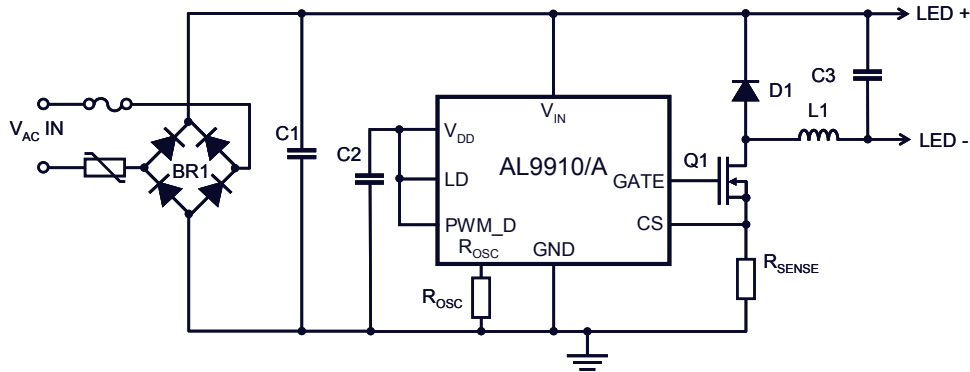

Figure 3. Typical Application Circuit (without PFC)

Buck Design Equations:

$$D = \frac{V_{LEDs}}{V_{IN}}$$

$$t_{ON} = \frac{D}{f_{osc}}$$

$$L \geq \frac{(V_{IN} - V_{LEDs}) \times t_{ON}}{0.3 \times I_{LED}}$$

$$R_{SENSE} = \frac{0.25}{I_{LED} + (0.5 \times (I_{LED} \times 0.3))} \text{ where } I_{LED} \times 0.3 = I_{RIPPLE}$$

Applications Information (cont.)

Design Example

For an AC line voltage of 120V the nominal rectified input voltage $V_{IN} = 120V \times 1.41 = 169V$. From this and the LED chain voltage the duty cycle can be determined:

$$D = V_{LEDs} / V_{IN} = 30/169 = 0.177$$

From the switching frequency, for example $f_{OSC} = 50kHz$, the required on-time of the external MOSFET can be calculated:

$$t_{ON} = D/f_{OSC} = 3.5 \mu s$$

The value of the inductor for an LED current of 350mA is determined as follows:

$$L = (V_{IN} - V_{LEDs}) * t_{ON} / (0.3 * I_{LED}) = 4.6mH$$

Input Bulk Capacitor

For Offline lamps an input bulk capacitor is required to ensure that the rectified AC voltage is held above twice the LED string voltage throughout the AC line cycle. The value can be calculated from:

$$C_{IN} \geq \frac{P_{IN} \times (1 - D_{CH})}{\sqrt{2} \times V_{LINE_MIN} \times 2f_L \times \Delta V_{DC_MAX}}$$

Where

D_{ch} : Capacity charge work period, generally about 0.2 to 0.25

f_L : Input frequency for full range (85 to 265V_{RMS})

ΔV_{DC_MAX} Should be set 10 to 15% of $\sqrt{2}V_{LINE_MIN}$

If the capacitor has a 15% voltage ripple then a simplified formula for the minimum value of the bulk input capacitor approximates to:

$$C_{MIN} = \frac{I_{LED} \times V_{LEDs} \times 0.06}{V_{IN}^2}$$

Power Factor Correction

If power factor improvement is required then for the input power less than 25W, a simple passive power factor correction circuit can be added to the AL9910 typical application circuit. Figure 4 shows that passive PFC circuitry (3 current steering diodes and 2 identical capacitors) does not significantly affect the rest of the circuit. Simple passive PFC improves the line current harmonic distortion and achieves a power factor greater than 0.85.

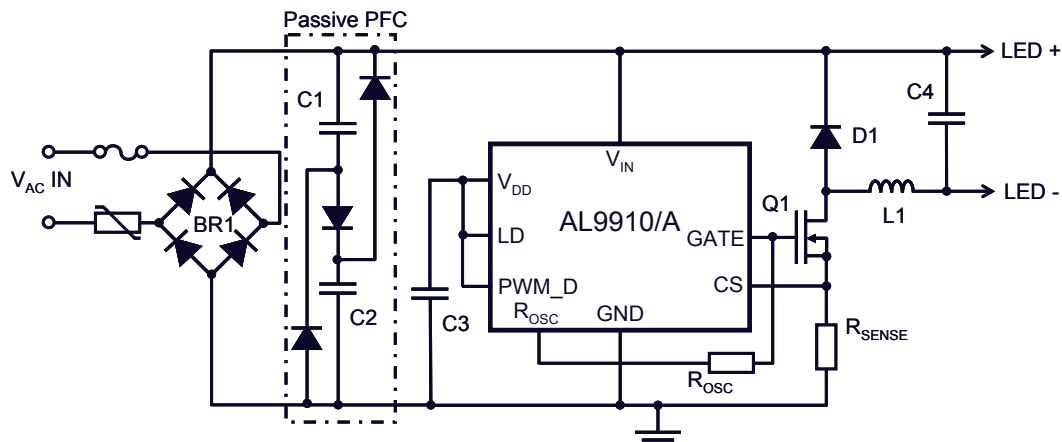

Figure 4. Typical Application Circuit with Passive PFC

Each of these identical capacitors should be rated for half of the input voltage and have twice as much capacitance as the calculated C_{MIN} of the buck converter circuit without passive PFC (see above section on bulk capacitor calculation).

For further design information please see AN75 from the Diodes website.

Applications Information (cont.)

DC-DC Buck LED Driver

The design procedure for an ac input buck LED driver outlined in the previous chapters equally applies DC input LED drivers. When driving long LED chains care should be taken not to induce SBO – maximum LED chain voltage should be less half of V_{IN} . So either maximum duty cycle should be kept below 50% or use of constant off-time removes this issue.

DC-DC Boost LED Driver

Due to the topology of the AL9910 LED driver-controller it is capable of being used in boost configurations – at reduced accuracy. The accuracy can be improved by measuring the LED current with an op amp and use the op amp’s output to drive the LD pin.

A Boost LED driver is used when the forward voltage drop of the LED string is higher than the input supply voltage. For example, the Boost topology can be appropriate when input voltage is supplied by a 48V power supply and the LED string consists of twenty HB LEDs, as the case may be for a street light.

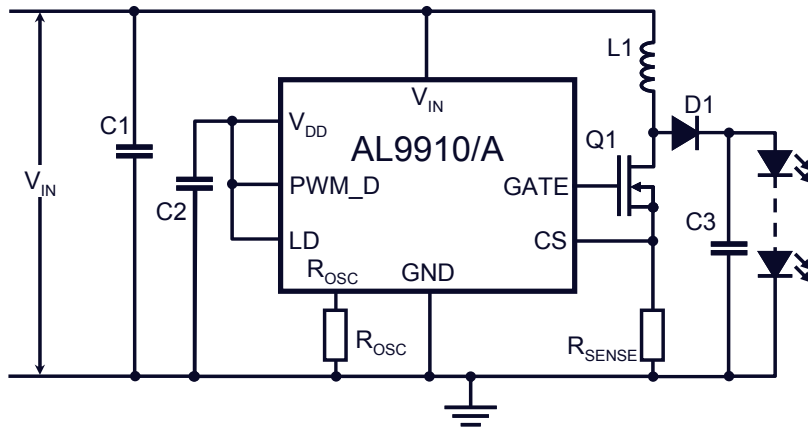

Figure 5. Boost LED Driver

In a Boost converter, when the external MOSFET is ON the energy is stored in the inductor which is then delivered to the output when the external MOSFET switches OFF. If the energy stored in the inductor is not fully depleted by the next switching cycle (continuous conduction mode) the DC conversion between input and output voltage is given by:

$$V_{OUT} = \frac{V_{IN}}{1-D} \rightarrow D = \frac{V_{OUT} - V_{IN}}{V_{OUT}}$$

From the switching frequency, f_{OSC} , the on-time of the MOSFET can be calculated:

$$t_{ON} = \frac{D}{f_{OSC}}$$

From this the required inductor value can be determined by:

$$L = \frac{V_{IN} * t_{ON}}{0.3 * I_{LED}}$$

The Boost topology LED driver requires an output capacitor to deliver current to the LED string during the time that the external MOSFET is on.

In boost LED driver topologies if the LEDs should become open circuit damage may occur to the power switch and so some form of detection should be present to provide Over-voltage detection/protection.

Ordering Information

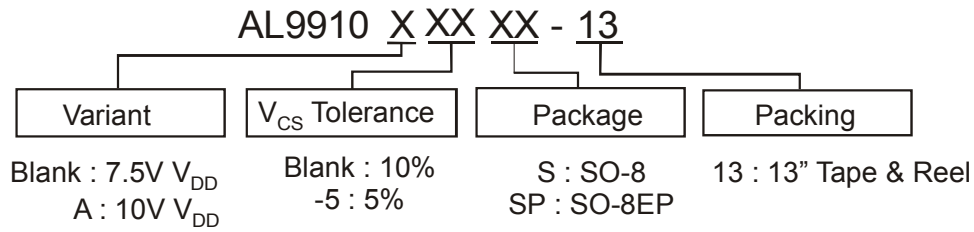

Part Number	V _{CS} Tolerance	Package Code	Packaging	13" Tape and Reel	
				Quantity	Part Number Suffix
AL9910-5S-13	±5%	S	SO-8	2500/Tape & Reel	-13
AL9910-5SP-13	±5%	SP	SO-8EP	2500/Tape & Reel	-13
AL9910A-5S-13	±5%	S	SO-8	2500/Tape & Reel	-13
AL9910A-5SP-13	±5%	SP	SO-8EP	2500/Tape & Reel	-13
AL9910AS-13	±10%	S	SO-8	2500/Tape & Reel	-13
AL9910ASP-13	±10%	SP	SO-8EP	2500/Tape & Reel	-13
AL9910S-13	±10%	S	SO-8	2500/Tape & Reel	-13
AL9910SP-13	±10%	SP	SO-8EP	2500/Tape & Reel	-13

Marking Information

(1) SO-8

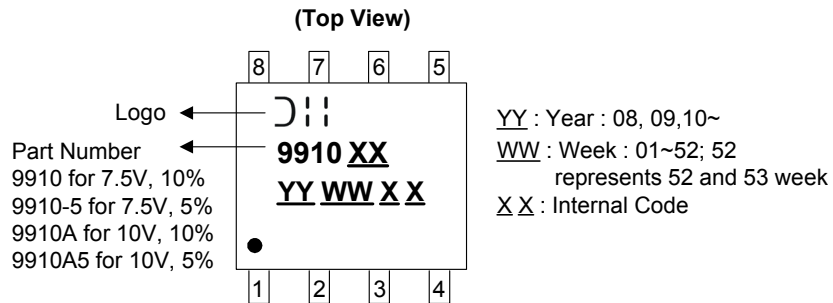

(2) SO8-EP

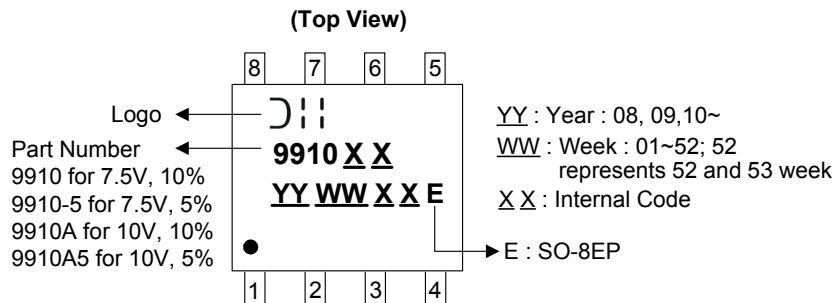

Package Outline Dimensions (All dimensions in mm.)

Please see AP02002 at <http://www.diodes.com/datasheets/ap02002.pdf> for latest version.

(1) SO-8

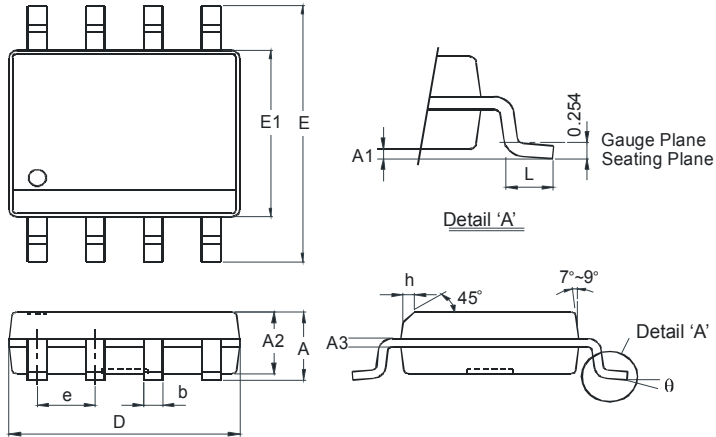

SO-8		
Dim	Min	Max
A	-	1.75
A1	0.10	0.20
A2	1.30	1.50
A3	0.15	0.25
b	0.3	0.5
D	4.85	4.95
E	5.90	6.10
E1	3.85	3.95
e	1.27 Typ	
h	-	0.35
L	0.62	0.82
θ	0°	8°
All Dimensions in mm		

(2) SO-8EP

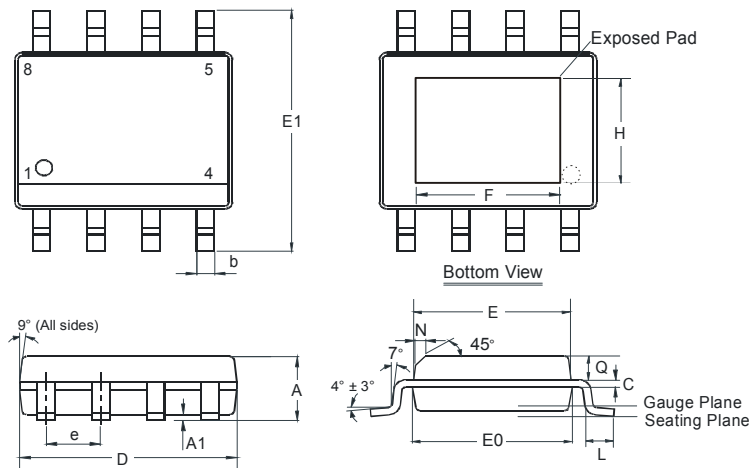

SO-8EP (SOP-8L-EP)			
Dim	Min	Max	Typ
A	1.40	1.50	1.45
A1	0.00	0.13	-
b	0.30	0.50	0.40
C	0.15	0.25	0.20
D	4.85	4.95	4.90
E	3.80	3.90	3.85
E0	3.85	3.95	3.90
E1	5.90	6.10	6.00
e	-	-	1.27
F	2.75	3.35	3.05
H	2.11	2.71	2.41
L	0.62	0.82	0.72
N	-	-	0.35
Q	0.60	0.70	0.65
All Dimensions in mm			

Suggested Pad Layout

Please see AP02001 at <http://www.diodes.com/datasheets/ap02001.pdf> for the latest version.

(1) SO-8

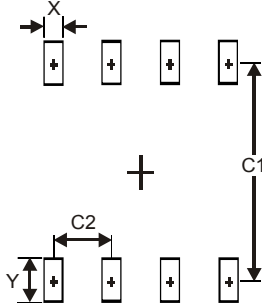

Dimensions	Value (in mm)
X	0.60
Y	1.55
C1	5.4
C2	1.27

(2) SO-8EP

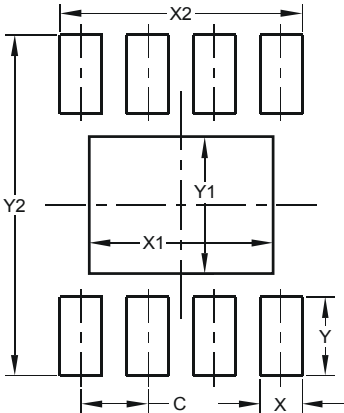

Dimensions	Value (in mm)
C	1.270
X	0.802
X1	3.502
X2	4.612
Y	1.505
Y1	2.613
Y2	6.500

IMPORTANT NOTICE

DIODES INCORPORATED MAKES NO WARRANTY OF ANY KIND, EXPRESS OR IMPLIED, WITH REGARDS TO THIS DOCUMENT, INCLUDING, BUT NOT LIMITED TO, THE IMPLIED WARRANTIES OF MERCHANTABILITY AND FITNESS FOR A PARTICULAR PURPOSE (AND THEIR EQUIVALENTS UNDER THE LAWS OF ANY JURISDICTION).

Diodes Incorporated and its subsidiaries reserve the right to make modifications, enhancements, improvements, corrections or other changes without further notice to this document and any product described herein. Diodes Incorporated does not assume any liability arising out of the application or use of this document or any product described herein; neither does Diodes Incorporated convey any license under its patent or trademark rights, nor the rights of others. Any Customer or user of this document or products described herein in such applications shall assume all risks of such use and will agree to hold Diodes Incorporated and all the companies whose products are represented on Diodes Incorporated website, harmless against all damages.

Diodes Incorporated does not warrant or accept any liability whatsoever in respect of any products purchased through unauthorized sales channel. Should Customers purchase or use Diodes Incorporated products for any unintended or unauthorized application, Customers shall indemnify and hold Diodes Incorporated and its representatives harmless against all claims, damages, expenses, and attorney fees arising out of, directly or indirectly, any claim of personal injury or death associated with such unintended or unauthorized application.

Products described herein may be covered by one or more United States, international or foreign patents pending. Product names and markings noted herein may also be covered by one or more United States, international or foreign trademarks.

This document is written in English but may be translated into multiple languages for reference. Only the English version of this document is the final and determinative format released by Diodes Incorporated.

LIFE SUPPORT

Diodes Incorporated products are specifically not authorized for use as critical components in life support devices or systems without the express written approval of the Chief Executive Officer of Diodes Incorporated. As used herein:

A. Life support devices or systems are devices or systems which:

1. are intended to implant into the body, or
2. support or sustain life and whose failure to perform when properly used in accordance with instructions for use provided in the labeling can be reasonably expected to result in significant injury to the user.

B. A critical component is any component in a life support device or system whose failure to perform can be reasonably expected to cause the failure of the life support device or to affect its safety or effectiveness.

Customers represent that they have all necessary expertise in the safety and regulatory ramifications of their life support devices or systems, and acknowledge and agree that they are solely responsible for all legal, regulatory and safety-related requirements concerning their products and any use of Diodes Incorporated products in such safety-critical, life support devices or systems, notwithstanding any devices- or systems-related information or support that may be provided by Diodes Incorporated. Further, Customers must fully indemnify Diodes Incorporated and its representatives against any damages arising out of the use of Diodes Incorporated products in such safety-critical, life support devices or systems.

Copyright © 2014, Diodes Incorporated

www.diodes.com

Looking for pricing, stock, or lifecycle information?

Click below to explore more details on WIN SOURCE:

-  [View AL9910-5S-13 on WIN SOURCE](#)
-  [Diodes Incorporated Information](#)

Optimize Your Supply Chain with WIN SOURCE Solutions

-  Global Sourcing Solution
-  Obsolete Management
-  Cost Control Management
-  Shortage Management
-  Alternative Solution
-  Excess Inventory Management