

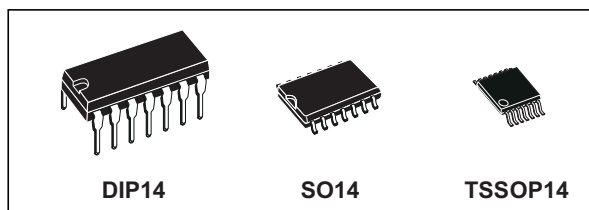

**THE DATASHEET OF
M74HC04TTR**





Description

The M74HC04 is a high-speed CMOS hex inverter manufactured using silicon gate C²MOS technology.

The internal circuit is composed of 3 stages including a buffer output which enables high noise immunity and stable output.

All inputs are equipped with protection circuits to guard against static discharge and transient excess voltage.

Features

- High speed:
 $t_{PD} = 8 \text{ ns (typ.) at } V_{CC} = 6 \text{ V}$
- Low power dissipation:
 $I_{CC} = 1 \mu\text{A (max.) at } T_A = 25 \text{ }^\circ\text{C}$
- High noise immunity:
 $V_{NIH} = V_{NIL} = 28\% V_{CC} \text{ (min.)}$
- Symmetrical output impedance:
 $|I_{OH}| = I_{OL} = 4 \text{ mA (min) at } V_{CC} = 4.5 \text{ V}$
- Balanced propagation delays:
 $t_{PLH} @ t_{PHL}$
- Wide operating voltage range:
 $V_{CC} \text{ (OPR)} = 2 \text{ V to } 6 \text{ V}$
- Pin and function compatible with 74 series 04
- ESD performance
 - CDM: 1 kV
 - HBM: 2 kV
 - MM: 200 V

Table 1. Device summary

Order code	Temperature range	Package	Packaging	Marking
M74HC04B1R	-55 °C to +125 °C	DIP14	Tube	M74HC04B1
M74HC04YRM13TR ⁽¹⁾	-40 °C to +125 °C	SO14 (automotive grade)	Tape and reel	74HC04Y
M74HC04RM13TR	-55 °C to +125 °C	SO14	Tape and reel	74HC04
M74HC04TTR	-55 °C to +125 °C	TSSOP14	Tape and reel	HC04
M74HC04YTTR ⁽¹⁾	-40 °C to +125 °C	TSSOP14 (automotive grade)	Tape and reel	HC04Y

1. Qualification and characterization according to AEC Q100 and Q003 or equivalent, advanced screening according to AEC Q001 and Q002 or equivalent.

Contents

1	Pin information	3
2	Functional description	4
3	Electrical characteristics	5
4	Package information	9
	4.1 DIP14 package information	9
	4.2 SO14 package information	10
	4.3 TSSOP14 package information	11
5	Revision history	12

1 Pin information

Figure 1. Pin connections and IEC logic symbols

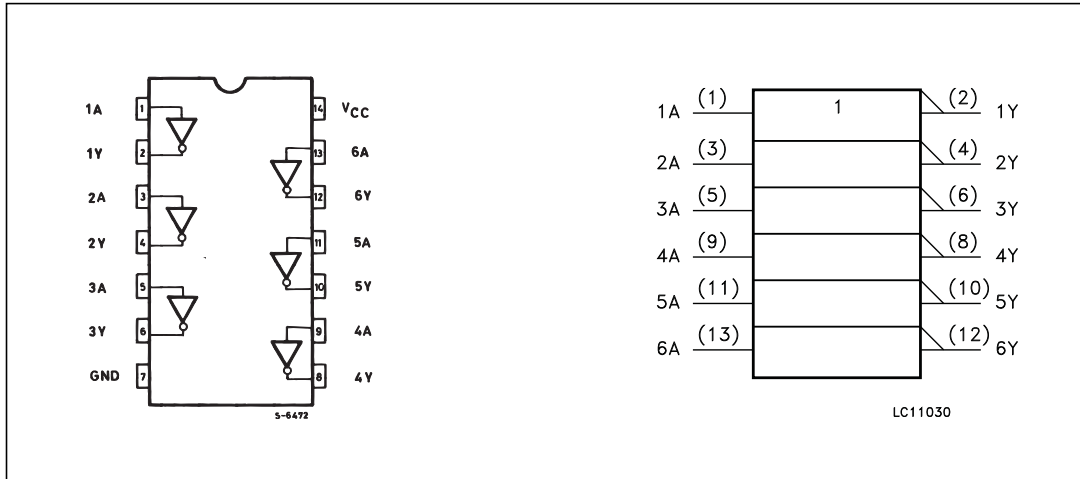

Table 2. Pin description

Pin number	Symbol	Name and function
1, 3, 5, 9, 11, 13	1A to 6A	Data inputs
2, 4, 6, 8, 10, 12	1Y to 6Y	Data outputs
7	GND	Ground (0 V)
14	V _{CC}	Positive supply voltage

2 Functional description

Table 3. Truth table

A	Y
L	H
H	L

Figure 2. Input and output equivalent circuit

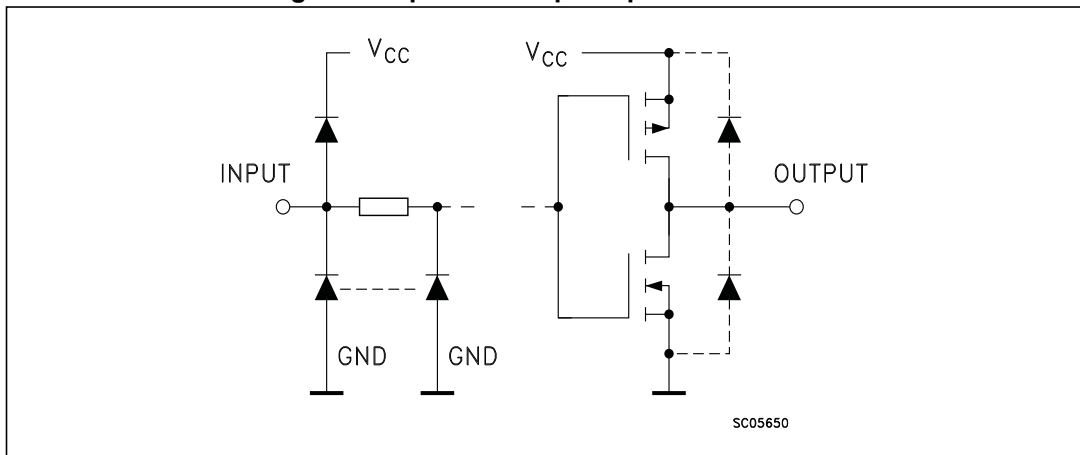

3 Electrical characteristics

Stressing the device above the ratings listed in the “Absolute maximum ratings” table may cause permanent damage to the device. These are stress ratings only, and operation of the device at these or any other conditions above those indicated in the operating sections of this specification are not implied. Exposure to absolute maximum rating conditions for extended periods may affect device reliability.

Table 4. Absolute maximum ratings

Symbol	Parameter	Value	Unit
V_{CC}	Supply voltage	-0.5 to +7	V
V_I	DC input voltage	-0.5 to $V_{CC} + 0.5$	V
V_O	DC output voltage	-0.5 to $V_{CC} + 0.5$	V
I_{IK}	DC input diode current	± 20	mA
I_{OK}	DC output diode current	± 20	mA
I_O	DC output current	± 25	mA
I_{CC} or I_{GND}	DC V_{CC} or ground current	± 50	mA
P_D	Power dissipation	500 ⁽¹⁾	mW
T_{stg}	Storage temperature	-65 to +150	°C
T_L	Lead temperature (10 sec)	300	°C

1. 500 mW at 65 °C; derate to 300 mW by 10 mW/°C from 65 °C to 85 °C

Table 5. Recommended operating conditions

Symbol	Parameter	Value	Unit	
V_{CC}	Supply voltage	2 to 6	V	
V_I	Input voltage	0 to V_{CC}	V	
V_O	Output voltage	0 to V_{CC}	V	
T_{op}	Operating temperature	-55 to 125	°C	
t_r , t_f	Input rise and fall time	$V_{CC} = 2.0$ V	0 to 1000	ns
		$V_{CC} = 4.5$ V	0 to 500	ns
		$V_{CC} = 6.0$ V	0 to 400	ns

Table 6. DC specifications

Symbol	Parameter	Test condition		Value						Unit	
		V _{CC} (V)		T _A = 25°C			-40 to 85°C		-55 to 125°C		
				Min.	Typ.	Max.	Min.	Max.	Min.		Max.
V _{IH}	High-level input voltage	2.0		1.5			1.5		1.5		V
		4.5		3.15			3.15		3.15		
		6.0		4.2			4.2		4.2		
V _{IL}	Low-level input voltage	2.0				0.5		0.5		0.5	V
		4.5				1.35		1.35		1.35	
		6.0				1.8		1.8		1.8	
V _{OH}	High-level output voltage	2.0	I _O = -20 μA	1.9	2.0		1.9		1.9		V
		4.5	I _O = -20 μA	4.4	4.5		4.4		4.4		
		6.0	I _O = -20 μA	5.9	6.0		5.9		5.9		
		4.5	I _O = -4.0 mA	4.18	4.31		4.13		4.10		
		6.0	I _O = -5.2 mA	5.68	5.8		5.63		5.60		
V _{OL}	Low-level output voltage	2.0	I _O = 20 μA		0.0	0.1		0.1		0.1	V
		4.5	I _O = 20 μA		0.0	0.1		0.1		0.1	
		6.0	I _O = 20 μA		0.0	0.1		0.1		0.1	
		4.5	I _O = 4.0 mA		0.17	0.26		0.33		0.40	
		6.0	I _O = 5.2 mA		0.18	0.26		0.33		0.40	
I _I	Input leakage current	6.0	V _I = V _{CC} or GND			± 0.1		± 1		± 1	μA
I _{CC}	Quiescent supply current	6.0	V _I = V _{CC} or GND			1		10		20	μA

Table 7. AC electrical characteristics
($C_L = 50$ pF, input $t_r = t_f = 6$ ns)

Symbol	Parameter	Test condition		Value						Unit	
		V_{CC} (V)		$T_A = 25^\circ\text{C}$			-40 to 85°C		-55 to 125°C		
				Min.	Typ.	Max.	Min.	Max.	Min.		Max.
t_{LH} t_{HL}	Output transition time	2.0			38	75		95		110	ns
		4.5			8	15		19		22	
		6.0			6	13		16		19	
t_{PLH} t_{PHL}	Propagation delay time	2.0			45	95		120		145	ns
		4.5			9	19		24		29	
		6.0			8	16		20		25	

Table 8. Capacitive characteristics

Symbol	Parameter	Test condition		Value						Unit	
		V_{CC} (V)		$T_A = 25^\circ\text{C}$			-40 to 85°C		-55 to 125°C		
				Min.	Typ.	Max.	Min.	Max.	Min.		Max.
C_{IN}	Input capacitance	5.0			5	10		10		10	pF
C_{PD}	Power dissipation capacitance ⁽¹⁾	5.0			22						pF

1. CPD is defined as the value of the IC's internal equivalent capacitance which is calculated from the operating current consumption without load. (Refer to the test circuit). Average operating current can be obtained by the following equation:
 $I_{\text{CC(opr)}} = C_{\text{PD}} \times V_{\text{CC}} \times f_{\text{IN}} + I_{\text{CC}}/6$ (per gate)

Figure 3. Test circuit

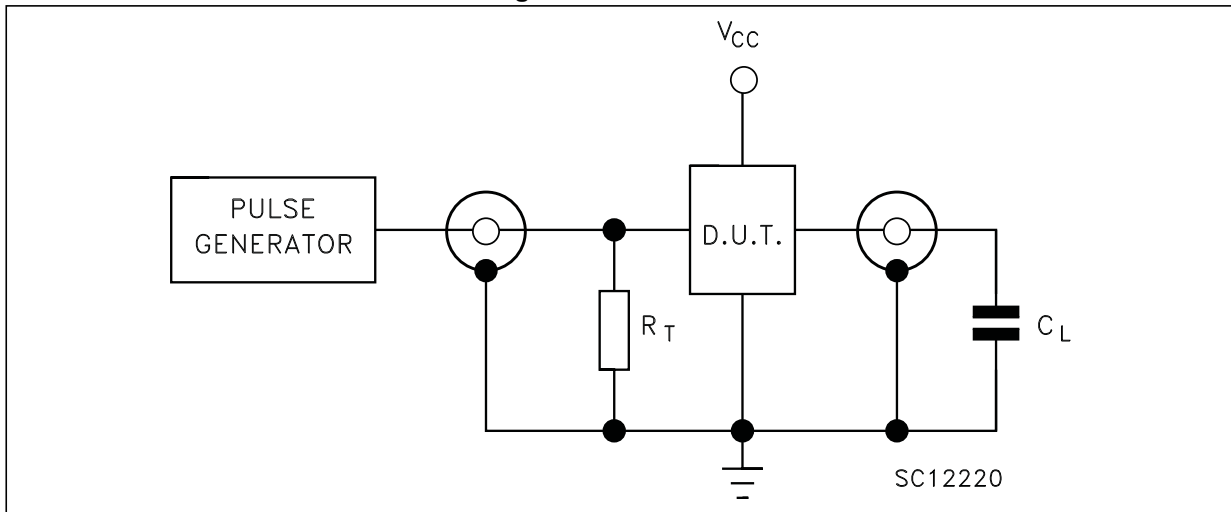
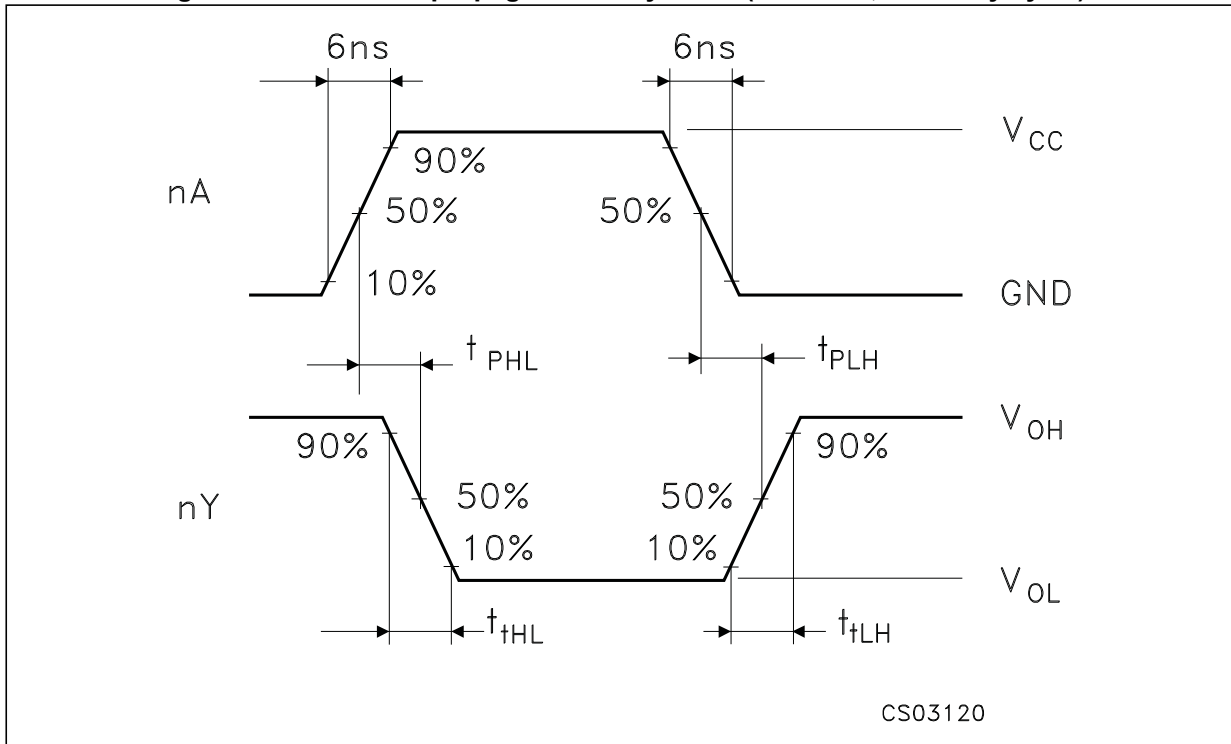

Figure 4. Waveforms: propagation delay times (f = 1 MHz; 50% duty cycle)



4 Package information

In order to meet environmental requirements, ST offers these devices in different grades of ECOPACK[®] packages, depending on their level of environmental compliance. ECOPACK[®] specifications, grade definitions and product status are available at: www.st.com. ECOPACK[®] is an ST trademark.

4.1 DIP14 package information

Figure 5. Plastic DIP14 package mechanical outline

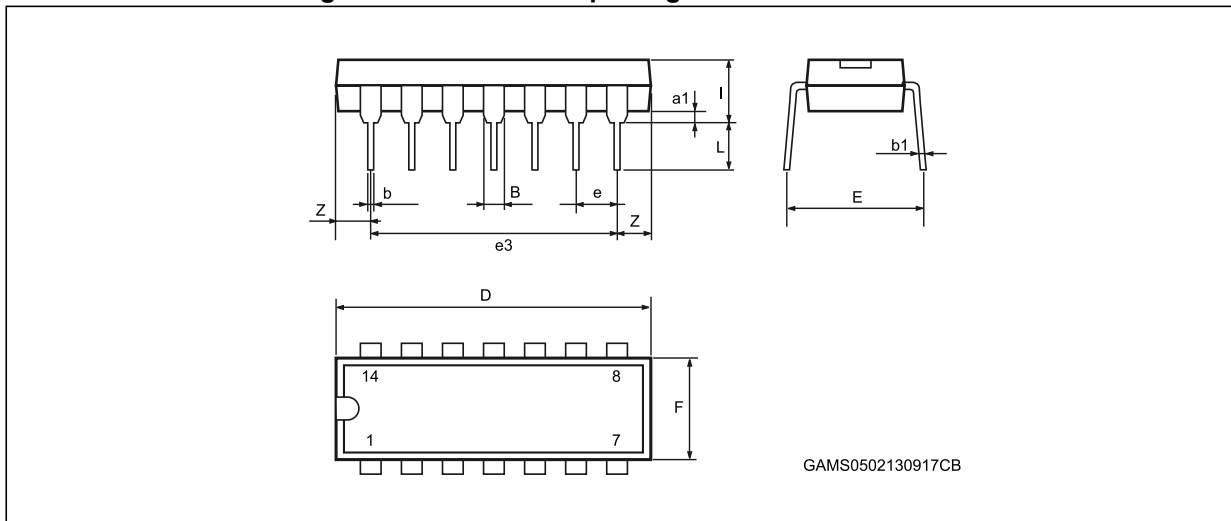

Table 9. Plastic DIP14 package mechanical data

Dimension	mm.			inches		
	Min.	Typ.	Max.	Min.	Typ.	Max.
a1	0.51			0.020		
B	1.39		1.65	0.055		0.065
b		0.5			0.020	
b1		0.25			0.010	
D			20			0.787
E		8.5			0.335	
e		2.54			0.100	
e3		15.24			0.600	
F			7.1			0.280
I			5.1			0.201
L		3.3			0.130	
Z	1.27		2.54	0.050		0.100

4.2 SO14 package information

Figure 6. Plastic SO14 package mechanical outline

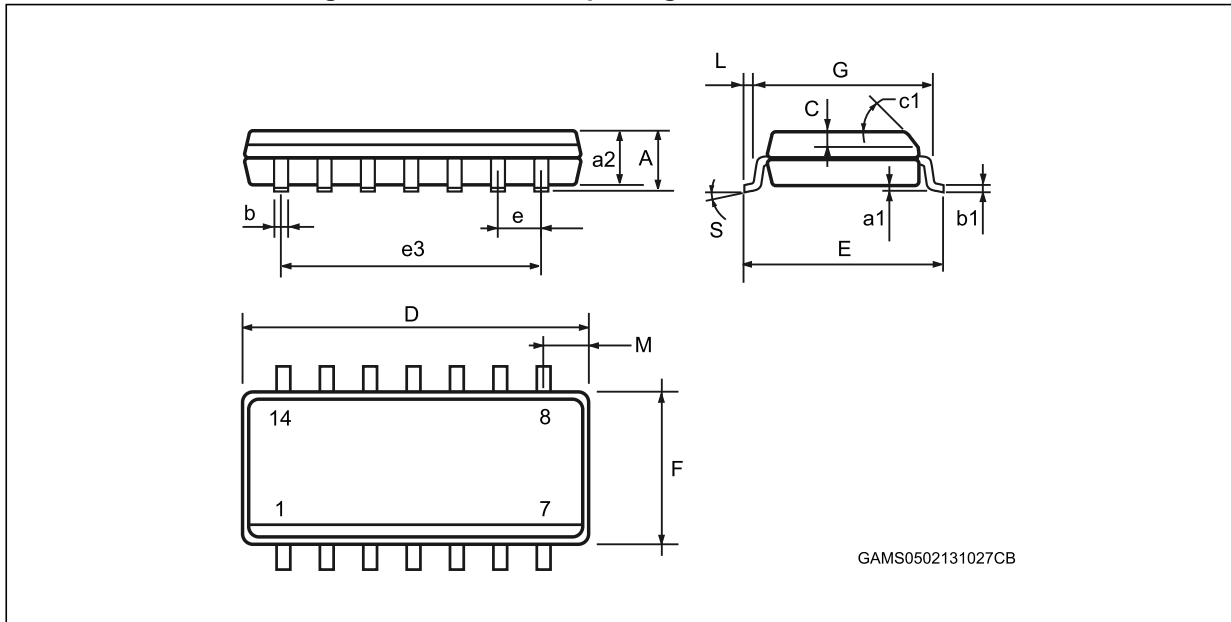

Table 10. SO14 package mechanical data

Ref.	mm.			inches		
	Min.	Typ	Max.	Min.	Typ.	Max.
A			1.75			0.068
a1	0.1		0.2	0.003		0.007
a2			1.65			0.064
b	0.35		0.46	0.013		0.018
b1	0.19		0.25	0.007		0.010
C		0.5			0.019	
c1	45° (typ.)					
D	8.55		8.75	0.336		0.344
E	5.8		6.2	0.228		0.244
e		1.27			0.050	
e3		7.62			0.300	
F	3.8		4.0	0.149		0.157
G	4.6		5.3	0.181		0.208
L	0.5		1.27	0.019		0.050
M			0.68			0.026
S	8° (max.)					

4.3 TSSOP14 package information

Figure 7. TSSOP14 package mechanical outline

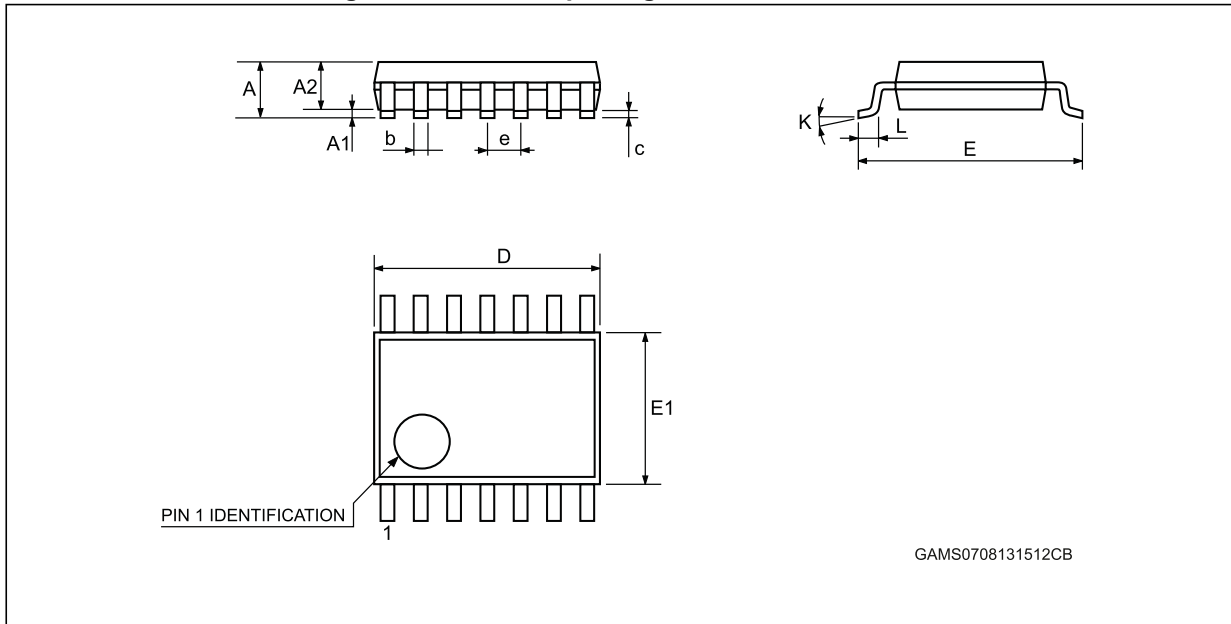

Table 11. TSSOP14 package mechanical data

Ref.	mm.			inches		
	Min.	Typ	Max.	Min.	Typ.	Max.
A			1.2			0.047
A1	0.05		0.15	0.002	0.004	0.006
A2	0.8	1	1.05	0.031	0.039	0.041
b	0.19		0.30	0.007		0.012
c	0.09		0.20	0.004		0.0089
D	4.9	5	5.1	0.193	0.197	0.201
E	6.2	6.4	6.6	0.244	0.252	0.260
E1	4.3	4.4	4.48	0.169	0.173	0.176
e		0.65 BSC			0.0256 BSC	
K	0°		8°	0°		8°
L	0.45	0.60	0.75	0.018	0.024	0.030

5 Revision history

Table 12. Document revision history

Date	Revision	Changes
11-Sep-2013	3	Added ESD information to <i>Features</i> Added automotive grade order codes, temperature ranges, and marking information to <i>Table 1: Device summary</i> Revised document presentation Minor textual updates

Please Read Carefully:

Information in this document is provided solely in connection with ST products. STMicroelectronics NV and its subsidiaries ("ST") reserve the right to make changes, corrections, modifications or improvements, to this document, and the products and services described herein at any time, without notice.

All ST products are sold pursuant to ST's terms and conditions of sale.

Purchasers are solely responsible for the choice, selection and use of the ST products and services described herein, and ST assumes no liability whatsoever relating to the choice, selection or use of the ST products and services described herein.

No license, express or implied, by estoppel or otherwise, to any intellectual property rights is granted under this document. If any part of this document refers to any third party products or services it shall not be deemed a license grant by ST for the use of such third party products or services, or any intellectual property contained therein or considered as a warranty covering the use in any manner whatsoever of such third party products or services or any intellectual property contained therein.

UNLESS OTHERWISE SET FORTH IN ST'S TERMS AND CONDITIONS OF SALE ST DISCLAIMS ANY EXPRESS OR IMPLIED WARRANTY WITH RESPECT TO THE USE AND/OR SALE OF ST PRODUCTS INCLUDING WITHOUT LIMITATION IMPLIED WARRANTIES OF MERCHANTABILITY, FITNESS FOR A PARTICULAR PURPOSE (AND THEIR EQUIVALENTS UNDER THE LAWS OF ANY JURISDICTION), OR INFRINGEMENT OF ANY PATENT, COPYRIGHT OR OTHER INTELLECTUAL PROPERTY RIGHT.

ST PRODUCTS ARE NOT AUTHORIZED FOR USE IN WEAPONS. NOR ARE ST PRODUCTS DESIGNED OR AUTHORIZED FOR USE IN: (A) SAFETY CRITICAL APPLICATIONS SUCH AS LIFE SUPPORTING, ACTIVE IMPLANTED DEVICES OR SYSTEMS WITH PRODUCT FUNCTIONAL SAFETY REQUIREMENTS; (B) AERONAUTIC APPLICATIONS; (C) AUTOMOTIVE APPLICATIONS OR ENVIRONMENTS, AND/OR (D) AEROSPACE APPLICATIONS OR ENVIRONMENTS. WHERE ST PRODUCTS ARE NOT DESIGNED FOR SUCH USE, THE PURCHASER SHALL USE PRODUCTS AT PURCHASER'S SOLE RISK, EVEN IF ST HAS BEEN INFORMED IN WRITING OF SUCH USAGE, UNLESS A PRODUCT IS EXPRESSLY DESIGNATED BY ST AS BEING INTENDED FOR "AUTOMOTIVE, AUTOMOTIVE SAFETY OR MEDICAL" INDUSTRY DOMAINS ACCORDING TO ST PRODUCT DESIGN SPECIFICATIONS. PRODUCTS FORMALLY ESCC, QML OR JAN QUALIFIED ARE DEEMED SUITABLE FOR USE IN AEROSPACE BY THE CORRESPONDING GOVERNMENTAL AGENCY.

Resale of ST products with provisions different from the statements and/or technical features set forth in this document shall immediately void any warranty granted by ST for the ST product or service described herein and shall not create or extend in any manner whatsoever, any liability of ST.

ST and the ST logo are trademarks or registered trademarks of ST in various countries.

Information in this document supersedes and replaces all information previously supplied.

The ST logo is a registered trademark of STMicroelectronics. All other names are the property of their respective owners.

© 2013 STMicroelectronics - All rights reserved

STMicroelectronics group of companies

Australia - Belgium - Brazil - Canada - China - Czech Republic - Finland - France - Germany - Hong Kong - India - Israel - Italy - Japan - Malaysia - Malta - Morocco - Philippines - Singapore - Spain - Sweden - Switzerland - United Kingdom - United States of America

www.st.com



Looking for pricing, stock, or lifecycle information?

Click below to explore more details on WIN SOURCE:

-  [View M74HC04TTR](#) on WIN SOURCE
-  [STMicroelectronics](#) Information

Optimize Your Supply Chain with WIN SOURCE Solutions

-  Global Sourcing Solution
-  Obsolete Management
-  Cost Control Management
-  Shortage Management
-  Alternative Solution
-  Excess Inventory Management