



**THE DATASHEET OF
NCV7701DWR2**



NCV7701

2.0 Amp H-Bridge Driver

This automotive grade H-Bridge driver provides a flexible means for controlling loads requiring bidirectional drive currents. Bridge outputs are protected from overcurrent at each switch and overtemperature shutdown provides product robustness. The NCV7701 inputs can be interfaced to a range of voltages, including vehicle battery voltage. The product features a low quiescent current mode, allowing unswitched connection to the power source. The NCV7701 is produced using ON Semiconductor's POWERSENSE™ BCD technology.

Features

- Forward, Reverse, Brake High, Brake Low Modes
- 1.0 A Output Current Capability (DC)
- Supply Voltage Range 7.0 V to 26 V
- 0.25 Ω $R_{DS(ON)}$ per Driver @ 25°C
- Sleep Mode ($I_Q < 10 \mu A$)
- Overvoltage Protection
- Thermal Protection
- Undervoltage Disable Function
- Short Circuit Protection
- Cross Conduction Protection
- Synchronous Low-Side Rectification for Lower Power Dissipation
- Diagnostic Output (Open Drain)
- TTL/CMOS/Pull-Up to Battery Compatible Inputs
- 20 Lead SO Package with 8 Internally Fused Leads

Typical Applications

- DC Motors
- Stepper Motors
- Modulator Valves



ON Semiconductor®

<http://onsemi.com>

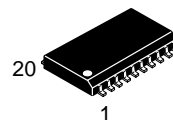

SO-20L
DW SUFFIX
CASE 751D

MARKING DIAGRAM

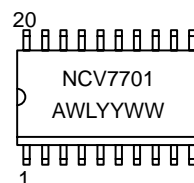

A = Assembly Location
WL, L = Wafer Lot
YY, Y = Year
WW, W = Work Week

PIN CONNECTIONS

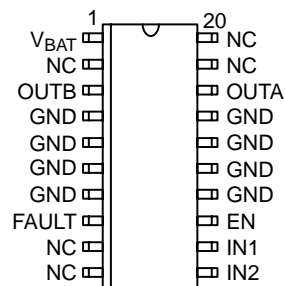

ORDERING INFORMATION

Device	Package	Shipping†
NCV7701DW	SO-20L	37 Units/Rail
NCV7701DWR2	SO-20L	1000 Tape & Reel

†For information on tape and reel specifications, including part orientation and tape sizes, please refer to our Tape and Reel Packaging Specifications Brochure, BRD8011/D.

NCV7701

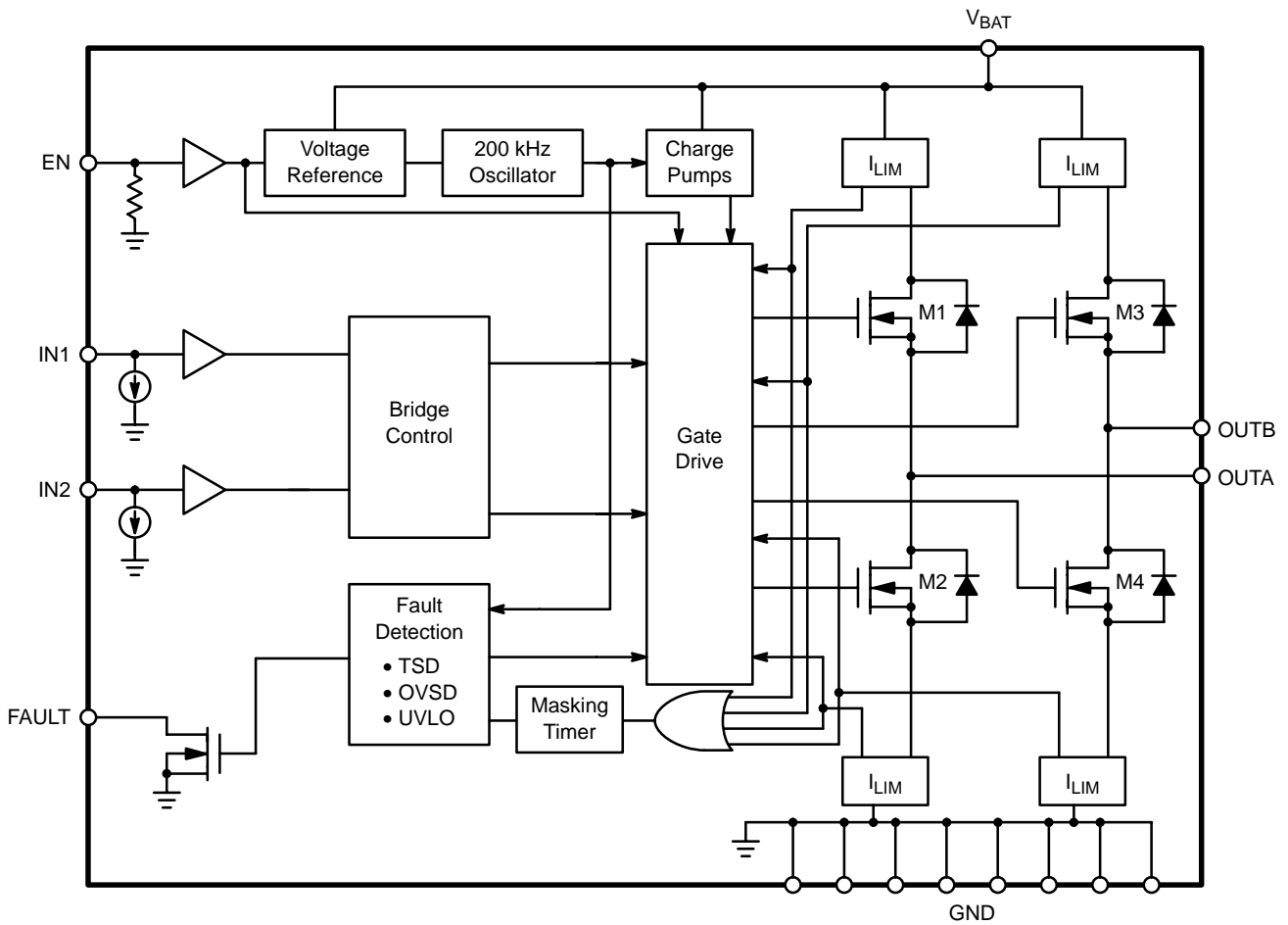

Figure 1. Block Diagram

MAXIMUM RATINGS*

Rating	Value	Unit
Supply Voltage (DC) – V_{BAT} (Note 1)	-0.3 to 45	V
Logic Input Voltage (DC)	-0.3 to 12	V
Junction Temperature Range	-40 to 150	°C
Storage Temperature Range	-65 to 150	°C
Peak Transient (1.0 ms rise time, 300 ms period, 31 V Load Dump @ $V_{BAT} = 14$ V) (Note 1)	45	V
ESD Susceptibility (Human Body Model)	2.0	kV
Package Thermal Resistance Junction-to-Case, $R_{\theta JC}$ Junction-to-Ambient, $R_{\theta JA}$	9.0 55	°C/W °C/W
Lead Temperature Soldering:	Reflow: (SMD styles only) (Note 2)	230 peak °C

*The maximum package power dissipation must be observed.

1. External reverse-battery and transient voltage suppression (TVS) required.
2. 60 second maximum above 183°C.

NCV7701

ELECTRICAL CHARACTERISTICS (7.0 V ≤ V_{BAT} ≤ 26 V, -40°C ≤ T_J ≤ 125°C; unless otherwise specified.) Note 3.

Characteristic	Test Conditions	Min	Typ	Max	Unit
----------------	-----------------	-----	-----	-----	------

General

V _{BAT} Quiescent Current:					
Low Quiescent	EN = 0 V, V _{BAT} ≤ 12.8 V	-	-	10	μA
Normal Operation	2.5 V ≤ EN ≤ V _{BAT} , V _{BAT} = 14 V	-	-	8.0	mA

EN Logic Input

Low Level Input Voltage	-	-	-	0.7	V
High Level Input Voltage	-	2.5	-	-	V
Input Bias Current	EN = 5.0 V	15	50	100	μA
Input Leakage Current	EN = 0 V	-	-	1.0	μA

IN1, IN2, Logic Inputs

Low Level Input Voltage	-	-	-	0.8	V
High Level Input Voltage	-	2.0	-	-	V
Input Bias Current	5.0 V on Logic Input, EN = 5.0 V	5.0	20	40	μA
Input Leakage Current	0 V on Logic Input, EN = 0 V	-	-	1.0	μA

IC Protection

Overvoltage Shutdown	-	27	32	37	V
Overvoltage Hysteresis	-	0.2	0.5	1.0	V
Undervoltage Voltage Lockout	-	-	-	6.5	V
Undervoltage Hysteresis	-	100	200	400	mV
Thermal Shutdown	(Guaranteed by Design)	160	185	210	°C
Thermal Hysteresis	(Guaranteed by Design)	10	22.5	35	°C

Drivers OUTA, OUTB

Output High Voltage (V _H)	V _{BAT} = 14 V, I _{SOURCE} = 1.0 A, V _H = V _{BAT} - OUT _X	-	0.4	0.75	V
Output Low Voltage (V _L)	V _{BAT} = 14 V, I _{SOURCE} = 1.0 A, V _L = OUT _X - V _{GND}	-	0.4	0.75	V
Current Limit	V _{BAT} = 14 V	3.0	4.0	5.0	A

FAULT Output

Output Leakage Current	V _{FAULT} = 5.0 V, Fault Absent	-	-	10	μA
Output Low Voltage	I _{FAULT} = 0.5 mA, Fault Present	-	-	1.0	V

AC Characteristics

Output Turn-On Delay	-	-	5.0	10	μs
Output Turn-Off Delay	-	-	5.0	10	μs
Current Limit Mask Time	-	20	40	60	μs

3. Designed to meet these characteristics over the stated voltage and temperature ranges, though may not be 100% parametrically tested in production.

NCV7701

Table 1. H-Bridge Mode Control

EN	IN1	IN2	H-Bridge	OUTA	OUTB
0	X	X	Off (Sleep Mode)	Off	Off
1	0	0	Brake Low	Low	Low
1	0	1	Forward	High	Low
1	1	0	Reverse	Low	High
1	1	1	Brake High	High	High

Table 2. Fault Diagnostics

Fault Condition	Fault Pin	H-Bridge
No Faults	High Z	Normal Operation
Undervoltage	Low	Off
Overvoltage	Low	Off
Thermal Shutdown	Low	Off
Current Limit	Low	1 or more Drivers in Current Limit

PACKAGE PIN DESCRIPTION

Pin No.	Symbol	Description
1	V _{BAT}	IC supply voltage.
2, 9, 10, 19, 20	NC	No connection.
3	OUTB	Bridge output.
4, 5, 6, 7, 14, 15, 16, 17	GND	Power ground.
8	FAULT	Diagnostic output.
11	IN2	Mode control input.
12	IN1	Mode control input.
13	EN	Chip enable.
18	OUTA	Bridge output.

Operating Description

During power up, the outputs are HI-Z regardless of the input states. When the undervoltage lockout threshold is exceeded, the outputs will reflect the input states. Outputs change to HI-Z whenever an undervoltage, overvoltage or thermal shutdown fault is detected. Normal operation will resume when faults are resolved.

Overcurrent Protection

Current is monitored continuously in each switch of each half bridge when the ENA input is in a high state thus protecting each switch from faults due to short to GND, short to V_{BAT} or shorted load conditions. Only the affected

half-bridge is disabled for short to V_{BAT} or short to GND faults. A mask timer is initiated after a fault is detected and prevents recognition of an overcurrent event until the mask time expires. Persistence of an overcurrent condition causes the bridge output to change to HI-Z and the FAULT output to latch low until the next transition occurs on either the input related to the faulted output or the ENA input is brought low then high again. This method of protection provides current limiting on a cycle-by-cycle basis and helps allow a stall torque current to be ignored during motor start. Continued overcurrent may eventually result in activation of the thermal shutdown circuitry, thus activating a second level of protection for the NCV7701.

NCV7701

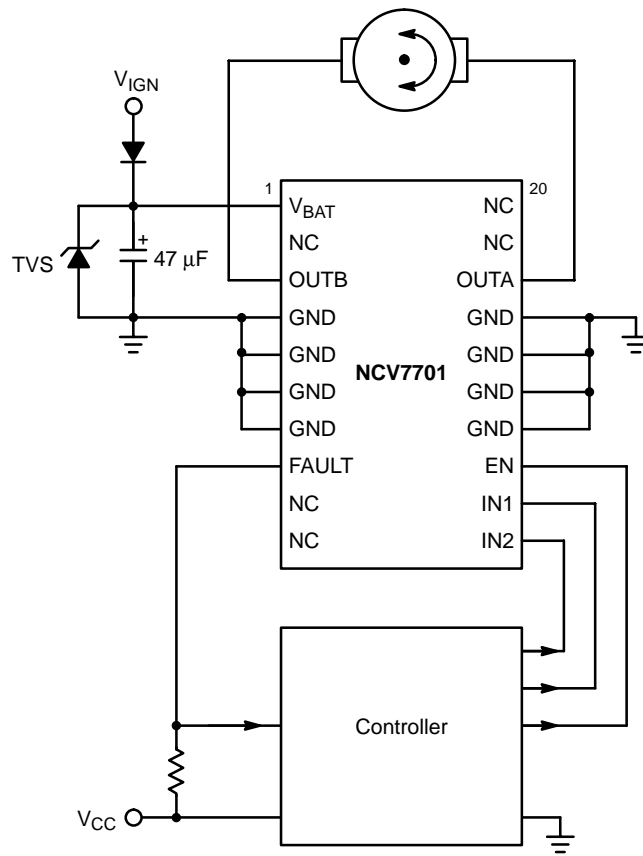
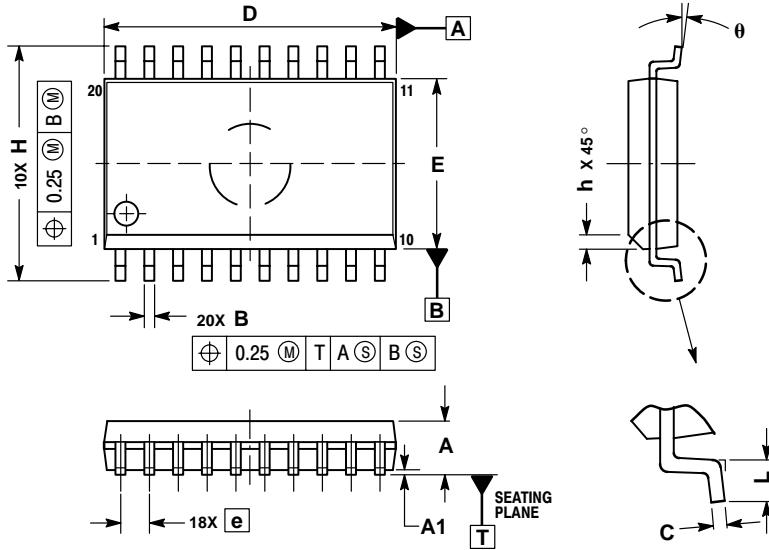

Figure 2. Application Diagram

NCV7701

PACKAGE DIMENSIONS

SO-20L
DW SUFFIX
CASE 751D-05
ISSUE F



NOTES:

1. DIMENSIONS ARE IN MILLIMETERS.
2. INTERPRET DIMENSIONS AND TOLERANCES PER ASME Y14.5M, 1994.
3. DIMENSIONS D AND E DO NOT INCLUDE MOLD PROTRUSION.
4. MAXIMUM MOLD PROTRUSION 0.15 PER SIDE.
5. DIMENSION B DOES NOT INCLUDE DAMBAR PROTRUSION. ALLOWABLE PROTRUSION SHALL BE 0.13 TOTAL IN EXCESS OF B DIMENSION AT MAXIMUM MATERIAL CONDITION.

DIM	MILLIMETERS	
	MIN	MAX
A	2.35	2.65
A1	0.10	0.25
B	0.35	0.49
C	0.23	0.32
D	12.65	12.95
E	7.40	7.60
e	1.27 BSC	
H	10.05	10.55
h	0.25	0.75
L	0.50	0.90
θ	0°	7°

POWERSENSE is a trademark of Semiconductor Components Industries, LLC.

ON Semiconductor and are registered trademarks of Semiconductor Components Industries, LLC (SCILLC). SCILLC reserves the right to make changes without further notice to any products herein. SCILLC makes no warranty, representation or guarantee regarding the suitability of its products for any particular purpose, nor does SCILLC assume any liability arising out of the application or use of any product or circuit, and specifically disclaims any and all liability, including without limitation special, consequential or incidental damages. "Typical" parameters which may be provided in SCILLC data sheets and/or specifications can and do vary in different applications and actual performance may vary over time. All operating parameters, including "Typicals" must be validated for each customer application by customer's technical experts. SCILLC does not convey any license under its patent rights nor the rights of others. SCILLC products are not designed, intended, or authorized for use as components in systems intended for surgical implant into the body, or other applications intended to support or sustain life, or for any other application in which the failure of the SCILLC product could create a situation where personal injury or death may occur. Should Buyer purchase or use SCILLC products for any such unintended or unauthorized application, Buyer shall indemnify and hold SCILLC and its officers, employees, subsidiaries, affiliates, and distributors harmless against all claims, costs, damages, and expenses, and reasonable attorney fees arising out of, directly or indirectly, any claim of personal injury or death associated with such unintended or unauthorized use, even if such claim alleges that SCILLC was negligent regarding the design or manufacture of the part. SCILLC is an Equal Opportunity/Affirmative Action Employer. This literature is subject to all applicable copyright laws and is not for resale in any manner.

PUBLICATION ORDERING INFORMATION

LITERATURE FULFILLMENT:

Literature Distribution Center for ON Semiconductor
P.O. Box 5163, Denver, Colorado 80217 USA

Phone: 303-675-2175 or 800-344-3860 Toll Free USA/Canada

Fax: 303-675-2176 or 800-344-3867 Toll Free USA/Canada

Email: orderlit@onsemi.com

N. American Technical Support: 800-282-9855 Toll Free
USA/Canada

Japan: ON Semiconductor, Japan Customer Focus Center
2-9-1 Kamimeguro, Meguro-ku, Tokyo, Japan 153-0051
Phone: 81-3-5773-3850

ON Semiconductor Website: <http://onsemi.com>

Order Literature: <http://www.onsemi.com/litorder>

For additional information, please contact your
local Sales Representative.

Looking for pricing, stock, or lifecycle information?

Click below to explore more details on WIN SOURCE:

 [View NCV7701DWR2](#) on WIN SOURCE

 [ON Semiconductor](#) Information

Optimize Your Supply Chain with WIN SOURCE Solutions

-  Global Sourcing Solution
-  Obsolete Management
-  Cost Control Management
-  Shortage Management
-  Alternative Solution
-  Excess Inventory Management