Description

The MT90863 Rate Conversion Switch provides switching capacities of $2,048 \times 512$ channels between backplane and local streams, and 512×512 channels for local streams. The connected serial inputs and outputs may have 32, 64 and 128 64 kb/s channels per frame with data rates of 2.048 Mb/s, 4.096 Mb/s and 8.192 Mb/s respectively.

The MT90863 also offers a sub-rate switching configuration which allows 2-bit wide 16 kb/s data channels to be switched within the device.

The device has features (such as: message mode; input and output offset delay; direction control; and, high impedance output control) that are programmable on per-stream or per-channel basis.

Change Summary

Changes from the May 2006 issue to the September 2011 issue.

Page	Item	Change
1	Ordering Information	Removed leaded packages as per PCN notice.

Table of Contents

1.0 Device Overview	10
2.0 Functional Description	11
2.1 Frame Alignment Timing	11
3.0 Switching Configuration	11
3.1 Backplane Interface	11
3.2 Local Interface	13
3.3 Input Frame Offset Selection	13
3.4 Output Advance Offset Selection	13
3.5 Serial Input Frame Alignment Evaluation	14
3.6 Memory Block Programming	15
4.0 Delay through the MT90863	15
4.1 Variable Delay Mode (LV/C or BV/C bit = 0)	16
4.2 Constant Delay Mode (LV/C bit or BV/C= 1)	16
5.0 Microprocessor Interface	16
5.1 Memory Mapping	16
5.2 Address Buffer Mode	18
5.3 Write Operation using Address Buffer Mode	18
5.4 Read Operation using Address Buffer Mode	18
5.5 Backplane Connection Memory Control	19
5.6 Local Connection Memory Control	21
5.7 DTA Data Transfer Acknowledgment Pin	21
6.0 Initialization of the MT90863	21
7.0 JTAG Support	33
7.1 Test Access Port (TAP)	33
7.2 Instruction Register	34
7.3 Test Data Register	34

List of Figures

Figure 1 - Functional Block Diagram	1
Figure 2 - MQFP Pin Connections	6
Figure 3 - BGA Pin Connections	7
Figure 4 - ST-BUS Timing for 2, 4 and 8 Mb/s Data Streams	12
Figure 5 - CT Bus Mode Timing for 2, 4 and 8 Mb/s Data Streams	12
Figure 6 - HMOVIP Mode Timing for 2 and 8 Mb/s Data Streams	13
Figure 7 - Block Programming Data in the Connection Memories	17
Figure 8 - Example for Frame Alignment Measurement	24
Figure 9 - Examples for Input Offset Delay Timing	27
Figure 10 - Examples for Frame Output Offset Timing	28
Figure 11 - ST-BUS Timing for Stream rate of 2.048, 4.096 or 8.192 Mb/s	39
Figure 12 - CT Bus Timing for Stream rate of 2.048, 4.096 or 8.192 Mb/s	40
Figure 13 - HMOVIP Bus Timing for Stream rate of 2.048 Mb/s or 8.192 Mb/s	41
Figure 14 - Serial Output and External Control	41
Figure 15 - Output Driver Enable (ODE)	42
Figure 16 - Motorola Non-Multiplexed Bus Timing	43

List of Tables

Table 1 - Timing Signals Requirements for Various Operation Modes.	14
Table 2 - Mode Selection for Backplane interface	14
Table 4 - Address Memory Map	17
Table 5 - Output High Impedance Control	19
Table 6 - Control (CR) Register Bits.	19
Table 7 - Device Mode Selection (DMS) Register Bits.	20
Table 8 - Internal Mode Selection (IMS) Register Bits	22
Table 9 - Frame Alignment (FAR) Register Bit.	23
Table 10 - Frame Delay Offset (DOS) Register Bits.	25
Table 11 - Offset Bits (IFn2, IFn1, IFn0, DLEn) & Input Offset Bits (FD9, FD2-0)	27
Table 12 - Frame Output Offset (FOR) Register Bits	28
Table 13 - Address Buffer (ABR) Register Bits	29
Table 14 - Data Write (DWR) Register Bits	29
Table 15 - Data Read (DRR) Register Bits.	30
Table 16 - Blackplane Connection Memory Bits.	30
Table 17 - BSAB Bits Programming for Different Local Interface mode.	31
Table 18 - BCAB Bits Programming for Different Data Rates	31
Table 19 - Local Connection Memory Low Bits	31
Table 20 - LSAB Bits Programming for Different Local Interface Modes	32
Table 21 - LCAB Bits Programming for Different Data Rates.	32
Table 22 - Local Connection Memory High Bits	33
Table 23 - Boundary Scan Register Bits	34

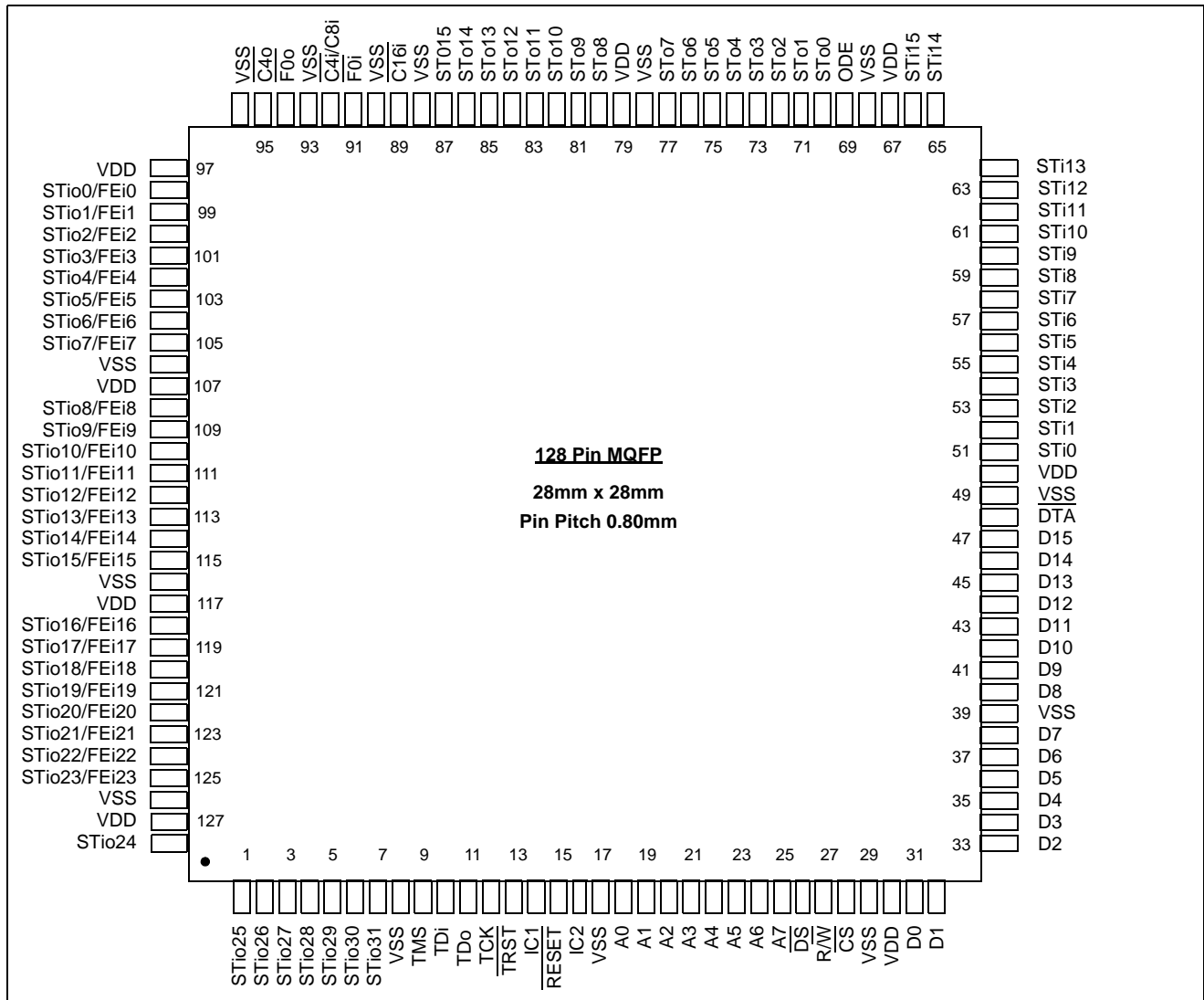

Figure 2 - MQFP Pin Connections

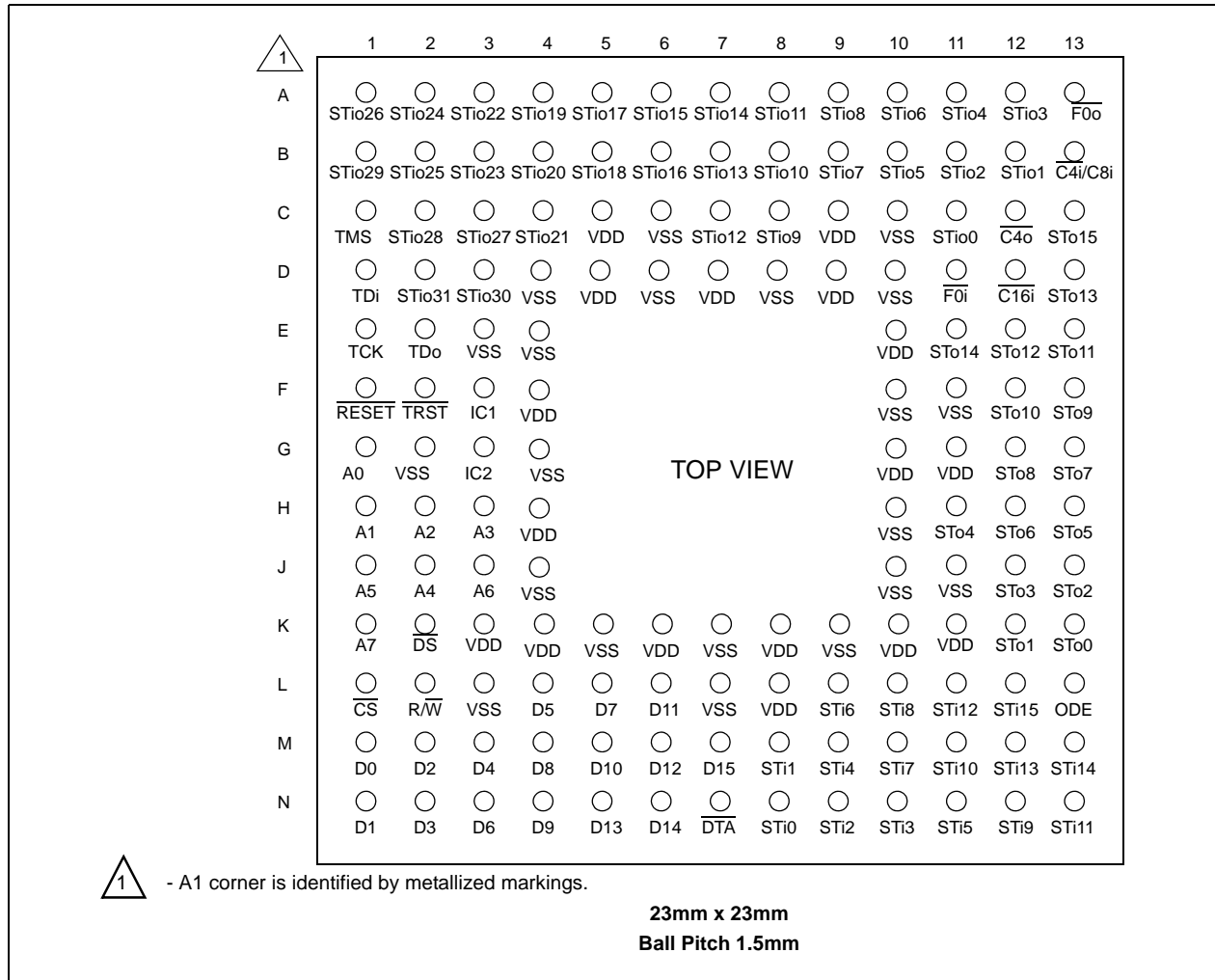

Figure 3 - BGA Pin Connections

Pin Description

128 MQFP Pin#	144 BGA Pin#	Name	Description
30,50,67, 79,97,107, 117,127	C5,C9,D5,D7, D9,E10,F4,G10 ,G11,H4, K3,K4,K6,K8 K10,K11,L8	V _{DD}	+3.3 Volt Power Supply
8,17,29,39, 49,68,78,8 8,90,93,96, 106, 116,126	C6,C10,D4,D6, D8,D10,E3,E4, F10,F11,G2, G4,H10,J4, J10,J11,K5 K7,K9,L3,L7	V _{SS}	Ground
89	D12	$\overline{C16i}$	Master Clock (5 V Tolerant Input): Serial clock for shifting data in/out on the serial streams. This pin accepts a 16.384 MHz clock.
91	D11	$\overline{F0i}$	Master Frame Pulse (5 V Tolerant Input): In ST-BUS mode, this input accepts a 61 ns wide negative frame pulse. In CT Bus mode, it accepts a 122 ns wide negative frame pulse. In HMVIP mode, it accepts a 244 ns wide negative frame pulse.
92	B13	$\overline{C4i/C8i}$	HMVIP/CT Bus Clock (5 V Tolerant Input): When HMVIP mode is enabled, this pin accepts a 4.096 MHz clock for HMVIP frame pulse alignment. When CT Bus mode is enabled, it accepts a 8.192 MHz clock for CT frame pulse alignment.
94	A13	$\overline{F0o}$	Frame Pulse (5 V Tolerant Output): A 244 ns wide negative frame pulse that is phase locked to the master frame pulse ($\overline{F0i}$).
95	C12	$\overline{C4o}$	C4 Clock (5 V Tolerant Output): A 4.096 MHz clock that is phase locked to the master clock ($\overline{C16i}$).
98-105, 108-115	C11, B12, B11, A12, A11, B10, A10, B9, A9, C8, B8, A8, C7, B7, A7, A6,	STio0 - 15 FEi0 - 15	Serial Input Streams 0 to 15 / Frame Evaluation Inputs 0 to 15 (5 V Tolerant I/O). In 2 Mb/s and HMVIP modes, these pins accept serial TDM data streams at 2.048 Mb/s with 32 channels per stream. In 4 Mb/s or 8 Mb/s mode, these pins accept serial TDM data streams at 4.096 or 8.192 Mb/s with 64 or 128 channels per stream respectively. In Frame Evaluation Mode (FEM), they are frame evaluation inputs.
118-125	B6, A5, B5, A4, B4, C4, A3, B3	STio16 - 23 FEi16 - 23	Serial Input Streams 16 to 23 (5 V Tolerant I/O). In 2 Mb/s or 4 Mb/s mode, these pins accept serial TDM data streams at 2.048 or 4.096 Mb/s with 32 or 64 channels per stream respectively. In HMVIP mode, these pins have a data rate of 8.192 Mb/s with 128 channels per stream. In Frame Evaluation Mode (FEM), they are frame evaluation inputs.
128, 1-7	A2, B2, A1, C3, C2, B1, D3, D2	STio24 - 31	Serial Input Streams 24 to 31 (5 V Tolerant I/O). These pins are only used for 2 Mb/s or 4 Mb/s mode. They accept serial TDM data streams at 2.048 or 4.096 Mb/s with 32 or 64 channels per stream respectively.
9	C1	TMS	Test Mode Select (3.3 V Input with internal pull-up): JTAG signal that controls the state transitions of the TAP controller.
10	D1	TDi	Test Serial Data In (3.3 V Input with internal pull-up): JTAG serial test instructions and data are shifted in on this pin.

Pin Description (continued)

128 MQFP Pin#	144 BGA Pin#	Name	Description
11	E2	TDo	Test Serial Data Out (3.3 V Output): JTAG serial data is output on this pin on the falling edge of TCK. This pin is held in a high impedance state when JTAG scan is not enabled.
12	E1	TCK	Test Clock (5 V Tolerant Input): Provides the clock to the JTAG test logic.
13	F2	$\overline{\text{TRST}}$	Test Reset (3.3 V Input with internal pull-up): Asynchronously initializes the JTAG TAP controller by putting it in the Test-Logic-Reset state. This pin should be pulsed low on power-up, or held low continuously, to ensure that the MT90863 is in the normal operation mode.
14	F3	IC1	Internal Connection 1 (3.3 V Input with internal pull-down): Connect to V_{SS} for normal operation.
15	F1	$\overline{\text{RESET}}$	Device Reset (5 V Tolerant Input): This input (active LOW) puts the MT90863 in its reset state. This clears the device's internal counters and registers.
16	G3	IC2	Internal Connection 2 (3.3 V Input): Connect to V_{SS} for normal operation.
18-25	G1, H1, H2, H3, J2, J1, J3, K1	A0 - A7	Address 0 - 7 (5 V Tolerant Input): These lines provide the A0 to A7 address lines to the internal memories.
26	K2	$\overline{\text{DS}}$	Data Strobe (5 V Tolerant Input): This active low input works in conjunction with $\overline{\text{CS}}$ to enable the read and write operations.
27	L2	$\overline{\text{R/W}}$	Read/Write (5 V Tolerant Input): This input controls the direction of the data bus lines (D0-D15) during a microprocessor access.
28	L1	$\overline{\text{CS}}$	Chip Select (5 V Tolerant Input): Active low input used by a microprocessor to activate the microprocessor port.
31-38, 40-47	M1, N1, M2, N2, M3, L4, N3, L5, M4, N4, M5, L6, M6, N5, N6, M7,	D0 - 7, D8 - D15	Data Bus 0 -15 (5 V Tolerant I/O): These pins form the 16-bit data bus of the microprocessor port.
48	N7	$\overline{\text{DTA}}$	Data Transfer Acknowledgment (5 V Tolerant Three-state Output): This active low output indicates that a data bus transfer is complete. A pull-up resistor is required to hold a HIGH level when the pin is tri-stated.
51-54	N8, M8, N9, N10	STi0 - 3	Serial Input Streams 0 to 3 (5 V Tolerant Inputs): In 2 Mb/s or Subrate Switching mode, these inputs accept data rates of 2.048 Mb/s with 32 channels per stream. In 8 Mb/s mode, these inputs accept data rates of 8.192 Mb/s with 128 channels per stream.
55-62	M9, N11, L9, M10, L10, N12, M11, N13	STi4 - 11	Serial Input Streams 4 to 11 (5 V Tolerant Inputs): In 2 Mb/s or Subrate Switching mode, these inputs accept data rates of 2.048 Mb/s with 32 channels per stream.

Pin Description (continued)

128 MQFP Pin#	144 BGA Pin#	Name	Description
63	L11	STi12	Serial Input Streams 12 (5 V Tolerant Input): In 2 Mb/s mode, this input accepts data rate of 2.048 Mb/s with 32 channels per stream respectively. In Sub-rate Switching mode, this pin accepts 2.048 Mb/s with 128 channels per stream for Sub-rate switching application.
64-66	M12, M13, L12	STi13 - 15	Serial Input Streams 13 to 15 (5 V Tolerant Inputs): In 2 Mb/s mode, these inputs accept a data rate of 2.048 Mb/s with 32 channels per stream.
69	L13	ODE	Output Drive Enable (5 V Tolerant Input): This is the output enable control for the STo0 to STo15 serial outputs and STio0 to STio31 serial bidirectional outputs.
70-73	K13, K12, J13, J12	STo0 - 3	Serial Output Streams 0 to 3 (5 V Tolerant Three-state Outputs): In 2 Mb/s or Sub-rate Switching mode, these outputs have data rates of 2.048 Mb/s with 32 channels per stream respectively. In 8 Mb/s mode, these outputs have data rates of 8.192 Mb/s with 128 channels per stream
74-77, 80-83	H11, H13, H12, G13, G12, F13, F12, E13	STo4 - 7, STo8 - 11	Serial Output Streams 4 to 11 (5 V Tolerant Three-state Outputs): In 2 Mb/s or Sub-rate Switching mode, these outputs have data rates of 2.048 Mb/s with 32 channels per stream
84	E12	STo12	Serial Output Streams 12 (5 V Tolerant Three-state Output): In 2 Mb/s mode, this output has data rate of 2.048 Mb/s with 32 channels per stream. In Sub-rate Switching mode, this pin has data rate of 2.048 Mb/s with 128 channels per stream for Sub-rate switching application.
85-87	D13, E11, C13	STo13 - 15	Serial Output Streams 13 to 15 (5 V Tolerant Three-state Outputs): In 2 Mb/s mode, these outputs have a data rate of 2.048 Mb/s with 32 channels per stream.

1.0 Device Overview

The Rate conversion Switch (MT90863) can switch up to $2,048 \times 512$ channels while also providing a rate conversion capability. It is designed to switch 64 kb/s PCM or $N \times 64$ kb/s data between the backplane and local interfaces. When the device is in the sub-rate switching mode, 2-bit wide 16 kb/s data channels can be switched within the device. The device maintains frame integrity in data applications and minimum throughput delay for voice application on a per channel basis.

The backplane interface can operate at 2.048, 4.096 or 8.192 Mb/s, arranged in 125 μ s wide frames that contain 32, 64 or 128 channels, respectively. A built-in rate conversion circuit allows users to interface between backplane interface and the local interface which operates at 2.048 Mb/s or 8.192 Mb/s.

By using Zarlink's message mode capability, the microprocessor can access input and output time-slots on a per channel basis. This feature is useful for transferring control and status information for external circuits or other ST-BUS devices.

The frame offset calibration function allows users to measure the frame offset delay for streams STio0 to STio23. The offset calibration is activated by a frame evaluation bit in the frame evaluation register. The evaluation result is stored in the frame evaluation registers and can be used to program the input offset delay for individual streams using internal frame input offset registers.

2.0 Functional Description

A functional Block Diagram of the MT90863 is shown in Figure 1. One end of the MT90863 is used to interface with backplane applications, such as HMVIP or H.100 environments, while the other end supports the local switching environments.

2.1 Frame Alignment Timing

The Device Mode Selection (DMS) register allows users to select three different frame alignment timing modes. In ST-BUS modes, the master clock ($\overline{C16i}$) is always at 16.384 MHz. The frame pulse ($\overline{F0i}$) input accepts a negative frame pulse at 8 kHz. The frame pulse goes low at the frame boundary for 61 ns. The frame pulse output $F0o$ provides a 244 ns wide negative frame pulse and the $\overline{C4o}$ output provides a 4.094 MHz clock. These two signals are used to support local switching applications. See Figure 4 for the ST-BUS timings.

In CT Bus mode, the $\overline{C4i}/C8i$ pin accepts 8.192 MHz clock for the CT Bus frame pulse alignment. The $\overline{F0i}$ is the CT bus frame pulse input. The CT frame pulse goes low at the frame boundary for 122 ns. See Figure 5 for the CT Bus timing.

In HMVIP mode, the $\overline{C4i}/C8i$ pin accepts 4.096 MHz clock for the HMVIP frame pulse alignment. The $\overline{F0i}$ is the HMVIP frame pulse input. The HMVIP frame pulse goes low at the frame boundary for 244 ns. See Figure 6 for the HMVIP timing.

Table 1 - describes the input timing requirements for ST-BUS, CT Bus and HMVIP modes.

3.0 Switching Configuration

The device has four operation modes for the backplane interface and three operation modes for the local interface. These modes can be programmed via the Device Mode Selection (DMS) register. Mode selections between the backplane and local interfaces are independent. See Table 2 and Table 3 for the selection of various operation modes via the programming of the DMS register.

3.1 Backplane Interface

The backplane interface can be programmed to accept data streams of 2 Mb/s, 4 Mb/s or 8 Mb/s. When 2 Mb/s mode is enabled, STio0 to STio31 have a data rate of 2.048 Mb/s. When 4 Mb/s mode is enabled, STio0 to STio31 have a data rate of 4.096 Mb/s. When 8 Mb/s mode is enabled, STio0 to STio15 have a data rate of 8.192 Mb/s. When HMVIP mode is enabled, STio0 to STio15 have a data rate of 2.048 Mb/s and STio16 to STio23 have a data rate of 8.192 Mb/s. Table 2 describes the data rates and mode selection for the backplane interface.

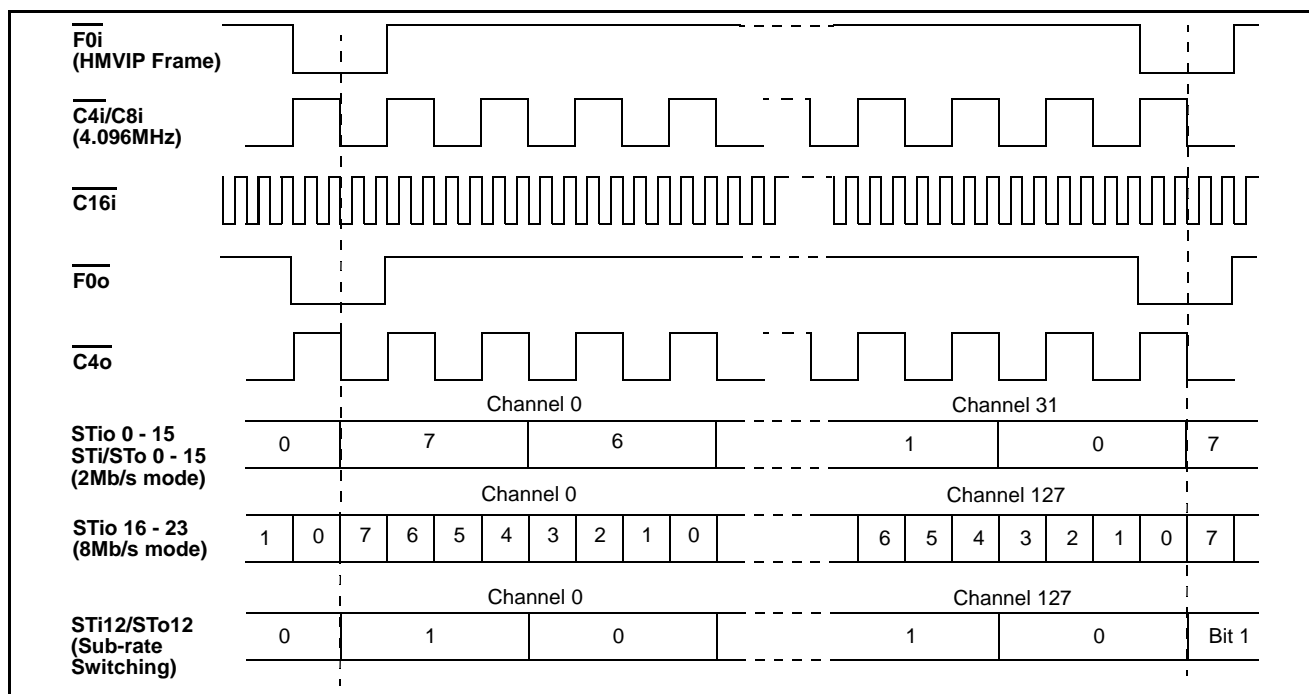

Figure 6 - HMVIP Mode Timing for 2 and 8 Mb/s Data Streams

3.2 Local Interface

Three operation modes, 2 Mb/s, 8 Mb/s and Sub-rate Switching mode, can be selected for the local interface. When 2 Mb/s mode is selected, STi0 to STi15 and STo0 to STo15 have a 2.048 Mb/s data rate. When 8 Mb/s mode is selected, STi0 to STi3 and STo0 to STo3 have an 8.192 Mb/s data rate. When Sub-rate Switching mode is selected, STi0 to STi11 and STo0 to STo11 have 2.048 Mb/s data with 64 kb/s data channels and STi12 and STo12 have a 2.048 Mb/s data rate with 16 kb/s data channels. Table 3 describes the data rates and mode selection for the local interface.

3.3 Input Frame Offset Selection

Input frame offset selection allows the channel alignment of individual backplane input streams, that operate at 8.192 Mb/s (STi0-23), to be shifted against the input frame pulse (F0i). This feature compensates for the variable path delays caused by serial backplanes of variable length. Such delays can occur in large centralized and distributed switching systems.

Each backplane input stream can have its own delay offset value by programming the input delay offset registers (DOS0 to DOS5). Possible adjustment can range up to +4 master clock (C16i) periods forward with resolution of half master clock period. See Table 10 and Table 11, and Figure 9, Figure 9 - for frame input delay offset programming.

3.4 Output Advance Offset Selection

The MT90863 allows users to advance individual backplane output streams which operate at 8.192 Mb/s (STi0-23) by half a master clock (C16i) cycle. This feature is useful in compensating for variable output delays caused by various output loading conditions. The frame output offset registers (FOR0 & FOR1) control the output offset delays for each backplane output stream via the OFn bit programming. Table 12 and Figure 10 detail frame output offset programming.

3.5 Serial Input Frame Alignment Evaluation

The MT90863 provides the frame evaluation inputs, FE_{i0} to FE_{i23}, to determine different data input delays with respect to the frame pulse F_{0i}. By using the frame evaluation input select bits (FE0 to FE4) of the frame alignment register (FAR), users can select one of the twenty-four frame evaluation inputs for the frame alignment measurement.

A measurement cycle is started by setting the start frame evaluation (SFE) bit low for at least one frame. Then the evaluation starts when the SFE bit in the Internal Mode Selection (IMS) register is changed from low to high. One frame later, the complete frame evaluation (CFE) bit of the frame alignment register changes from low to high to signal that a valid offset measurement is ready to be read from bits 0 to 9 of the FAR register. The SFE bit must be set to zero before a new measurement cycle is started.

Timing Signals	ST-BUS Mode	CT Bus Mode	HMVIP Mode
F _{0i} Width	61 ns	122 ns	244 ns
$\overline{C4i}/C8i$	Not Required	8.192 MHz	4.096 MHz
C _{16i}	16.384 MHz		
F _{0o} Width	244 ns		
C _{4o}	4.096 MHz		

Table 1 - Timing Signals Requirements for Various Operation Modes

DMS Register Bits			Modes	Backplane Interface	Data Rate
BMS2	BMS1	BMS0			
0	0	0	2 Mb/s, ST-BUS Mode	STio0 - 31	2.048 Mb/s
0	0	1	2 Mb/s, CT Bus Mode	STio0 - 31	2.048 Mb/s
0	1	0	4 Mb/s, ST-BUS Mode	STio0 - 31	4.096 Mb/s
0	1	1	4 Mb/s, CT Bus Mode	STio0 - 31	4.096 Mb/s
1	0	0	8 Mb/s, ST-BUS Mode	STio0 - 15	8.192 Mb/s
				STio16 - 31	Not available
1	0	1	8 Mb/s, CT Bus Mode	STio0 - 15	8.192 Mb/s
				STio16 - 31	Not available
1	1	0	HMVIP Mode	STio0 - 15	2.048 Mb/s
				STio16 - 23	8.192 Mb/s
				STio24 - 31	Not available

Table 2 - Mode Selection for Backplane interface

DMS Register Bits		Modes	Local Interface	Data Rate
LMS1	LMS0			
0	0	2 Mb/s Mode	STi0 - 15	2.048 Mb/s
			STo0 - 15	2.048 Mb/s
0	1	Sub-Rate Switching Mode	STi0 - 11	2.048 Mb/s
			STi12	Sub-rate Switching Input Stream at 2.048 Mb/s
			STi13 - 15	Not available
			STo0 - 11	2.048 Mb/s
			STo12	Sub-rate Switching Output Stream at 2.048 Mb/s
			STo13 - 15	Not available
1	0	8 Mb/s Mode	STi0 - 3	8.192 Mb/s
			STi4 - 15	Not available
			STo0 - 3	8.192 Mb/s
			STo4 - 15	Not available

Table 3 - Mode Selection for Local Interface

The falling edge of the frame measurement signal (FE_i) is evaluated against the falling edge of the frame pulse (FO_i). Table 8 and Figure 8 describe the frame alignment register.

3.6 Memory Block Programming

The MT90863 has two connection memories: the backplane connection memory and the local connection memory. The local connection memory is partitioned into high and low parts. The IMS register provides users with the capability of initializing the local connection memory low and the backplane connection memory in two frames. Bit 11 to bit 13 of every backplane connection memory location will be programmed with the pattern stored in bit 7 to bit 9 of the IMS register. Bit 12 to 15 of every local connection memory low location will be programmed with the pattern stored in bits 3 to 6 of the IMS register.

The block programming mode is enabled by setting the memory block program (MBP) bit of the control register high. When the block programming enable (BPE) bit of the IMS register is set to high, the block programming data will be loaded into bits 11 to 13 of every backplane connection memory and bits 12 to 15 of every local connection memory low. The other connection memory bits are loaded with zeros. When the memory block programming is complete, the device resets the BPE bit to zero. See Figure 7 for the connection memory contents when the device is in block programming mode.

4.0 Delay through the MT90863

The switching of information from the input serial streams to the output serial streams results in a throughput delay. The device can be programmed to perform time-slot interchange functions with different throughput delay capabilities on a per-channel basis. For voice applications, select variable throughput delay to ensure minimum delay between input and output data. In wideband data applications, select constant throughput delay to maintain the frame integrity of the information through the switch.

The delay through the device varies according to the type of throughput delay selected in the LV/C and BV/C bits of the local and backplane connection memory as described in Table 16 and Table 19.

4.1 Variable Delay Mode (\overline{LV}/C or \overline{BV}/C bit = 0)

The delay in this mode is dependent only on the combination of source and destination channels and is independent of input and output streams.

4.2 Constant Delay Mode (\overline{LV}/C bit or $\overline{BV}/C= 1$)

In this mode a multiple data memory buffer is used to maintain frame integrity in all switching configurations.

5.0 Microprocessor Interface

The MT90863 provides a parallel microprocessor interface for non-multiplexed bus structures. This interface is compatible with Motorola non-multiplexed buses. The required microprocessor signals are the 16-bit data bus (D0-D15), 8-bit address bus (A0-A7) and 4 control lines (CS, DS, R/W and DTA). See Figure 16 - Figure 16 for Motorola non-multiplexed bus timing.

The MT90863 microprocessor port provides access to the internal registers, connection and data memories. All locations provide read/write access except for the Data Memory and the Data Read Register which are read only.

5.1 Memory Mapping

The address bus on the microprocessor interface selects the internal registers and memories of the MT90863. If the A7 address input is low, then the registers are addressed by A6 to A0 as shown in Table 4.

If the A7 is high, the remaining address input lines are used to select the serial input or output data streams corresponding to the subsection of memory positions. For data memory reads, the serial inputs are selected. For connection memory writes, the serial outputs are selected.

The control, device mode selection and internal mode selection registers control all the major functions of the device. The device mode selection register and internal mode selection register should be programmed immediately after system power-up to establish the desired switching configuration as explained in the Frame Alignment Timing and Switching Configurations sections.

The control register is used to control the switching operations in the MT90863. It selects the internal memory locations that specify the input and output channels selected for switching.

Control register data consists of: the memory block programming bit (MBP); the memory select bits (MS0-2); and, the stream address bits (STA0-4). The memory block programming bit allows users to program the entire connection memory block, (see Memory Block Programming section). The memory select bits control the selection of the connection memory or the data memory. The stream address bits define an internal memory subsections corresponding to serial input or serial output streams.

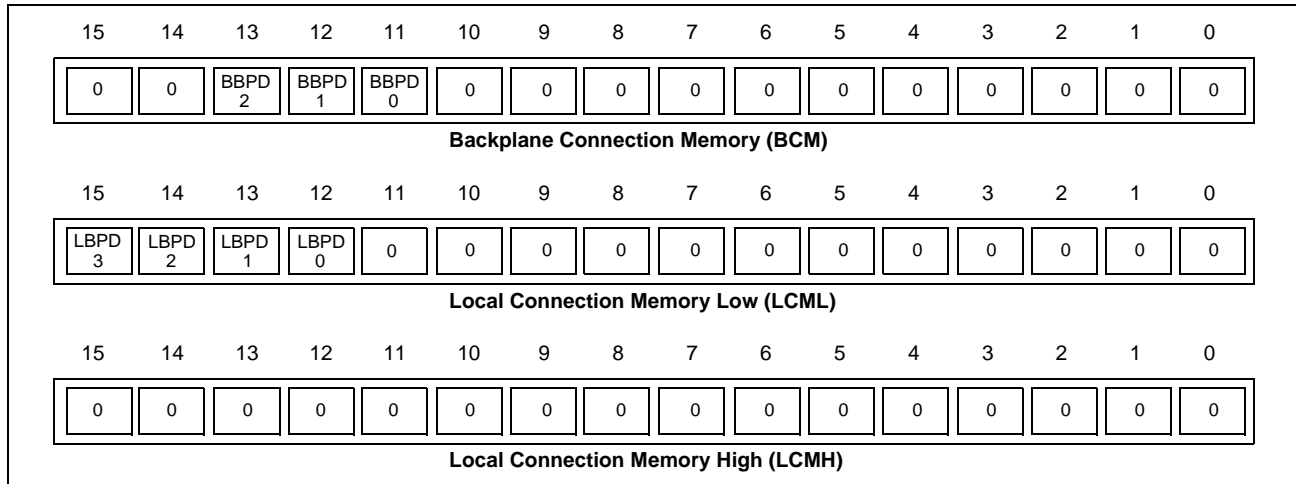

Figure 7 - Block Programming Data in the Connection Memories

A7 (Note 1)	A6	A5	A4	A3	A2	A1	A0	Location
0	0	0	0	0	0	0	0	Control Register, CR
0	0	0	0	0	0	0	1	Device Mode Selection Register, DMS
0	0	0	0	0	0	1	0	Internal Mode Selection Register, IMS
0	0	0	0	0	0	1	1	Frame Alignment Register, FAR
0	0	0	0	0	1	0	0	Input Offset Selection Register 0, DOS0
0	0	0	0	0	1	0	1	Input Offset Selection Register 1, DOS1
0	0	0	0	0	1	1	0	Input Offset Selection Register 2, DOS2
0	0	0	0	0	1	1	1	Input Offset Selection Register 3, DOS3
0	0	0	0	1	0	0	0	Input Offset Selection Register 4, DOS4
0	0	0	0	1	0	0	1	Input Offset Selection Register 5, DOS5
0	0	0	0	1	0	1	0	Frame Output Offset Register, FOR0
0	0	0	0	1	0	1	1	Frame Output Offset Register, FOR1
0	0	0	0	1	1	0	0	Address Buffer Register, ABR
0	0	0	0	1	1	0	1	Data Write Register, DWR
0	0	0	0	1	1	1	0	Data Read Register, DRR
1	0	0	0	0	0	0	0	Ch 0
1	0	0	0	0	0	0	1	Ch 1
1	0	0
1	0	0	1	1	1	1	0	Ch 30
1	0	0	1	1	1	1	1	Ch 31

Table 4 - Address Memory Map

A7 (Note 1)	A6	A5	A4	A3	A2	A1	A0	Location
1	0	1	0	0	0	0	0	Ch 32
1	0	1	0	0	0	0	1	Ch 33
.
1	1	1	1	1	1	1	0	Ch 126
1	1	1	1	1	1	1	1	Ch 127

(Note 3)

Notes:
1. Bit A7 must be high for access to data and connection memory positions. Bit A7 must be low for access to registers.
2. Channels 0 to 31 are used when serial stream is at 2 Mb/s.
3. Channels 0 to 127 are used when serial stream is at 8 Mb/s

Table 4 - Address Memory Map (continued)

The data in the DMS register consists of the local and backplane mode selection bits (LMS0-1 and BMS0-2) to enable various switching modes for local and backplane interfaces respectively.

The data in the IMS register consists of block programming bits (LBPD0-3 and BBPD0-2), block programming enable bit (BPE), output standby bit (OSB) and start frame evaluation bit (SFE). The block programming enable bit allows users to program the entire backplane and local connection memories, (see Memory Block Programming section). If the ODE pin is low, the OSB bit enables (if high) or disables (if low) all ST-BUS output drivers. If the ODE pin is high, the contents of the OSB bit is ignored and all ST-BUS output drivers are enabled.

See Table 5 for the output high impedance control.

5.2 Address Buffer Mode

The implementation of the address buffer, data read and data write registers allows faster memory read/write operation for the microprocessor port. See Table 6 and following for bit assignments.

The address buffer mode is controlled by the AB bit in the control register. The targeted memory for data read/write is selected by the MS0-2 bits in the control register.

The data write register (DWR) contains the data to be transferred to the memory. The data read register (DRR) contains the data transferred from the memory.

The address buffer register (ABR) allow users to specify the read or write address by programming the stream address bits (SA0-4) and the channel address bits (CA0-6). Data transfer from/to the memory is controlled by the read/write select bits (RS, WS). The complete data access (CDA) bit indicates the completion of data transfer between the memory and DWR or DRR register.

5.3 Write Operation using Address Buffer Mode

Enable the address buffer mode by setting the AB bit from low to high. Program the DWR register with data to be transferred to memory. Load the ABR register with proper channel and stream information. Change the WS bit in the ABR register from low to high to initiate the data transfer from the DWR register to the memory. After several master clock cycles, the CDA bit in the ABR register changes from low to high to signal the completion of data transfer and resets the WS bit to low. Repeat the above steps for subsequent memory write operations. Disable the address buffer write operation by setting the AB bit to low.

5.4 Read Operation using Address Buffer Mode

Enable the address buffer mode by setting the AB bit from low to high. Program the ABR register with proper channel and stream information. Change the RS bit in the ABR register from low to high to initiate the data transfer from the memory to the DRR register. After several master clock cycles, the CDA bit in the ABR register changes

from low to high to signal the completion of data transfer and resets the RS bit to low. Read the DRR register to obtain the data transferred from the memory. Repeat the above steps for subsequent memory read operations. Disable the address buffer read operation by setting the AB bit to low.

5.5 Backplane Connection Memory Control

The backplane connection memory controls the switching configuration of the backplane interface. Locations in the backplane connection memory are associated with particular STio output streams.

The \overline{B}/C (Variable/Constant Delay) bit of each backplane connection memory location allows the per-channel selection between variable and constant throughput delay modes for all STio channels.

In message mode, the message channel (BMC) bit of the backplane connection memory enables (if high) an associated STio output channel. If the BMC bit is low, the contents of the backplane connection memory stream address bit (BSAB) and channel address bit (BCAB) defines the source information (stream and channel) of the time-slot that will be switched to the STio streams. When message mode is enabled, only the lower half (8 least significant bits) of the backplane connection memory is transferred to the STio pins.

ODE pin	OSB bit in IMS register	DC bit in Backplane CM	STio0-31 Output Driver Status	OE bit in Local CM	STo0-15 Output Driver Status
Don't Care	Don't Care	0	Per Channel High Impedance	0	Per Channel High Impedance
0	0	Don't care	High Impedance	Don't care	High Impedance
0	1	1	Enable	1	Enable
1	Don't care	1	Enable	1	Enable

Table 5 - Output High Impedance Control

Read/Write Address: 00 _H , Reset Value: 0000 _H .															
15	14	13	12	11	10	9	8	7	6	5	4	3	2	1	0
0	0	0	0	0	AB	CT	MBP	MS2	MS1	MS0	STA4	STA3	STA2	STA1	STA0
Bit	Name	Description													
15-11	Unused	Must be zero for normal operation.													
10	AB	Address Buffer. When 1, enables the address buffer, data write and data read registers for accessing various memory locations for fast microport access. When 0, disables the address buffer, data write and data read registers.													
9	CT	Channel Tri-state. When 1, the last bit of each output channel is tri-stated for -22 ns against the channel boundary. When 0, the last bit of each channel is not tri-stated.													
8	MBP	Memory Block Program. When 1, the connection memory block programming feature is ready for the programming of bit 11 to 13 for backplane connection memory, bit 12 to 15 for local connection memory low. When 0, this feature is disabled.													

Table 6 - Control (CR) Register Bits

Read/Write Address: 00 _H , Reset Value: 0000 _H .															
15	14	13	12	11	10	9	8	7	6	5	4	3	2	1	0
0	0	0	0	0	AB	CT	MBP	MS2	MS1	MS0	STA4	STA3	STA2	STA1	STA0
Bit	Name	Description													
7 - 5	MS2-0	Memory Select Bits. These three bits are used to select connection and data memory functions as follows: <u>MS2-0</u> <u>Memory Selection</u> 000 Local Connection Memory Low Read/Write, 001 Local Connection Memory High Read/Write, 010 Backplane Connection Memory Read/Write, 011 Local Data Memory Read, 100 Backplane Data Memory Read,													
4 - 0	STA4-0	Stream Address Bits. The binary value expressed by these bits refers to the input or output data stream, which corresponds to the subsection of memory made accessible for subsequent operations. (STA4 = MSB, STA0 = LSB)													

Table 6 - Control (CR) Register Bits

Read/Write Address: 01 _H , Reset Value: 0000 _H .															
15	14	13	12	11	10	9	8	7	6	5	4	3	2	1	0
0	0	0	0	0	0	0	0	0	0	0	LMS1	LMS0	BMS2	BMS1	BMS0
Bit	Name	Description													
15 - 5	unused	Reserved													
4 - 3	LMS	Local Mode Selection Bit. The binary value expressed by these bits refers to the following backplane interface switching modes: <u>LMS1-0</u> <u>Local Switching Mode</u> 00 2 Mb/s ST-BUS Mode 01 2 Mb/s Sub-rate Switching Mode 10 8 Mb/s ST-Bus Mode													
2 - 0	BMS2-0	Backplane Mode Selection Bits. The binary value expressed by these bits refers to the following backplane interface switching modes: <u>BMS2-0</u> <u>Backplane Switching Mode</u> 000 2 Mb/s ST-BUS Mode 001 2 Mb/s CT Bus Mode 010 4 Mb/s ST-BUS Mode 011 4 Mb/s CT Bus Mode 100 8 Mb/s ST-BUS Mode 101 8 Mb/s CT Bus Mode 110 HMOVIP Mode													
Note: Please refer to Table 1 for Timing Signal Requirements															

Table 7 - Device Mode Selection (DMS) Register Bits

5.6 Local Connection Memory Control

The local connection memory controls the local interface switching configuration. Local connection memory is split into high and low parts. Locations in local connection memory are associated with particular STo output streams.

The L/B (Local/Backplane Select) bit of each local connection memory location allows per-channel selection of source streams from local or backplane interface.

The $\overline{LV/C}$ (Variable/Constant Delay) bit of each local connection memory location allows the per-channel selection between variable and constant throughput delay modes for all STo channels.

In message mode, the local connection memory message channel (LMC) bit enables (if high) an associated STo output channel. If the LMC bit is low, the contents of the stream address bit (LSAB) and the channel address bit (LCAB) of the local connection memory defines the source information (stream and channel) of the time-slot that will be switched to the STo streams. When message mode is enabled, only the lower half (8 least significant bits) of the local connection memory low bits are transferred to the STo pins.

When sub-rate switching is enabled, the LSR0-1 bits in the local connection memory high define which bit position contains the sub-rate data.

5.7 \overline{DTA} Data Transfer Acknowledgment Pin

The \overline{DTA} pin is driven LOW by internal logic to indicate (to the CPU) that a data bus transfer is complete. When the bus cycle ends, this pin drives HIGH and then switches to the high-impedance state. If a short or signal contention prevents the \overline{DTA} pin from reaching a valid logic HIGH, it will continue to drive for approximately 15nsec before switching to the high-impedance state.

6.0 Initialization of the MT90863

During power up, the \overline{TRST} pin should be pulsed low, or held low continuously, to ensure that the MT90863 is in the normal operation mode. A 5 K Ω pull-down resistor can be connected to this pin so that the device will not enter the JTAG test mode during power up.

After power up, the contents of the connection memory can be in any state. The ODE pin should be held low after power up to keep all serial outputs in a high impedance state until the microprocessor has initialized the switching matrix. This procedure prevents two serial outputs from driving the same stream simultaneously.

During the microprocessor initialization routine, the microprocessor should program the desired active paths through the switch. The memory block programming feature can also be used to quickly initialize the DC and OE bit in the backplane and local connection memory respectively.

When this process is complete, the microprocessor controlling the matrices can either bring the ODE pin high or enable the OSB bit in IMS register to relinquish the high impedance state control.

Read/Write Address: 02 _H ,																						
Reset Value: 0000 _H .																						
15	14	13	12	11	10	9	8	7	6	5	4	3	2	1	0							
0	0	0	0	0	0	BBPD 2	BBPD 1	BBPD 0	LBDP 3	LBDP 2	LBDP 1	LBDP 0	BPE	OSB	SFE							
Bit	Name	Description																				
15-10	Unused	Must be zero for normal operation.																				
9-7	BBPD2-0	Backplane Block Programming Data. These bits carry the value to be loaded into the backplane connection memory block when the Memory Block Programming feature is active. After the MBP bit in the control register is set to 1 and the BPE bit is set to 1, the contents of bits BBPD2-0 are loaded into the bit 13 to bit 11 position of the backplane connection memory. Bit 15, bit 14 and bit 10 to bit 0 of the backplane connection memory are zeroed.																				
6-3	LBDP3-0	Local Block Programming Data. These bits carry the value to be loaded into the local connection memory block when the Memory Block Programming feature is active. After the MBP bit in the control register is set to 1 and the BPE bit is set to 1, the contents of bits LBDP3-0 are loaded into the bit 15 to bit 12 position of the local connection memory. Bit 11 to bit 0 of the local connection memory low are zeroed. Bit 15 to bit 0 of local connection memory high are zeroed.																				
2	BPE	Begin Block Programming Enable. A zero to one transition of this bit enables the memory block programming function. The BPE, BBPD2-0 and LBDP3-0 bits in the IMS register must be defined in the same write operation. Once the BPE bit is set high, the device requires two frames to complete the block programming. After the programming function has finished, the BPE bit returns to zero to indicate the operation is completed. When the BPE = 1, the BPE or MBP can be set to 0 to abort the programming operation. When BPE = 1, the other bits in the IMS register must not be changed for two frames to ensure proper operation.																				
1	OSB	Output Stand By. This bit controls the device output drivers. <table border="1"> <thead> <tr> <th>OSB bit</th><th>ODE pin</th><th>OE bit</th><th>STi0 - 31, STo0 - 15</th></tr> </thead> <tbody> <tr> <td>0</td><td>0</td><td>1</td><td>High impedance state</td></tr> <tr> <td>1</td><td>0</td><td>1</td><td>Enable</td></tr> <tr> <td>X</td><td>1</td><td>1</td><td>Enable</td></tr> <tr> <td>X</td><td>X</td><td>0</td><td>Per-channel high impedance</td></tr> </tbody> </table>	OSB bit	ODE pin	OE bit	STi0 - 31, STo0 - 15	0	0	1	High impedance state	1	0	1	Enable	X	1	1	Enable	X	X	0	Per-channel high impedance
OSB bit	ODE pin	OE bit	STi0 - 31, STo0 - 15																			
0	0	1	High impedance state																			
1	0	1	Enable																			
X	1	1	Enable																			
X	X	0	Per-channel high impedance																			
0	SFE	Start Frame Evaluation. A zero to one transition in this bit starts the frame evaluation procedure. When the CFE bit in the FAR register changes from zero to one, the evaluation procedure stops. Set this bit to zero for at least one frame (125 μs) to start another frame evaluation.																				

Table 8 - Internal Mode Selection (IMS) Register Bits

Read/Write Address: 03 _H ,															
Reset Value: 0000 _H .															
15	14	13	12	11	10	9	8	7	6	5	4	3	2	1	0
FE4	FE3	FE2	FE1	FE0	CFE	FD9	FD8	FD7	FD6	FD5	FD4	FD3	FD2	FD1	FD0

Bit	Name	Description
15-11	FE4-0	Frame Evaluation Input Select. The binary value expressed in these bits refers to the frame evaluation inputs, FE _i 0 to FE _i 23.
10	CFE	Complete Frame Evaluation. When CFE = 1, the frame evaluation is completed and bits FD9 to FD0 bits contains a valid frame alignment offset. This bit is reset to zero, when SFE bit in the IMS register is changed from 1 to 0. This bit is read-only.
9	FD9	Frame Delay Bit 11. The falling edge of FE is sampled during the CLK-high phase (FD9 = 1) or during the CLK-low phase (FD9 = 0). This bit allows the measurement resolution to 1/2 CLK cycle. This bit is read-only.
8-0	FD8-0	Frame Delay Bits. The binary value expressed in these bits refers to the measured input offset value. These bits are reset to zero when the SFE bit of the IMS register changes from 1 to 0. (FD8 = MSB, FD0 = LSB). These bits are also read-only

Table 9 - Frame Alignment (FAR) Register Bit

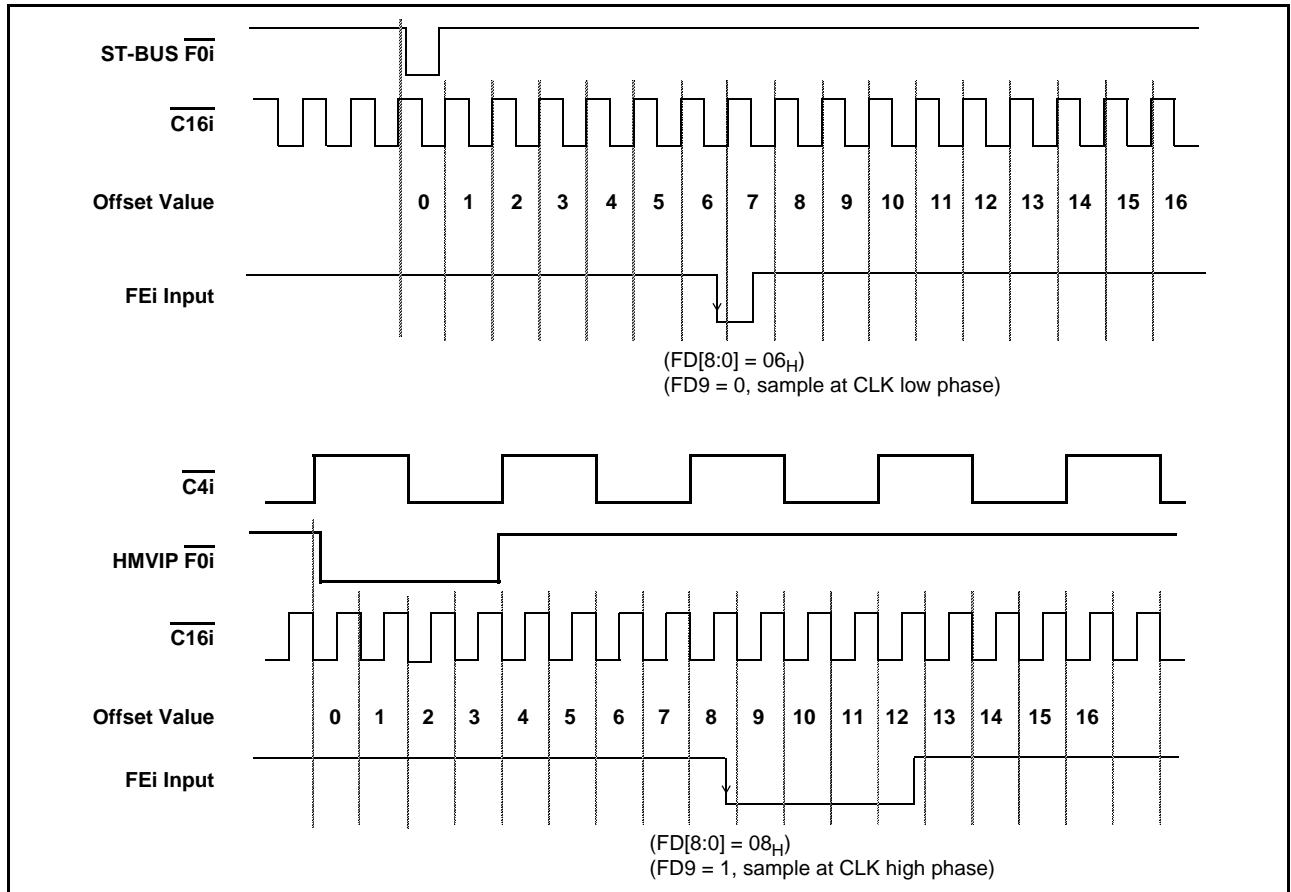
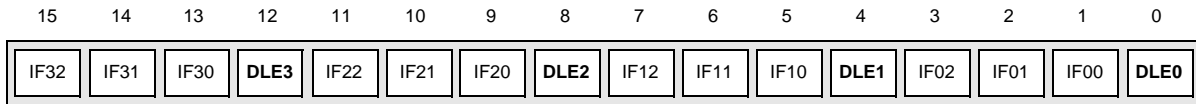

Figure 8 - Example for Frame Alignment Measurement

Read/Write Address: 04_H for DOS0 register,
 05_H for DOS1 register,
 06_H for DOS2 register,
 07_H for DOS3 register,
 08_H for DOS4 register,
 09_H for DOS5 register,

Reset value: 0000_H for all DOS registers.



DOS0 register

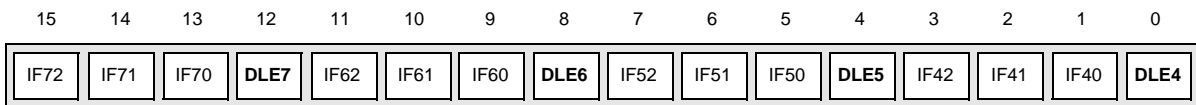

DOS1 register

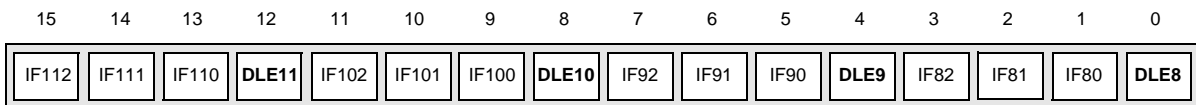

DOS2 register

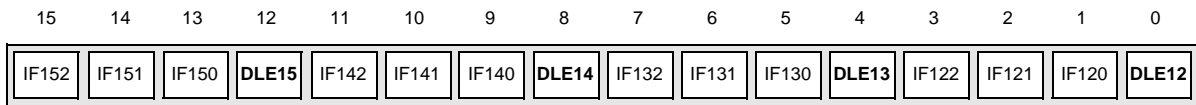

DOS3 register

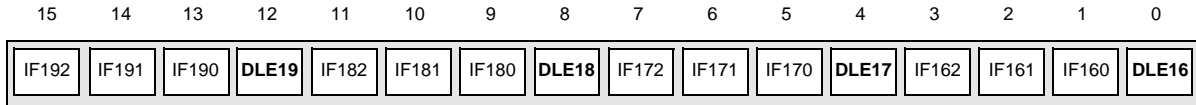

DOS4 register

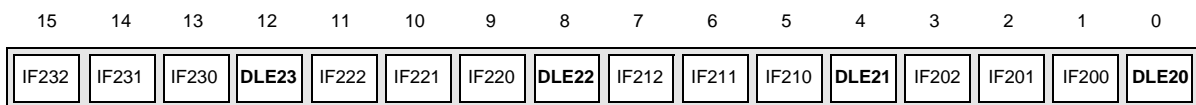

DOS5 register

Name (Note 1)	Description
IFn2, IFn1, IFn0	Input Offset Bits 2,1 & 0. These three bits define how long the serial interface receiver takes to recognize and store bit 0 from the STio pin: i.e., to start a new frame. The input frame offset can be selected to +4 clock periods from the point where the external frame pulse input signal is applied to the FOi inputs of the device. Figure 9 -
DLEn	Data Latch Edge. ST-BUS mode: DLEn =0, if clock rising edge is at the 3/4 point of the bit cell. DLEn =1, if clock falling edge is at the 3/4 point of the bit cell.

Table 10 - Frame Delay Offset (DOS) Register Bits

Read/Write Address: 04_H for DOS0 register,
 05_H for DOS1 register,
 06_H for DOS2 register,
 07_H for DOS3 register,
 08_H for DOS4 register,
 09_H for DOS5 register,

Reset value: 0000_H for all DOS registers.

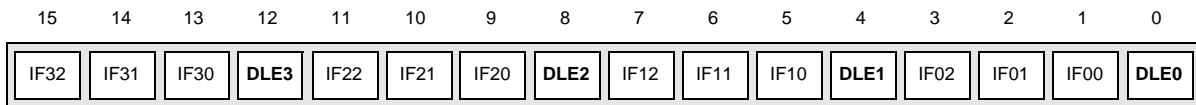

DOS0 register

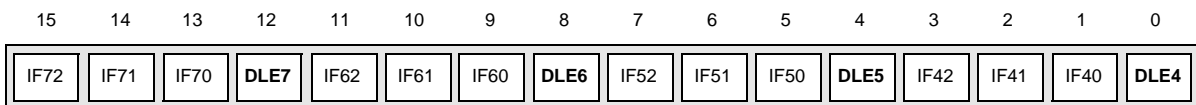

DOS1 register

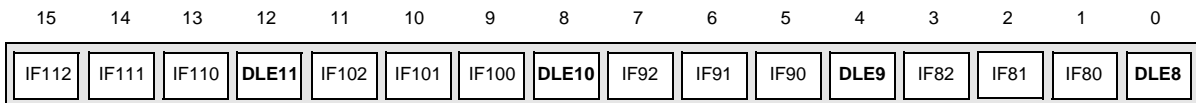

DOS2 register

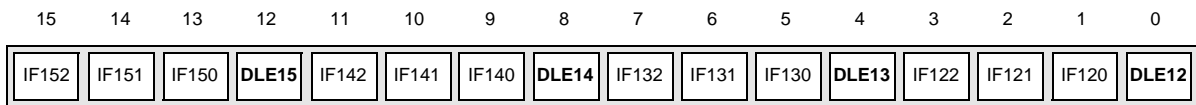

DOS3 register

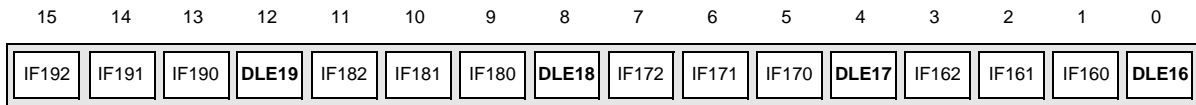

DOS4 register

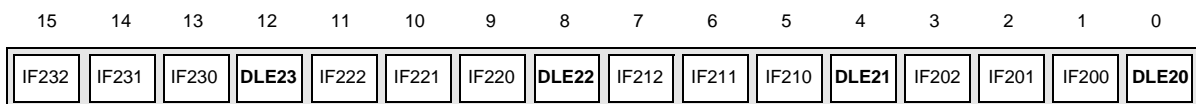

DOS5 register

Name (Note 1)	Description
------------------	-------------

Note 1: n denotes a STiO stream number from 0 to 23.

Table 10 - Frame Delay Offset (DOS) Register Bits

Input Stream Offset	Measurement Result from Frame Delay Bits				Corresponding Offset Bits			
	FD9	FD2	FD1	FD0	IFn2	IFn1	IFn0	DLEn
No clock period shift (Default)	1	0	0	0	0	0	0	0
+ 0.5 clock period shift	0	0	0	0	0	0	0	1
+1.0 clock period shift	1	0	0	1	0	0	1	0
+1.5 clock period shift	0	0	0	1	0	0	1	1
+2.0 clock period shift	1	0	1	0	0	1	0	0
+2.5 clock period shift	0	0	1	0	0	1	0	1
+3.0 clock period shift	1	0	1	1	0	1	1	0
+3.5 clock period shift	0	0	1	1	0	1	1	1
+4.0 clock period shift	1	1	0	0	1	0	0	0
+4.5 clock period shift	0	1	0	0	1	0	0	1

Table 11 - Offset Bits (IFn2, IFn1, IFn0, DLEn) & Input Offset Bits (FD9, FD2-0)

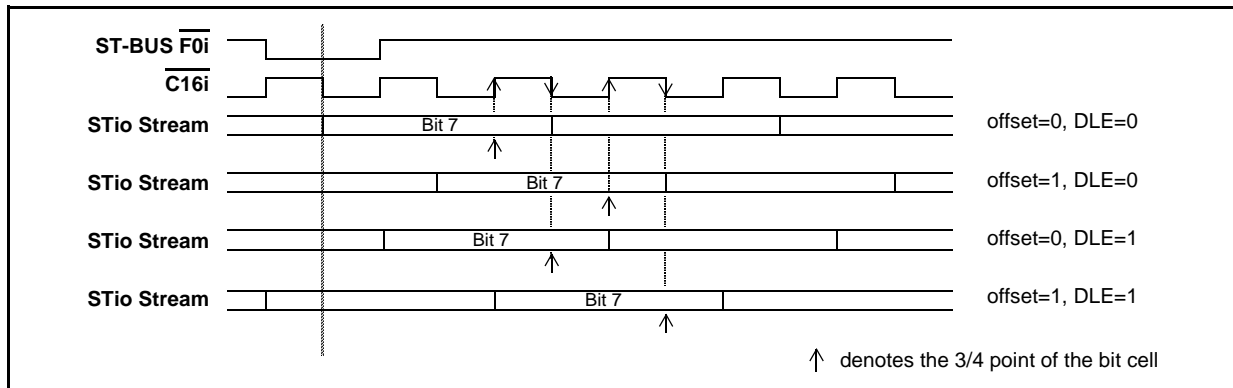
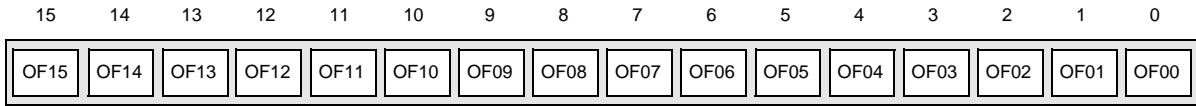
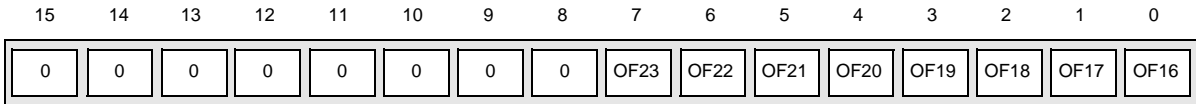

Figure 9 - Examples for Input Offset Delay Timing

Read/Write Address: 0A_H for FOR0 register,
 0B_H for FOR1 register,
 Reset value: 0000_H for all FOR registers.



FOR0 register



FOR1 register

Bit	Name (Note 1)	Description
15-0 (FOR0) 7-0 (FOR1)	OF _n	Output Offset Bit. When 0, the first bit of the serial output stream has normal alignment with the frame pulse. When 1, the first bit of the serial output stream is advanced by 1/2 CLK cycle with respect to the frame pulse. See Figure 10.
15-8 (FOR1)	Unused	Must be zero for normal operation.

Note 1: n denotes a STio stream number from 0 to 23

Table 12 - Frame Output Offset (FOR) Register Bits

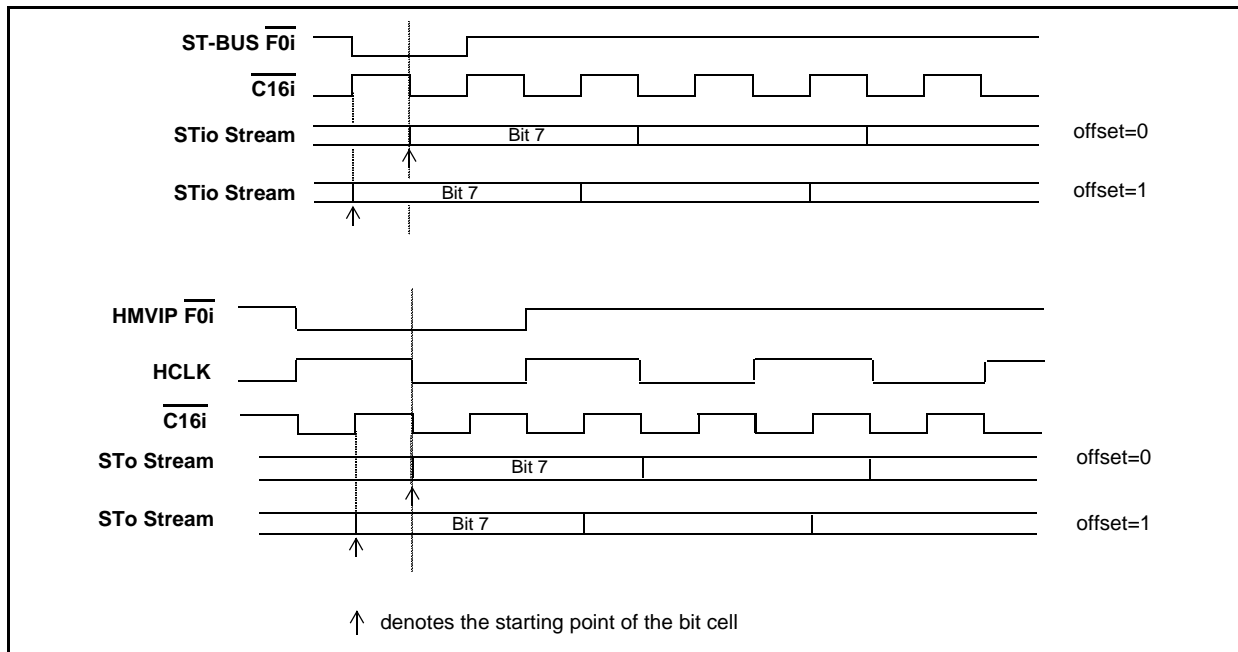

Figure 10 - Examples for Frame Output Offset Timing

Read/Write Address: 0C _H for ABR register,															
Reset value: 0000 _H															
15	14	13	12	11	10	9	8	7	6	5	4	3	2	1	0
0	CDA	RS	WS	CA6	CA5	CA4	CA3	CA2	CA1	CA0	SA4	SA3	SA2	SA1	SA0
Bit	Name	Description													
15	unused	Reserved													
14	CDA	Complete Data Access. This bit is read only. This bit changes from 0 to 1 when data transfer is completed between memory and the data read register or data write register. When the RS or WS bit in this register is changed from 1 to 0, this bit is reset to zero.													
13	RS	Read Select. A zero to one transition of this bit initiates the data transfer from memory to the data read register. This bit is reset to zero when the CDA bit changes from 0 to 1.													
12	WS	Write Select. A zero to one transition of this bit initiates the data transfer from the data write register to memory. This bit is reset to zero when the CDA bit changes from 0 to 1.													
11 - 5	CA6 - CA0	Channel Address Bits. These bits perform the same function as the external address bits when used to access various memory locations. The number (expressed in binary notation) on these bits refers to the input or output data stream channel that corresponds to the subsection of memory.													
4 - 0	SA4 - SA0	Stream Address Bits. These bits perform the same function as the STA bits in the control register. The number (in binary notation) on these bits refers to the input or output data stream which corresponds to the subsection of memory.													

Table 13 - Address Buffer (ABR) Register Bits

Read/Write Address: 0D _H for DWR register,															
Reset value: 0000 _H															
15	14	13	12	11	10	9	8	7	6	5	4	3	2	1	0
WR15	WR14	WR13	WR12	WR11	WR10	WR9	WR8	WR7	WR6	WR5	WR4	WR3	WR2	WR1	WR0
Bit	Name	Description													
15 - 0	WR15 - WR0	Write Data Bits. Data to be transferred to the internal memory locations.													

Table 14 - Data Write (DWR) Register Bits

Read Address:	0E _H for DRR register,	
Reset value:	0000 _H	
	15 14 13 12 11 10 9 8 7 6 5 4 3 2 1 0	
	RD15 RD14 RD13 RD12 RD11 RD10 RD9 RD8 RD7 RD6 RD5 RD4 RD3 RD2 RD1 RD0	
Bit	Name	Description
15 - 0	RD15 - RD0	Read Data Bits. Data transferred from one of the internal memory locations.

Table 15 - Data Read (DRR) Register Bits

	15 14 13 12 11 10 9 8 7 6 5 4 3 2 1 0	
	0 0 BV/C BMC DC BSAB ₃ BSAB ₂ BSAB ₁ BSAB ₀ BCAB ₆ BCAB ₅ BCAB ₄ BCAB ₃ BCAB ₂ BCAB ₁ BCAB ₀	
Bit	Name	Description
15,14	Unused	Must be zero for normal operation.
13	BV/C	Variable /Constant Throughput Delay. This bit is used to select either variable (low) or constant delay (high) modes on a per-channel basis for the local interface streams.
12	BMC	Message Channel. When 1, the backplane connection memory contents are output on the corresponding output channel and stream. Only the lower byte (bit 7 - bit 0) will be output to the backplane interface STio pins. When 0, the local data memory address of the switched STi input channel and stream is loaded into the backplane connection memory.
11	DC	Directional Control. This bit enables the STio pindrivers on a per-channel basis. When 1, the STio output driver functions normally. When 0, the STio output driver is in a high-impedance state.
10-7 (Note 1)	BSAB3-0	Source Stream Address Bits. The binary value is the number of the data stream for the source of the connection.
6-0 (Note 1)	BCAB6-0	Source Channel Address Bits. The binary value identifies the channel for the connection source.
<p>Note 1: If bit 12 (BMC) of the corresponding backplane connection memory location is 1 (device in message mode), then these entire 8 bits (BSAB0, BCAB6 - BCAB0) are output on the output channel and stream associated with this location.</p>		

Table 16 - Blackplane Connection Memory Bits

Data Rate	BSAB3 to BSAB0 Bits Used to Determine the Source Stream of the connection
2.048 Mb/s	STi0 to STi15
8.192 Mb/s	STi0 to STi3
2.048 Mb/s Sub-rate Switching	STi0 to STi12

Table 17 - BSAB Bits Programming for Different Local Interface mode

Data Rate	BCAB Bits Used to Determine the Source Channel of the Connection
2.048 Mb/s	BCAB4 to BCAB0 (32 channel/frame)
8.192 Mb/s	BCAB6 to BCAB0 (128 channel/frame)
2.048 Mb/s Sub-rate Switching	BCAB4 to BCAB0 (32 channel/frame) BCAB6 to BCAB0 (128 channel/frame)

Table 18 - BCAB Bits Programming for Different Data Rates

15	14	13	12	11	10	9	8	7	6	5	4	3	2	1	0
L/B	BV/C	BMC	OE	LSAB ₄	LSAB ₃	LSAB ₂	LSAB ₁	LSAB ₀	LCAB ₆	LCAB ₅	LCAB ₄	LCAB ₃	LCAB ₂	LCAB ₁	LCAB ₀
Bit	Name	Description													
15	L/B	Local/Backplane Select When 1, the output channel of STo0-15 comes from STi0-15 (local) When 0, the output channel of STo0-15 comes from: STi0-31 (backplane, 2 Mb/s mode) STi0-31 (backplane, 4 Mb/s mode) STi0-15 (blackplane, 8 Mb/s mode) STi0-23 (blackplane, HMVIP mode)													
14	L \bar{V} /C	Variable /Constant Throughput Delay. This bit is used to select either variable (low) or constant delay (high) modes on a per-channel basis for the source streams.													
13	LMC	Message Channel. When 1, the contents of the local connection memory are output on the corresponding output channel and stream. Only the lower byte (bit 7 - bit 0) will be output to the STo pins of the local interface. When 0, the backplane or local data memory address of the switched input channel and stream is loaded into the local connection memory.													
12	OE	Output Enable. This bit enables the drivers of STo pins on a per-channel basis. When 1, the STo output driver functions normally. When 0, the STo output driver is in a high-impedance state.													

Table 19 - Local Connection Memory Low Bits

15	14	13	12	11	10	9	8	7	6	5	4	3	2	1	0
L/B	BV/C	BMC	OE	LSAB 4	LSAB 3	LSAB 2	LSAB 1	LSAB 0	LCAB 6	LCAB 5	LCAB 4	LCAB 3	LCAB 2	LCAB 1	LCAB 0
Bit	Name	Description													
11-7 (Note 1)	LSAB4-0	Source Stream Address Bits. The binary value identifies the data stream for the source of the connection.													
6-0 (Note 1)	LCAB6-0	Source Channel Address Bits. The binary value identifies the channel for the source of the connection.													
<p>Note 1: If bit 12 (LMC) of the corresponding local connection memory location is 1 (device in message mode), then these entire 8 bits (LSAB0, LCAB6 - LCAB0) are output on the output channel and stream associated with this location.</p>															

Table 19 - Local Connection Memory Low Bits (continued)

Data Rate	LSAB3 to LSAB0 Bits Used to Determine the Source Stream of the Connection
2.048 Mb/s	STio0 to STio31 or STi0 to STi15
4.096 Mb/s	STio0 to STio31
8.192 Mb/s	STio0 to STio15 or STi0 to STi3
HMVIP	STio0 to STio23
2.048 Mb/s Sub-rate Switching	STi0 to STi12

Table 20 - LSAB Bits Programming for Different Local Interface Modes

Data Rate	LCAB Bits Used to Determine the Source Channel of the Connection
2.048 Mb/s	LCAB4 to LCAB0 (32 channel/frame)
4.096 Mb/s	LCAB5 to LCAB0 (64 channel/frame)
8.192 Mb/s	LCAB6 to LCAB0 (128 channel/frame)
HMVIP	LCAB4 to LCAB0 (32 channel/frame) LCAB6 to LCAB0 (128 channel/frame)
2.048 Mb/s Sub-rate Switching	LCAB4 to LCAB0 (32 channel/frame) LCAB6 to LCAB0 (128 channel/frame)

Table 21 - LCAB Bits Programming for Different Data Rates

15	14	13	12	11	10	9	8	7	6	5	4	3	2	1	0
0	0	0	0	0	0	0	0	0	0	0	0	0	0	LSR1	LSR0
Bit	Name	Description													
15-2 (Note1)	Unused	Must be zero for normal operation.													
1,0 (Note1)	LSR1, LSR0	Local Sub-rate Switching Bit When 11 Bit7-6 will be the output of the subrate switching stream When 10 Bit5-4 will be the output of the subrate switching stream When 01 Bit3-2 will be the output of the subrate switching stream When 00 Bit1-0 will be the output of the subrate switching stream													
Note 1: If bit 12 (LMC) of the corresponding local connection memory location is 1 (device in message mode), then these entire 8 bits (Bit7-0) are output on the output channel and stream associated with this location.															

Table 22 - Local Connection Memory High Bits

7.0 JTAG Support

The MT90863 JTAG interface conforms to the Boundary-Scan IEEE1149.1 standard. This standard specifies a design-for-testability technique called Boundary-Scan Test (BST). The operation of the boundary-scan circuitry is controlled by an external Test Access Port (TAP) Controller.

7.1 Test Access Port (TAP)

The Test Access Port (TAP) accesses the MT90863 test functions. It consists of three input pins and one output pin as follows:

- Test Clock Input (TCK)**
 TCK provides the clock for the test logic. The TCK does not interfere with any on-chip clock and thus remains independent. The TCK permits shifting of test data into or out of the Boundary-Scan register cells concurrently with the operation of the device and without interfering with the on-chip logic.
- Test Mode Select Input (TMS)**
 The TAP Controller uses the logic signals received at the TMS input to control test operations. The TMS signals are sampled at the rising edge of the TCK pulse. This pin is internally pulled to Vdd when it is not driven from an external source.
- Test Data Input (TDi)**
 Serial input data applied to this port is fed either into the instruction register or into a test data register, depending on the sequence previously applied to the TMS input. Both registers are described in a subsequent section. The received input data is sampled at the rising edge of TCK pulses. This pin is internally pulled to Vdd when it is not driven from an external source.
- Test Data Output (TDo)**
 Depending on the sequence previously applied to the TMS input, the contents of either the instruction register or data register are serially shifted out towards the TDo. The data out of the TDo is clocked on the falling edge of the TCK pulses. When no data is shifted through the boundary scan cells, the TDo driver is set to a high impedance state.
- Test Reset ($\overline{\text{TRST}}$)**
 Reset the JTAG scan structure. This pin is internally pulled to VDD.

Device Pin	Boundary Scan Bit 0 to Bit 213		
	Tri-state Control	Output Scan Cell	Input Scan Cell
D0	11	12	13
D1	14	15	16
D2	17	18	19
D3	20	21	22
D4	23	24	25
D5	26	27	28
D6	29	30	31
D7	32	33	34
D8	35	36	37
D9	38	39	40
D10	41	42	43
D11	44	45	46
D12	47	48	49
D13	50	51	52
D14	53	54	55
D15	56	57	58
\overline{DTA}		59	
STi0			60
STi1			61
STi2			62
STi3			63
STi4			64
STi5			65
STi6			66
STi7			67
STi8			68
STi9			69
STi10			70
STi11			71
STi12			72
STi13			73
STi14			74
STi15			75
ODE			76
STo0	77	78	
STo1	79	80	
STo2	81	82	
STo3	83	84	
STo4	85	86	
STo5	87	88	
STo6	89	90	
STo7	91	92	
STo8	93	94	
STo9	95	96	
STo10	97	98	
STo11	99	100	
STo12	101	102	
STo13	103	104	
STo14	105	106	
STo15	107	108	
$\overline{C16i}$			109
$\overline{F0i}$			110
$\overline{C4i/C8i}$			111
$\overline{F0o}$	112	113	
C4o	114	115	

Table 23 - Boundary Scan Register Bits (continued)

Device Pin	Boundary Scan Bit 0 to Bit 213		
	Tri-state Control	Output Scan Cell	Input Scan Cell
STio0/FE0	116	117	118
STio1/FE1	119	120	121
STio2/FE2	122	123	124
STio3/FE3	125	126	127
STio4/FE4	128	129	130
STio5/FE5	131	132	133
STio6/FE6	134	135	136
STio7/FE7	137	138	139
STio8/FE8	140	141	142
STio9/FE9	143	144	145
STio10/FE10	146	147	148
STio11/FE11	149	150	151
STio12/FE12	152	153	154
STio13/FE13	155	156	157
STio14/FE14	158	159	160
STio15/FE15	161	162	163
STio16/FE16	164	165	166
STio17/FE17	167	168	169
STio18/FE18	170	171	172
STio19/FE19	173	174	175
STio20/FE20	176	177	178
STio21/FE21	179	180	181
STio22/FE22	182	183	184
STio23/FE23	185	186	187
STio24	188	189	190
STio25	191	192	193
STio26	194	195	196
STio27	197	198	199
STio28	200	201	202
STio29	203	204	205
STio30	206	207	208
STio31	209	210	211
RESET			212

Table 23 - Boundary Scan Register Bits (continued)

Absolute Maximum Ratings*

	Parameter	Symbol	Min.	Max.	Units
1	Supply Voltage	V_{DD}	-0.5	5.0	V
2	Input Voltage	V_I	-0.5	$V_{DD} + 0.5$	V
3	Output Voltage	V_O	-0.5	$V_{DD} + 0.5$	V
4	Package power dissipation	P_D		2	W
5	Storage temperature	T_S	- 55	+125	°C

* Exceeding these values may cause permanent damage. Functional operation under these conditions is not implied.

Recommended Operating Conditions - Voltages are with respect to ground (V_{SS}) unless otherwise stated.

	Characteristics	Sym.	Min.	Typ.	Max.	Units	Test Conditions
1	Operating Temperature	T_{OP}	-40		+85	°C	
2	Positive Supply	V_{DD}	3.0		3.6	V	
3	Input High Voltage	V_{IH}	$0.7V_{DD}$		V_{DD}	V	
4	Input High Voltage on 5V Tolerant Inputs	V_{IH}			5.5	V	
5	Input Low Voltage	V_{IL}	V_{SS}		$0.3V_{DD}$	V	

AC Electrical Characteristics - Voltages are with respect to ground (V_{SS}) unless otherwise stated.

		Characteristics	Sym.	Min.	Typ.	Max.	Units	Test Conditions
1	I N P U T S	Supply Current	I_{DD}		52	85	mA	Output unloaded
2		Input High Voltage	V_{IH}	$0.7V_{DD}$			V	
3		Input Low Voltage	V_{IL}			$0.3V_{DD}$	V	
4		Input Leakage (input pins)	I_{IL}			10	μA	$0 \leq V \leq V_{DD}$ See Note 1
		Input Leakage (bi-directional pins)	I_{BL}			50	μA	
5		Input Pin Capacitance	C_I			10	pF	
6	O U T P U T S	Output High Voltage	V_{OH}	$0.8V_{DD}$			V	$I_{OH} = 10mA$
7		Output Low Voltage	V_{OL}			0.4	V	$I_{OL} = 10mA$
8		High Impedance Leakage	I_{OZ}			5	μA	$0 < V < V_{DD}$ See Note 1
9		Output Pin Capacitance	C_O			10	pF	

Note:

1. Maximum leakage on pins (output or I/O pins in high impedance state) is over an applied voltage (V)

AC Electrical Characteristics - Timing Parameter Measurement Voltage Levels

	Characteristics	Sym.	Level	Units	Conditions
1	CMOS Threshold	V_{CT}	$0.5V_{DD}$	V	
2	Rise/Fall Threshold Voltage High	V_{HM}	$0.7V_{DD}$	V	
3	Rise/Fall Threshold Voltage Low	V_{LM}	$0.3V_{DD}$	V	

* Exceeding these values may cause permanent damage. Functional operation under these conditions is not implied

AC Electrical Characteristics - Frame Pulse and CLK

	Characteristic	Sym.	Min.	Typ.	Max.	Units	Notes
1	Frame pulse width	t_{FPW}		60		ns	ST-BUS mode
2	Frame Pulse Setup time before $\overline{C16i}$ falling	t_{FPS}		10		ns	
3	Frame Pulse Hold Time from $\overline{C16i}$ falling	t_{FPH}		10		ns	
4	$\overline{C16i}$ Period	t_{CP}		60		ns	ST-BUS, CT Bus or HMVIP mode
5	$\overline{C16i}$ Pulse Width High	t_{CH}		30		ns	
6	$\overline{C16i}$ Pulse Width Low	t_{CL}		30		ns	
7	Clock Rise/Fall Time	t_r, t_f		10		ns	
8	FPo Frame pulse output width	t_{FPOW}		244		ns	
9	FPo Frame Pulse output setup time before $\overline{C4o}$ falling	t_{FPOS}	10		150	ns	
10	FPo Frame Pulse output Hold Time from $\overline{C4o}$ falling	t_{FPOH}	20	10	150	ns	
11	$\overline{C4o}$ Period	t_{C4OP}		244		ns	
12	$\overline{C4o}$ Pulse Width High	t_{C40H}		122		ns	
13	$\overline{C4o}$ Pulse Width Low	t_{C40L}		122		ns	
14	CT frame pulse width	t_{CFPW}		122		ns	CT Bus mode
15	CT Frame Pulse Setup Time before $\overline{C8i}$ rising	t_{CFPS}	45		90	ns	
16	CT Frame Pulse Hold Time from $\overline{C8i}$ rising	t_{CFPH}	45		90	ns	
17	$\overline{C8i}$ Period	t_{HCP}		122		ns	
18	$\overline{C8i}$ Pulse Width High	t_{HCH}		61		ns	
19	$\overline{C8i}$ Pulse Width Low	t_{HCL}		61		ns	
20	HMVIP frame pulse width	$t_{HF PW}$		244		ns	HMVIP mode
21	Frame Pulse Setup Time before $\overline{C4i}$ falling	t_{HFPS}	50		150	ns	
22	Frame Pulse Hold Time from $\overline{C4i}$ falling	t_{HFPH}	50		150	ns	
23	$\overline{C4i}$ Period	t_{HCP}		244		ns	
24	$\overline{C4i}$ Pulse Width High	t_{HCH}		122		ns	
25	$\overline{C4i}$ Pulse Width Low	t_{HCL}		122		ns	
26	$\overline{C4i}/\overline{C8i}$ Rise/Fall Time	t_{Hr}, t_{Hf}		10		ns	HMVIP or CT Bus mode
27	Delay between falling edge of $\overline{C4i}/\overline{C8i}$ and rising edge of $\overline{C16i}$	t_{DIF}	-10		10	ns	
28	Delay between falling edge of $\overline{C16i}$ and falling edge of $\overline{C4o}$	t_{DC4O}	-10		10	ns	

AC Electrical Characteristics - Serial Streams for Backplane and Local Interfaces

	Characteristic	Sym.	Min.	Typ.	Max.	Units	Test Conditions
1	STio/STi Set-up Time	t_{SIS}	0			ns	
2	STio/STi Hold Time	t_{SIH}	6			ns	
3	STo Delay - Active to Active	t_{SOD}	5	16	32	ns	$C_L=200pF$
4	STo delay - Active to High-Z - High-Z to Active	t_{ZD}			35	ns	$R_L=1K, C_L=200pF, \text{ See Note 1}$
5	Output Driver Enable (ODE) Delay	t_{ODE}			35	ns	

Note:

1. High Impedance is measured by pulling to the appropriate rail with R_L , with timing corrected to cancel time taken to discharge C_L .

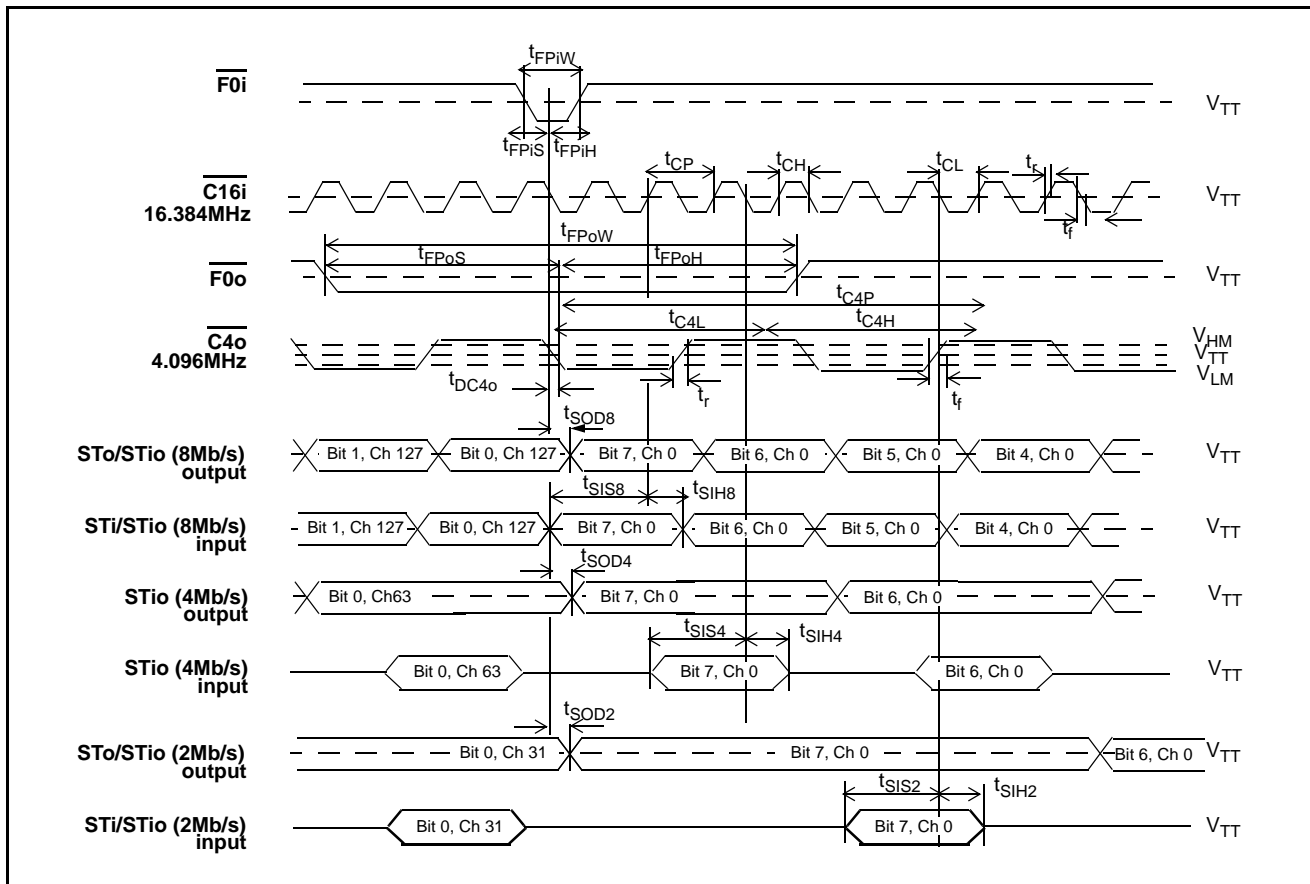

Figure 11 - ST-BUS Timing for Stream rate of 2.048, 4.096 or 8.192 Mb/s

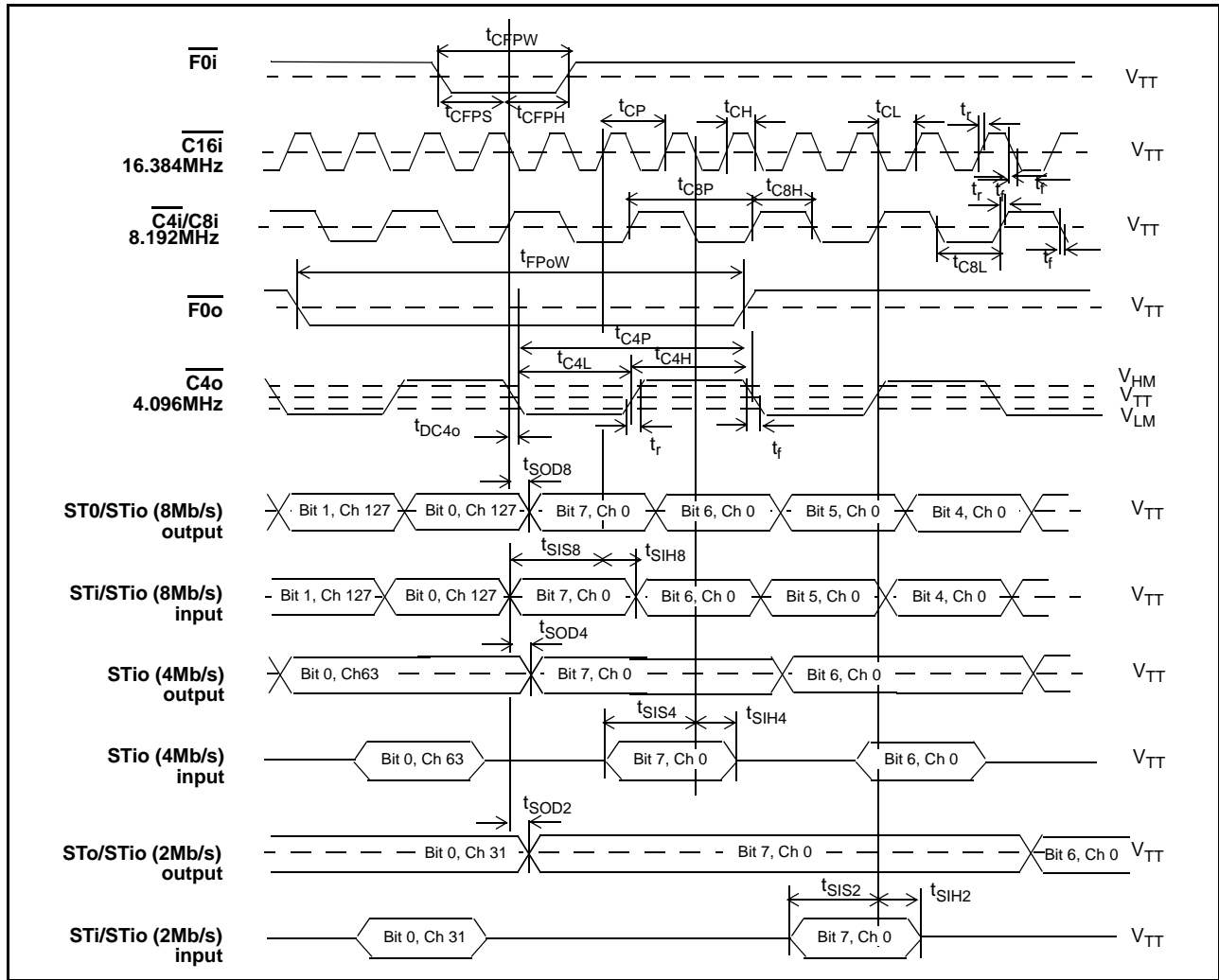

Figure 12 - CT Bus Timing for Stream rate of 2.048, 4.096 or 8.192 Mb/s

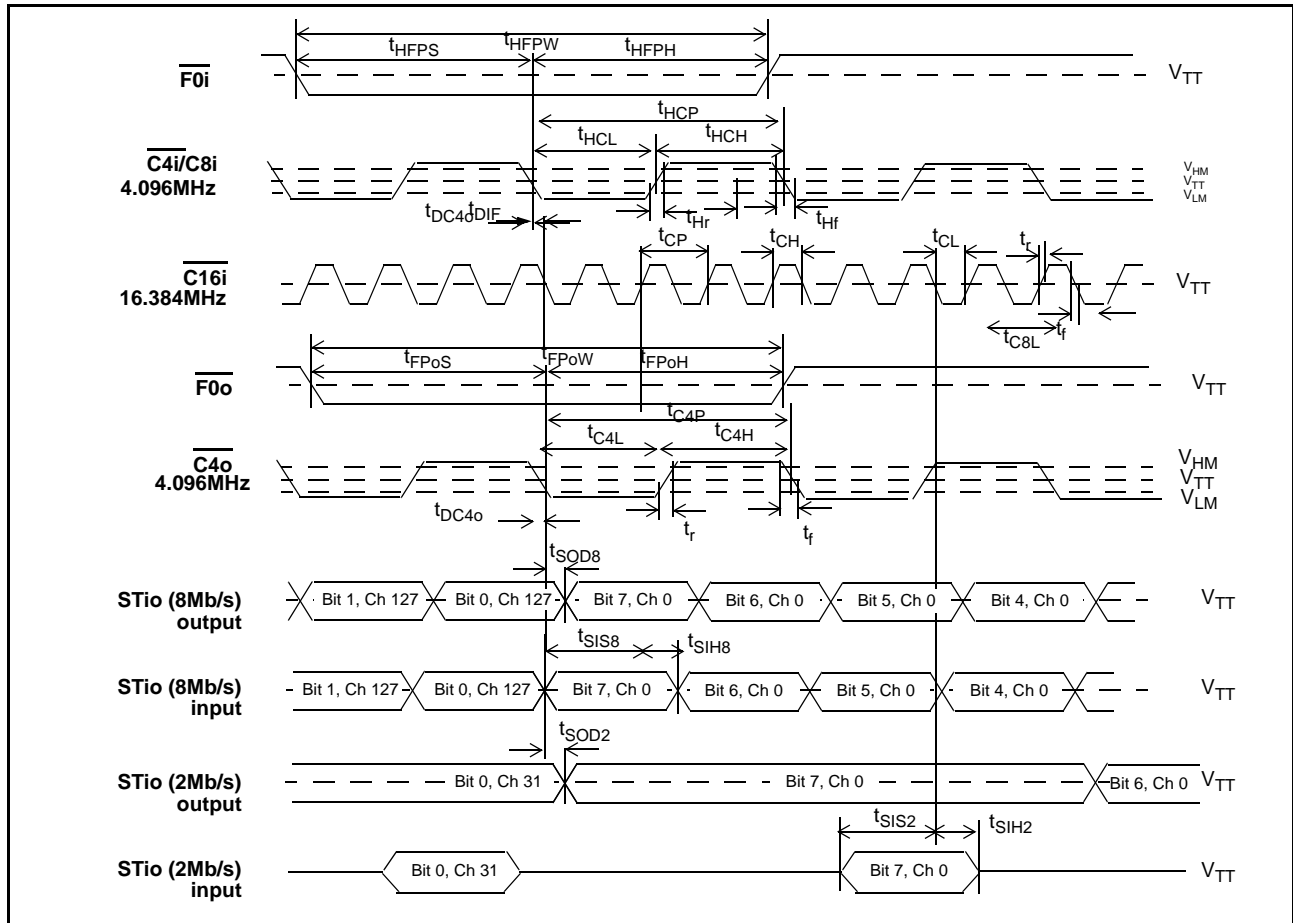

Figure 13 - HMVIP Bus Timing for Stream rate of 2.048 Mb/s or 8.192 Mb/s

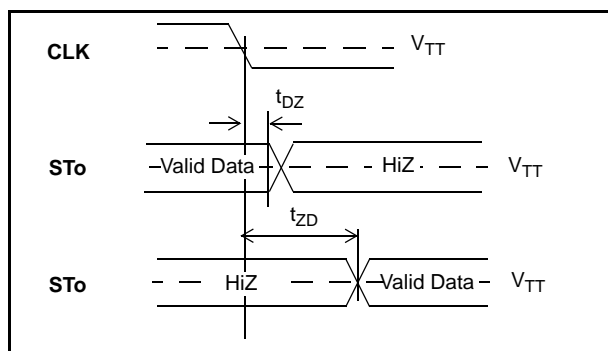

Figure 14 - Serial Output and External Control

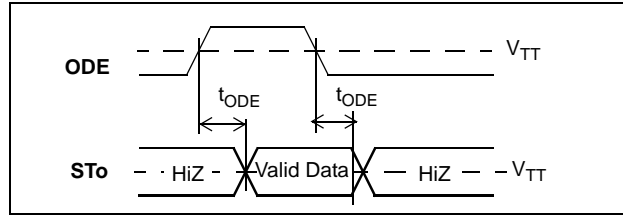

Figure 15 - Output Driver Enable (ODE)

AC Electrical Characteristics - Motorola Non-Multiplexed Bus Mode

	Characteristics	Sym.	Min.	Typ.	Max.	Units	Test Conditions
1	\overline{CS} setup from \overline{DS} falling	t_{CSS}		0		ns	
2	R/W setup from \overline{DS} falling	t_{RWS}		10		ns	
3	Address setup from \overline{DS} falling	t_{ADS}			5	ns	
4	\overline{CS} hold after \overline{DS} rising	t_{CSH}		10		ns	
5	R/W hold after \overline{DS} rising	t_{RWH}		10		ns	
6	Address hold after \overline{DS} rising	t_{ADH}			6	ns	
7	Data setup from \overline{DTA} low on read Reading registers Reading Memory	t_{DDR_REG} t_{DDR_MEM}			16 440	ns	$C_L=50pF$
8	Data hold on read	t_{DHR}			11	ns	$C_L=50pF$, $R_L=1K$ Note 1
9	Data setup on write (fast write)	t_{DSW_REG}			2	ns	
10	Valid data delay on write (slow write)	t_{SWD}			150	ns	
11	Data hold on write	t_{DHW}	5			ns	
12	Acknowledgment delay: Reading/writing registers Reading/writing memory	t_{AKD_REG} t_{AKD_MEM}			40 470	ns	$C_L=50pF$
13	Acknowledgment hold time	t_{AKH}			17	ns	$C_L=50pF$, $R_L=1K$, Note

Note:

1. High Impedance is measured by pulling to the appropriate rail with R_L , with timing corrected to cancel time taken to discharge C_L .

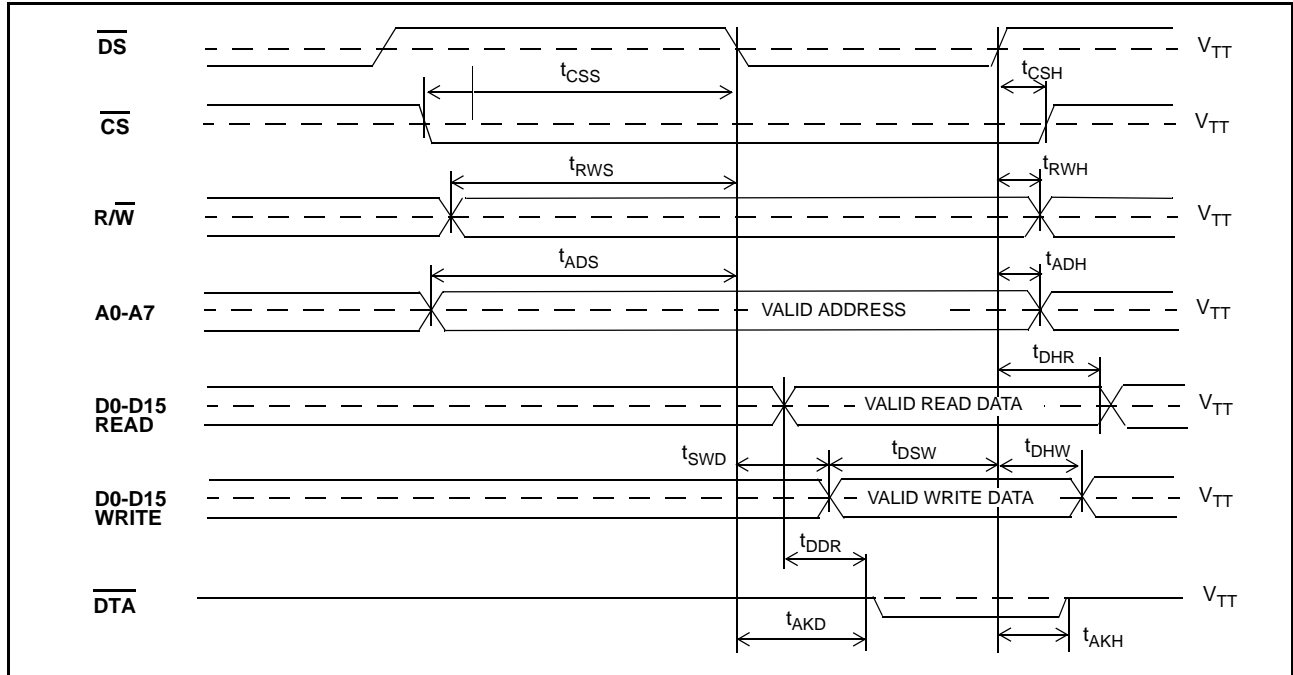
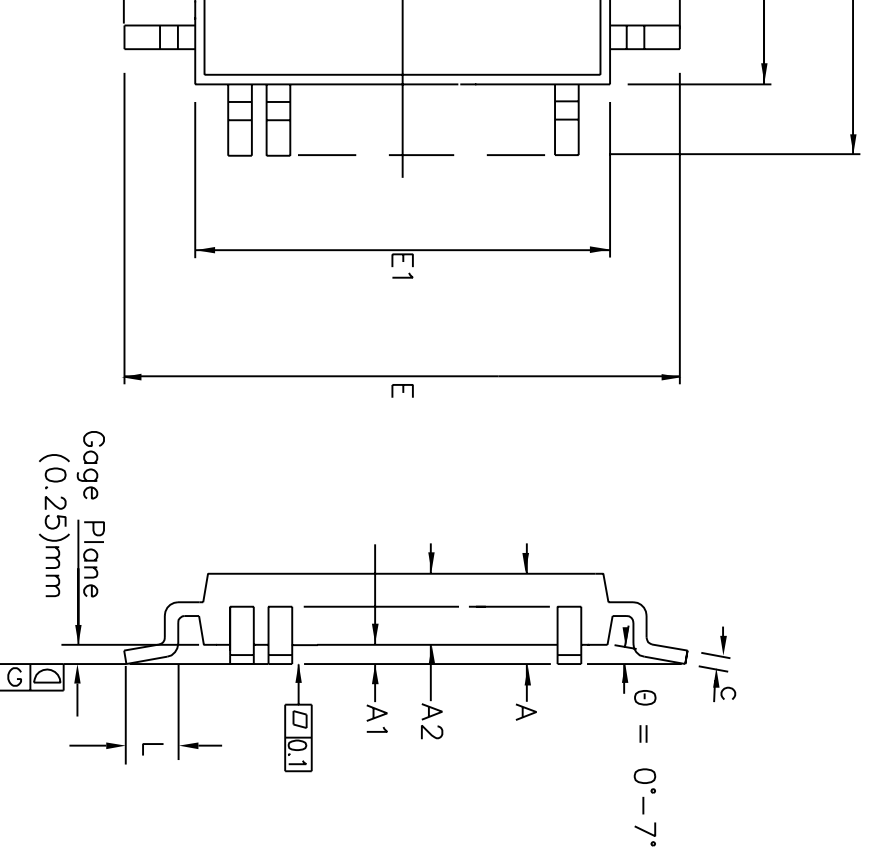

Figure 16 - Motorola Non-Multiplexed Bus Timing



Symbol	Control Dimensions in millimetres		Altern. Dimensions in inches	
	MIN	MAX	MIN	MAX
A	—	4.10	—	0.161
A1	0.25	0.50	0.010	0.020
A2	3.20	3.60	0.126	0.142
D	31.20	BSC	1.228	BSC
D1	28.00	BSC	1.102	BSC
E	31.20	BSC	1.228	BSC
E1	28.00	BSC	1.102	BSC
L	0.73	1.03	0.029	0.041
e	0.80	BSC.	0.031	BSC.
b	0.29	0.45	0.011	0.018
c	0.11	0.23	0.004	0.009
Pin features				
N	128			
ND	32			
NE	32			
NOTE	SQUARE			

Conforms to JEDEC MS-022 DB Iss. B

chamfer, dot or both.
 millimeters.
 be smaller than the bottom package body size by a max. of 0.15 mm.
 include mould protrusion.
 mould protrusion.
 plane G, to be 0.10 mm max.



ZARLINK
SEMICONDUCTOR

Previous package codes

GP / L

Package Code

QB

Package Outline for 128 lead
 MQFP (28 x 28 x 3.4mm)
 3.2mm Footprint

GPD00301

BOTTOM VIEW

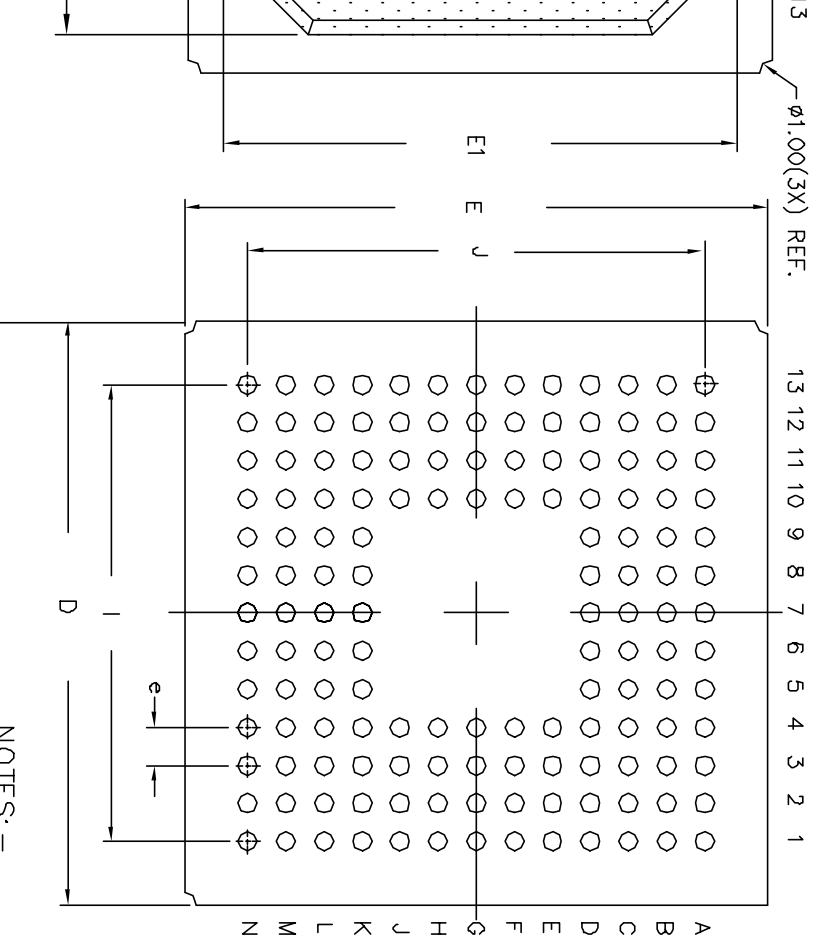

DIMENSION	MIN	MAX
A	2.00	2.26
A1	0.50	0.70
A2	0.97	REF
D	22.80	23.20
D1	20.00	REF
E	22.80	23.20
E1	20.00	REF
b	0.60	0.90
e		1.5
N		144
I		18.00
J		18.00
Substrate Layers: 2		
Reference spec: JEDEC MS-034		

- NOTES:-
1. Controlling dimensions are in MM.
 2. Seating plane is defined by the spherical crown of the solder balls.
 3. Not to scale.
 4. N is the number of solder balls
 5. Substrate thickness is 0.56 MM REF.



ZARLINK
SEMICONDUCTOR

Previous package codes:

BP / G

Package Code : GA

Package Outline for
144Ball PBGA
23x23x2.13mm

GPD000821



**For more information about all Zarlink products
visit our Web Site at
www.zarlink.com**

Information relating to products and services furnished herein by Zarlink Semiconductor Inc. or its subsidiaries (collectively "Zarlink") is believed to be reliable. However, Zarlink assumes no liability for errors that may appear in this publication, or for liability otherwise arising from the application or use of any such information, product or service or for any infringement of patents or other intellectual property rights owned by third parties which may result from such application or use. Neither the supply of such information or purchase of product or service conveys any license, either express or implied, under patents or other intellectual property rights owned by Zarlink or licensed from third parties by Zarlink, whatsoever. Purchasers of products are also hereby notified that the use of product in certain ways or in combination with Zarlink, or non-Zarlink furnished goods or services may infringe patents or other intellectual property rights owned by Zarlink.

This publication is issued to provide information only and (unless agreed by Zarlink in writing) may not be used, applied or reproduced for any purpose nor form part of any order or contract nor to be regarded as a representation relating to the products or services concerned. The products, their specifications, services and other information appearing in this publication are subject to change by Zarlink without notice. No warranty or guarantee express or implied is made regarding the capability, performance or suitability of any product or service. Information concerning possible methods of use is provided as a guide only and does not constitute any guarantee that such methods of use will be satisfactory in a specific piece of equipment. It is the user's responsibility to fully determine the performance and suitability of any equipment using such information and to ensure that any publication or data used is up to date and has not been superseded. Manufacturing does not necessarily include testing of all functions or parameters. These products are not suitable for use in any medical products whose failure to perform may result in significant injury or death to the user. All products and materials are sold and services provided subject to Zarlink's conditions of sale which are available on request.



Purchase of Zarlink's I2C components conveys a license under the Philips I2C Patent rights to use these components in an I2C System, provided that the system conforms to the I2C Standard Specification as defined by Philips.

Zarlink, ZL, the Zarlink Semiconductor logo and the Legerity logo and combinations thereof, VoiceEdge, VoicePort, SLAC, ISLIC, ISLAC and VoicePath are trademarks of Zarlink Semiconductor Inc.

TECHNICAL DOCUMENTATION - NOT FOR RESALE

Looking for pricing, stock, or lifecycle information?

Click below to explore more details on WIN SOURCE:

-  [View MT90863AL1 on WIN SOURCE](#)
-  [Microchip Technology](#) Information

Optimize Your Supply Chain with WIN SOURCE Solutions

-  Global Sourcing Solution
-  Obsolete Management
-  Cost Control Management
-  Shortage Management
-  Alternative Solution
-  Excess Inventory Management