



**THE DATASHEET OF
CY2314ANZSXC-1T**



14 Output, 3.3V SDRAM Buffer for Desktop PCs with 3 DIMMs

Features

- One input to 14 output buffer or driver
- Supports up to three SDRAM DIMMs
- Two additional outputs for feedback
- Serial interface for output control
- Low skew outputs
- Up to 100 MHz operation
- Multiple V_{DD} and V_{SS} pins for noise reduction
- Dedicated OE pin for testing
- Low EMI outputs
- 28-pin SOIC (300-mil) package
- 3.3V operation

Functional Description

The CY2314ANZ is a 3.3V buffer designed to distribute high speed clocks in desktop PC applications. The part has 14 outputs, 12 of which can be used to drive up to three SDRAM DIMMs. The remaining can be used for external feedback to a PLL. The device operates at 3.3V and outputs can run up to 100 MHz.

The CY2314ANZ also includes a serial interface which can enable or disable each output clock. On power up, all output clocks are enabled. A separate Output Enable pin facilitates testing on ATE.

Logic Block Diagram

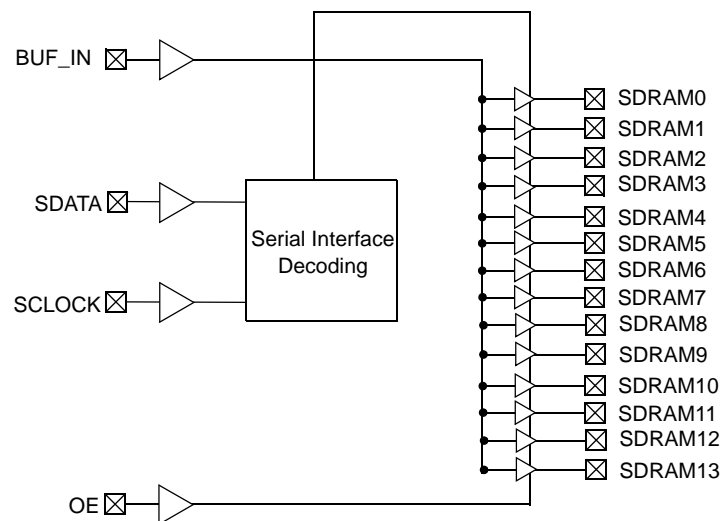

Pin Configuration

Figure 1. 28-Pin SOIC Top View

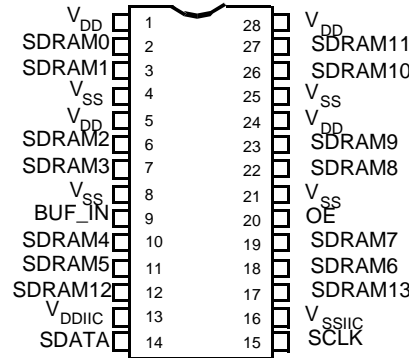

Device Functionality

OE	SDRAM [0-13]
0	High-Z
1	1 x BUF_IN

Serial Configuration Map

- The serial bits are read by the clock driver in the following order:

Byte 0 - Bits 7, 6, 5, 4, 3, 2, 1, 0

Byte 1 - Bits 7, 6, 5, 4, 3, 2, 1, 0

Byte N - Bits 7, 6, 5, 4, 3, 2, 1, 0

- Reserved and unused bits should be programmed to “0”

- Serial interface address for the CY2314ANZ is:

A6	A5	A4	A3	A2	A1	A0	R/W
1	1	0	1	0	0	1	----

Table 1. Byte 0: SDRAM Active/Inactive Register (1 = Enable, 0 = Disable), Default = Enabled

Bit	Pin #	Description
Bit 7	11	SDRAM5 (Active/Inactive)
Bit 6	10	SDRAM4 (Active/Inactive)
Bit 5	--	Reserved, Drive to 0
Bit 4	--	Reserved, Drive to 0
Bit 3	7	SDRAM3 (Active/Inactive)
Bit 2	6	SDRAM2 (Active/Inactive)
Bit 1	3	SDRAM1 (Active/Inactive)
Bit 0	2	SDRAM0 (Active/Inactive)

Table 2. Byte 1: SDRAM Active/Inactive Register (1 = Active, 0 = Inactive), Default = Active

Bit	Pin #	Description
Bit 7	27	SDRAM11 (Active/Inactive)
Bit 6	26	SDRAM10 (Active/Inactive)
Bit 5	23	SDRAM9 (Active/Inactive)
Bit 4	22	SDRAM8 (Active/Inactive)
Bit 3	--	Reserved, Drive to 0
Bit 2	--	Reserved, Drive to 0
Bit 1	19	SDRAM7 (Active/Inactive)
Bit 0	18	SDRAM6 (Active/Inactive)

Table 3. Byte 2: SDRAM Active/Inactive Register (1 = Active, 0 = Inactive), Default = Active

Bit	Pin #	Description
Bit 7	17	SDRAM13 (Active/Inactive)
Bit 6	12	SDRAM12 (Active/Inactive)
Bit 5	--	Reserved, Drive to 0
Bit 4	--	Reserved, Drive to 0
Bit 3	--	Reserved, Drive to 0
Bit 2	--	Reserved, Drive to 0
Bit 1	--	Reserved, Drive to 0
Bit 0	--	Reserved, Drive to 0

Maximum Ratings

Supply Voltage to Ground Potential.....-0.5V to +7.0V
 DC Input Voltage (Except BUF_IN) -0.5V to $V_{DD} + 0.5V$
 DC Input Voltage (BUF_IN)-0.5V to +7.0V

Storage Temperature -65°C to +150°C
 Junction Temperature..... 150°C
 Static Discharge Voltage
 (per MIL-STD-883, Method 3015) >2000V

Operating Conditions ^[1]

Parameter	Description	Min	Max	Unit
V_{DD}	Supply Voltage	3.135	3.465	V
T_A	Operating Temperature (Ambient Temperature)	0	70	°C
C_L	Load Capacitance		30	pF
C_{IN}	Input Capacitance		7	pF
t_{PU}	Power up time for all VDDs to reach minimum specified voltage (power ramps must be monotonic)	0.05	50	ms

Electrical Characteristics Over the Operating Range

Parameter	Description	Test Conditions	Min	Max	Unit
V_{IL}	Input LOW Voltage ^[2]	Except serial interface pins		0.8	V
V_{ILiic}	Input LOW Voltage	For serial interface pins only		0.7	V
V_{IH}	Input HIGH Voltage ^[2]		2.0		V
I_{IL}	Input LOW Current (BUF_IN input)	$V_{IN} = 0V$	-10	10	μA
I_{IL}	Input LOW Current (Except BUF_IN Pin)	$V_{IN} = 0V$		100	μA
I_{IH}	Input HIGH Current	$V_{IN} = V_{DD}$	-10	10	μA
V_{OL}	Output LOW Voltage ^[3]	$I_{OL} = 25\text{ mA}$		0.4	V
V_{OH}	Output HIGH Voltage ^[3]	$I_{OH} = -36\text{ mA}$	2.4		V
I_{DD}	Supply Current ^[3]	Unloaded outputs, 100 MHz		200	mA
I_{DD}	Supply Current ^[3]	Loaded outputs, 100 MHz		290	mA
I_{DD}	Supply Current ^[3]	Unloaded outputs, 66.67 MHz		150	mA
I_{DD}	Supply Current ^[3]	Loaded outputs, 66.67 MHz		185	mA
I_{DDs}	Supply Current	BUF_IN= V_{DD} or V_{SS} All other inputs at V_{DD}		500	μA

Notes

- Electrical parameters are guaranteed under the operating conditions specified.
- BUF_IN input has a threshold voltage of $V_{DD}/2$.
- Parameter is guaranteed by design and characterization. Not 100% tested in production.

Switching Characteristics^[4] Over the Operating Range

Parameter	Name	Test Conditions	Min	Typ	Max	Unit
	Maximum Operating Frequency				100	MHz
	Duty Cycle ^[3, 5] = $t_2 \div t_1$	Measured at 1.5V	45.0	50.0	55.0	%
t_3	Rising Edge Rate ^[3]	Measured between 0.4V and 2.4V	0.9	1.5	4.0	V/ns
t_4	Falling Edge Rate ^[3]	Measured between 2.4V and 0.4V	0.9	1.5	4.0	V/ns
t_5	Output to Output Skew ^[3]	All outputs equally loaded	-250		+250	ps
t_6	SDRAM Buffer LH Propagation Delay ^[3]	Input edge greater than 1 V/ns	1.0	3.5	5.0	ns
t_7	SDRAM Buffer HL Propagation Delay ^[3]	Input edge greater than 1 V/ns	1.0	3.5	5.0	ns
t_8	SDRAM Buffer Enable Delay ^[3]	Input edge greater than 1 V/ns	1.0	5	12	ns
t_9	SDRAM Buffer Disable Delay ^[3]	Input edge greater than 1 V/ns	1.0	20	30	ns

Switching Waveforms

Figure 2. Duty Cycle Timing

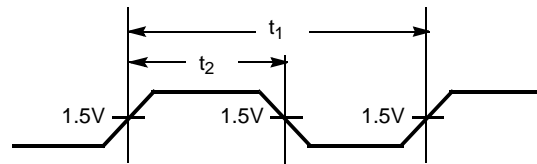

Figure 3. All Outputs Rise/Fall Time

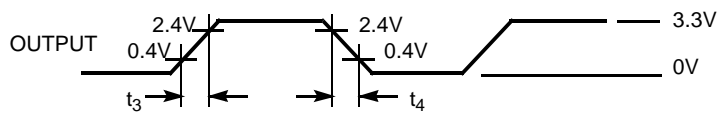
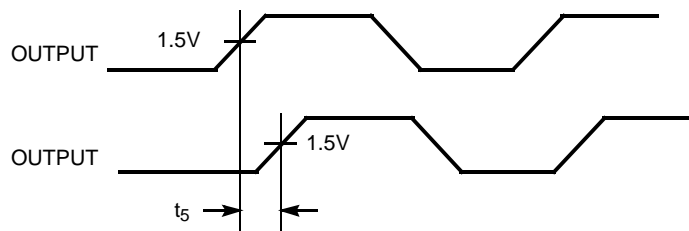

Figure 4. Output-Output Skew



Notes

- 4. All parameters specified with loaded outputs.
- 5. Duty cycle of input clock is 50%. Rising and falling edge rate of the input clock is greater than 1 V/ns.

Switching Waveforms (continued)

Figure 5. SDRAM Buffer LH and HL Propagation Delay

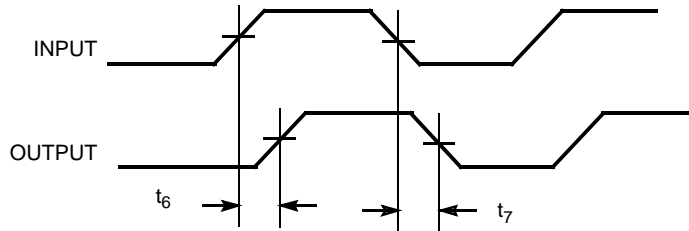
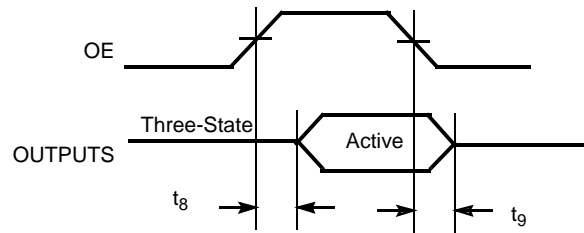
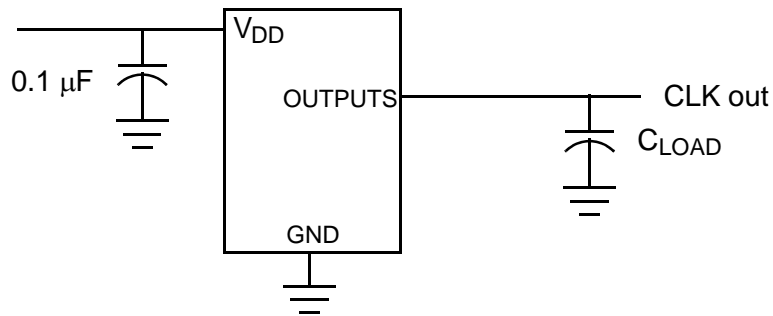

Figure 6. SDRAM Buffer Enable and Disable Times



Test Circuit



Application Information

Clock traces must be terminated with either series or parallel termination, as is normally done.

Figure 7. Application Circuit

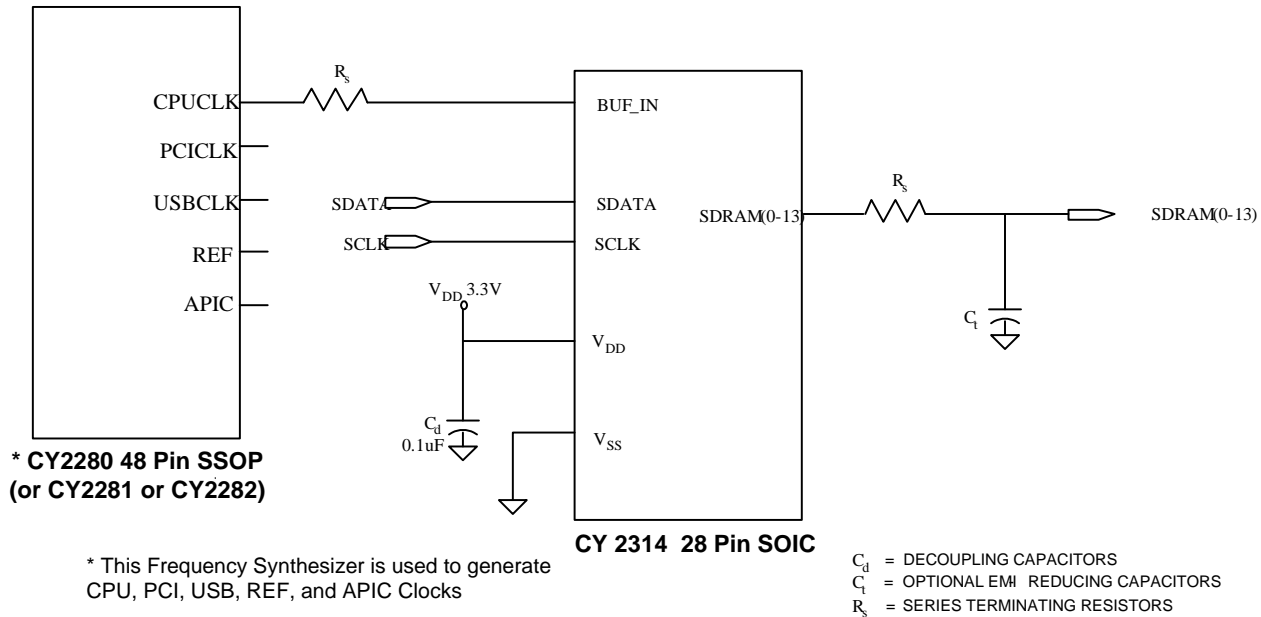

Recommendation

- Surface mount, low ESR, and ceramic capacitors must be used for filtering. Typically, these capacitors have a value of 0.1 μ F. In some cases, smaller value capacitors may be required.
- The value of the series terminating resistor satisfies the following equation, where R_{trace} is the loaded characteristic impedance of the trace, R_{out} is the output impedance of the buffer (typically 25 Ω), and R_{series} is the series terminating resistor.
 $R_{series} > R_{trace} - R_{out}$
- Footprints must be laid out for optional EMI reducing capacitors, which should be placed as close to the terminating resistor as is physically possible. Typical values of these capacitors range from 4.7 pF to 22 pF.
- A ferrite bead **may** be used to isolate the board V_{DD} from the clock generator V_{DD} island. Ensure that the ferrite bead offers greater than 50 Ω impedance at the clock frequency, under loaded DC conditions. Refer to the application note [Layout and Termination Techniques for Cypress Clock Generators](#) for more details.
- If a ferrite bead is used, a 10 μ F to 22 μ F tantalum bypass capacitor should be placed close to the ferrite bead. This capacitor prevents power supply droop during current surges.

Ordering Information

Ordering Code	Package Name	Package Type	Operating Range
Pb-Free			
CY2314ANZSXC-1	SZ283	28-Pin SOIC	Commercial
CY2314ANZSXC-1T	SZ283	28-Pin SOIC - Tape and Reel	Commercial

Package Diagram

Figure 8. 28-Pin (300-Mil) Molded SOIC SZ283

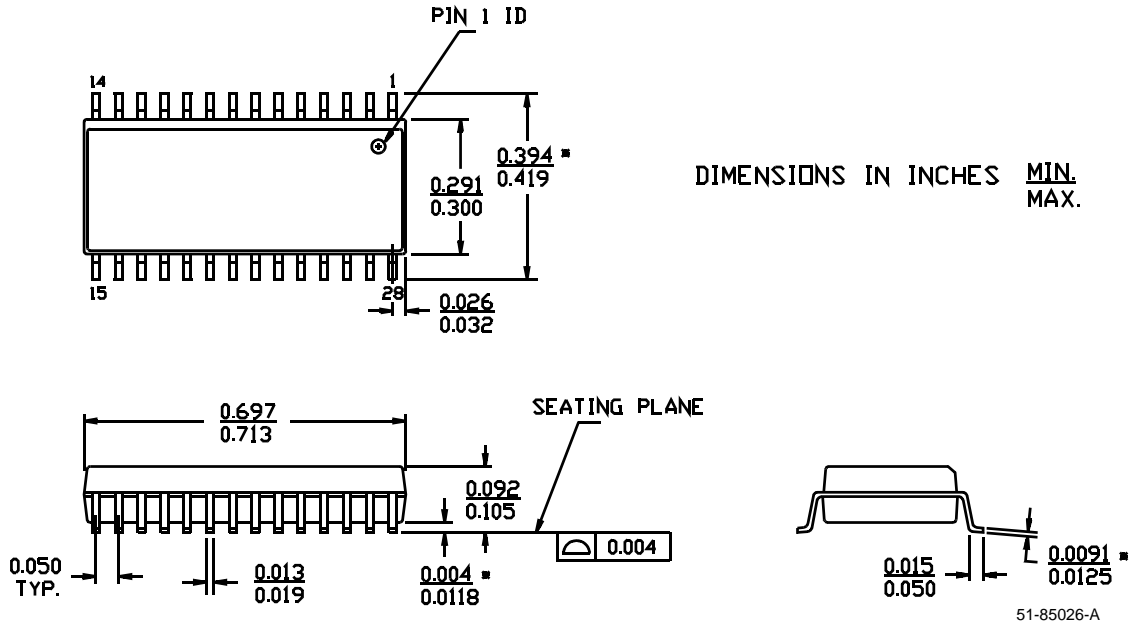

Document History Page

Document Title: CY2314ANZ 14 Output, 3.3V SDRAM Buffer for Desktop PCs with 3 DIMMs				
Document Number: 38-07143				
Rev.	ECN No.	Orig. of Change	Submission Date	Description of Change
**	110252	DSG	11/18/01	Change from Spec number: 38-00687 to 38-07143
*A	121830	RBI	12/14/02	Power up requirements added to Operating Conditions Information
*B	2606695	KVM/PYRS	11/13/08	Update Ordering Information Table: Remove CY2314ANZSC-1 Add Pb-free devices CY2314ANZSXC-1 and CY2314ANZSXC-1T

Sales, Solutions, and Legal Information

Worldwide Sales and Design Support

Cypress maintains a worldwide network of offices, solution centers, manufacturer's representatives, and distributors. To find the office closest to you, visit us at cypress.com/sales.

Products

PSoC	psoc.cypress.com
Clocks & Buffers	clocks.cypress.com
Wireless	wireless.cypress.com
Memories	memory.cypress.com
Image Sensors	image.cypress.com

PSoC Solutions

General	psoc.cypress.com/solutions
Low Power/Low Voltage	psoc.cypress.com/low-power
Precision Analog	psoc.cypress.com/precision-analog
LCD Drive	psoc.cypress.com/lcd-drive
CAN 2.0b	psoc.cypress.com/can
USB	psoc.cypress.com/usb

© Cypress Semiconductor Corporation, 2005-2008. The information contained herein is subject to change without notice. Cypress Semiconductor Corporation assumes no responsibility for the use of any circuitry other than circuitry embodied in a Cypress product. Nor does it convey or imply any license under patent or other rights. Cypress products are not warranted nor intended to be used for medical, life support, life saving, critical control or safety applications, unless pursuant to an express written agreement with Cypress. Furthermore, Cypress does not authorize its products for use as critical components in life-support systems where a malfunction or failure may reasonably be expected to result in significant injury to the user. The inclusion of Cypress products in life-support systems application implies that the manufacturer assumes all risk of such use and in doing so indemnifies Cypress against all charges.

Any Source Code (software and/or firmware) is owned by Cypress Semiconductor Corporation (Cypress) and is protected by and subject to worldwide patent protection (United States and foreign), United States copyright laws and international treaty provisions. Cypress hereby grants to licensee a personal, non-exclusive, non-transferable license to copy, use, modify, create derivative works of, and compile the Cypress Source Code and derivative works for the sole purpose of creating custom software and or firmware in support of licensee product to be used only in conjunction with a Cypress integrated circuit as specified in the applicable agreement. Any reproduction, modification, translation, compilation, or representation of this Source Code except as specified above is prohibited without the express written permission of Cypress.

Disclaimer: CYPRESS MAKES NO WARRANTY OF ANY KIND, EXPRESS OR IMPLIED, WITH REGARD TO THIS MATERIAL, INCLUDING, BUT NOT LIMITED TO, THE IMPLIED WARRANTIES OF MERCHANTABILITY AND FITNESS FOR A PARTICULAR PURPOSE. Cypress reserves the right to make changes without further notice to the materials described herein. Cypress does not assume any liability arising out of the application or use of any product or circuit described herein. Cypress does not authorize its products for use as critical components in life-support systems where a malfunction or failure may reasonably be expected to result in significant injury to the user. The inclusion of Cypress' product in a life-support systems application implies that the manufacturer assumes all risk of such use and in doing so indemnifies Cypress against all charges.

Use may be limited by and subject to the applicable Cypress software license agreement.

Looking for pricing, stock, or lifecycle information?

Click below to explore more details on WIN SOURCE:

-  [View CY2314ANZSXC-1T on WIN SOURCE](#)
-  [Cypress Semiconductor Corp Information](#)

Optimize Your Supply Chain with WIN SOURCE Solutions

-  Global Sourcing Solution
-  Obsolete Management
-  Cost Control Management
-  Shortage Management
-  Alternative Solution
-  Excess Inventory Management