



THE DATASHEET OF CDC340DW



CDC340 1-LINE TO 8-LINE CLOCK DRIVER

SCAS332B – DECEMBER 1992 – REVISED MAY 1997

- Low Output Skew, Low Pulse Skew for Clock-Distribution and Clock-Generation Applications
- TTL-Compatible Inputs and Outputs
- Distributes One Clock Input to Eight Outputs
- Distributed V_{CC} and Ground Pins Reduce Switching Noise
- High-Drive Outputs ($-48\text{-mA } I_{OH}$, $48\text{-mA } I_{OL}$)
- State-of-the-Art EPIC-IIB™ BiCMOS Design Significantly Reduces Power Dissipation
- Package Options Include Plastic Small-Outline (DW) and Shrink

DW PACKAGE
(TOP VIEW)

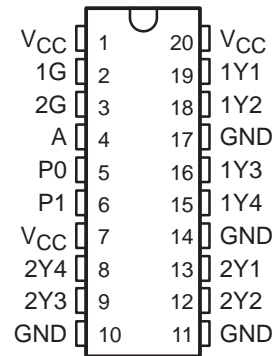

description

The CDC340 is a high-performance clock-driver circuit that distributes one (A) input signal to eight (Y) outputs with minimum skew for clock distribution. Through the use of the control pins (1G and 2G), the outputs can be placed in a high state regardless of the A input.

The propagation delays are adjusted at the factory using the P0 and P1 pins. These pins are not intended for customer use and should be strapped to GND.

The CDC340 is characterized for operation from 0°C to 70°C.

FUNCTION TABLE

INPUTS			OUTPUTS	
1G	2G	A	1Y1–1Y4	2Y1–2Y4
X	X	L	H	H
L	L	H	H	H
L	H	H	H	L
H	L	H	L	H
H	H	H	L	L



Please be aware that an important notice concerning availability, standard warranty, and use in critical applications of Texas Instruments semiconductor products and disclaimers thereto appears at the end of this data sheet.

EPIC-IIB is a trademark of Texas Instruments Incorporated.

PRODUCTION DATA information is current as of publication date. Products conform to specifications per the terms of Texas Instruments standard warranty. Production processing does not necessarily include testing of all parameters.

 **TEXAS
INSTRUMENTS**

POST OFFICE BOX 655303 • DALLAS, TEXAS 75265

Copyright © 1997, Texas Instruments Incorporated

CDC340 1-LINE TO 8-LINE CLOCK DRIVER

SCAS332B – DECEMBER 1992 – REVISED MAY 1997

logic symbol†

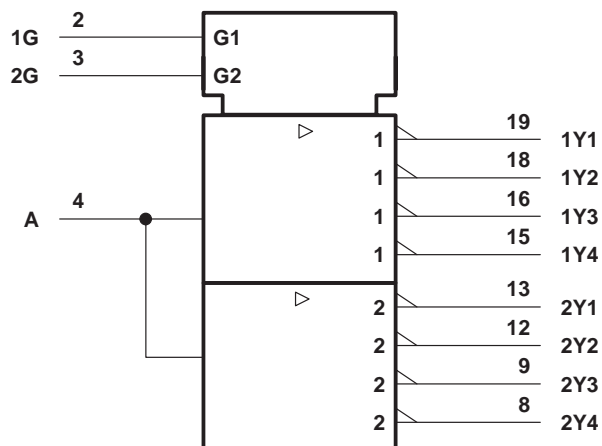

† This symbol is in accordance with ANSI/IEEE Std 91-1984 and IEC Publication 617-12.

logic diagram (positive logic)

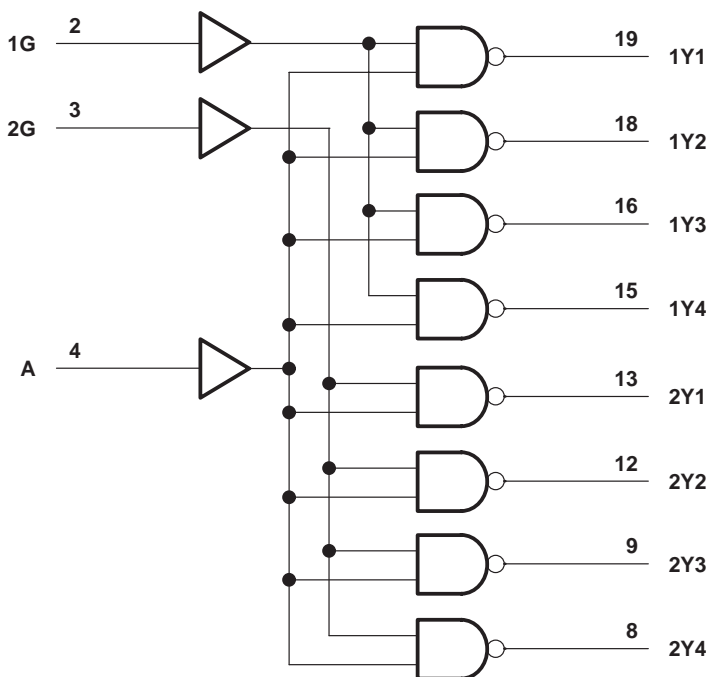

absolute maximum ratings over operating free-air temperature range (unless otherwise noted)†

Supply voltage range, V_{CC}	–0.5 V to 7 V
Input voltage range, V_I (see Note 1)	–0.5 V to 7 V
Voltage range applied to any output in the high state or power-off state, V_O (see Note 1)	–0.5 V to $V_{CC} + 0.5$ V
Current into any output in the low state, I_O	96 mA
Input clamp current, I_{IK} ($V_I < 0$)	–18 mA
Maximum power dissipation at $T_A = 55^\circ\text{C}$ (in still air) (see Note 2): DW package	1.6 W
Storage temperature range, T_{stg}	–65°C to 150°C

† Stresses beyond those listed under “absolute maximum ratings” may cause permanent damage to the device. These are stress ratings only and functional operation of the device at these or any other conditions beyond those indicated under “recommended operating conditions” is not implied. Exposure to absolute-maximum-rated conditions for extended periods may affect device reliability.

- NOTES: 1. The input and output negative-voltage ratings may be exceeded if the input and output clamp-current ratings are observed.
 2. The maximum package power dissipation is calculated using a junction temperature of 150°C and a board trace length of 750 mils.
 For more information, refer to the *Package Thermal Considerations* Application Note in the *ABT Advanced BiCMOS Technology Data Book*, literature number SCBD002.

recommended operating conditions (see Note 3)

		MIN	MAX	UNIT
V_{CC}	Supply voltage	4.75	5.25	V
V_{IH}	High-level input voltage	2		V
V_{IL}	Low-level input voltage		0.8	V
V_I	Input voltage	0	V_{CC}	V
I_{OH}	High-level output current		–48	mA
I_{OL}	Low-level output current		48	mA
f_{clock}	Input clock frequency	One output back loaded		MHz
		Both output banks loaded		
T_A	Operating free-air temperature	0	70	°C

NOTE 3: Unused inputs must be held high or low to prevent them from floating.

electrical characteristics over recommended operating free-air temperature range (unless otherwise noted)

PARAMETER	TEST CONDITIONS	$T_A = 25^\circ\text{C}$			MIN	MAX	UNIT
		MIN	TYP‡	MAX			
V_{IK}	$V_{CC} = 4.75$ V, $I_I = -18$ mA			–1.2	–1.2	V	
V_{OH}	$V_{CC} = 4.75$ V, $I_{OH} = -3$ mA	2.5			2.5	V	
	$V_{CC} = 5$ V, $I_{OH} = -3$ mA	3			3		
	$V_{CC} = 4.75$ V, $I_{OH} = -48$ mA	2			2		
V_{OL}	$V_{CC} = 4.75$ V, $I_{OL} = 48$ mA				0.5	V	
I_I	$V_{CC} = 5.25$ V, $V_I = V_{CC}$ or GND			± 1	± 1	μA	
I_O^{\S}	$V_{CC} = 5.25$ V, $V_O = 2.5$ V	–50	–100	–200	–50	–200	mA
I_{CC}	$V_{CC} = 5.25$ V, $V_I = V_{CC}$ or GND, $I_O = 0$,	Outputs high	2		3.5		mA
		Outputs low	24		33		
C_i	$V_I = 2.5$ V or 0.5 V	3					pF

‡ All typical values are at $V_{CC} = 5$ V.

§ No more than one output should be tested at a time, and the duration of the test should not exceed one second.

CDC340

1-LINE TO 8-LINE CLOCK DRIVER

SCAS332B – DECEMBER 1992 – REVISED MAY 1997

switching characteristics, $C_L = 50$ pF (see Figure 1 and Figure 2)

PARAMETER		FROM (INPUT)	TO (OUTPUT)	$V_{CC} = 5$ V, $T_A = 25^\circ$ C			$V_{CC} = 4.75$ V to 5.25 V, $T_A = 0^\circ$ C to 70° C		UNIT
				MIN	TYP	MAX	MIN	MAX	
t_{PLH}	Propagation delay time, low-to-high level	A	Y	3.4	4.5	3	4.8	ns	
t_{PHL}	Propagation delay time, high-to-low level			3.2	4.3	2.8	4.7		
t_{PLH}	Propagation delay time, low-to-high level	G	Y	2	3.8	2	4	ns	
t_{PHL}	Propagation delay time, high-to-low level			2	3.8	2	4		
$t_{sk(o)}$	Skew time, output	A	Y	0.3	0.5	0.6		ns	
$t_{sk(p)}$	Skew time, pulse			0.6	0.8	0.9			
$t_{sk(pr)}$	Skew time, process			1.1		1.1			
t_r	Rise time	A	Y				1.5	ns	
t_f	Fall time	A	Y				1.5	ns	

t_{pd} performance information relative to V_{CC} and temperature variation (see Note 4)

PARAMETER		Δ change
$\Delta t_{PLH(TA)}^\dagger$	Temperature drift of t_{PLH} from 0° C to 70° C	-53 ps/ 10° C
$\Delta t_{PHL(TA)}^\dagger$	Temperature drift of t_{PHL} from 0° C to 70° C	-58 ps/ 10° C
$\Delta t_{PLH(VCC)}^\ddagger$	V_{CC} drift of t_{PLH} from 4.75 V to 5.25 V	43 ps/100 mV
$\Delta t_{PHL(VCC)}^\ddagger$	V_{CC} drift of t_{PHL} from 4.75 V to 5.25 V	-33 ps/100 mV

† Virtually independent of V_{CC}

‡ Virtually independent of temperature

NOTE 4: The data extracted is from a wide range of characterization material.

PARAMETER MEASUREMENT INFORMATION

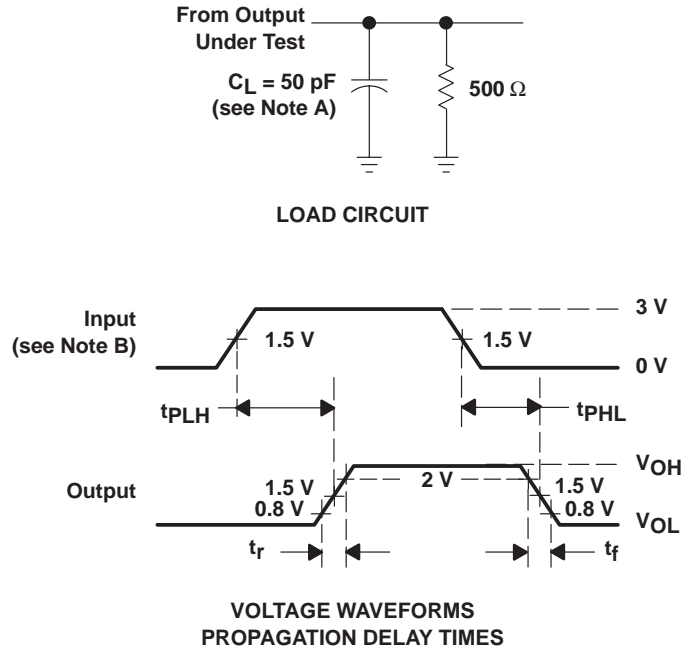

- NOTES: A. C_L includes probe and jig capacitance.
B. All input pulses are supplied by generators having the following characteristics: PRR \leq 10 MHz, $Z_O = 50 \Omega$, $t_r \leq 2.5 \text{ ns}$, $t_f \leq 2.5 \text{ ns}$.

Figure 1. Load Circuit and Voltage Waveforms

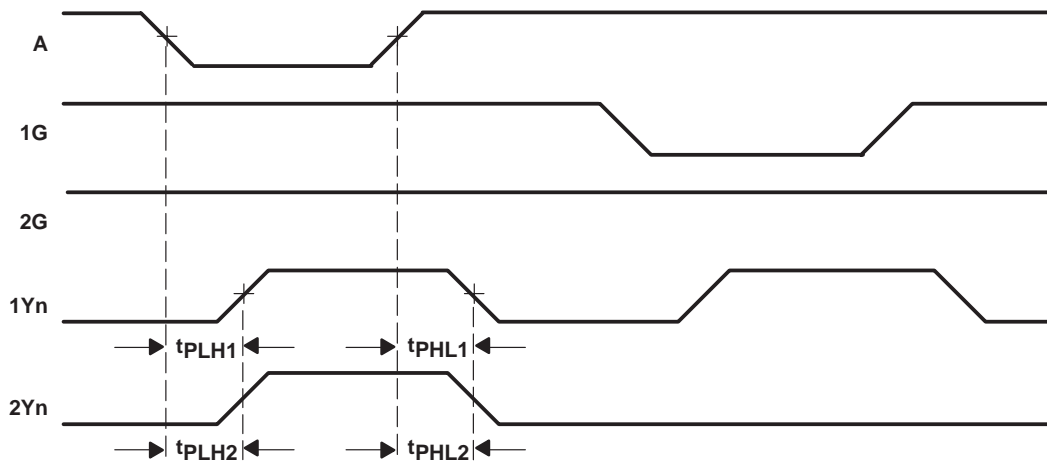

- NOTES: A. Output skew, $t_{sk(o)}$, is calculated as the greater of:
– The difference between the fastest and slowest of t_{PLHn} ($n = 1, 2$)
– The difference between the fastest and slowest of t_{PHLn} ($n = 1, 2$)
B. Pulse skew, $t_{sk(p)}$, is calculated as the greater of $|t_{PLHn} - t_{PHLn}|$ ($n = 1, 2$).
C. Process skew, $t_{sk(pr)}$, is calculated as the greater of:
– The difference between the fastest and slowest of t_{PLHn} ($n = 1, 2$) across multiple devices under identical operating conditions
– The difference between the fastest and slowest of t_{PHLn} ($n = 1, 2$) across multiple devices under identical operating conditions

Figure 2. Waveforms for Calculation of $t_{sk(o)}$, $t_{sk(p)}$, $t_{sk(pr)}$

CDC340 1-LINE TO 8-LINE CLOCK DRIVER

SCAS332B – DECEMBER 1992 – REVISED MAY 1997

MECHANICAL INFORMATION

DW (R-PDSO-G**)

PLASTIC SMALL-OUTLINE PACKAGE

16 PIN SHOWN

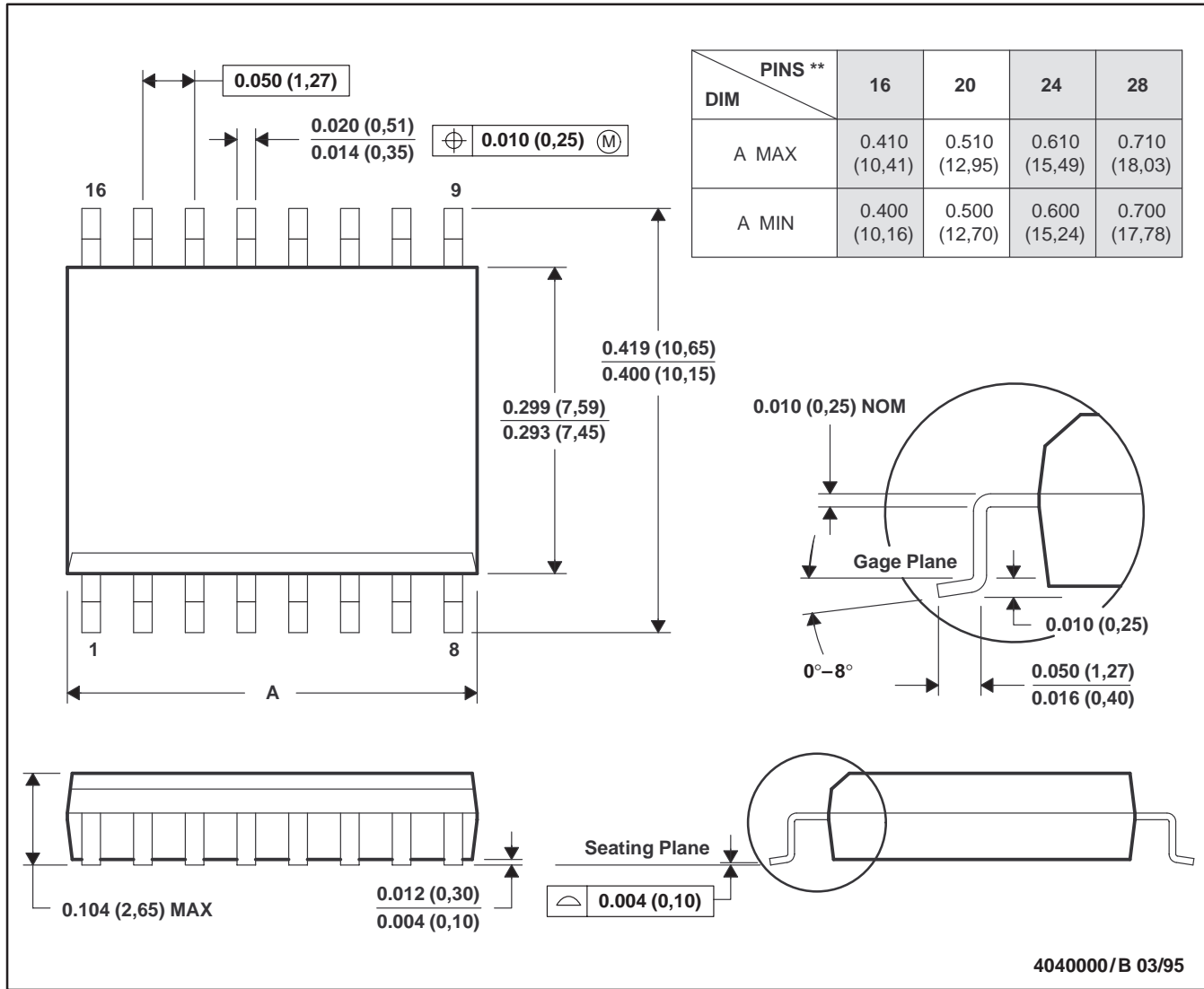

- NOTES: A. All linear dimensions are in inches (millimeters).
 B. This drawing is subject to change without notice.
 C. Body dimensions do not include mold flash or protrusion not to exceed 0.006 (0,15).
 D. Falls within JEDEC MS-013

PACKAGING INFORMATION

Orderable Device	Status ⁽¹⁾	Package Type	Package Drawing	Pins	Package Qty	Eco Plan ⁽²⁾	Lead/Ball Finish	MSL Peak Temp ⁽³⁾
CDC340DBLE	OBSOLETE	SSOP	DB	20		TBD	Call TI	Call TI
CDC340DW	ACTIVE	SOIC	DW	20	25	Green (RoHS & no Sb/Br)	CU NIPDAU	Level-1-260C-UNLIM
CDC340DWG4	ACTIVE	SOIC	DW	20	25	Green (RoHS & no Sb/Br)	CU NIPDAU	Level-1-260C-UNLIM

⁽¹⁾ The marketing status values are defined as follows:

ACTIVE: Product device recommended for new designs.

LIFEBUY: TI has announced that the device will be discontinued, and a lifetime-buy period is in effect.

NRND: Not recommended for new designs. Device is in production to support existing customers, but TI does not recommend using this part in a new design.

PREVIEW: Device has been announced but is not in production. Samples may or may not be available.

OBSOLETE: TI has discontinued the production of the device.

⁽²⁾ Eco Plan - The planned eco-friendly classification: Pb-Free (RoHS), Pb-Free (RoHS Exempt), or Green (RoHS & no Sb/Br) - please check <http://www.ti.com/productcontent> for the latest availability information and additional product content details.

TBD: The Pb-Free/Green conversion plan has not been defined.

Pb-Free (RoHS): TI's terms "Lead-Free" or "Pb-Free" mean semiconductor products that are compatible with the current RoHS requirements for all 6 substances, including the requirement that lead not exceed 0.1% by weight in homogeneous materials. Where designed to be soldered at high temperatures, TI Pb-Free products are suitable for use in specified lead-free processes.

Pb-Free (RoHS Exempt): This component has a RoHS exemption for either 1) lead-based flip-chip solder bumps used between the die and package, or 2) lead-based die adhesive used between the die and leadframe. The component is otherwise considered Pb-Free (RoHS compatible) as defined above.

Green (RoHS & no Sb/Br): TI defines "Green" to mean Pb-Free (RoHS compatible), and free of Bromine (Br) and Antimony (Sb) based flame retardants (Br or Sb do not exceed 0.1% by weight in homogeneous material)

⁽³⁾ MSL, Peak Temp. -- The Moisture Sensitivity Level rating according to the JEDEC industry standard classifications, and peak solder temperature.

Important Information and Disclaimer:The information provided on this page represents TI's knowledge and belief as of the date that it is provided. TI bases its knowledge and belief on information provided by third parties, and makes no representation or warranty as to the accuracy of such information. Efforts are underway to better integrate information from third parties. TI has taken and continues to take reasonable steps to provide representative and accurate information but may not have conducted destructive testing or chemical analysis on incoming materials and chemicals. TI and TI suppliers consider certain information to be proprietary, and thus CAS numbers and other limited information may not be available for release.

In no event shall TI's liability arising out of such information exceed the total purchase price of the TI part(s) at issue in this document sold by TI to Customer on an annual basis.

IMPORTANT NOTICE

Texas Instruments Incorporated and its subsidiaries (TI) reserve the right to make corrections, modifications, enhancements, improvements, and other changes to its products and services at any time and to discontinue any product or service without notice. Customers should obtain the latest relevant information before placing orders and should verify that such information is current and complete. All products are sold subject to TI's terms and conditions of sale supplied at the time of order acknowledgment.

TI warrants performance of its hardware products to the specifications applicable at the time of sale in accordance with TI's standard warranty. Testing and other quality control techniques are used to the extent TI deems necessary to support this warranty. Except where mandated by government requirements, testing of all parameters of each product is not necessarily performed.

TI assumes no liability for applications assistance or customer product design. Customers are responsible for their products and applications using TI components. To minimize the risks associated with customer products and applications, customers should provide adequate design and operating safeguards.

TI does not warrant or represent that any license, either express or implied, is granted under any TI patent right, copyright, mask work right, or other TI intellectual property right relating to any combination, machine, or process in which TI products or services are used. Information published by TI regarding third-party products or services does not constitute a license from TI to use such products or services or a warranty or endorsement thereof. Use of such information may require a license from a third party under the patents or other intellectual property of the third party, or a license from TI under the patents or other intellectual property of TI.

Reproduction of TI information in TI data books or data sheets is permissible only if reproduction is without alteration and is accompanied by all associated warranties, conditions, limitations, and notices. Reproduction of this information with alteration is an unfair and deceptive business practice. TI is not responsible or liable for such altered documentation. Information of third parties may be subject to additional restrictions.

Resale of TI products or services with statements different from or beyond the parameters stated by TI for that product or service voids all express and any implied warranties for the associated TI product or service and is an unfair and deceptive business practice. TI is not responsible or liable for any such statements.

TI products are not authorized for use in safety-critical applications (such as life support) where a failure of the TI product would reasonably be expected to cause severe personal injury or death, unless officers of the parties have executed an agreement specifically governing such use. Buyers represent that they have all necessary expertise in the safety and regulatory ramifications of their applications, and acknowledge and agree that they are solely responsible for all legal, regulatory and safety-related requirements concerning their products and any use of TI products in such safety-critical applications, notwithstanding any applications-related information or support that may be provided by TI. Further, Buyers must fully indemnify TI and its representatives against any damages arising out of the use of TI products in such safety-critical applications.

TI products are neither designed nor intended for use in military/aerospace applications or environments unless the TI products are specifically designated by TI as military-grade or "enhanced plastic." Only products designated by TI as military-grade meet military specifications. Buyers acknowledge and agree that any such use of TI products which TI has not designated as military-grade is solely at the Buyer's risk, and that they are solely responsible for compliance with all legal and regulatory requirements in connection with such use.

TI products are neither designed nor intended for use in automotive applications or environments unless the specific TI products are designated by TI as compliant with ISO/TS 16949 requirements. Buyers acknowledge and agree that, if they use any non-designated products in automotive applications, TI will not be responsible for any failure to meet such requirements.

Following are URLs where you can obtain information on other Texas Instruments products and application solutions:

Products

Amplifiers	amplifier.ti.com
Data Converters	dataconverter.ti.com
DSP	dsp.ti.com
Clocks and Timers	www.ti.com/clocks
Interface	interface.ti.com
Logic	logic.ti.com
Power Mgmt	power.ti.com
Microcontrollers	microcontroller.ti.com
RFID	www.ti-rfid.com
RF/IF and ZigBee® Solutions	www.ti.com/lprf

Applications

Audio	www.ti.com/audio
Automotive	www.ti.com/automotive
Broadband	www.ti.com/broadband
Digital Control	www.ti.com/digitalcontrol
Medical	www.ti.com/medical
Military	www.ti.com/military
Optical Networking	www.ti.com/opticalnetwork
Security	www.ti.com/security
Telephony	www.ti.com/telephony
Video & Imaging	www.ti.com/video
Wireless	www.ti.com/wireless

Mailing Address: Texas Instruments, Post Office Box 655303, Dallas, Texas 75265
Copyright © 2008, Texas Instruments Incorporated

Looking for pricing, stock, or lifecycle information?

Click below to explore more details on WIN SOURCE:

 [View CDC340DW](#) on WIN SOURCE

 [Texas Instruments](#) Information

Optimize Your Supply Chain with WIN SOURCE Solutions

-  Global Sourcing Solution
-  Obsolete Management
-  Cost Control Management
-  Shortage Management
-  Alternative Solution
-  Excess Inventory Management