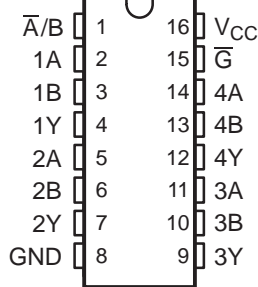
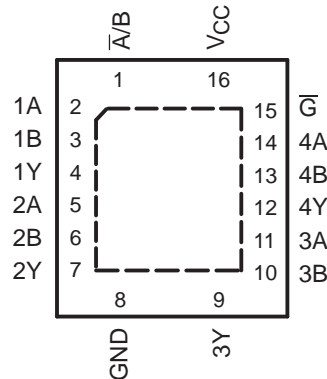
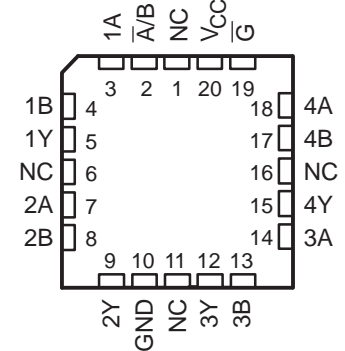

QUADRUPLE 2-LINE TO 1-LINE DATA SELECTORS/MULTIPLEXERS

 Check for Samples: [SN54LVC157A](#), [SN74LVC157A](#)

FEATURES

- Operate From 1.65 V to 3.6 V
- Specified From -40°C to 85°C , -40°C to 125°C , and -55°C to 125°C
- Inputs Accept Voltages to 5.5 V
- Max t_{pd} of 5.2 ns at 3.3 V
- Typical V_{OLP} (Output Ground Bounce) $< 0.8\text{ V}$ at $V_{CC} = 3.3\text{ V}$, $T_A = 25^{\circ}\text{C}$
- Typical V_{OHV} (Output V_{OH} Undershoot) $> 2\text{ V}$ at $V_{CC} = 3.3\text{ V}$, $T_A = 25^{\circ}\text{C}$
- Latch-Up Performance Exceeds 250 mA Per JESD 17
- ESD Protection Exceeds JESD 22
 - 2000-V Human-Body Model (A114-A)
 - 200-V Machine Model (A115-A)
 - 1000-V Charged-Device Model (C101)

 SN54LVC157A... J OR W PACKAGE
 SN74LVC157A... D, DB, NS,
 OR PW PACKAGE
 (TOP VIEW)

 SN74LVC157A... RGY PACKAGE
 (TOP VIEW)

 SN54LVC157A... FK PACKAGE
 (TOP VIEW)

NC - No internal connection

DESCRIPTION/ORDERING INFORMATION

 These quadruple 2-line to 1-line data selectors/multiplexers are designed for 1.65-V to 3.6-V V_{CC} operation.

 The 'LVC157A devices feature a common strobe (\overline{G}) input. When \overline{G} is high, all outputs are low. When \overline{G} is low, a 4-bit word is selected from one of two sources and is routed to the four outputs. The devices provide true data.

Please be aware that an important notice concerning availability, standard warranty, and use in critical applications of Texas Instruments semiconductor products and disclaimers thereto appears at the end of this data sheet.

ORDERING INFORMATION

| T _A | PACKAGE ⁽¹⁾ | | ORDERABLE PART NUMBER | TOP-SIDE MARKING |
|----------------|------------------------|----------------|-----------------------|------------------|
| -40°C to 85°C | QFN – RGY | Reel of 1000 | SN74LVC157ARGYR | LC157A |
| -40°C to 125°C | SOIC – D | Tube of 40 | SN74LVC157AD | LVC157A |
| | | Reel of 2500 | SN74LVC157ADRG3 | |
| | | Reel of 250 | SN74LVC157ADT | |
| | SOP – NS | Reel of 2000 | SN74LVC157ANSR | LVC157A |
| | SSOP – DB | Reel of 2000 | SN74LVC157ADBR | LC157A |
| | TSSOP – PW | Tube of 90 | SN74LVC157APW | LC157A |
| | | Reel of 2000 | SN74LVC157APWR | |
| Reel of 250 | | SN74LVC157APWT | | |
| -55°C to 125°C | CDIP – J | Tube of 25 | SNJ54LVC157AJ | SNJ54LVC157AJ |
| | CFP – W | Tube of 150 | SNJ54LVC157AW | SNJ54LVC157AW |
| | LCCC – FK | Tube of 55 | SNJ54LVC157AFK | SNJ54LVC157AFK |

(1) Package drawings, standard packing quantities, thermal data, symbolization, and PCB design guidelines are available at www.ti.com/sc/package.

DESCRIPTION/ORDERING INFORMATION (CONTINUED)

Inputs can be driven from either 3.3-V or 5-V devices. This feature allows the use of these devices as translators in a mixed 3.3-V/5-V system environment.

FUNCTION TABLE

| INPUTS | | | | OUTPUT |
|-----------|-------------|---|---|--------|
| \bar{G} | \bar{A}/B | A | B | Y |
| H | X | X | X | L |
| L | L | L | X | L |
| L | L | H | X | H |
| L | H | X | L | L |
| L | H | X | H | H |

LOGIC DIAGRAM (POSITIVE LOGIC)

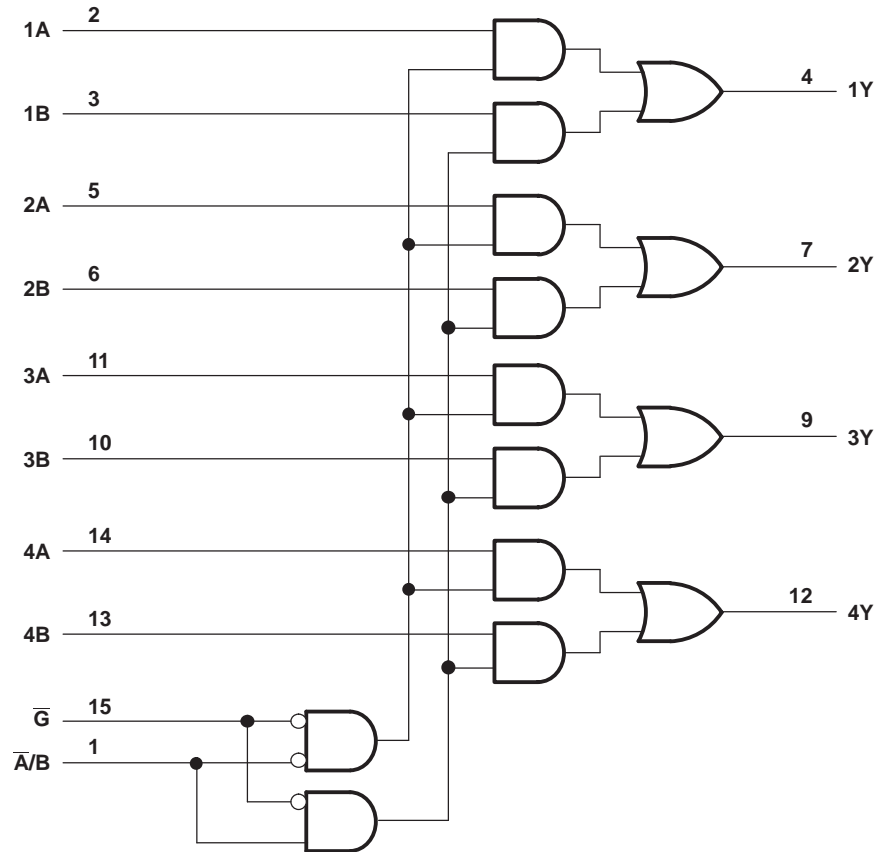

Pin numbers shown are for the D, DB, J, NS, PW, RGY, and W packages.

Absolute Maximum Ratings⁽¹⁾

over operating free-air temperature range (unless otherwise noted)

| | | MIN | MAX | UNIT |
|---|---|---------------------------------|-----------------------|---------|
| V _{CC} | Supply voltage range | -0.5 | 6.5 | V |
| V _I | Input voltage range ⁽²⁾ | -0.5 | 6.5 | V |
| V _O | Output voltage range ^{(2) (3)} | -0.5 | V _{CC} + 0.5 | V |
| I _{IK} | Input clamp current | V _I < 0 | | -50 mA |
| I _{OK} | Output clamp current | V _O < 0 | | -50 mA |
| I _O | Continuous output current | | | ±50 mA |
| Continuous current through V _{CC} or GND | | | | ±100 mA |
| θ _{JA} | Package thermal impedance | D package ⁽⁴⁾ | | 73 |
| | | DB package ⁽⁴⁾ | | 82 |
| | | NS package ⁽⁴⁾ | | 64 |
| | | PW package ⁽⁴⁾ | | 108 |
| | | RGY package ⁽⁵⁾ | | 39 |
| T _{stg} | Storage temperature range | -65 | 150 | °C |
| P _{tot} | Power dissipation ^{(6) (7)} | T _A = -40°C to 125°C | | 500 mW |

- (1) Stresses beyond those listed under "absolute maximum ratings" may cause permanent damage to the device. These are stress ratings only, and functional operation of the device at these or any other conditions beyond those indicated under "recommended operating conditions" is not implied. Exposure to absolute-maximum-rated conditions for extended periods may affect device reliability.
- (2) The input and output negative-voltage ratings may be exceeded if the input and output current ratings are observed.
- (3) The value of V_{CC} is provided in the recommended operating conditions table.
- (4) The package thermal impedance is calculated in accordance with JESD 51-7.
- (5) The package thermal impedance is calculated in accordance with JESD 51-5.
- (6) For the D package, above 70°C the value of P_{tot} derates linearly with 8 mW/K.
- (7) For the DB, NS, and PW packages, above 60°C the value of P_{tot} derates linearly with 5.5 mW/K.

Recommended Operating Conditions⁽¹⁾

| | | SN54LVC157A | | UNIT |
|-----------------|---------------------------|----------------------------------|-----------------|--------|
| | | -55 TO 125°C | | |
| | | MIN | MAX | |
| V _{CC} | Supply voltage | Operating | | 2 3.6 |
| | | Data retention only | | 1.5 |
| V _{IH} | High-level input voltage | V _{CC} = 2.7 V to 3.6 V | | 2 V |
| V _{IL} | Low-level input voltage | V _{CC} = 2.7 V to 3.6 V | | 0.8 V |
| V _I | Input voltage | 0 | 5.5 | V |
| V _O | Output voltage | 0 | V _{CC} | V |
| I _{OH} | High-level output current | V _{CC} = 2.7 V | | -12 mA |
| | | V _{CC} = 3 V | | -24 |
| I _{OL} | Low-level output current | V _{CC} = 2.7 V | | 12 mA |
| | | V _{CC} = 3 V | | 24 |

- (1) All unused inputs of the device must be held at V_{CC} or GND to ensure proper device operation. Refer to the TI application report, *Implications of Slow or Floating CMOS Inputs*, literature number SCBA004.

Recommended Operating Conditions⁽¹⁾

| | | SN74LVC157A | | | | | | UNIT | | |
|-----------------|------------------------------------|------------------------------------|-----------------|------------------------|-----------------|------------------------|-----------------|------------------------|-----------------|------|
| | | T _A = 25°C | | –40 TO 85°C | | –40 TO 125°C | | | | |
| | | MIN | MAX | MIN | MAX | MIN | MAX | | | |
| V _{CC} | Supply voltage | Operating | | 1.65 | 3.6 | 1.65 | 3.6 | 1.65 | 3.6 | V |
| | | Data retention only | | 1.5 | | 1.5 | | 1.5 | | |
| V _{IH} | High-level input voltage | V _{CC} = 1.65 V to 1.95 V | | 0.65 × V _{CC} | | 0.65 × V _{CC} | | 0.65 × V _{CC} | | V |
| | | V _{CC} = 2.3 V to 2.7 V | | 1.7 | | 1.7 | | 1.7 | | |
| | | V _{CC} = 2.7 V to 3.6 V | | 2 | | 2 | | 2 | | |
| V _{IL} | Low-level input voltage | V _{CC} = 1.65 V to 1.95 V | | 0.35 × V _{CC} | | 0.35 × V _{CC} | | 0.35 × V _{CC} | | V |
| | | V _{CC} = 2.3 V to 2.7 V | | 0.7 | | 0.7 | | 0.7 | | |
| | | V _{CC} = 2.7 V to 3.6 V | | 0.8 | | 0.8 | | 0.8 | | |
| V _I | Input voltage | 0 | 5.5 | 0 | 5.5 | 0 | 5.5 | 0 | 5.5 | V |
| V _O | Output voltage | 0 | V _{CC} | 0 | V _{CC} | 0 | V _{CC} | 0 | V _{CC} | V |
| I _{OH} | High-level output current | V _{CC} = 1.65 V | | –4 | | –4 | | –4 | | mA |
| | | V _{CC} = 2.3 V | | –8 | | –8 | | –8 | | |
| | | V _{CC} = 2.7 V | | –12 | | –12 | | –12 | | |
| | | V _{CC} = 3 V | | –24 | | –24 | | –24 | | |
| I _{OL} | Low-level output current | V _{CC} = 1.65 V | | 4 | | 4 | | 4 | | mA |
| | | V _{CC} = 2.3 V | | 8 | | 8 | | 8 | | |
| | | V _{CC} = 2.7 V | | 12 | | 12 | | 12 | | |
| | | V _{CC} = 3 V | | 24 | | 24 | | 24 | | |
| Δt/Δv | Input transition rise or fall rate | 10 | | 10 | | 10 | | 10 | | ns/V |

(1) All unused inputs of the device must be held at V_{CC} or GND to ensure proper device operation. Refer to the TI application report, *Implications of Slow or Floating CMOS Inputs*, literature number SCBA004.

Electrical Characteristics

over recommended operating free-air temperature range (unless otherwise noted)

| PARAMETER | TEST CONDITIONS | V _{CC} | SN54LVC157A | | UNIT |
|------------------|--|-------------------------------|-----------------------|--------|------|
| | | | –55 TO 125°C | | |
| | | | MIN | MAX | |
| V _{OH} | I _{OH} = –100 μA | 2.7 V to 3.6 V | V _{CC} – 0.2 | | V |
| | I _{OH} = –12 mA | 2.7 V | 2.2 | | |
| | | 3 V | 2.4 | | |
| | I _{OH} = –24 mA | 3 V | 2.2 | | |
| V _{OL} | I _{OL} = 100 μA | 2.7 V to 3.6 V | 0.2 | | V |
| | I _{OL} = 12 mA | 2.7 V | 0.4 | | |
| | I _{OL} = 24 mA | 3 V | 0.55 | | |
| I _I | All inputs | V _I = 5.5 V or GND | 3.6 V | ±5 μA | |
| I _{CC} | V _I = V _{CC} or GND | I _O = 0 | 3.6 V | 10 μA | |
| ΔI _{CC} | One input at V _{CC} – 0.6 V, Other inputs at V _{CC} or GND | | 2.7 V to 3.6 V | 500 μA | |

Electrical Characteristics

over recommended operating free-air temperature range (unless otherwise noted)

| PARAMETER | TEST CONDITIONS | V_{CC} | SN74LVC157A | | | | | | UNIT | |
|---------------------------|--|------------------------------|--------------------------|-----|-----|------------------------------------|-----|-------------------------------------|------|--------------------|
| | | | $T_A = 25^\circ\text{C}$ | | | $-40 \text{ TO } 85^\circ\text{C}$ | | $-40 \text{ TO } 125^\circ\text{C}$ | | |
| | | | MIN | TYP | MAX | MIN | MAX | MIN | | MAX |
| V_{OH} | $I_{OH} = -100 \mu\text{A}$ | 1.65 V to 3.6 V | $V_{CC} - 0.2$ | | | $V_{CC} - 0.2$ | | $V_{CC} - 0.3$ | | V |
| | $I_{OH} = -4 \text{ mA}$ | 1.65 V | 1.29 | | | 1.2 | | 1.05 | | |
| | $I_{OH} = -8 \text{ mA}$ | 2.3 V | 1.9 | | | 1.7 | | 1.55 | | |
| | $I_{OH} = -12 \text{ mA}$ | 2.7 V | 2.2 | | | 2.2 | | 2.05 | | |
| | | 3 V | 2.4 | | | 2.4 | | 2.25 | | |
| $I_{OH} = -24 \text{ mA}$ | 3 V | 2.3 | | | 2.2 | | 2 | | | |
| V_{OL} | $I_{OL} = 100 \mu\text{A}$ | 1.65 V to 3.6 V | 0.1 | | | 0.2 | | 0.3 | | V |
| | $I_{OL} = 4 \text{ mA}$ | 1.65 V | 0.24 | | | 0.45 | | 0.6 | | |
| | $I_{OL} = 8 \text{ mA}$ | 2.3 V | 0.3 | | | 0.7 | | 0.75 | | |
| | $I_{OL} = 12 \text{ mA}$ | 2.7 V | 0.4 | | | 0.4 | | 0.6 | | |
| | $I_{OL} = 24 \text{ mA}$ | 3 V | 0.55 | | | 0.55 | | 0.8 | | |
| I_I | All inputs | $V_I = 5.5 \text{ V or GND}$ | 3.6 V | | | ± 1 | | ± 5 | | μA |
| I_{CC} | $V_I = V_{CC}$ or GND | $I_O = 0$ | 3.6 V | | | 1 | | 10 | | 40 μA |
| ΔI_{CC} | One input at $V_{CC} - 0.6 \text{ V}$, Other inputs at V_{CC} or GND | | 2.7 V to 3.6 V | | | 500 | | 500 | | 5000 μA |
| C_i | $V_I = V_{CC}$ or GND | | 3.3 V | | | 5 | | | pF | |

Switching Characteristics

over recommended operating free-air temperature range (unless otherwise noted) (see [Figure 1](#))

| PARAMETER | FROM (INPUT) | TO (OUTPUT) | V_{CC} | SN54LVC157A | | UNIT |
|-----------|--------------------|----------------|-----------------------------------|-------------------------------------|-----|------|
| | | | | $-55 \text{ TO } 125^\circ\text{C}$ | | |
| | | | | MIN | MAX | |
| t_{pd} | A or B | Y | 2.7 V | 6.2 | | ns |
| | | | $3.3 \text{ V} \pm 0.3 \text{ V}$ | 0.8 | 5.4 | |
| | \bar{A}/B | | 2.7 V | 8.2 | | |
| | | | $3.3 \text{ V} \pm 0.3 \text{ V}$ | 0.8 | 7 | |
| | \bar{G} | | 2.7 V | 7.8 | | |
| | | | $3.3 \text{ V} \pm 0.3 \text{ V}$ | 0.8 | 6.5 | |

Switching Characteristics

 over recommended operating free-air temperature range (unless otherwise noted) (see [Figure 1](#))

| PARAMETER | FROM (INPUT) | TO (OUTPUT) | V _{CC} | SN74LVC157A | | | | | | UNIT | |
|--------------------|-----------------|----------------|-----------------|-----------------------|-----|------|-------------|------|--------------|------|-----|
| | | | | T _A = 25°C | | | –40 TO 85°C | | –40 TO 125°C | | |
| | | | | MIN | TYP | MAX | MIN | MAX | MIN | | MAX |
| t _{pd} | A or B | Y | 1.8 V ± 0.15 V | 1 | 5.5 | 13.5 | 1 | 14 | 1 | 15.5 | ns |
| | | | 2.5 V ± 0.2 V | 1 | 3.2 | 7.4 | 1 | 7.9 | 1 | 10 | |
| | | | 2.7 V | 1 | 3.6 | 5.7 | 1 | 5.9 | 1 | 7.4 | |
| | | | 3.3 V ± 0.3 V | 1 | 3 | 5 | 1 | 5.2 | 1 | 6.4 | |
| | A/B | | 1.8 V ± 0.15 V | 1 | 6 | 15.5 | 1 | 16 | 1 | 17.5 | |
| | | | 2.5 V ± 0.2 V | 1 | 3.7 | 9.6 | 1 | 10.1 | 1 | 12.2 | |
| | | | 2.7 V | 1 | 4.1 | 7.9 | 1 | 8.1 | 1 | 10 | |
| | | | 3.3 V ± 0.3 V | 1 | 3.4 | 6.6 | 1 | 6.8 | 1 | 8.4 | |
| | G | | 1.8 V ± 0.15 V | 1 | 5.9 | 13.5 | 1 | 14 | 1 | 15.5 | |
| | | | 2.5 V ± 0.2 V | 1 | 3.5 | 9.3 | 1 | 9.8 | 1 | 11.9 | |
| | | | 2.7 V | 1 | 3.9 | 7.6 | 1 | 7.8 | 1 | 9.3 | |
| | | | 3.3 V ± 0.3 V | 1 | 3.3 | 6.3 | 1 | 6.5 | 1 | 7.9 | |
| t _{sk(o)} | | | 1.8 V ± 0.15 V | | | | | 2 | 2.5 | ns | |
| | | | 3.3 V ± 0.3 V | | | | | 1 | 1.5 | | |

Operating Characteristics

 T_A = 25°C

| PARAMETER | | TEST CONDITIONS | V _{CC} | TYP | UNIT |
|-----------------|-------------------------------|-----------------|-----------------|-------------------|------|
| C _{pd} | Power dissipation capacitance | f = 10 MHz | 1.8 V | 14 ⁽¹⁾ | pF |
| | | | 2.5 V | 15 ⁽¹⁾ | |
| | | | 3.3 V | 16 | |

(1) On products compliant to MIL-PRF-38535, this parameter does not apply.

PARAMETER MEASUREMENT INFORMATION

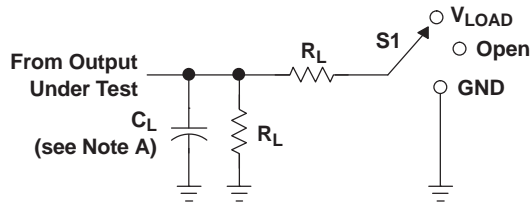

| TEST | S1 |
|-------------------|------------|
| t_{PLH}/t_{PHL} | Open |
| t_{PLZ}/t_{PZL} | V_{LOAD} |
| t_{PHZ}/t_{PZH} | GND |

LOAD CIRCUIT

| V_{CC} | INPUTS | | V_M | V_{LOAD} | C_L | R_L | V_{Δ} |
|----------------------------------|----------|----------------------|------------|-------------------|-------|--------------|--------------|
| | V_I | t_r/t_f | | | | | |
| $1.8\text{ V} \pm 0.15\text{ V}$ | V_{CC} | $\leq 2\text{ ns}$ | $V_{CC}/2$ | $2 \times V_{CC}$ | 30 pF | 1 k Ω | 0.15 V |
| $2.5\text{ V} \pm 0.2\text{ V}$ | V_{CC} | $\leq 2\text{ ns}$ | $V_{CC}/2$ | $2 \times V_{CC}$ | 30 pF | 500 Ω | 0.15 V |
| 2.7 V | 2.7 V | $\leq 2.5\text{ ns}$ | 1.5 V | 6 V | 50 pF | 500 Ω | 0.3 V |
| $3.3\text{ V} \pm 0.3\text{ V}$ | 2.7 V | $\leq 2.5\text{ ns}$ | 1.5 V | 6 V | 50 pF | 500 Ω | 0.3 V |

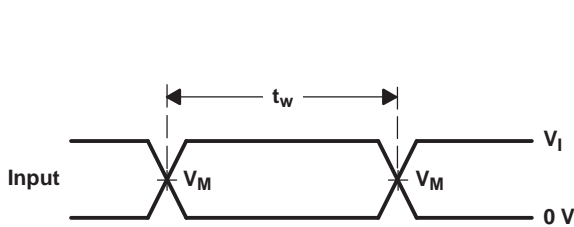

VOLTAGE WAVEFORMS PULSE DURATION

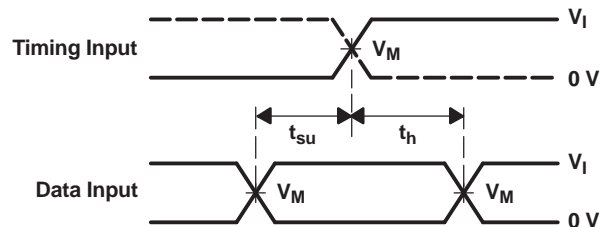

VOLTAGE WAVEFORMS SETUP AND HOLD TIMES

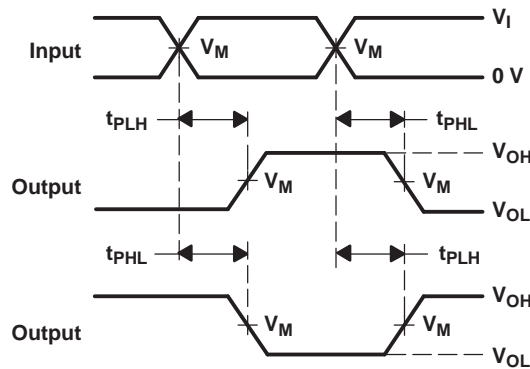

VOLTAGE WAVEFORMS PROPAGATION DELAY TIMES INVERTING AND NONINVERTING OUTPUTS

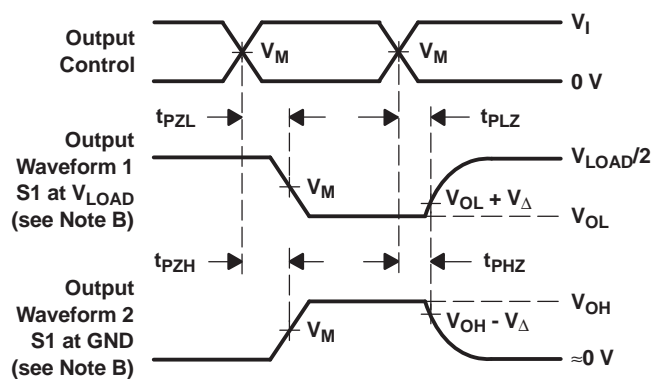

VOLTAGE WAVEFORMS ENABLE AND DISABLE TIMES LOW- AND HIGH-LEVEL ENABLING

- NOTES:
- A. C_L includes probe and jig capacitance.
 - B. Waveform 1 is for an output with internal conditions such that the output is low, except when disabled by the output control. Waveform 2 is for an output with internal conditions such that the output is high, except when disabled by the output control.
 - C. All input pulses are supplied by generators having the following characteristics: $PRR \leq 10\text{ MHz}$, $Z_O = 50\ \Omega$.
 - D. The outputs are measured one at a time, with one transition per measurement.
 - E. t_{PLZ} and t_{PHZ} are the same as t_{dis} .
 - F. t_{PZL} and t_{PZH} are the same as t_{en} .
 - G. t_{PLH} and t_{PHL} are the same as t_{pd} .
 - H. All parameters and waveforms are not applicable to all devices.

Figure 1. Load Circuit and Voltage Waveforms

PACKAGING INFORMATION

| Orderable Device | Status (1) | Package Type | Package Drawing | Pins | Package Qty | Eco Plan (2) | Lead/Ball Finish (6) | MSL Peak Temp (3) | Op Temp (°C) | Device Marking (4/5) | Samples |
|------------------|---------------|--------------|-----------------|------|-------------|----------------------------|-------------------------|----------------------|--------------|--------------------------------------|-------------------------|
| 5962-0050601QEA | ACTIVE | CDIP | J | 16 | 1 | TBD | A42 | N / A for Pkg Type | -55 to 125 | 5962-0050601QE A SNJ54LVC157AJ | Samples |
| 5962-0050601QFA | ACTIVE | CFP | W | 16 | 1 | TBD | A42 | N / A for Pkg Type | -55 to 125 | 5962-0050601QF A SNJ54LVC157AW | Samples |
| SN74LVC157AD | ACTIVE | SOIC | D | 16 | 40 | Green (RoHS & no Sb/Br) | CU NIPDAU | Level-1-260C-UNLIM | -40 to 125 | LVC157A | Samples |
| SN74LVC157ADBR | ACTIVE | SSOP | DB | 16 | 2000 | Green (RoHS & no Sb/Br) | CU NIPDAU | Level-1-260C-UNLIM | -40 to 125 | LC157A | Samples |
| SN74LVC157ADE4 | ACTIVE | SOIC | D | 16 | 40 | Green (RoHS & no Sb/Br) | CU NIPDAU | Level-1-260C-UNLIM | -40 to 125 | LVC157A | Samples |
| SN74LVC157ADG4 | ACTIVE | SOIC | D | 16 | 40 | Green (RoHS & no Sb/Br) | CU NIPDAU | Level-1-260C-UNLIM | -40 to 125 | LVC157A | Samples |
| SN74LVC157ADR | ACTIVE | SOIC | D | 16 | 2500 | Green (RoHS & no Sb/Br) | CU NIPDAU CU SN | Level-1-260C-UNLIM | -40 to 125 | LVC157A | Samples |
| SN74LVC157ADRE4 | ACTIVE | SOIC | D | 16 | 2500 | Green (RoHS & no Sb/Br) | CU NIPDAU | Level-1-260C-UNLIM | -40 to 125 | LVC157A | Samples |
| SN74LVC157ADRG3 | ACTIVE | SOIC | D | 16 | 2500 | Green (RoHS & no Sb/Br) | CU SN | Level-1-260C-UNLIM | -40 to 125 | LVC157A | Samples |
| SN74LVC157ADRG4 | ACTIVE | SOIC | D | 16 | 2500 | Green (RoHS & no Sb/Br) | CU NIPDAU | Level-1-260C-UNLIM | -40 to 125 | LVC157A | Samples |
| SN74LVC157ADT | ACTIVE | SOIC | D | 16 | 250 | Green (RoHS & no Sb/Br) | CU NIPDAU | Level-1-260C-UNLIM | -40 to 125 | LVC157A | Samples |
| SN74LVC157ANSR | ACTIVE | SO | NS | 16 | 2000 | Green (RoHS & no Sb/Br) | CU NIPDAU | Level-1-260C-UNLIM | -40 to 125 | LVC157A | Samples |
| SN74LVC157ANSRE4 | ACTIVE | SO | NS | 16 | 2000 | Green (RoHS & no Sb/Br) | CU NIPDAU | Level-1-260C-UNLIM | -40 to 125 | LVC157A | Samples |
| SN74LVC157APW | ACTIVE | TSSOP | PW | 16 | 90 | Green (RoHS & no Sb/Br) | CU NIPDAU | Level-1-260C-UNLIM | -40 to 125 | LC157A | Samples |
| SN74LVC157APWE4 | ACTIVE | TSSOP | PW | 16 | 90 | Green (RoHS & no Sb/Br) | CU NIPDAU | Level-1-260C-UNLIM | -40 to 125 | LC157A | Samples |
| SN74LVC157APWG4 | ACTIVE | TSSOP | PW | 16 | 90 | Green (RoHS & no Sb/Br) | CU NIPDAU | Level-1-260C-UNLIM | -40 to 125 | LC157A | Samples |

| Orderable Device | Status (1) | Package Type | Package Drawing | Pins | Package Qty | Eco Plan (2) | Lead/Ball Finish (6) | MSL Peak Temp (3) | Op Temp (°C) | Device Marking (4/5) | Samples |
|-------------------|---------------|--------------|-----------------|------|-------------|-------------------------|-------------------------|----------------------|--------------|--------------------------------------|-------------------------|
| SN74LVC157APWR | ACTIVE | TSSOP | PW | 16 | 2000 | Green (RoHS & no Sb/Br) | CU NIPDAU CU SN | Level-1-260C-UNLIM | -40 to 125 | LC157A | Samples |
| SN74LVC157APWRE4 | ACTIVE | TSSOP | PW | 16 | 2000 | Green (RoHS & no Sb/Br) | CU NIPDAU | Level-1-260C-UNLIM | -40 to 125 | LC157A | Samples |
| SN74LVC157APWRG4 | ACTIVE | TSSOP | PW | 16 | 2000 | Green (RoHS & no Sb/Br) | CU NIPDAU | Level-1-260C-UNLIM | -40 to 125 | LC157A | Samples |
| SN74LVC157APWT | ACTIVE | TSSOP | PW | 16 | 250 | Green (RoHS & no Sb/Br) | CU NIPDAU | Level-1-260C-UNLIM | -40 to 125 | LC157A | Samples |
| SN74LVC157ARGYR | ACTIVE | VQFN | RGY | 16 | 3000 | Green (RoHS & no Sb/Br) | CU NIPDAU | Level-2-260C-1 YEAR | -40 to 85 | LC157A | Samples |
| SN74LVC157ARGYRG4 | ACTIVE | VQFN | RGY | 16 | 3000 | Green (RoHS & no Sb/Br) | CU NIPDAU | Level-2-260C-1 YEAR | -40 to 85 | LC157A | Samples |
| SNJ54LVC157AJ | ACTIVE | CDIP | J | 16 | 1 | TBD | A42 | N / A for Pkg Type | -55 to 125 | 5962-0050601QE A SNJ54LVC157AJ | Samples |
| SNJ54LVC157AW | ACTIVE | CFP | W | 16 | 1 | TBD | A42 | N / A for Pkg Type | -55 to 125 | 5962-0050601QF A SNJ54LVC157AW | Samples |

(1) The marketing status values are defined as follows:

ACTIVE: Product device recommended for new designs.

LIFEBUY: TI has announced that the device will be discontinued, and a lifetime-buy period is in effect.

NRND: Not recommended for new designs. Device is in production to support existing customers, but TI does not recommend using this part in a new design.

PREVIEW: Device has been announced but is not in production. Samples may or may not be available.

OBSELETE: TI has discontinued the production of the device.

(2) **RoHS:** TI defines "RoHS" to mean semiconductor products that are compliant with the current EU RoHS requirements for all 10 RoHS substances, including the requirement that RoHS substance do not exceed 0.1% by weight in homogeneous materials. Where designed to be soldered at high temperatures, "RoHS" products are suitable for use in specified lead-free processes. TI may reference these types of products as "Pb-Free".

RoHS Exempt: TI defines "RoHS Exempt" to mean products that contain lead but are compliant with EU RoHS pursuant to a specific EU RoHS exemption.

Green: TI defines "Green" to mean the content of Chlorine (Cl) and Bromine (Br) based flame retardants meet JS709B low halogen requirements of <=1000ppm threshold. Antimony trioxide based flame retardants must also meet the <=1000ppm threshold requirement.

(3) MSL, Peak Temp. - The Moisture Sensitivity Level rating according to the JEDEC industry standard classifications, and peak solder temperature.

(4) There may be additional marking, which relates to the logo, the lot trace code information, or the environmental category on the device.

(5) Multiple Device Markings will be inside parentheses. Only one Device Marking contained in parentheses and separated by a "--" will appear on a device. If a line is indented then it is a continuation of the previous line and the two combined represent the entire Device Marking for that device.

(6) Lead/Ball Finish - Orderable Devices may have multiple material finish options. Finish options are separated by a vertical ruled line. Lead/Ball Finish values may wrap to two lines if the finish value exceeds the maximum column width.

Important Information and Disclaimer:The information provided on this page represents TI's knowledge and belief as of the date that it is provided. TI bases its knowledge and belief on information provided by third parties, and makes no representation or warranty as to the accuracy of such information. Efforts are underway to better integrate information from third parties. TI has taken and continues to take reasonable steps to provide representative and accurate information but may not have conducted destructive testing or chemical analysis on incoming materials and chemicals. TI and TI suppliers consider certain information to be proprietary, and thus CAS numbers and other limited information may not be available for release.

In no event shall TI's liability arising out of such information exceed the total purchase price of the TI part(s) at issue in this document sold by TI to Customer on an annual basis.

OTHER QUALIFIED VERSIONS OF SN54LVC157A, SN74LVC157A :

- Catalog: [SN74LVC157A](#)

- Automotive: [SN74LVC157A-Q1](#), [SN74LVC157A-Q1](#)

- Enhanced Product: [SN74LVC157A-EP](#), [SN74LVC157A-EP](#)

- Military: [SN54LVC157A](#)

NOTE: Qualified Version Definitions:

- Catalog - TI's standard catalog product

- Automotive - Q100 devices qualified for high-reliability automotive applications targeting zero defects

- Enhanced Product - Supports Defense, Aerospace and Medical Applications

- Military - QML certified for Military and Defense Applications

TAPE AND REEL INFORMATION

QUADRANT ASSIGNMENTS FOR PIN 1 ORIENTATION IN TAPE

*All dimensions are nominal

| Device | Package Type | Package Drawing | Pins | SPQ | Reel Diameter (mm) | Reel Width W1 (mm) | A0 (mm) | B0 (mm) | K0 (mm) | P1 (mm) | W (mm) | Pin1 Quadrant |
|------------------|--------------|-----------------|------|------|--------------------|--------------------|---------|---------|---------|---------|--------|---------------|
| SN74LVC157ADR | SOIC | D | 16 | 2500 | 330.0 | 16.8 | 6.5 | 10.3 | 2.1 | 8.0 | 16.0 | Q1 |
| SN74LVC157ADR | SOIC | D | 16 | 2500 | 330.0 | 16.4 | 6.5 | 10.3 | 2.1 | 8.0 | 16.0 | Q1 |
| SN74LVC157ADRG3 | SOIC | D | 16 | 2500 | 330.0 | 16.8 | 6.5 | 10.3 | 2.1 | 8.0 | 16.0 | Q1 |
| SN74LVC157ADRG4 | SOIC | D | 16 | 2500 | 330.0 | 16.4 | 6.5 | 10.3 | 2.1 | 8.0 | 16.0 | Q1 |
| SN74LVC157ANSR | SO | NS | 16 | 2000 | 330.0 | 16.4 | 8.2 | 10.5 | 2.5 | 12.0 | 16.0 | Q1 |
| SN74LVC157APWR | TSSOP | PW | 16 | 2000 | 330.0 | 12.4 | 6.9 | 5.6 | 1.6 | 8.0 | 12.0 | Q1 |
| SN74LVC157APWR | TSSOP | PW | 16 | 2000 | 330.0 | 12.4 | 6.9 | 5.6 | 1.6 | 8.0 | 12.0 | Q1 |
| SN74LVC157APWRG4 | TSSOP | PW | 16 | 2000 | 330.0 | 12.4 | 6.9 | 5.6 | 1.6 | 8.0 | 12.0 | Q1 |
| SN74LVC157APWT | TSSOP | PW | 16 | 250 | 330.0 | 12.4 | 6.9 | 5.6 | 1.6 | 8.0 | 12.0 | Q1 |
| SN74LVC157ARGYR | VQFN | RGY | 16 | 3000 | 330.0 | 12.4 | 3.8 | 4.3 | 1.5 | 8.0 | 12.0 | Q1 |

TAPE AND REEL BOX DIMENSIONS

*All dimensions are nominal

| Device | Package Type | Package Drawing | Pins | SPQ | Length (mm) | Width (mm) | Height (mm) |
|------------------|--------------|-----------------|------|------|-------------|------------|-------------|
| SN74LVC157ADR | SOIC | D | 16 | 2500 | 364.0 | 364.0 | 27.0 |
| SN74LVC157ADR | SOIC | D | 16 | 2500 | 333.2 | 345.9 | 28.6 |
| SN74LVC157ADRG3 | SOIC | D | 16 | 2500 | 364.0 | 364.0 | 27.0 |
| SN74LVC157ADRG4 | SOIC | D | 16 | 2500 | 333.2 | 345.9 | 28.6 |
| SN74LVC157ANSR | SO | NS | 16 | 2000 | 367.0 | 367.0 | 38.0 |
| SN74LVC157APWR | TSSOP | PW | 16 | 2000 | 364.0 | 364.0 | 27.0 |
| SN74LVC157APWR | TSSOP | PW | 16 | 2000 | 367.0 | 367.0 | 35.0 |
| SN74LVC157APWRG4 | TSSOP | PW | 16 | 2000 | 367.0 | 367.0 | 35.0 |
| SN74LVC157APWT | TSSOP | PW | 16 | 250 | 367.0 | 367.0 | 35.0 |
| SN74LVC157ARGYR | VQFN | RGY | 16 | 3000 | 367.0 | 367.0 | 35.0 |

D (R-PDSO-G16)

PLASTIC SMALL OUTLINE



- NOTES:
- A. All linear dimensions are in inches (millimeters).
 - B. This drawing is subject to change without notice.
 - C. Body length does not include mold flash, protrusions, or gate burrs. Mold flash, protrusions, or gate burrs shall not exceed 0.006 (0,15) each side.
 - D. Body width does not include interlead flash. Interlead flash shall not exceed 0.017 (0,43) each side.
 - E. Reference JEDEC MS-012 variation AC.

D (R-PDSO-G16)

PLASTIC SMALL OUTLINE



- NOTES:
- All linear dimensions are in millimeters.
 - This drawing is subject to change without notice.
 - Publication IPC-7351 is recommended for alternate designs.
 - Laser cutting apertures with trapezoidal walls and also rounding corners will offer better paste release. Customers should contact their board assembly site for stencil design recommendations. Refer to IPC-7525 for other stencil recommendations.
 - Customers should contact their board fabrication site for solder mask tolerances between and around signal pads.



4220204/A 02/2017

NOTES:

1. All linear dimensions are in millimeters. Any dimensions in parenthesis are for reference only. Dimensioning and tolerancing per ASME Y14.5M.
2. This drawing is subject to change without notice.
3. This dimension does not include mold flash, protrusions, or gate burrs. Mold flash, protrusions, or gate burrs shall not exceed 0.15 mm per side.
4. This dimension does not include interlead flash. Interlead flash shall not exceed 0.25 mm per side.
5. Reference JEDEC registration MO-153.

EXAMPLE BOARD LAYOUT

PW0016A

TSSOP - 1.2 mm max height

SMALL OUTLINE PACKAGE



LAND PATTERN EXAMPLE
EXPOSED METAL SHOWN
SCALE: 10X



SOLDER MASK DETAILS

4220204/A 02/2017

NOTES: (continued)

- 6. Publication IPC-7351 may have alternate designs.
- 7. Solder mask tolerances between and around signal pads can vary based on board fabrication site.

EXAMPLE STENCIL DESIGN

PW0016A

TSSOP - 1.2 mm max height

SMALL OUTLINE PACKAGE



SOLDER PASTE EXAMPLE
BASED ON 0.125 mm THICK STENCIL
SCALE: 10X

4220204/A 02/2017

NOTES: (continued)

8. Laser cutting apertures with trapezoidal walls and rounded corners may offer better paste release. IPC-7525 may have alternate design recommendations.
9. Board assembly site may have different recommendations for stencil design.

MECHANICAL DATA

NS (R-PDSO-G**)

PLASTIC SMALL-OUTLINE PACKAGE

14-PINS SHOWN



- NOTES:
- A. All linear dimensions are in millimeters.
 - B. This drawing is subject to change without notice.
 - C. Body dimensions do not include mold flash or protrusion, not to exceed 0,15.

W (R-GDFP-F16)

CERAMIC DUAL FLATPACK

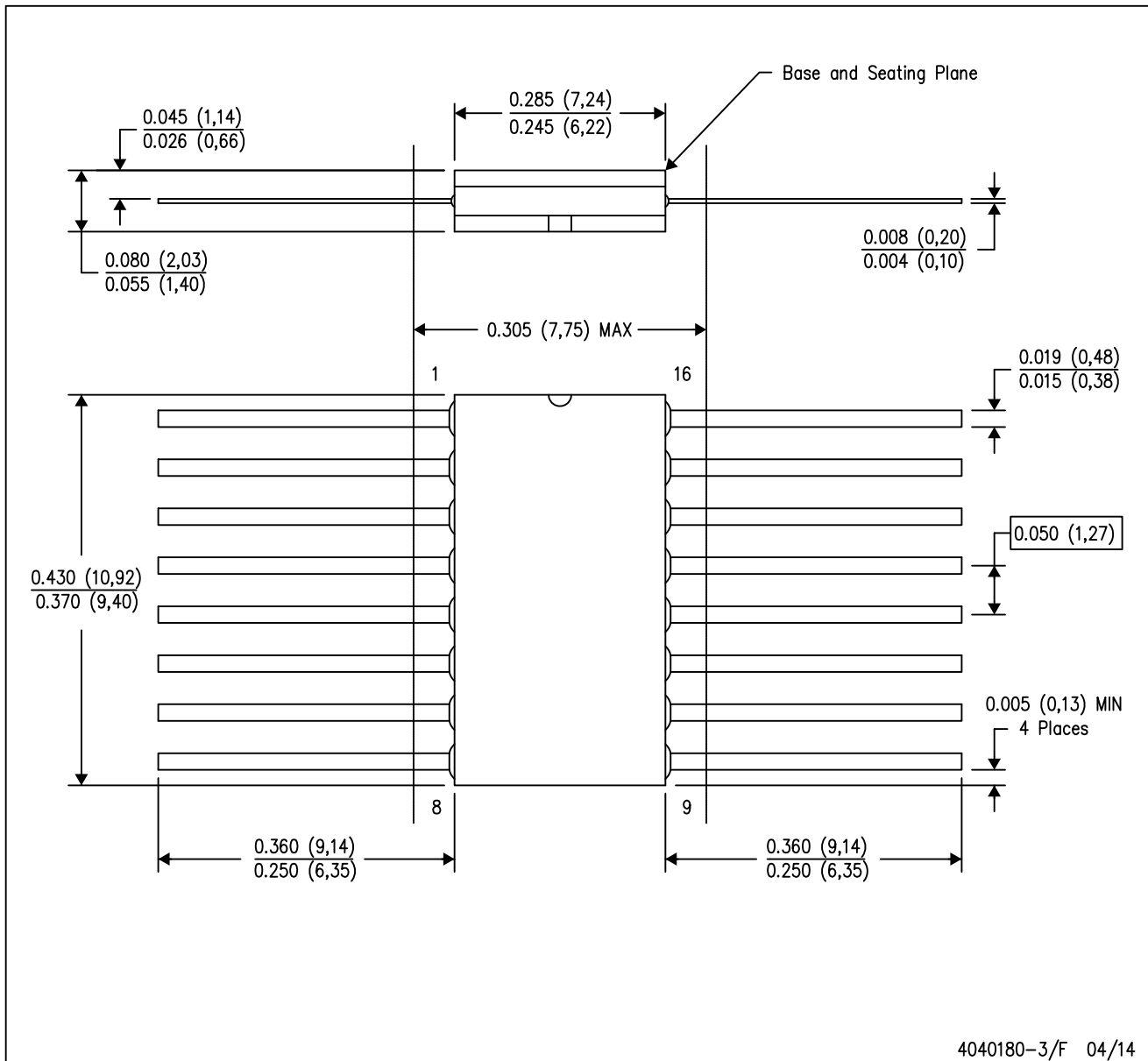

- NOTES:
- A. All linear dimensions are in inches (millimeters).
 - B. This drawing is subject to change without notice.
 - C. This package can be hermetically sealed with a ceramic lid using glass frit.
 - D. Index point is provided on cap for terminal identification only.
 - E. Falls within MIL STD 1835 GDFP2-F16

J (R-GDIP-T**)

14 LEADS SHOWN

CERAMIC DUAL IN-LINE PACKAGE



| DIM \ PINS ** | 14 | 16 | 18 | 20 |
|---------------|------------------------|------------------------|------------------------|------------------------|
| A | 0.300 (7,62) BSC | 0.300 (7,62) BSC | 0.300 (7,62) BSC | 0.300 (7,62) BSC |
| B MAX | 0.785 (19,94) | .840 (21,34) | 0.960 (24,38) | 1.060 (26,92) |
| B MIN | — | — | — | — |
| C MAX | 0.300 (7,62) | 0.300 (7,62) | 0.310 (7,87) | 0.300 (7,62) |
| C MIN | 0.245 (6,22) | 0.245 (6,22) | 0.220 (5,59) | 0.245 (6,22) |



4040083/F 03/03

- NOTES:
- All linear dimensions are in inches (millimeters).
 - This drawing is subject to change without notice.
 - This package is hermetically sealed with a ceramic lid using glass frit.
 - Index point is provided on cap for terminal identification only on press ceramic glass frit seal only.
 - Falls within MIL STD 1835 GDIP1-T14, GDIP1-T16, GDIP1-T18 and GDIP1-T20.

DB (R-PDSO-G**)

PLASTIC SMALL-OUTLINE

28 PINS SHOWN



- NOTES: A. All linear dimensions are in millimeters.
 B. This drawing is subject to change without notice.
 C. Body dimensions do not include mold flash or protrusion not to exceed 0,15.
 D. Falls within JEDEC MO-150

RGY (R-PVQFN-N16)

PLASTIC QUAD FLATPACK NO-LEAD



4203539-3/1 06/2011

- NOTES:
- All linear dimensions are in millimeters. Dimensioning and tolerancing per ASME Y14.5M-1994.
 - This drawing is subject to change without notice.
 - QFN (Quad Flatpack No-Lead) package configuration.
 - The package thermal pad must be soldered to the board for thermal and mechanical performance.
 - See the additional figure in the Product Data Sheet for details regarding the exposed thermal pad features and dimensions.
 - Pin 1 identifiers are located on both top and bottom of the package and within the zone indicated. The Pin 1 identifiers are either a molded, marked, or metal feature.
 - Package complies to JEDEC MO-241 variation BA.

RGY (R-PVQFN-N16)

PLASTIC QUAD FLATPACK NO-LEAD

THERMAL INFORMATION

This package incorporates an exposed thermal pad that is designed to be attached directly to an external heatsink. The thermal pad must be soldered directly to the printed circuit board (PCB). After soldering, the PCB can be used as a heatsink. In addition, through the use of thermal vias, the thermal pad can be attached directly to the appropriate copper plane shown in the electrical schematic for the device, or alternatively, can be attached to a special heatsink structure designed into the PCB. This design optimizes the heat transfer from the integrated circuit (IC).

For information on the Quad Flatpack No-Lead (QFN) package and its advantages, refer to Application Report, QFN/SON PCB Attachment, Texas Instruments Literature No. SLUA271. This document is available at www.ti.com.

The exposed thermal pad dimensions for this package are shown in the following illustration.



Bottom View

Exposed Thermal Pad Dimensions

4206353-3/P 03/14

NOTE: All linear dimensions are in millimeters

RGY (R-PVQFN-N16)

PLASTIC QUAD FLATPACK NO-LEAD



4208122-3/P 03/14

- NOTES:
- A. All linear dimensions are in millimeters.
 - B. This drawing is subject to change without notice.
 - C. Publication IPC-7351 is recommended for alternate designs.
 - D. This package is designed to be soldered to a thermal pad on the board. Refer to Application Note, Quad Flat-Pack QFN/SON PCB Attachment, Texas Instruments Literature No. SLUA271, and also the Product Data Sheets for specific thermal information, via requirements, and recommended board layout. These documents are available at www.ti.com <<http://www.ti.com>>.
 - E. Laser cutting apertures with trapezoidal walls and also rounding corners will offer better paste release. Customers should contact their board assembly site for stencil design recommendations. Refer to IPC 7525 for stencil design considerations.
 - F. Customers should contact their board fabrication site for minimum solder mask web tolerances between signal pads.

IMPORTANT NOTICE AND DISCLAIMER

TI PROVIDES TECHNICAL AND RELIABILITY DATA (INCLUDING DATASHEETS), DESIGN RESOURCES (INCLUDING REFERENCE DESIGNS), APPLICATION OR OTHER DESIGN ADVICE, WEB TOOLS, SAFETY INFORMATION, AND OTHER RESOURCES "AS IS" AND WITH ALL FAULTS, AND DISCLAIMS ALL WARRANTIES, EXPRESS AND IMPLIED, INCLUDING WITHOUT LIMITATION ANY IMPLIED WARRANTIES OF MERCHANTABILITY, FITNESS FOR A PARTICULAR PURPOSE OR NON-INFRINGEMENT OF THIRD PARTY INTELLECTUAL PROPERTY RIGHTS.

These resources are intended for skilled developers designing with TI products. You are solely responsible for (1) selecting the appropriate TI products for your application, (2) designing, validating and testing your application, and (3) ensuring your application meets applicable standards, and any other safety, security, or other requirements. These resources are subject to change without notice. TI grants you permission to use these resources only for development of an application that uses the TI products described in the resource. Other reproduction and display of these resources is prohibited. No license is granted to any other TI intellectual property right or to any third party intellectual property right. TI disclaims responsibility for, and you will fully indemnify TI and its representatives against, any claims, damages, costs, losses, and liabilities arising out of your use of these resources.

TI's products are provided subject to TI's Terms of Sale (www.ti.com/legal/termsofsale.html) or other applicable terms available either on ti.com or provided in conjunction with such TI products. TI's provision of these resources does not expand or otherwise alter TI's applicable warranties or warranty disclaimers for TI products.

Mailing Address: Texas Instruments, Post Office Box 655303, Dallas, Texas 75265
Copyright © 2019, Texas Instruments Incorporated

Looking for pricing, stock, or lifecycle information?

Click below to explore more details on WIN SOURCE:

 [View SN74LVC157APWG4 on WIN SOURCE](#)

 [Texas Instruments](#) Information

Optimize Your Supply Chain with WIN SOURCE Solutions

-  Global Sourcing Solution
-  Obsolete Management
-  Cost Control Management
-  Shortage Management
-  Alternative Solution
-  Excess Inventory Management