



# THE DATASHEET OF TSH80IDT





# TSH80, TSH81, TSH82, TSH84

## Wide band rail-to-rail operational amplifier with standby function

Datasheet – production data

### Features

- Operating range from 4.5 to 12 V
- 3 dB-bandwidth: 100 MHz
- Slew rate 100 V/ $\mu$ s
- Output current up to 55 mA
- Input single supply voltage
- Output rail-to-rail
- Specified for 150  $\Omega$  loads
- Low distortion, THD 0.1%
- SOT23-5, SO, and TSSOP packages

### Applications

- Video buffers
- A/D converter drivers
- Hi-fi applications

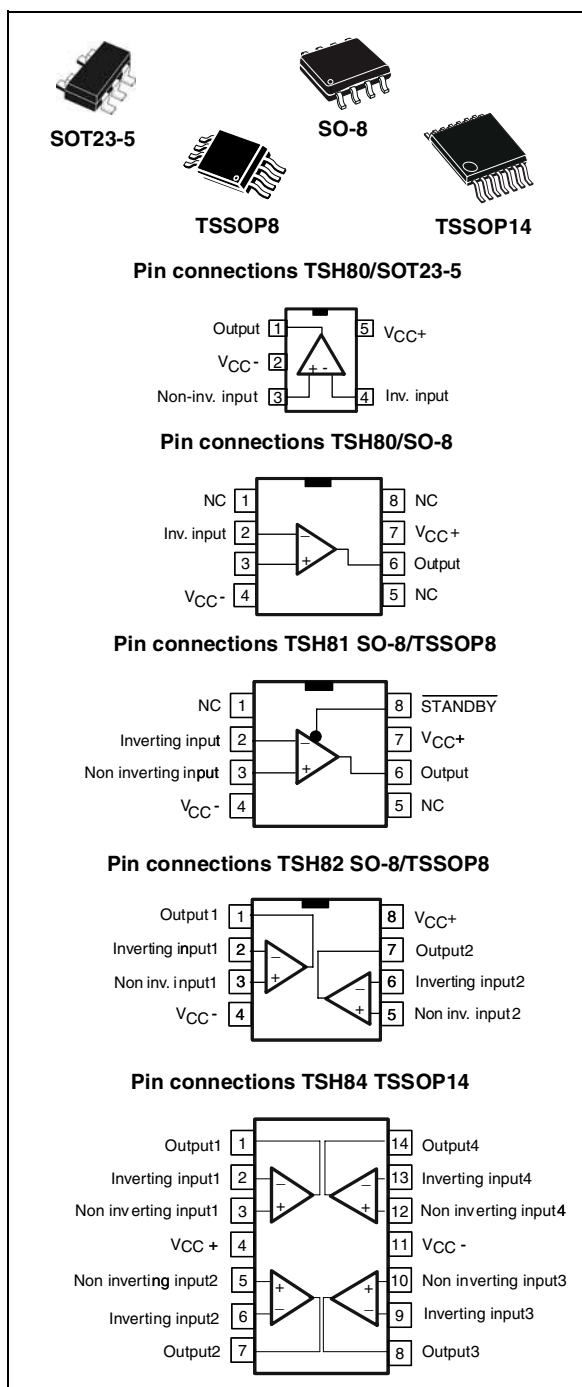
### Description

The TSH8x series offers single, dual and quad operational amplifiers featuring high video performance with large bandwidth, low distortion and excellent supply voltage rejection. These amplifiers also feature large output voltage swings and a high output current capability to drive standard 150  $\Omega$  loads.

Running at single or dual supply voltages ranging from 4.5 to 12 V, these amplifiers are tested at 5 V ( $\pm 2.5$  V) and 10 V ( $\pm 5$  V) supplies.

The TSH81 device also features a standby mode, which provides the operational amplifier with a low power consumption and high output impedance. This function allows power saving or signal switching/multiplexing for high-speed and video applications.

For board space and weight saving, the TSH8x series is proposed in SOT23-5, SO-8, TSSOP8, and TSSOP14 plastic micropackages.



---

# Contents

<b>1</b>	<b>Absolute maximum ratings and operating conditions</b>	<b>5</b>
<b>2</b>	<b>Electrical characteristics</b>	<b>6</b>
<b>3</b>	<b>Test conditions</b>	<b>18</b>
3.1	Layout precautions	18
3.2	Video capabilities	19
<b>4</b>	<b>Precautions on asymmetrical supply operation</b>	<b>21</b>
<b>5</b>	<b>Package information</b>	<b>22</b>
5.1	SOT23-5 package information	23
5.2	SO-8 package information	24
5.3	TSSOP8 package information	25
5.4	TSSOP14 package information	26
<b>6</b>	<b>Ordering information</b>	<b>27</b>
<b>7</b>	<b>Revision history</b>	<b>28</b>

## List of tables

Table 1.	Absolute maximum ratings . . . . .	5
Table 2.	Operating conditions . . . . .	5
Table 3.	$V_{CC+} = +5\text{ V}$ , $V_{CC-} = \text{GND}$ , $V_{ic} = 2.5\text{ V}$ , $T_{amb} = 25\text{ °C}$ (unless otherwise specified) . . . . .	6
Table 4.	$V_{CC+} = +5\text{ V}$ , $V_{CC-} = -5\text{ V}$ , $V_{ic} = \text{GND}$ , $T_{amb} = 25\text{ °C}$ (unless otherwise specified) . . . . .	9
Table 5.	Standby mode - $V_{CC+}$ , $V_{CC-}$ , $T_{amb} = 25\text{ °C}$ (unless otherwise specified) . . . . .	11
Table 6.	TSH81 standby control pin status . . . . .	11
Table 7.	Video results . . . . .	20
Table 8.	SOT23-5 package mechanical data . . . . .	23
Table 9.	SO-8 package mechanical data . . . . .	24
Table 10.	TSSOP8 package mechanical data . . . . .	25
Table 11.	TSSOP14 package mechanical data . . . . .	26
Table 12.	Order codes . . . . .	27
Table 13.	Document revision history . . . . .	28

## List of figures

Figure 1.	Closed loop gain and phase vs. frequency (gain = +2, $V_{CC} = \pm 2.5\text{ V}$ )	12
Figure 2.	Overshoot vs. output capacitance ( $V_{CC} = \pm 2.5\text{ V}$ )	12
Figure 3.	Closed loop gain and phase vs. frequency (gain = -10, $V_{CC} = \pm 2.5\text{ V}$ )	12
Figure 4.	Closed loop gain and phase vs. frequency (gain = +11, $V_{CC} = \pm 2.5\text{ V}$ )	12
Figure 5.	Large signal measurement – positive slew rate ( $V_{CC} = \pm 2.5\text{ V}$ )	12
Figure 6.	Large signal measurement – negative slew rate ( $V_{CC} = \pm 2.5\text{ V}$ )	12
Figure 7.	Small signal measurement – rise time ( $V_{CC} = \pm 2.5\text{ V}$ )	13
Figure 8.	Small signal measurement – fall time ( $V_{CC} = \pm 2.5\text{ V}$ )	13
Figure 9.	Channel separation (crosstalk) vs. frequency schematic ( $V_{CC} = \pm 2.5\text{ V}$ )	13
Figure 10.	Channel separation (crosstalk) vs. frequency ( $V_{CC} = \pm 2.5\text{ V}$ )	13
Figure 11.	Equivalent input noise voltage ( $V_{CC} = \pm 2.5\text{ V}$ )	13
Figure 12.	Maximum output swing ( $V_{CC} = \pm 2.5\text{ V}$ )	13
Figure 13.	Standby mode - $T_{on}$ , $T_{off}$ ( $V_{CC} = \pm 2.5\text{ V}$ )	14
Figure 14.	Third order intermodulation ( $V_{CC} = \pm 2.5\text{ V}$ )	14
Figure 15.	Group delay ( $V_{CC} = \pm 2.5\text{ V}$ )	14
Figure 16.	Closed loop gain and phase vs. frequency (gain = +2, $V_{CC} = \pm 5\text{ V}$ )	15
Figure 17.	Overshoot vs. output capacitance ( $V_{CC} = \pm 5\text{ V}$ )	15
Figure 18.	Closed loop gain and phase vs. frequency (gain = -10, $V_{CC} = \pm 5\text{ V}$ )	15
Figure 19.	Closed loop gain and phase vs. frequency (gain = +11, $V_{CC} = \pm 5\text{ V}$ )	15
Figure 20.	Large signal measurement - positive slew rate ( $V_{CC} = \pm 5\text{ V}$ )	15
Figure 21.	Large signal measurement - negative slew rate ( $V_{CC} = \pm 5\text{ V}$ )	15
Figure 22.	Small signal measurement – rise time ( $V_{CC} = \pm 5\text{ V}$ )	16
Figure 23.	Small signal measurement – fall time ( $V_{CC} = \pm 5\text{ V}$ )	16
Figure 24.	Channel separation (crosstalk) vs. frequency schematic ( $V_{CC} = \pm 5\text{ V}$ )	16
Figure 25.	Channel separation (crosstalk) vs. frequency ( $V_{CC} = \pm 5\text{ V}$ )	16
Figure 26.	Equivalent input noise voltage ( $V_{CC} = \pm 5\text{ V}$ )	16
Figure 27.	Maximum output swing ( $V_{CC} = \pm 5\text{ V}$ )	16
Figure 28.	Standby mode - $T_{on}$ , $T_{off}$ ( $V_{CC} = \pm 5\text{ V}$ )	17
Figure 29.	Third order intermodulation ( $V_{CC} = \pm 5\text{ V}$ )	17
Figure 30.	Group delay $V_{CC} = \pm 5\text{ V}$	17
Figure 31.	CCIR330 video line	18
Figure 32.	Measurement on Rohde and Schwarz VSA	19
Figure 33.	Asymmetrical supply schematic diagram	21
Figure 34.	Use of the TSH8x in a gain = -1 configuration	21
Figure 35.	SOT23-5 package outline	23
Figure 36.	SO-8 package outline	24
Figure 37.	TSSOP8 package outline	25
Figure 38.	TSSOP14 package outline	26

# 1 Absolute maximum ratings and operating conditions

**Table 1. Absolute maximum ratings**

Symbol	Parameter	Value	Unit
$V_{CC}$	Supply voltage <sup>(1)</sup>	14	V
$V_{id}$	Differential input voltage <sup>(2)</sup>	$\pm 2$	V
$V_i$	Input voltage <sup>(3)</sup>	$\pm 6$	V
$T_{oper}$	Operating free air temperature range	-40 to +85	°C
$T_{stg}$	Storage temperature	-65 to +150	°C
$T_j$	Maximum junction temperature	150	°C
$R_{thjc}$	Thermal resistance junction to case <sup>(4)</sup>		
	SOT23-5	80	°C/W
	SO8	28	
	TSSOP8	37	
TSSOP14	32		
$R_{thja}$	Thermal resistance junction to ambient area		
	SOT23-5	250	°C/W
	SO8	157	
	TSSOP8	130	
TSSOP14	110		
ESD	HBM: human body model <sup>(5)</sup>	2	kV
	MM: machine model <sup>(6)</sup>	0.2	
	CDM: charged device model <sup>(7)</sup>	1	

- All voltage values, except differential voltage are with respect to network ground terminal.
- Differential voltages are the non inverting input terminal with respect to the inverting terminal.
- The magnitude of input and output must never exceed  $V_{CC} + 0.3$  V.
- Short-circuits can cause excessive heating.
- Human body model: a 100 pF capacitor is charged to the specified voltage, then discharged through a 1.5 k $\Omega$  resistor between two pins of the device. This is done for all couples of connected pin combinations while the other pins are floating.
- Machine model: a 200 pF capacitor is charged to the specified voltage, then discharged directly between two pins of the device with no external series resistor (internal resistor < 5  $\Omega$ ). This is done for all couples of connected pin combinations while the other pins are floating.
- Charged device model: all pins and package are charged together to the specified voltage and then discharged directly to the ground through only one pin. This is done for all pins.

**Table 2. Operating conditions**

Symbol	Parameter	Value	Unit
$V_{CC}$	Supply voltage	4.5 to 12	V
$V_{IC}$	Common mode input voltage range	$V_{CC}^-$ to $(V_{CC}^+ - 1.1)$	V
Standby (pin 8)	Threshold on pin 8 for TSH81	$(V_{CC}^-)$ to $(V_{CC}^+)$	V

## 2 Electrical characteristics

**Table 3.**  $V_{CC}^+ = +5\text{ V}$ ,  $V_{CC}^- = \text{GND}$ ,  $V_{ic} = 2.5\text{ V}$ ,  $T_{amb} = 25\text{ °C}$   
(unless otherwise specified)

Symbol	Parameter	Test conditions	Min.	Typ.	Max.	Unit
$ V_{io} $	Input offset voltage	$T_{amb} = 25\text{ °C}$ $T_{min} < T_{amb} < T_{max}$		1.1	10 12	mV
$\Delta V_{io}$	Input offset voltage drift vs. temperature	$T_{min} < T_{amb} < T_{max}$		3		$\mu\text{V}/\text{°C}$
$I_{io}$	Input offset current	$T_{amb} = 25\text{ °C}$ $T_{min} < T_{amb} < T_{max}$		0.1	3.5 5	$\mu\text{A}$
$I_{ib}$	Input bias current	$T_{amb} = 25\text{ °C}$ $T_{min} < T_{amb} < T_{max}$		6	15 20	$\mu\text{A}$
$C_{in}$	Input capacitance			0.3		pF
$I_{CC}$	Supply current per operator	$T_{amb} = 25\text{ °C}$ $T_{min} < T_{amb} < T_{max}$		8.2	10.5 11.5	mA
CMR	Common mode rejection ratio ( $\delta V_{ic}/\delta V_{io}$ )	$+0.1 < V_{ic} < 3.9\text{ V}$ and $V_{out} = 2.5\text{ V}$ $T_{amb} = 25\text{ °C}$ $T_{min} < T_{amb} < T_{max}$	72 70	97		dB
SVR	Supply voltage rejection ratio ( $\delta V_{CC}/\delta V_{io}$ )	$T_{amb} = 25\text{ °C}$ $T_{min} < T_{amb} < T_{max}$	68 65	75		dB
PSR	Power supply rejection ratio ( $\delta V_{CC}/\delta V_{out}$ )	Positive and negative rail		75		dB
$A_{vd}$	Large signal voltage gain	$R_L = 150\ \Omega$ connected to 1.5 V and $V_{out} = 1\text{ V}$ to 4 V $T_{amb} = 25\text{ °C}$ $T_{min} < T_{amb} < T_{max}$	75 70	84		dB
$I_o$	ISourceI	$V_{id} = +1$ , $V_{out}$ connected to 1.5 V $T_{amb} = 25\text{ °C}$ $T_{min} < T_{amb} < T_{max}$	35 28	55		mA
	Sink	$V_{id} = -1$ , $V_{out}$ connected to 1.5 V $T_{amb} = 25\text{ °C}$ $T_{min} < T_{amb} < T_{max}$	33 28	55		

**Table 3.**  $V_{CC^+} = +5\text{ V}$ ,  $V_{CC^-} = \text{GND}$ ,  $V_{ic} = 2.5\text{ V}$ ,  $T_{amb} = 25\text{ }^\circ\text{C}$   
(unless otherwise specified) (continued)

Symbol	Parameter	Test conditions	Min.	Typ.	Max.	Unit
$V_{oh}$	High level output voltage	$T_{amb} = 25\text{ }^\circ\text{C}$ $R_L = 150\ \Omega$ connected to GND $R_L = 600\ \Omega$ connected to GND $R_L = 2\ \text{k}\Omega$ connected to GND $R_L = 10\ \text{k}\Omega$ connected to GND $R_L = 150\ \Omega$ connected to 2.5 V $R_L = 600\ \Omega$ connected to 2.5 V $R_L = 2\ \text{k}\Omega$ connected to 2.5 V $R_L = 10\ \text{k}\Omega$ connected to 2.5 V $T_{min} < T_{amb} < T_{max}$ $R_L = 150\ \Omega$ connected to GND $R_L = 150\ \Omega$ connected to 2.5 V	4.2 4.60 <sup>(1)</sup> 4.5 4.1 4.4	4.36 4.85 4.90 4.93 4.66 4.90 4.92 4.93		V
$V_{ol}$	Low level output voltage	$T_{amb} = 25\text{ }^\circ\text{C}$ $R_L = 150\ \Omega$ connected to GND $R_L = 600\ \Omega$ connected to GND $R_L = 2\ \text{k}\Omega$ connected to GND $R_L = 10\ \text{k}\Omega$ connected to GND $R_L = 150\ \Omega$ connected to 2.5 V $R_L = 600\ \Omega$ connected to 2.5 V $R_L = 2\ \text{k}\Omega$ connected to 2.5 V $R_L = 10\ \text{k}\Omega$ connected to 2.5 V $T_{min} < T_{amb} < T_{max}$ $R_L = 150\ \Omega$ connected to GND $R_L = 150\ \Omega$ connected to 2.5 V		48 54 55 56 220 105 76 61	150 400 200 450	mV
GBP	Gain bandwidth product	$F = 10\ \text{MHz}$ $A_{VCL} = +11$ $A_{VCL} = -10$		65 55		MHz
Bw	Bandwidth at -3 dB	$A_{VCL} = +1$ $R_L = 150\ \Omega$ connected to 2.5 V		87		MHz
SR	Slew rate	$A_{VCL} = +2$ $R_L = 150\ \Omega // C_L$ to 2.5 V $C_L = 5\ \text{pF}$ $C_L = 30\ \text{pF}$	60	104 105		V/ $\mu\text{s}$
$\phi_m$	Phase margin	$R_L = 150\ \Omega // 30\ \text{pF}$ to 2.5 V		40		$^\circ$ (degree)
$e_n$	Equivalent input noise voltage	$F = 100\ \text{kHz}$		11		nV/ $\sqrt{\text{Hz}}$
THD	Total harmonic distortion	$A_{VCL} = +2$ , $F = 4\ \text{MHz}$ $R_L = 150\ \Omega // 30\ \text{pF}$ to 2.5 V $V_{out} = 1V_{pp}$ $V_{out} = 2V_{pp}$		-61 -54		dB
IM2	Second order intermodulation product	$A_{VCL} = +2$ , $V_{out} = 2V_{pp}$ $R_L = 150\ \Omega$ connected to 2.5 V $F_{in1} = 180\ \text{kHz}$ , $F_{in2} = 280\ \text{kHz}$ spurious measurement at 100 kHz		-76		dBc

**Table 3.**  $V_{CC}^+ = +5\text{ V}$ ,  $V_{CC}^- = \text{GND}$ ,  $V_{ic} = 2.5\text{ V}$ ,  $T_{amb} = 25\text{ }^\circ\text{C}$   
(unless otherwise specified) (continued)

Symbol	Parameter	Test conditions	Min.	Typ.	Max.	Unit
IM3	Third order intermodulation product	$A_{VCL} = +2$ , $V_{out} = 2\text{ V}_{pp}$ $R_L = 150\ \Omega$ to $2.5\text{ V}$ $F_{in1} = 180\text{ kHz}$ , $F_{in2} = 280\text{ kHz}$ spurious measurement at $400\text{ kHz}$		-68		dBc
$\Delta G$	Differential gain	$A_{VCL} = +2$ , $R_L = 150\ \Omega$ to $2.5\text{ V}$ $F = 4.5\text{ MHz}$ , $V_{out} = 2\text{ V}_{pp}$		0.5		%
Df	Differential phase	$A_{VCL} = +2$ , $R_L = 150\ \Omega$ to $2.5\text{ V}$ $F = 4.5\text{ MHz}$ , $V_{out} = 2\text{ V}_{pp}$		0.5		$^\circ$ (degree)
Gf	Gain flatness	$F = \text{DC to } 6\text{ MHz}$ , $A_{VCL} = +2$		0.2		dB
Vo1/Vo2	Channel separation	$F = 1\text{ MHz to } 10\text{ MHz}$		65		dB

1. Tested on the TSH80ILT device only.

**Table 4.**  $V_{CC}^+ = +5\text{ V}$ ,  $V_{CC}^- = -5\text{ V}$ ,  $V_{ic} = \text{GND}$ ,  $T_{amb} = 25\text{ }^\circ\text{C}$   
(unless otherwise specified)

Symbol	Parameter	Test conditions	Min.	Typ.	Max.	Unit
$ V_{io} $	Input offset voltage	$T_{amb} = 25\text{ }^\circ\text{C}$ $T_{min} < T_{amb} < T_{max}$		0.8	10 12	mV
$\Delta V_{io}$	Input offset voltage drift vs. temperature	$T_{min} < T_{amb} < T_{max}$		2		$\mu\text{V}/^\circ\text{C}$
$I_{io}$	Input offset current	$T_{amb} = 25\text{ }^\circ\text{C}$ $T_{min} < T_{amb} < T_{max}$		0.1	3.5 5	$\mu\text{A}$
$I_{ib}$	Input bias current	$T_{amb} = 25\text{ }^\circ\text{C}$ $T_{min} < T_{amb} < T_{max}$		6	15 20	$\mu\text{A}$
$C_{in}$	Input capacitance			0.7		pF
$I_{CC}$	Supply current per operator	$T_{amb} = 25\text{ }^\circ\text{C}$ $T_{min} < T_{amb} < T_{max}$		9.8	12.3 13.4	mA
CMR	Common mode rejection ratio ( $\delta V_{ic}/\delta V_{io}$ )	$-4.9 < V_{ic} < 3.9\text{ V}$ and $V_{out} = \text{GND}$ $T_{amb} = 25\text{ }^\circ\text{C}$ $T_{min} < T_{amb} < T_{max}$	81 72	106		dB
SVR	Supply voltage rejection ratio ( $\delta V_{CC}/\delta V_{io}$ )	$T_{amb} = 25\text{ }^\circ\text{C}$ $T_{min} < T_{amb} < T_{max}$	71 65	77		dB
PSR	Power supply rejection ratio ( $\delta V_{CC}/\delta V_{out}$ )	Positive and negative rail		75		dB
$A_{vd}$	Large signal voltage gain	$R_L = 150\ \Omega$ connected to GND $V_{out} = -4$ to $+4$ $T_{amb} = 25\text{ }^\circ\text{C}$ $T_{min} < T_{amb} < T_{max}$	75 70	86		dB
$I_o$	ISourceI	$V_{id} = +1$ , $V_{out}$ connected to 1.5 V $T_{amb} = 25\text{ }^\circ\text{C}$ $T_{min} < T_{amb} < T_{max}$	35 28	55		mA
	Sink	$V_{id} = -1$ , $V_{out}$ connected to 1.5 V $T_{amb} = 25\text{ }^\circ\text{C}$ $T_{min} < T_{amb} < T_{max}$	30 28	55		
$V_{oh}$	High level output voltage	$T_{amb} = 25\text{ }^\circ\text{C}$ $R_L = 150\ \Omega$ connected to GND $R_L = 600\ \Omega$ connected to GND $R_L = 2\ \text{k}\Omega$ connected to GND $R_L = 10\ \text{k}\Omega$ connected to GND $T_{min} < T_{amb} < T_{max}$ $R_L = 150\ \Omega$ connected to GND	4.2    4.1	4.36 4.85 4.9 4.93		V
$V_{ol}$	Low level output voltage	$T_{amb} = 25\text{ }^\circ\text{C}$ $R_L = 150\ \Omega$ connected to GND $R_L = 600\ \Omega$ connected to GND $R_L = 2\ \text{k}\Omega$ connected to GND $R_L = 10\ \text{k}\Omega$ connected to GND $T_{min} < T_{amb} < T_{max}$ $R_L = 150\ \Omega$ connected to GND		-4.63 -4.86 -4.9 -4.93	-4.4	mV
					-4.3	

**Table 4.**  $V_{CC^+} = +5\text{ V}$ ,  $V_{CC^-} = -5\text{ V}$ ,  $V_{ic} = \text{GND}$ ,  $T_{amb} = 25\text{ }^\circ\text{C}$   
(unless otherwise specified) (continued)

Symbol	Parameter	Test conditions	Min.	Typ.	Max.	Unit
GBP	Gain bandwidth product	$F = 10\text{ MHz}$ $A_{VCL} = +11$ $A_{VCL} = -10$		65 55		MHz
Bw	Bandwidth at -3 dB	$A_{VCL} = +1$ $R_L = 150\ \Omega // 30\text{ pF to GND}$		100		MHz
SR	Slew rate	$A_{VCL} = +2$ $R_L = 150\ \Omega // C_L\text{ to GND}$ $C_L = 5\text{ pF}$ $C_L = 30\text{ pF}$	68	117 118		V/ $\mu\text{s}$
$\phi_m$	Phase margin	$R_L = 150\ \Omega$ connected to GND		40		$^\circ$ (degree)
en	Equivalent input noise voltage	$F = 100\text{ kHz}$		11		nV/ $\sqrt{\text{Hz}}$
THD	Total harmonic distortion	$A_{VCL} = +2$ , $F = 4\text{ MHz}$ $R_L = 150\ \Omega // 30\text{ pF to GND}$ $V_{out} = 1\text{ V}_{pp}$ $V_{out} = 2\text{ V}_{pp}$		-61 -54		dB
IM2	Second order intermodulation product	$A_{VCL} = +2$ , $V_{out} = 2\text{ V}_{pp}$ $R_L = 150\ \Omega$ to GND $F_{in1} = 180\text{ kHz}$ , $F_{in2} = 280\text{ kHz}$ spurious measurement at 100 kHz		-76		dBc
IM3	Third order intermodulation product	$A_{VCL} = +2$ , $V_{out} = 2\text{ V}_{pp}$ $R_L = 150\ \Omega$ to GND $F_{in1} = 180\text{ kHz}$ , $F_{in2} = 280\text{ kHz}$ spurious measurement at 400 kHz		-68		dBc
$\Delta G$	Differential gain	$A_{VCL} = +2$ , $R_L = 150\ \Omega$ to GND $F = 4.5\text{ MHz}$ , $V_{out} = 2\text{ V}_{pp}$		0.5		%
Df	Differential phase	$A_{VCL} = +2$ , $R_L = 150\ \Omega$ to GND $F = 4.5\text{ MHz}$ , $V_{out} = 2\text{ V}_{pp}$		0.5		$^\circ$ (degree)
Gf	Gain flatness	$F = \text{DC to } 6\text{ MHz}$ , $A_{VCL} = +2$		0.2		dB
Vo1/Vo2	Channel separation	$F = 1\text{ MHz to } 10\text{ MHz}$		65		dB

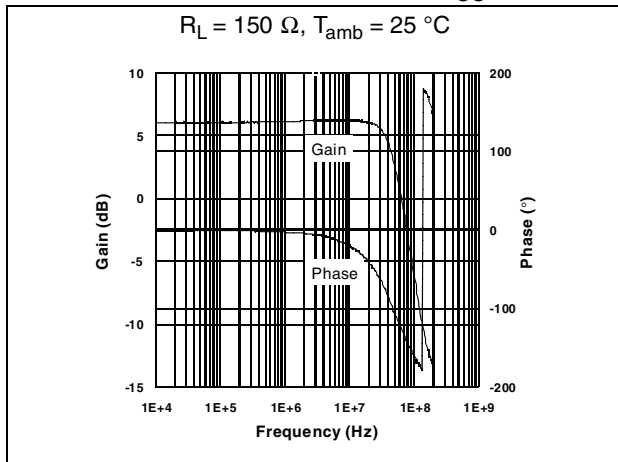
**Table 5. Standby mode -  $V_{CC}^+$ ,  $V_{CC}^-$ ,  $T_{amb} = 25\text{ °C}$  (unless otherwise specified)**

Symbol	Parameter	Test conditions	Min.	Typ.	Max.	Unit
$V_{low}$	Standby low level		$V_{CC}^-$		$(V_{CC}^- + 0.8)$	V
$V_{high}$	Standby high level		$(V_{CC}^- + 2)$		$(V_{CC}^+)$	V
$I_{CC-STBY}$	Current consumption per operator when standby is active	Pin 8 (TSH81) to $V_{CC}^-$		20	55	$\mu\text{A}$
$Z_{out}$	Output impedance ( $R_{out}/C_{out}$ )	$R_{out}$ $C_{out}$		10 17		M $\Omega$ pF
$T_{on}$	Time from standby mode to active mode			2		$\mu\text{s}$
$T_{off}$	Time from active mode to standby mode	Down to $I_{CC-STBY} = 10\text{ }\mu\text{A}$		10		$\mu\text{s}$

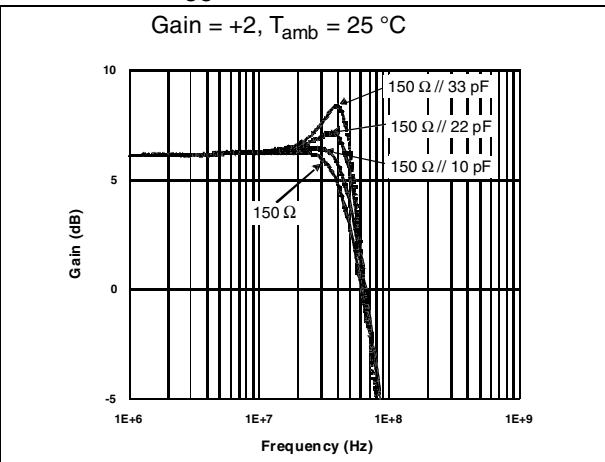
**Table 6. TSH81 standby control pin status**

TSH81 standby control pin 8 ( $\overline{\text{STANDBY}}$ )	Operator status
$V_{low}$	Standby
$V_{high}$	Active

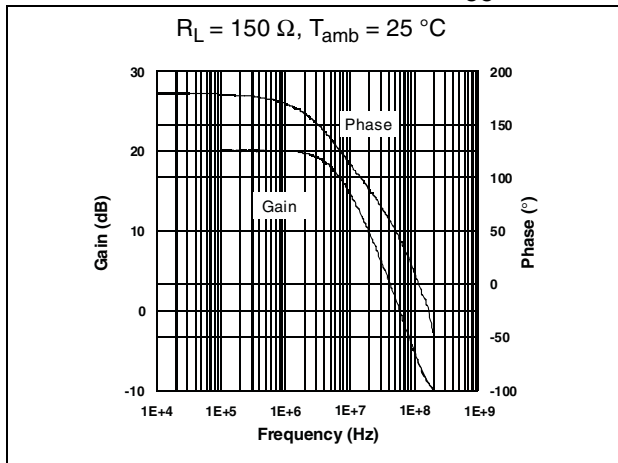
**Figure 1. Closed loop gain and phase vs. frequency (gain = +2,  $V_{CC} = \pm 2.5$  V)**



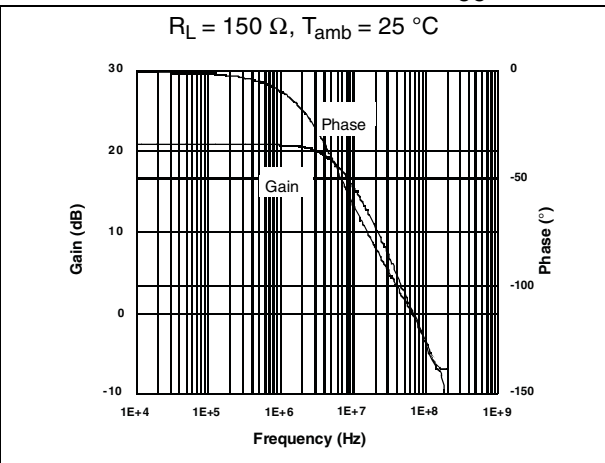
**Figure 2. Overshoot vs. output capacitance ( $V_{CC} = \pm 2.5$  V)**



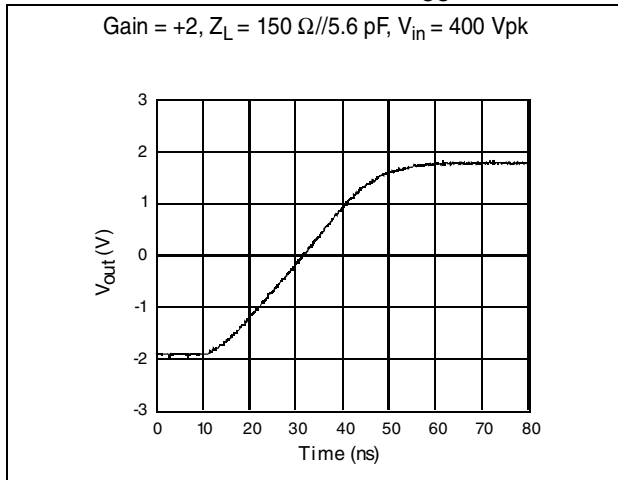
**Figure 3. Closed loop gain and phase vs. frequency (gain = -10,  $V_{CC} = \pm 2.5$  V)**



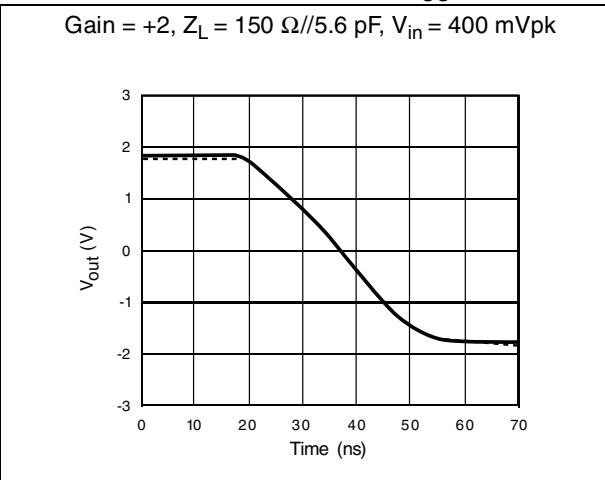
**Figure 4. Closed loop gain and phase vs. frequency (gain = +11,  $V_{CC} = \pm 2.5$  V)**



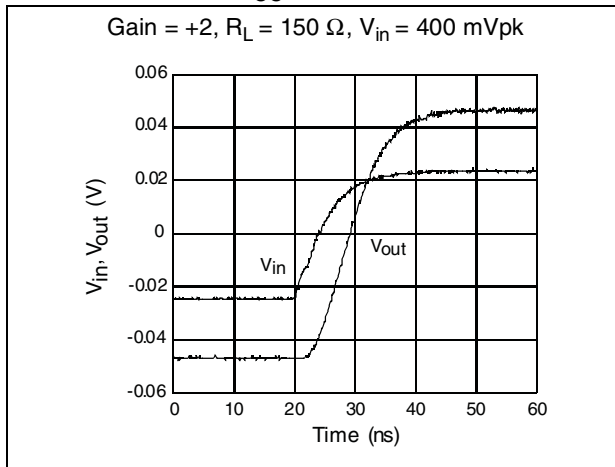
**Figure 5. Large signal measurement – positive slew rate ( $V_{CC} = \pm 2.5$  V)**



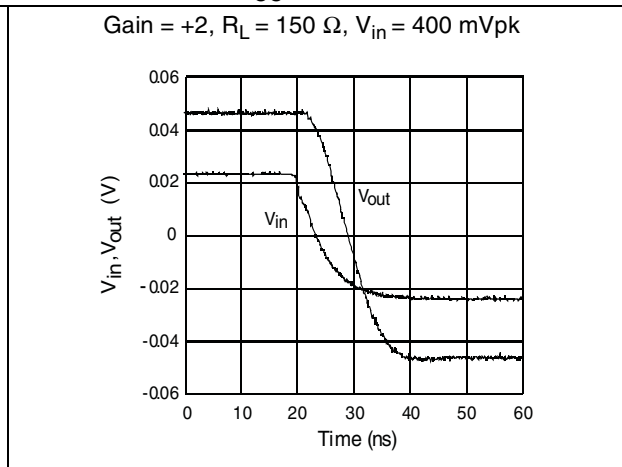
**Figure 6. Large signal measurement – negative slew rate ( $V_{CC} = \pm 2.5$  V)**



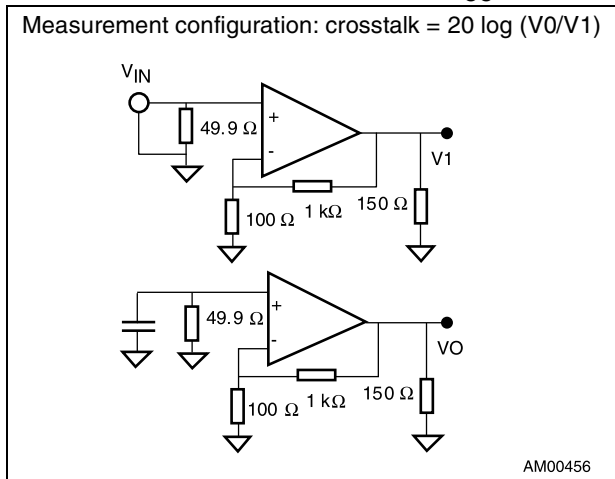
**Figure 7. Small signal measurement – rise time ( $V_{CC} = \pm 2.5\text{ V}$ )**



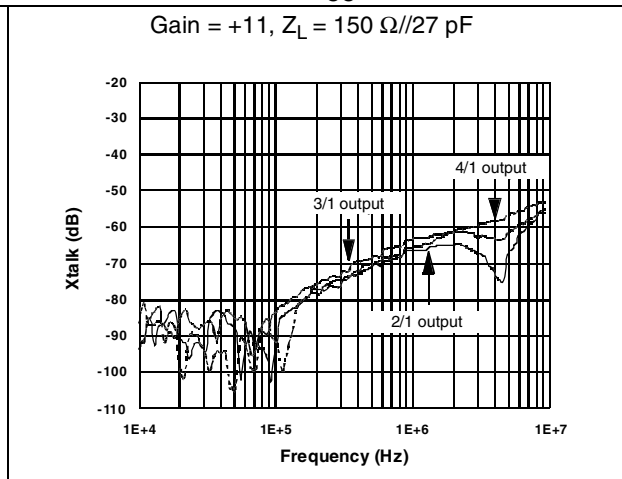
**Figure 8. Small signal measurement – fall time ( $V_{CC} = \pm 2.5\text{ V}$ )**



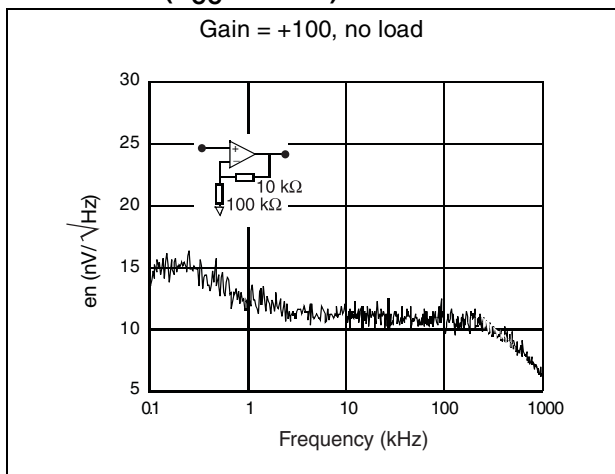
**Figure 9. Channel separation (crosstalk) vs. frequency schematic ( $V_{CC} = \pm 2.5\text{ V}$ )**



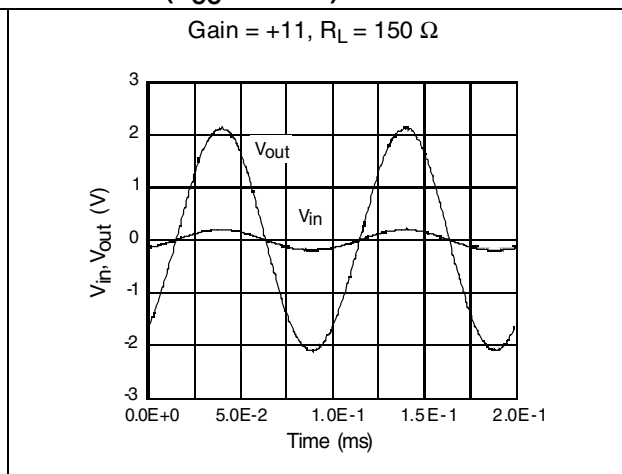
**Figure 10. Channel separation (crosstalk) vs. frequency ( $V_{CC} = \pm 2.5\text{ V}$ )**



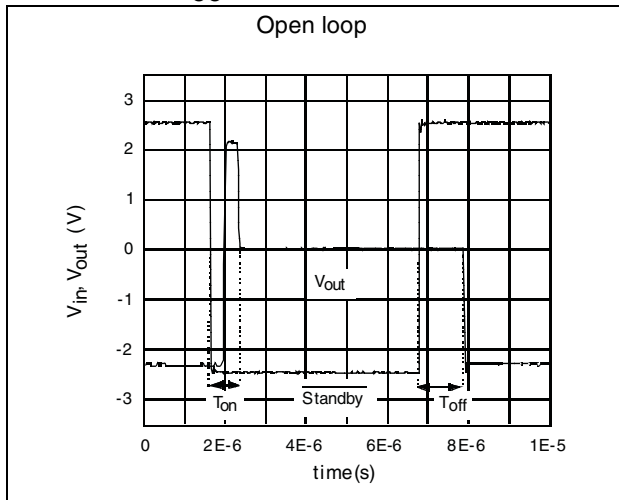
**Figure 11. Equivalent input noise voltage ( $V_{CC} = \pm 2.5\text{ V}$ )**



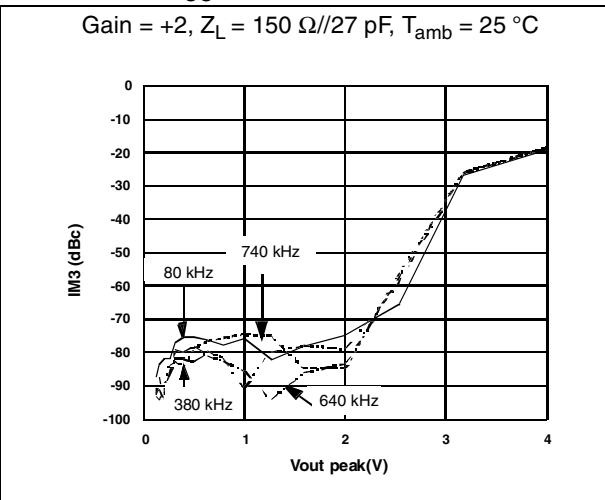
**Figure 12. Maximum output swing ( $V_{CC} = \pm 2.5\text{ V}$ )**



**Figure 13. Standby mode -  $T_{on}$ ,  $T_{off}$**   
( $V_{CC} = \pm 2.5\text{ V}$ )

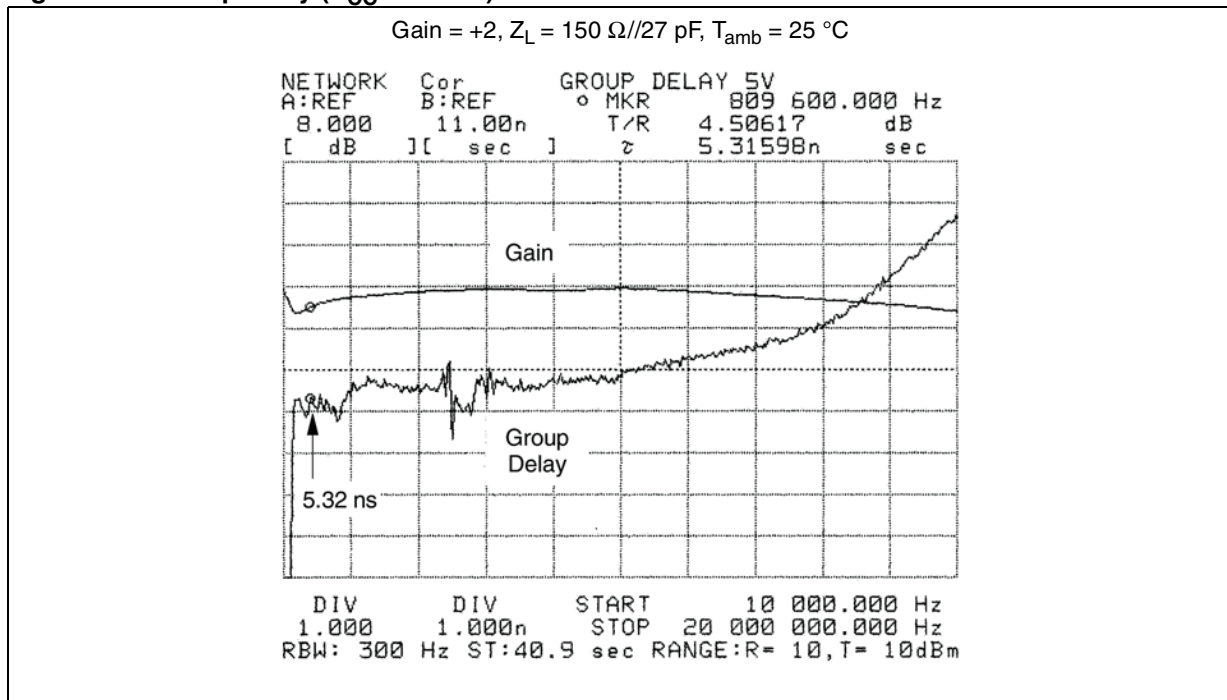


**Figure 14. Third order intermodulation**  
( $V_{CC} = \pm 2.5\text{ V}$ )<sup>(1)</sup>

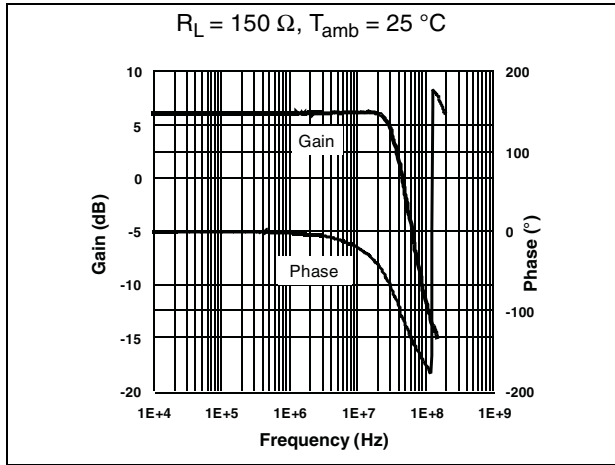


1. The IFR2026 synthesizer generates a two-tone signal ( $F_1 = 180\text{ kHz}$ ,  $F_2 = 280\text{ kHz}$ ), each tone having the same amplitude. The HP3585 spectrum analyzer measures the intermodulation products as a function of the output voltage. The generator and the spectrum analyzer are phase locked for better accuracy.

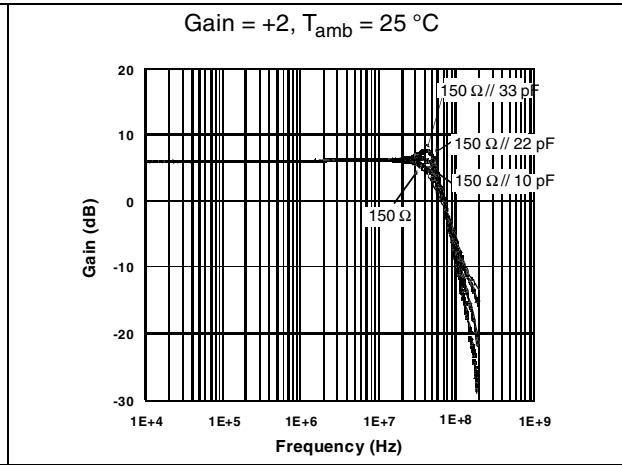
**Figure 15. Group delay ( $V_{CC} = \pm 2.5\text{ V}$ )**



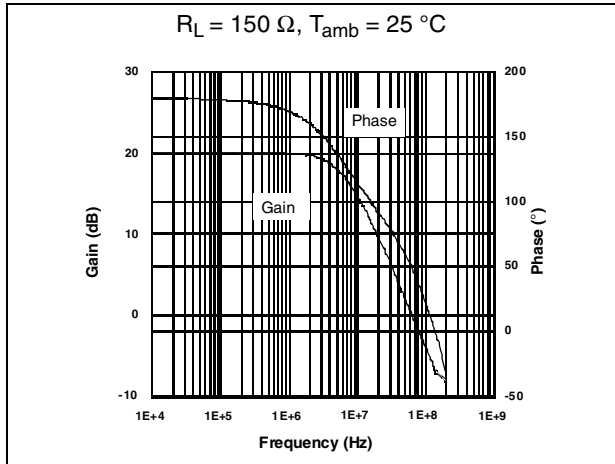
**Figure 16. Closed loop gain and phase vs. frequency (gain = +2,  $V_{CC} = \pm 5$  V)**



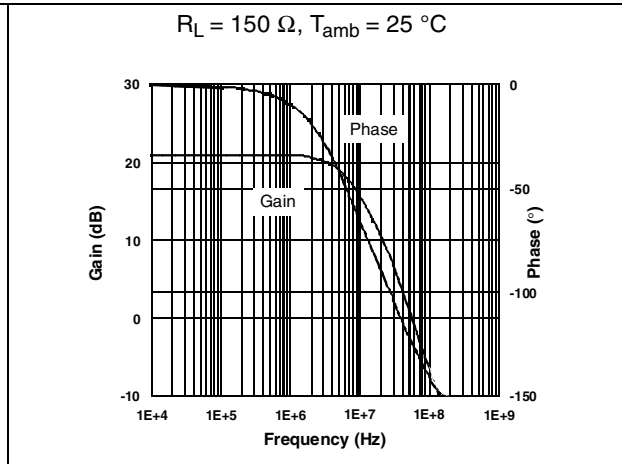
**Figure 17. Overshoot vs. output capacitance ( $V_{CC} = \pm 5$  V)**



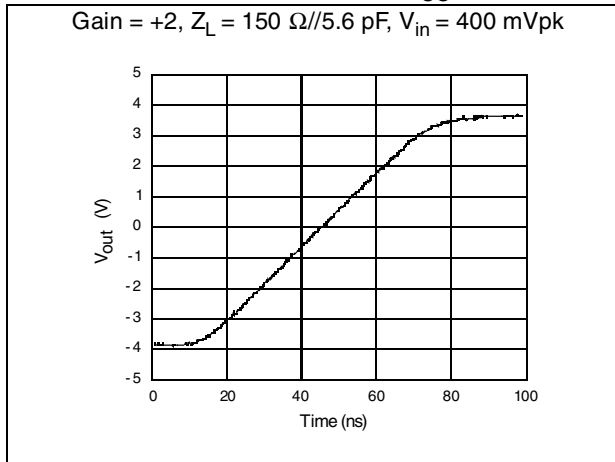
**Figure 18. Closed loop gain and phase vs. frequency (gain = -10,  $V_{CC} = \pm 5$  V)**



**Figure 19. Closed loop gain and phase vs. frequency (gain = +11,  $V_{CC} = \pm 5$  V)**



**Figure 20. Large signal measurement - positive slew rate ( $V_{CC} = \pm 5$  V)**



**Figure 21. Large signal measurement - negative slew rate ( $V_{CC} = \pm 5$  V)**

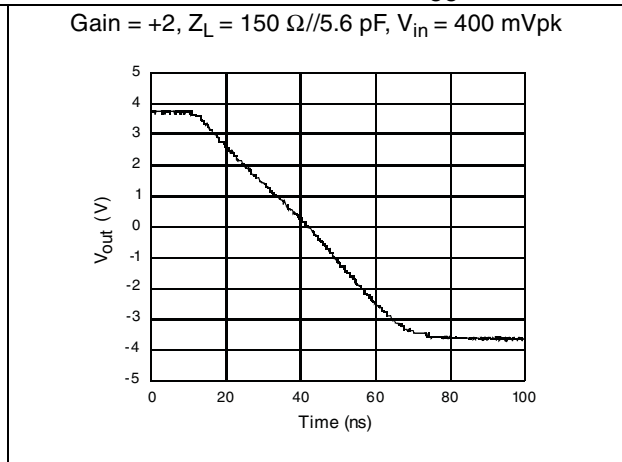


Figure 22. Small signal measurement – rise time ( $V_{CC} = \pm 5\text{ V}$ )

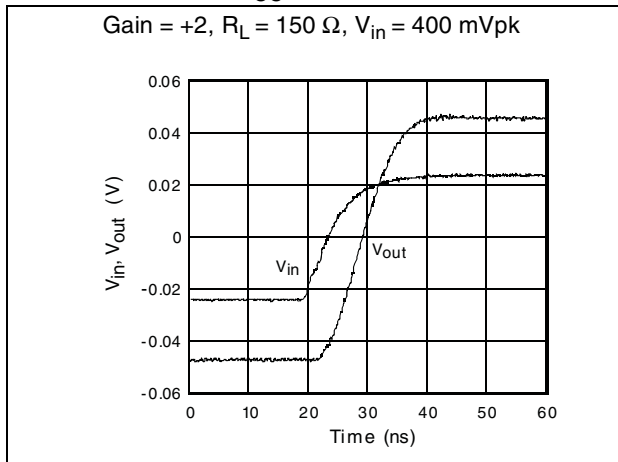


Figure 23. Small signal measurement – fall time ( $V_{CC} = \pm 5\text{ V}$ )

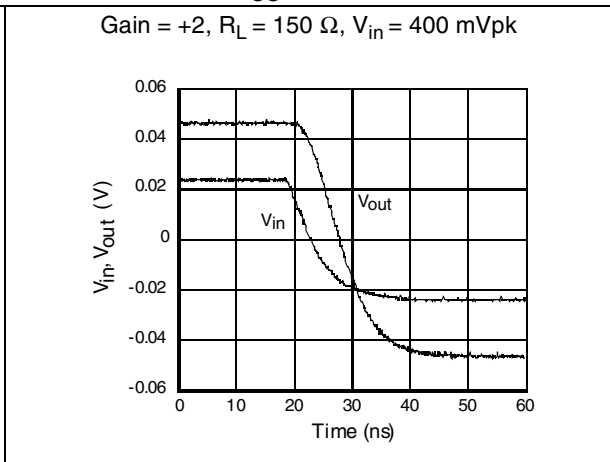


Figure 24. Channel separation (crosstalk) vs. frequency schematic ( $V_{CC} = \pm 5\text{ V}$ )

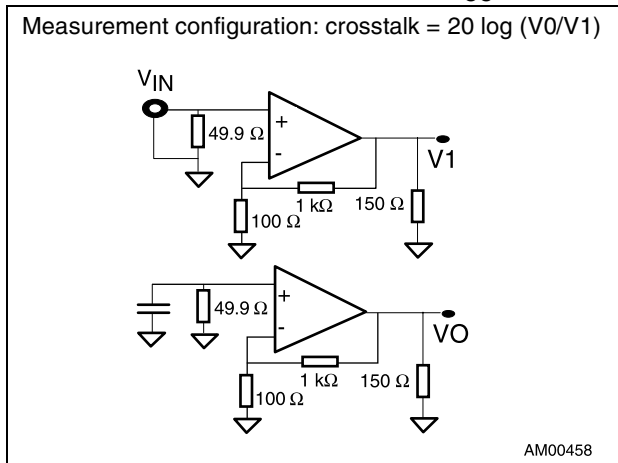


Figure 25. Channel separation (crosstalk) vs. frequency ( $V_{CC} = \pm 5\text{ V}$ )

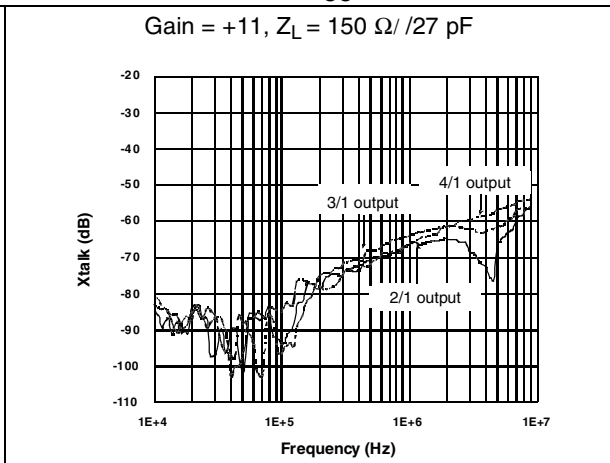


Figure 26. Equivalent input noise voltage ( $V_{CC} = \pm 5\text{ V}$ )

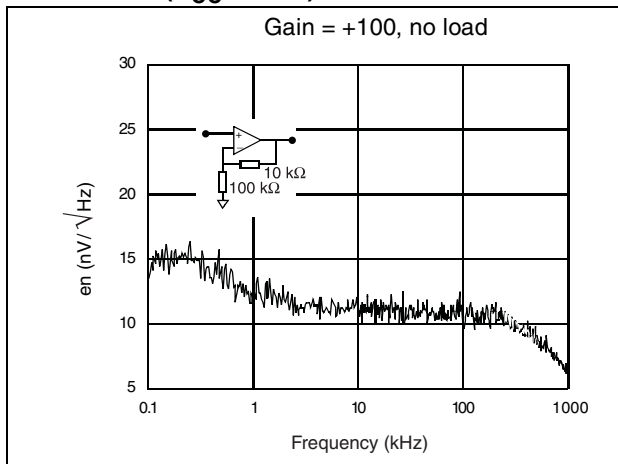
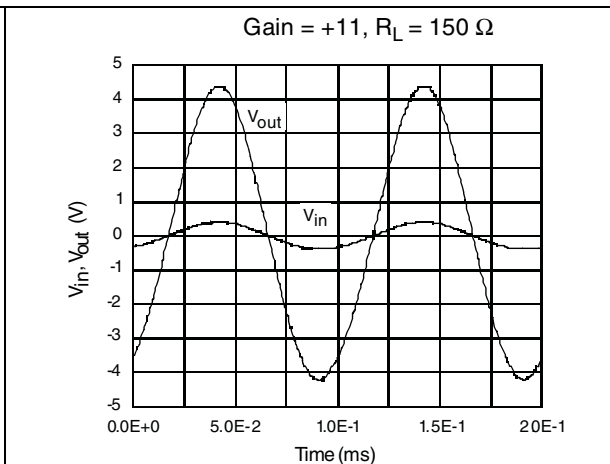
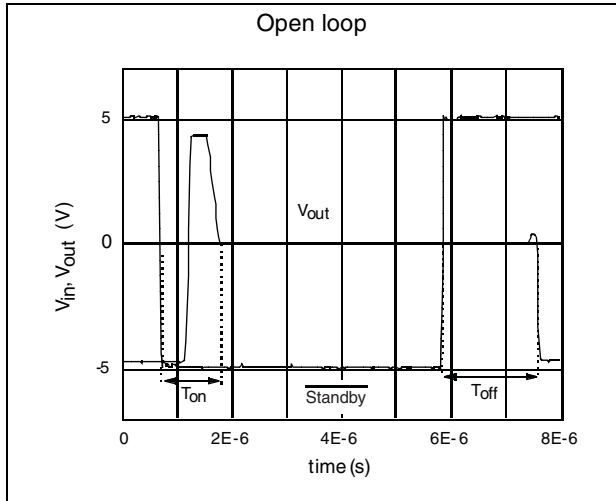


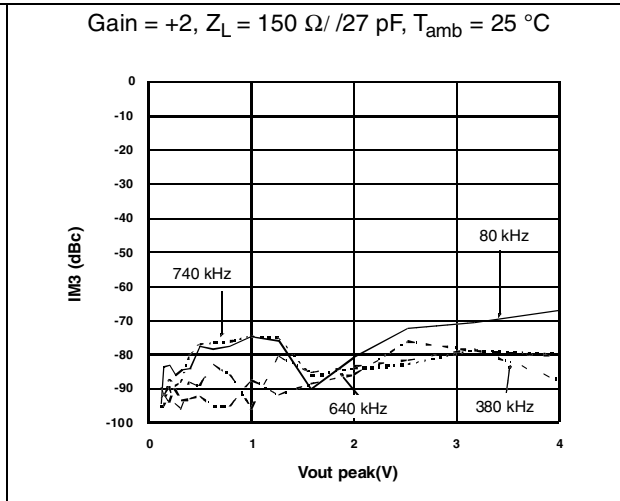
Figure 27. Maximum output swing ( $V_{CC} = \pm 5\text{ V}$ )



**Figure 28. Standby mode -  $T_{on}$ ,  $T_{off}$**   
( $V_{CC} = \pm 5\text{ V}$ )

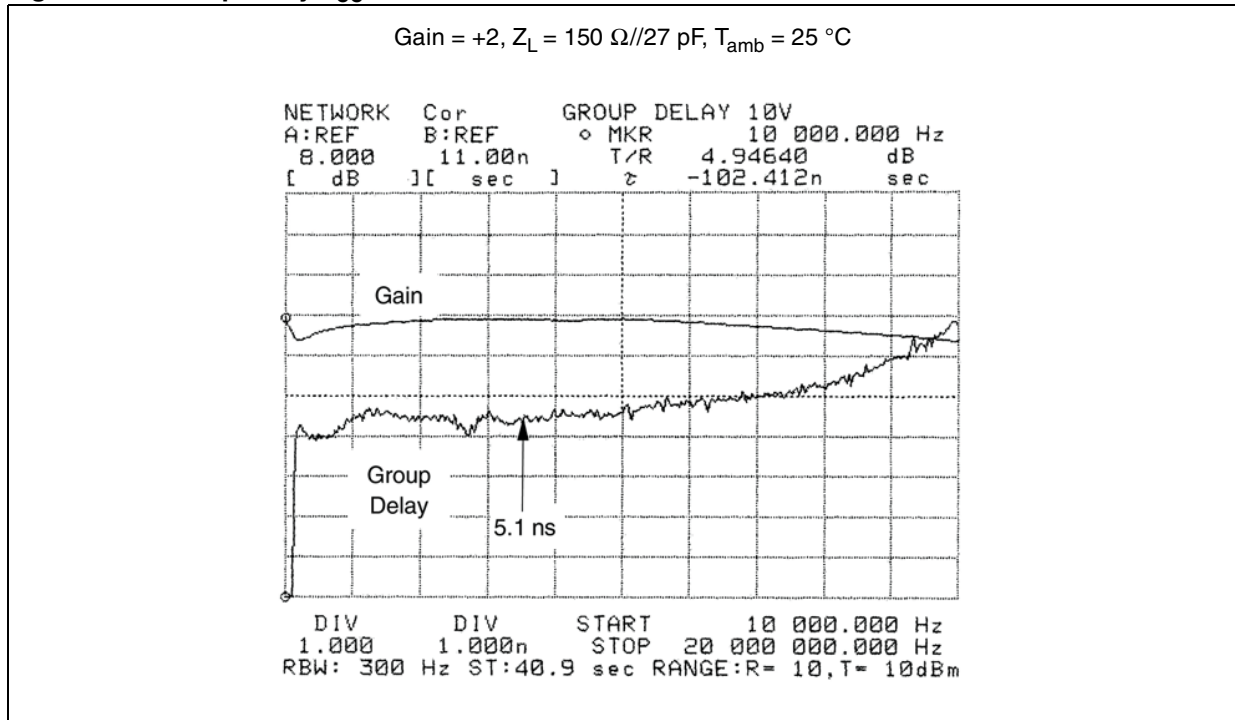


**Figure 29. Third order intermodulation**  
( $V_{CC} = \pm 5\text{ V}$ )<sup>(1)</sup>



1. The IFR2026 synthesizer generates a two-tone signal ( $F_1 = 180\text{ kHz}$ ,  $F_2 = 280\text{ kHz}$ ), each tone having the same amplitude. The HP3585 spectrum analyzer measures the intermodulation products as a function of the output voltage. The generator and the spectrum analyzer are phase locked for better accuracy.

**Figure 30. Group delay  $V_{CC} = \pm 5\text{ V}$**



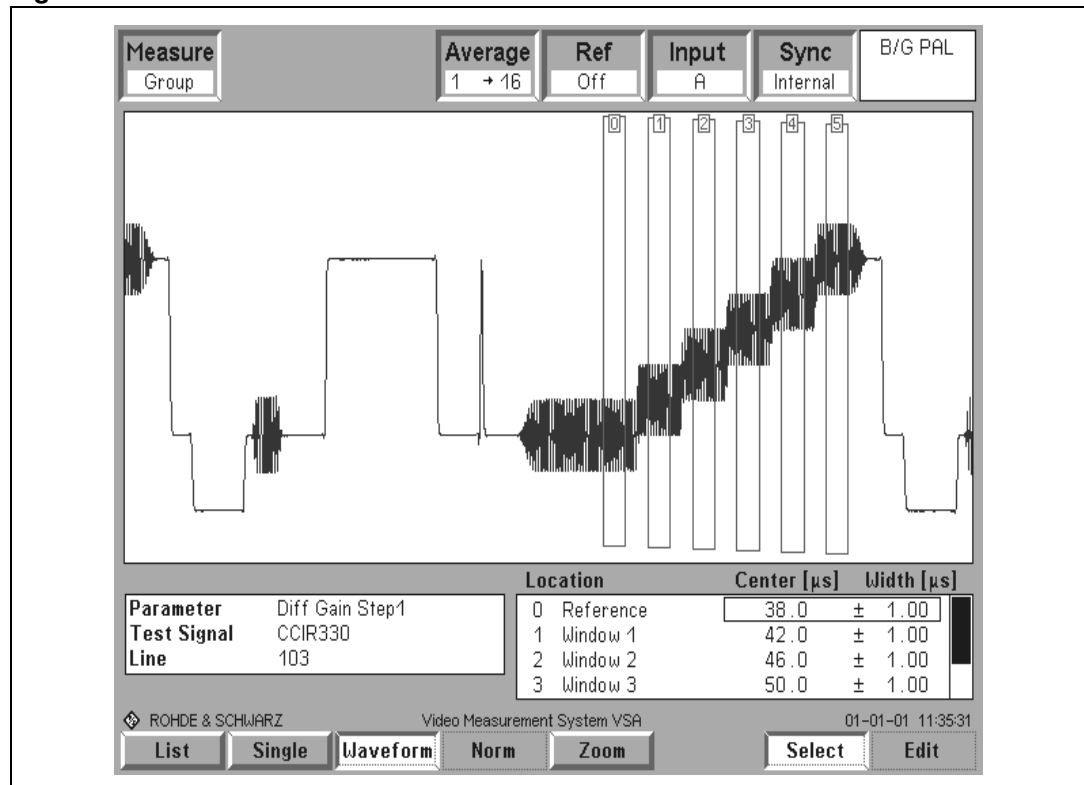
### 3 Test conditions

#### 3.1 Layout precautions

To make the best use of the TSH8x circuits at high frequencies, some precautions have to be taken with regard to the power supplies.

- In high-speed circuit applications, the implementation of a proper ground plane on both sides of the PCB is mandatory to ensure low inductance and low resistance common return.
- Power supply bypass capacitors (4.7  $\mu\text{F}$  and ceramic 100 pF) should be placed as close as possible to the IC pins in order to improve high frequency bypassing and reduce harmonic distortion. The power supply capacitors must be incorporated for both the negative and positive pins.
- All inputs and outputs must be properly terminated with output resistors; thus, the amplifier load is resistive only and the stability of the amplifier will be improved. All leads must be wide and as short as possible especially for op-amp inputs and outputs in order to decrease parasitic capacitance and inductance.
- Time constants result from parasitic capacitance. To reduce time constants in lower-gain applications, use a low feedback resistance (under 1 k $\Omega$ ).
- Choose the smallest possible component sizes (SMD).
- On the output, the load capacitance must be negligible to maintain good stability. You can put a serial resistance as close as possible to the output pin to minimize the effect of the load capacitance.

Figure 31. CCIR330 video line



### 3.2 Video capabilities

To characterize the differential phase and differential gain a CCIR330 video line is used.

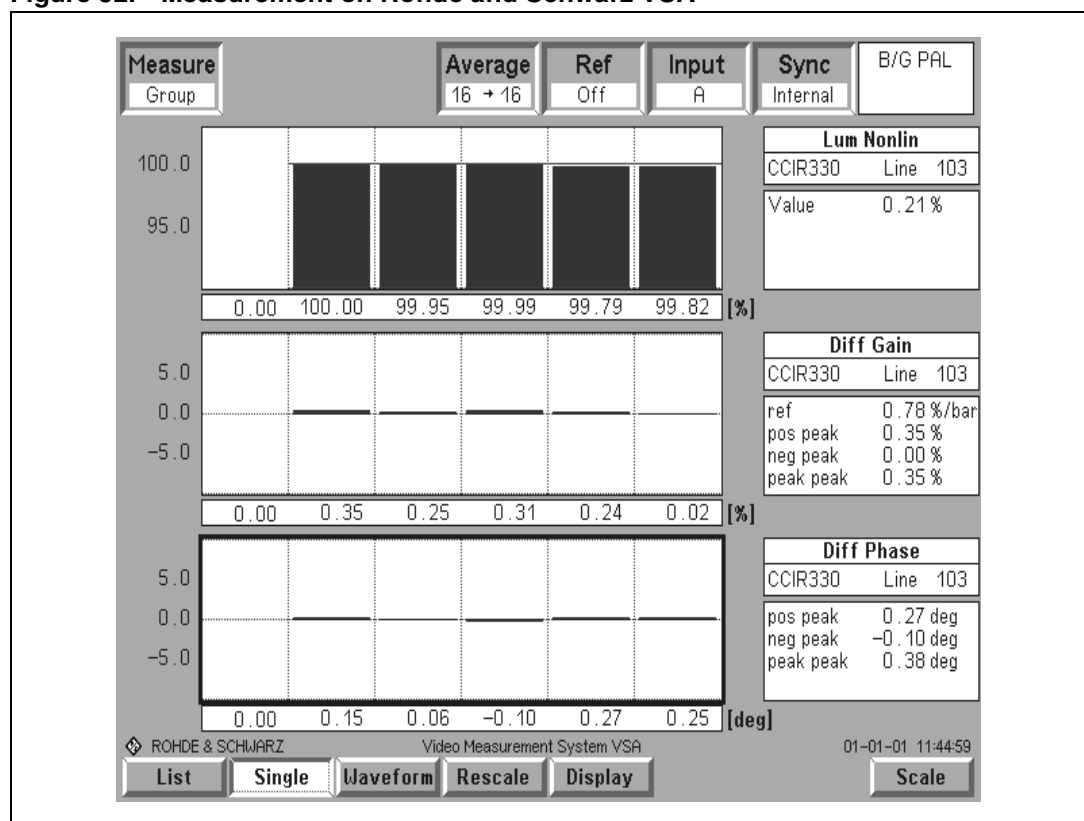
The video line contains five (flat) levels of luminance onto which the chrominance signal is superimposed. The luminance gives various amplitudes which define the saturation of the signal. The chrominance gives various phases which define the color of the signal.

Differential phase (or differential gain) distortion is present if a signal chrominance phase (gain) is affected by the luminance level. The differential phase and gain represent the ability to uniformly process the high frequency information at all luminance levels.

When a differential gain is present, color saturation is not correctly reproduced.

The input generator is the Rohde & Schwarz CCVS. The output measurement is done by the Rohde and Schwarz VSA.

**Figure 32. Measurement on Rohde and Schwarz VSA**



**Table 7. Video results**

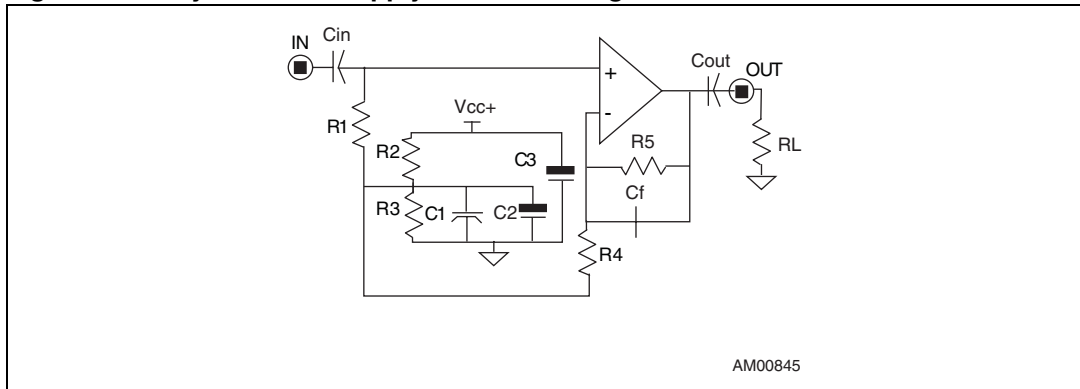
Parameter	Value ( $V_{CC} = \pm 2.5 \text{ V}$ )	Value ( $V_{CC} = \pm 5 \text{ V}$ )	Unit
Lum NL	0.1	0.3	%
Lum NL Step1	100	100	%
Lum NL Step2	100	99.9	%
Lum NL Step3	99.9	99.8	%
Lum NL Step4	99.9	99.9	%
Lum NL Step5	99.9	99.7	%
Diff Gain pos	0	0	%
Diff Gain neg	-0.7	-0.6	%
Diff Gain pp	0.7	0.6	%
Diff Gain Step1	-0.5	-0.3	%
Diff Gain Step2	-0.7	-0.6	%
Diff Gain Step3	-0.3	-0.5	%
Diff Gain Step4	-0.1	-0.3	%
Diff Gain Step5	-0.4	-0.5	%
Diff Phase pos	0	0.1	Degree
Diff Phase neg	-0.2	-0.4	Degree
Diff Phase pp	0.2	0.5	Degree
Diff Phase Step1	-0.2	-0.4	Degree
Diff Phase Step2	-0.1	-0.4	Degree
Diff Phase Step3	-0.1	-0.3	Degree
Diff Phase Step4	0	0.1	Degree
Diff Phase Step5	-0.2	-0.1	Degree

## 4 Precautions on asymmetrical supply operation

The TSH8x device can be used with either a dual or a single supply. If a single supply is used, the inputs are biased to the mid-supply voltage ( $+V_{CC}/2$ ). This bias network must be carefully designed so as to reject any noise present on the supply rail.

As the bias current is  $15 \mu\text{A}$ , you should use a high resistance R1 (approximately  $10 \text{ k}\Omega$ ) to avoid introducing an offset mismatch at the amplifier's inputs.

**Figure 33. Asymmetrical supply schematic diagram**



C1, C2, C3 are bypass capacitors intended to filter perturbations from  $V_{CC}$ . The following capacitor values are appropriate.

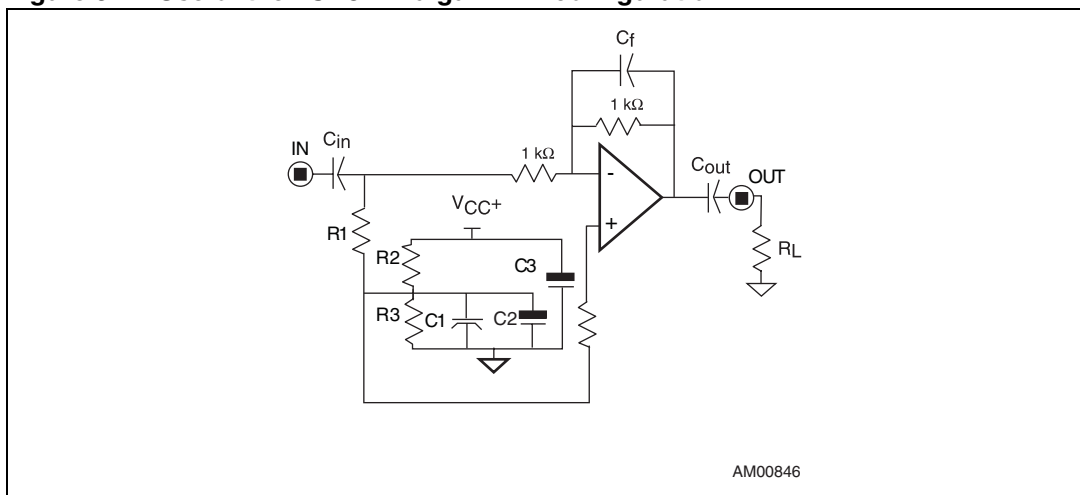
$$C1 = 100 \text{ nF and } C2 = C3 = 100 \mu\text{F}$$

R2 and R3 are such that the current through them must be superior to 100 times the bias current. Therefore, you could use the following resistance values.

$$R2 = R3 = 4.7 \text{ k}\Omega$$

$C_{in}$  and  $C_{out}$  are chosen to filter the DC signal by the low pass filters ( $R1, C_{in}$ ) and ( $R_{out}, C_{out}$ ). With  $R1 = 10 \text{ k}\Omega$ ,  $R_{out} = R_L = 150 \Omega$  and  $C_{in} = 2 \mu\text{F}$ ,  $C_{out} = 220 \mu\text{F}$  the cutoff frequency obtained is lower than  $10 \text{ Hz}$ .

**Figure 34. Use of the TSH8x in a gain = -1 configuration**



## 5 Package information

In order to meet environmental requirements, ST offers these devices in different grades of ECOPACK® packages, depending on their level of environmental compliance. ECOPACK specifications, grade definitions and product status are available at: [www.st.com](http://www.st.com). ECOPACK is an ST trademark.

### 5.1 SOT23-5 package information

Figure 35. SOT23-5 package outline

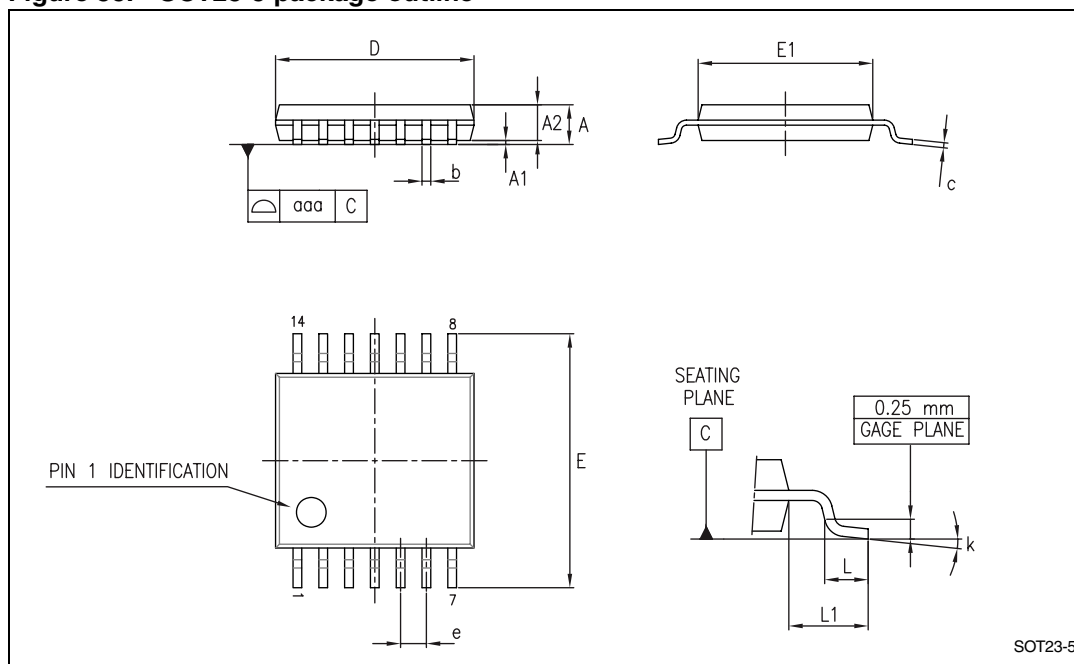


Table 8. SOT23-5 package mechanical data

Symbol	Dimensions					
	Millimeters			Inches		
	Min.	Typ.	Max.	Min.	Typ.	Max.
A	0.90	1.20	1.45	0.035	0.047	0.057
A1			0.15			0.006
A2	0.90	1.05	1.30	0.035	0.041	0.051
B	0.35	0.40	0.50	0.013	0.015	0.019
C	0.09	0.15	0.20	0.003	0.006	0.008
D	2.80	2.90	3.00	0.110	0.114	0.118
D1		1.90			0.075	
e		0.95			0.037	
E	2.60	2.80	3.00	0.102	0.110	0.118
F	1.50	1.60	1.75	0.059	0.063	0.069
L	0.10	0.35	0.60	0.004	0.013	0.023
K	0°		10°			

## 5.2 SO-8 package information

Figure 36. SO-8 package outline

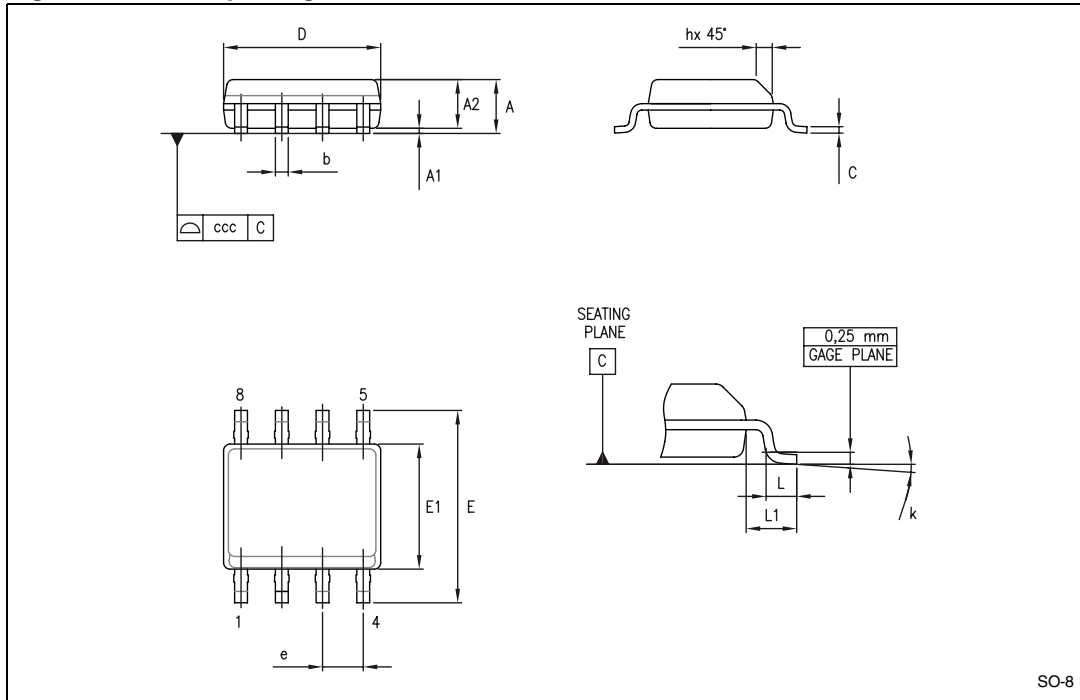


Table 9. SO-8 package mechanical data

Symbol	Dimensions					
	Millimeters			Inches		
	Min.	Typ.	Max.	Min.	Typ.	Max.
A			1.75			0.069
A1	0.10		0.25	0.004		0.010
A2	1.25			0.049		
b	0.28		0.48	0.011		0.019
c	0.17		0.23	0.007		0.010
D	4.80	4.90	5.00	0.189	0.193	0.197
E	5.80	6.00	6.20	0.228	0.236	0.244
E1	3.80	3.90	4.00	0.150	0.154	0.157
e		1.27			0.050	
h	0.25		0.50	0.010		0.020
L	0.40		1.27	0.016		0.050
L1		1.04			0.040	
k	1°		8°	1°		8°
ccc			0.10			0.004

### 5.3 TSSOP8 package information

Figure 37. TSSOP8 package outline

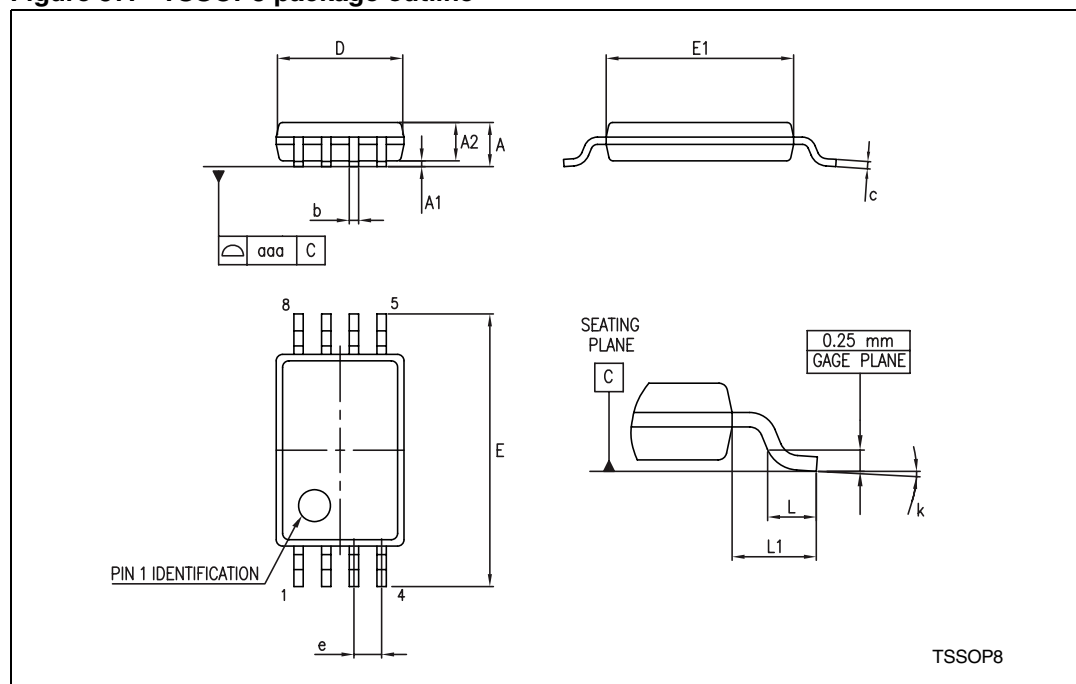


Table 10. TSSOP8 package mechanical data

Symbol	Dimensions					
	Millimeters			Inches		
	Min.	Typ.	Max.	Min.	Typ.	Max.
A			1.20			0.047
A1	0.05		0.15	0.002		0.006
A2	0.80	1.00	1.05	0.031	0.039	0.041
b	0.19		0.30	0.007		0.012
c	0.09		0.20	0.004		0.008
D	2.90	3.00	3.10	0.114	0.118	0.122
E	6.20	6.40	6.60	0.244	0.252	0.260
E1	4.30	4.40	4.50	0.169	0.173	0.177
e		0.65			0.0256	
k	0°		8°	0°		8°
L	0.45	0.60	0.75	0.018	0.024	0.030
L1		1			0.039	
aaa			0.10			0.004

### 5.4 TSSOP14 package information

Figure 38. TSSOP14 package outline

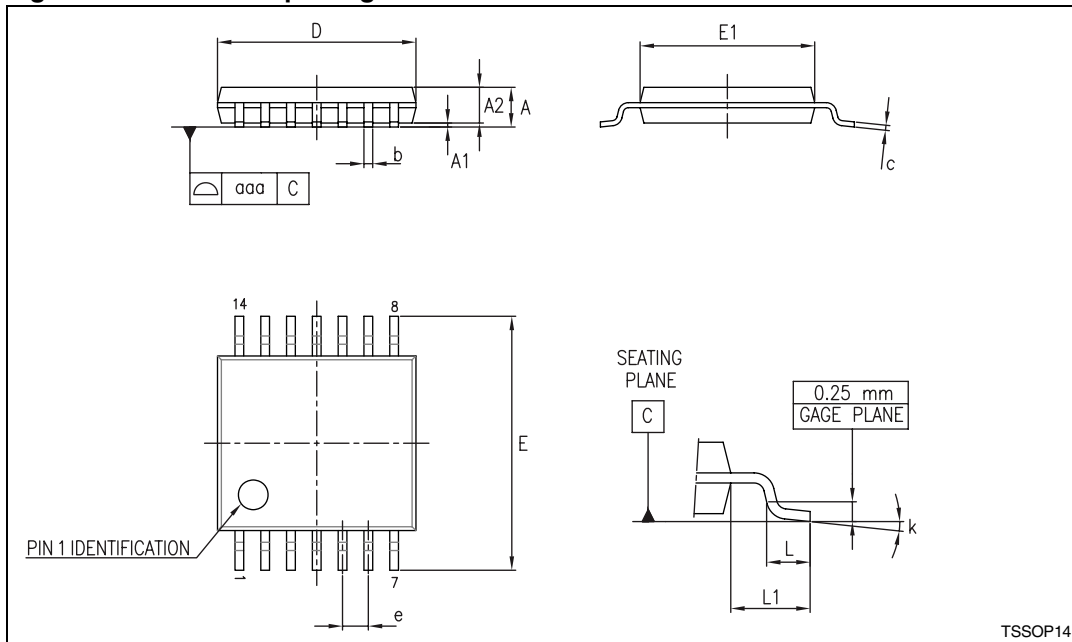


Table 11. TSSOP14 package mechanical data

Symbol	Dimensions					
	Millimeters			Inches		
	Min.	Typ.	Max.	Min.	Typ.	Max.
A			1.20			0.047
A1	0.05		0.15	0.002	0.004	0.006
A2	0.80	1.00	1.05	0.031	0.039	0.041
b	0.19		0.30	0.007		0.012
c	0.09		0.20	0.004		0.0089
D	4.90	5.00	5.10	0.193	0.197	0.201
E	6.20	6.40	6.60	0.244	0.252	0.260
E1	4.30	4.40	4.50	0.169	0.173	0.176
e		0.65			0.0256	
L	0.45	0.60	0.75	0.018	0.024	0.030
L1		1.00			0.039	
k	0°		8°	0°		8°
aaa			0.10			0.004

## 6 Ordering information

Table 12. Order codes

Type	Temperature range	Package	Packaging	Marking	
TSH80ILT	-40 to +85 °C	SOT23-5	Tape and reel	K303	
TSH80IYLT <sup>(1)</sup>		SOT23-5 (Automotive grade level)		K310	
TSH80ID/DT		SO-8	Tube or tape and reel	TSH80I	
TSH80IYD/IYDT <sup>(1)</sup>		SO-8 (Automotive grade level)		SH80IY	
TSH81ID/DT		SO-8		TSH81I	
TSH81IPT			TSSOP8	Tape and reel	SH81I
TSH82ID/DT			SO-8	Tube or tape and reel	TSH82I
TSH82IPT			TSSOP8	Tape and reel	SH82I
TSH84IPT			TSSOP14	Tape and reel	SH84I

1. Qualification and characterization according to AEC Q100 and Q003 or equivalent, advanced screening according to AEC Q001 and Q 002 or equivalent are ongoing.

## 7 Revision history

**Table 13. Document revision history**

Date	Revision	Changes
1-Feb-2003	1	First release.
2-Aug-2005	2	PPAP references inserted in the datasheet, see <a href="#">Table 12: Order codes on page 27</a> .
12-Apr-2007	3	Corrected temperature range for TSH80IYD/IYDT and TSH82IYD/IYDT order codes in <a href="#">Table 12: Order codes on page 27</a> .
24-Oct-2007	4	TSH81IYPT PPAP references inserted in the datasheet, see <a href="#">Table 12: Order codes on page 27</a> .
19-May-2009	5	Added data relating to the quad TSH84 device. Removed TSH81IYPT, TSH81IYD-IYDT, TSH82IYPT and TSH82IYD-IYDT order codes in <a href="#">Table 12: Order codes</a> .
24-Jul-2012	6	Added TSSOP14 package to figure on page 1, updated titles of <a href="#">Figure 1</a> to <a href="#">Figure 30</a> , updated <a href="#">Section 5: Package information</a> , removed TSH80ID-IDT, TSH80IYD, TSH81ID-IDT and TSH82ID order codes from <a href="#">Table 12: Order codes</a> . Modified note 1 below <a href="#">Table 12: Order codes</a> , minor corrections throughout document.

**Please Read Carefully:**

Information in this document is provided solely in connection with ST products. STMicroelectronics NV and its subsidiaries ("ST") reserve the right to make changes, corrections, modifications or improvements, to this document, and the products and services described herein at any time, without notice.

All ST products are sold pursuant to ST's terms and conditions of sale.

Purchasers are solely responsible for the choice, selection and use of the ST products and services described herein, and ST assumes no liability whatsoever relating to the choice, selection or use of the ST products and services described herein.

No license, express or implied, by estoppel or otherwise, to any intellectual property rights is granted under this document. If any part of this document refers to any third party products or services it shall not be deemed a license grant by ST for the use of such third party products or services, or any intellectual property contained therein or considered as a warranty covering the use in any manner whatsoever of such third party products or services or any intellectual property contained therein.

**UNLESS OTHERWISE SET FORTH IN ST'S TERMS AND CONDITIONS OF SALE ST DISCLAIMS ANY EXPRESS OR IMPLIED WARRANTY WITH RESPECT TO THE USE AND/OR SALE OF ST PRODUCTS INCLUDING WITHOUT LIMITATION IMPLIED WARRANTIES OF MERCHANTABILITY, FITNESS FOR A PARTICULAR PURPOSE (AND THEIR EQUIVALENTS UNDER THE LAWS OF ANY JURISDICTION), OR INFRINGEMENT OF ANY PATENT, COPYRIGHT OR OTHER INTELLECTUAL PROPERTY RIGHT.**

**UNLESS EXPRESSLY APPROVED IN WRITING BY TWO AUTHORIZED ST REPRESENTATIVES, ST PRODUCTS ARE NOT RECOMMENDED, AUTHORIZED OR WARRANTED FOR USE IN MILITARY, AIR CRAFT, SPACE, LIFE SAVING, OR LIFE SUSTAINING APPLICATIONS, NOR IN PRODUCTS OR SYSTEMS WHERE FAILURE OR MALFUNCTION MAY RESULT IN PERSONAL INJURY, DEATH, OR SEVERE PROPERTY OR ENVIRONMENTAL DAMAGE. ST PRODUCTS WHICH ARE NOT SPECIFIED AS "AUTOMOTIVE GRADE" MAY ONLY BE USED IN AUTOMOTIVE APPLICATIONS AT USER'S OWN RISK.**

Resale of ST products with provisions different from the statements and/or technical features set forth in this document shall immediately void any warranty granted by ST for the ST product or service described herein and shall not create or extend in any manner whatsoever, any liability of ST.

ST and the ST logo are trademarks or registered trademarks of ST in various countries.

Information in this document supersedes and replaces all information previously supplied.

The ST logo is a registered trademark of STMicroelectronics. All other names are the property of their respective owners.

© 2012 STMicroelectronics - All rights reserved

STMicroelectronics group of companies



Australia - Belgium - Brazil - Canada - China - Czech Republic - Finland - France - Germany - Hong Kong - India - Israel - Italy - Japan - Malaysia - Malta - Morocco - Philippines - Singapore - Spain - Sweden - Switzerland - United Kingdom - United States of America

[www.st.com](http://www.st.com)



## Looking for pricing, stock, or lifecycle information?

Click below to explore more details on WIN SOURCE:

-  [View TSH80IDT on WIN SOURCE](#)
-  [STMicroelectronics Information](#)

## Optimize Your Supply Chain with WIN SOURCE Solutions

-  Global Sourcing Solution
-  Obsolete Management
-  Cost Control Management
-  Shortage Management
-  Alternative Solution
-  Excess Inventory Management