



**THE DATASHEET OF
THS7375IPWR**





4-Channel SDTV Video Amplifier with 6th-Order Filters and 5.6-V/V Gain

 Check for Samples: [THS7375](#)

FEATURES

- Four SDTV Video Amplifiers for CVBS, S-Video, Y'P_BP_R 480i/576i, Y'U'V', G'B'R' (R'G'B'), or SCART
- Integrated Low-Pass Filters:
 - Sixth-Order 9.5-MHz (–3dB) Butterworth
 - –0.1-dB Bandwidth at 6 MHz
 - –1-dB Passband Bandwidth at 8 MHz
 - 54-dB Attenuation at 27 MHz
- Versatile Input Biasing
 - DC-Coupled with 320-mV Output Shift
 - AC-Coupled with Sync-Tip Clamp
 - AC-Coupled with Biasing Allowed
- Built-in 5.6-V/V Gain (14.95 dB)
- +3-V to +5-V Single-Supply Operation
- Rail-to-Rail Output:
 - Output Swings Within 100 mV from the Rails to Allow AC or DC Output Coupling
 - Supports Driving Two Lines per Channel
- Low 9.8-mA at 3.3-V Total Quiescent Current
- Low Differential Gain/Phase of 0.2%/0.35°
- Lead-Free and Green TSSOP-14 Package

APPLICATIONS

- Set Top Box Output Video Buffering
- Portable Media Player Video Buffering
- Security/Surveillance Systems
- DaVinci/OMAP/DMxxx Video Buffering

DESCRIPTION

Fabricated using the revolutionary complementary Silicon-Germanium (SiGe) BiCom3X process, the THS7375 is a low-power, single-supply, 3 V to 5 V four-channel integrated video buffer. It incorporates a sixth-order Butterworth filter (able to be bypassed) that is useful as a digital-to-analog converter (DAC) reconstruction filter or an analog-to-digital converter (ADC) anti-aliasing filter. The 9.5-MHz filter is a perfect choice for SDTV video that includes composite (CVBS), S-video, Y'U'V', G'B'R' (R'G'B'), Y'P_BP_R 480i/576i, and SCART systems.

As part of the THS7375 flexibility, the input can be configured for either ac or dc-coupled inputs. The 320-mV output level shift allows for a full sync dynamic range at the output with 0-V input. The ac-coupled modes include a transparent sync-tip clamp option for CVBS, Y', and G'B'R' signals with sync. AC-coupled biasing for C'/P_B/P_R channels can easily be achieved by adding an external resistor to V_{S+}.

The THS7375 is the perfect choice for all video buffer applications. Its rail-to-rail output stage with 5.6-V/V gain allows for both ac and dc line driving. This architecture makes the THS7375 an ideal choice for DaVinci™ processors. The ability to drive two lines per channel, or 75-Ω loads, allows for maximum flexibility as a video line driver. The 9.8-mA total quiescent current at 3.3 V and 0.1-μA disabled current makes it an excellent choice for USB-powered, portable, or other power-sensitive applications.

The THS7375 is available in a TSSOP-14 package that is lead-free and green (RoHS) compliant.

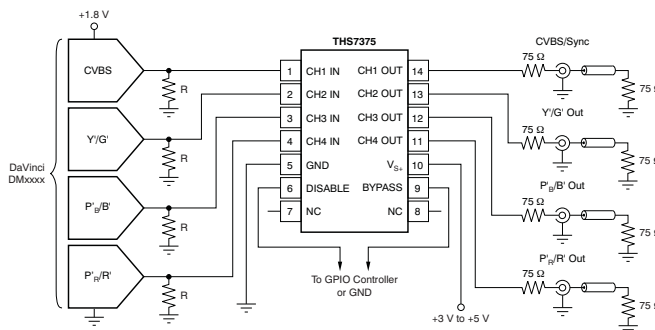

Figure 1. 3.3-V Single-Supply, DC-Input/DC-Output Coupled Video Line Driver



Please be aware that an important notice concerning availability, standard warranty, and use in critical applications of Texas Instruments semiconductor products and disclaimers thereto appears at the end of this data sheet.

DaVinci is a trademark of Texas Instruments Incorporated.
All other trademarks are the property of their respective owners.



This integrated circuit can be damaged by ESD. Texas Instruments recommends that all integrated circuits be handled with appropriate precautions. Failure to observe proper handling and installation procedures can cause damage.

ESD damage can range from subtle performance degradation to complete device failure. Precision integrated circuits may be more susceptible to damage because very small parametric changes could cause the device not to meet its published specifications.

PACKAGE/ORDERING INFORMATION⁽¹⁾

PRODUCT	PACKAGE-LEAD	TRANSPORT MEDIA, QUANTITY	ECO STATUS ⁽²⁾
THS7375IPW	TSSOP-14	Rails, 90	Pb-Free, Green
THS7375IPWR		Tape and Reel, 2000	

- For the most current package and ordering information, see the Package Option Addendum at the end of this document, or visit the device product folder at www.ti.com.
- These packages conform to Lead (Pb)-free and green manufacturing specifications. Additional details including specific material content can be accessed at www.ti.com/leadfree.
GREEN: TI defines Green to mean Lead (Pb)-Free and in addition, uses less package materials that do not contain halogens, including bromine (Br), or antimony (Sb) above 0.1% of total product weight. N/A: Not yet available Lead (Pb)-Free; for estimated conversion dates, go to www.ti.com/leadfree. Pb-FREE: TI defines Lead (Pb)-Free to mean RoHS compatible, including a lead concentration that does not exceed 0.1% of total product weight, and, if designed to be soldered, suitable for use in specified lead-free soldering processes.

ABSOLUTE MAXIMUM RATINGS⁽¹⁾

Over operating free-air temperature range unless otherwise noted.

		THS7375	UNIT
Supply voltage, V_{S+} to GND		5.5	V
Input voltage, V_I		-0.4 to V_{S+}	V
Output current, I_O		±90	mA
Continuous power dissipation		See Dissipation Ratings Table	
Maximum junction temperature, any condition ⁽²⁾ T_J		+150	°C
Maximum junction temperature, continuous operation, long-term reliability ⁽³⁾ , T_J		+125	°C
Storage temperature range, T_{STG}		-65 to +150	°C
Lead temperature 1,6 mm (1/16 inch) from case for 10 seconds		+300	°C
ESD ratings	Human body model (HBM)	2000	V
	Charged device model (CDM)	1000	V
	Machine model	200	V

- Stresses above these ratings may cause permanent damage. Exposure to absolute maximum conditions for extended periods may degrade device reliability. These are stress ratings only, and functional operation of the device at these or any other conditions beyond those specified is not implied.
- The absolute maximum junction temperature under any condition is limited by the constraints of the silicon process.
- The absolute maximum junction temperature for continuous operation is limited by the package constraints. Operation above this temperature may result in reduced reliability and/or lifetime of the device.

DISSIPATION RATINGS

PACKAGE	θ_{JC} (°C/W)	θ_{JA} (°C/W)	AT $T_A \leq +25^\circ\text{C}$ POWER RATING ⁽¹⁾	AT $T_A = +85^\circ\text{C}$ POWER RATING ⁽¹⁾
TSSOP-14 (PW)	35	115 ⁽²⁾	870 mW	348 mW

- Power rating is determined with a junction temperature of +125°C. This is the point where performance starts to degrade and long-term reliability starts to be reduced. Thermal management of the final PCB should strive to keep the junction temperature at or below +125°C for best performance and reliability.
- These data were taken with the JEDEC High-K test printed circuit board (PCB). For the JEDEC low-K test PCB, the θ_{JA} is +185°C.

RECOMMENDED OPERATING CONDITIONS

	MIN	NOM	MAX	UNIT
Supply voltage, V_{S+}	3		5	V
Ambient temperature, T_A	-40		+85	°C

ELECTRICAL CHARACTERISTICS: $V_{S+} = +3.3\text{ V}$
 $R_L = 150\ \Omega$ to GND, dc-coupled input and output, Filter Mode, unless otherwise noted.

PARAMETER	TEST CONDITIONS	THS7375						
		TYP	OVER TEMPERATURE				MIN/ TYP/ MAX	UNITS
		+25°C	+25°C	0°C to +70°C	–40°C to +85°C			
AC PERFORMANCE								
Small-signal bandwidth (–3 dB)	$V_O = 0.2\ V_{PP}^{(1)}$	9.5	7.6/11.4	7.4/11.6	7.3/11.7	Min/ Max	MHz	
Large-signal bandwidth (–3 dB)	$V_O = 2\ V_{PP}^{(1)}$	9.5	7.6/11.4	7.4/11.6	7.3/11.7	Min/ Max	MHz	
–1 dB passband bandwidth		8				Typ	MHz	
Bypass mode bandwidth (–3 dB)	$V_O = 0.2\ V_{PP}$	70				Typ	MHz	
Slew rate	Bypass mode	150				Typ	V/ μ s	
Attenuation with respect to 500 kHz	$f = 6.75\ \text{MHz}^{(2)}$	0.3	–0.9/1.1	–1/1.4	–1.1/1.6	Min/ Max	dB	
	$f = 27\ \text{MHz}^{(2)}$	54	42	40	39	Min	dB	
Group delay	$f = 100\ \text{kHz}$	75				Typ	ns	
Group delay variation with respect to 100 kHz	$f = 5.1\ \text{MHz}$	10				Typ	ns	
Channel-to-channel delay		0.3				Typ	ns	
Differential gain	NTSC/PAL	0.2/0.3				TYP	%	
Differential phase	NTSC/PAL	0.35/0.5				Typ	°	
Total harmonic distortion	$f = 1\ \text{MHz}, V_O = 2\ V_{PP}$	–65				Typ	dB	
Signal-to-noise ratio	100 kHz to 6 MHz: non-weighted / unified weighting	61 / 70				Typ	dB	
Channel-to-channel crosstalk	$f = 1\ \text{MHz}$, worst case	–55				Typ	dB	
AC gain—all channels		14.95	14.7/15.3	14.6/15.4	14.6/15.4	Min/ Max	dB	
Output impedance	$f = 5\ \text{MHz}$, Filter Mode	1.4				Typ	Ω	
DC PERFORMANCE								
Biased output voltage	$V_{IN} = 0\ \text{V}$	320	170/430	160/440	150/450	Min/ Max	mV	
Input voltage range	DC input, limited by output	–0.1/0.52				Typ	V	
Sync tip clamp charge current	$V_{IN} = -0.1\ \text{V}$	200	140	130	120	Min	μ A	
Input resistance		800				Typ	k Ω	
Input capacitance		2				Typ	pF	
OUTPUT CHARACTERISTICS								
High output voltage swing	$R_L = 150\ \Omega$ to +1.65 V	3.15				Typ	V	
	$R_L = 150\ \Omega$ to GND	3.1	2.85	2.75	2.75	Min	V	
	$R_L = 75\ \Omega$ to +1.65 V	3.1				Typ	V	
	$R_L = 75\ \Omega$ to GND	3				Typ	V	
Low output voltage swing	$R_L = 150\ \Omega$ to +1.65 V ($V_{IN} = -0.2\ \text{V}$)	0.05				Typ	V	
	$R_L = 150\ \Omega$ to GND ($V_{IN} = -0.2\ \text{V}$)	0.02	0.12	0.16	0.17	Max	V	
	$R_L = 75\ \Omega$ to +1.65 V ($V_{IN} = -0.2\ \text{V}$)	0.1				Typ	V	
	$R_L = 75\ \Omega$ to GND ($V_{IN} = -0.2\ \text{V}$)	0.05				Typ	V	
Output current (sourcing)	$R_L = 10\ \Omega$ to +1.65 V	80				Typ	mA	
Output current (sinking)	$R_L = 10\ \Omega$ to +1.65 V	70				Typ	mA	

(1) The min/max values listed for this specification are ensured by design and characterization only.

(2) 3.3-V supply filter specifications are ensured by 100% testing at 5-V supply along with design and characterization only.

ELECTRICAL CHARACTERISTICS: $V_{S+} = +3.3\text{ V}$ (continued)

$R_L = 150\ \Omega$ to GND, dc-coupled input and output, Filter Mode, unless otherwise noted.

PARAMETER	TEST CONDITIONS	THS7375						UNITS
		TYP	OVER TEMPERATURE				MIN/ TYP/ MAX	
		+25°C	+25°C	0°C to +70°C	–40°C to +85°C			
POWER SUPPLY								
Maximum operating voltage	V_{S+} to GND	3.3	5.5	5.5	5.5	Max	V	
Minimum operating voltage	V_{S+} to GND ⁽³⁾	3.3	2.85	2.85	2.85	Min	V	
Maximum quiescent current	$V_{IN} = 0\text{ V}; V_{S+} = 3.3\text{ V}$	9.8	12	13	14	Max	mA	
Minimum quiescent current	$V_{IN} = 0\text{ V}; V_{S+} = 3.3\text{ V}$	9.8	8	7	6.5	Min	mA	
Power-supply rejection (+PSRR)		53				Typ	dB	
LOGIC CHARACTERISTICS⁽⁴⁾								
V_{IH}	Disabled or bypass engaged	1.8	2	2	2	Min	V	
V_{IL}	Enabled or bypass disengaged	0.7	0.65	0.6	0.6	Max	V	
I_{IH}		0.2				Typ	μA	
I_{IL}		0.2				Typ	μA	
Disable time		100				Typ	ns	
Enable time		100				Typ	ns	
Bypass/filter switch time		5				Typ	ns	
Disabled quiescent current	Disable pin = 2 V	0.1	10	10	10	Max	μA	
Disabled output impedance	Disable pin = 2 V	20 3				Typ	k Ω pF	

(3) The min/max values listed for this specification are ensured by design and characterization only.

(4) The logic input pins should not be left floating. They must be connected to logic low (or GND) or logic high (or V_{S+}).

ELECTRICAL CHARACTERISTICS: $V_{S+} = +5\text{ V}$
 $R_L = 150\ \Omega$ to GND, dc-coupled input and output, Filter Mode, unless otherwise noted.

PARAMETER	TEST CONDITIONS	THS7375						
		TYP	OVER TEMPERATURE				MIN/ TYP/ MAX	UNITS
		+25°C	+25°C	0°C to +70°C	–40°C to +85°C			
AC PERFORMANCE								
Small-signal bandwidth (–3 dB)	$V_O = 0.2\ V_{PP}^{(1)}$	9.5	7.6/11.4	7.4/11.6	7.3/11.7	Min/ Max	MHz	
Large-signal bandwidth (–3 dB)	$V_O = 2\ V_{PP}^{(1)}$	9.5	7.6/11.4	7.4/11.6	7.3/11.7	Min/ Max	MHz	
–1 dB passband bandwidth		8				Typ	MHz	
Bypass mode bandwidth (–3 dB)	$V_O = 0.2\ V_{PP}$	70				Typ	MHz	
Slew rate	Bypass mode	150				Typ	V/ μ s	
Attenuation with respect to 500 kHz	$f = 6.75\ \text{MHz}$	0.3	–0.9/1.1	–1/1.4	–1.1/1.6	Min/ Max	dB	
	$f = 27\ \text{MHz}$	54	42	40	39	Min	dB	
Group delay	$f = 100\ \text{kHz}$	75				Typ	ns	
Group delay variation with respect to 100 kHz	$f = 5.1\ \text{MHz}$	10				Typ	ns	
Channel-to-channel delay		0.3				Typ	ns	
Differential gain	NTSC/PAL	0.2/0.3				Typ	%	
Differential phase	NTSC/PAL	0.35/0.5				Typ	°	
Total harmonic distortion	$f = 1\ \text{MHz}, V_O = 2\ V_{PP}$	–70				Typ	dB	
Signal-to-noise ratio	100 kHz to 6 MHz: non-weighted / unified weighting	61/70				Typ	dB	
Channel-to-channel crosstalk	$f = 1\ \text{MHz}$, worst case	–55				Typ	dB	
AC gain—all channels		14.95	14.7/15.3	14.6/15.4	14.6/15.4	Min/ Max	dB	
Output impedance	$f = 5\ \text{MHz}$; filter mode	1.4				Typ	Ω	
DC PERFORMANCE								
Biased output voltage/level shift	$V_{IN} = 0\ \text{V}$	320	170/430	160/440	150/450	Min/ Max	mV	
Input voltage range	Limited by output	–0.1/0.8				Typ	V	
Sync tip clamp charge current	$V_{IN} = -0.1\ \text{V}$	200	140	130	120	Min	μ A	
Input resistance		800				Typ	k Ω	
Input capacitance		2				Typ	pF	
OUTPUT CHARACTERISTICS								
High output voltage swing	$R_L = 150\ \Omega$ to +2.5V	4.85				Typ	V	
	$R_L = 150\ \Omega$ to GND	4.75	4.4	4.3	4.3	Min	V	
	$R_L = 75\ \Omega$ to +2.5V	4.7				Typ	V	
	$R_L = 75\ \Omega$ to GND	4.5				Typ	V	
Low output voltage swing	$R_L = 150\ \Omega$ to +2.5V ($V_{IN} = -0.2\ \text{V}$)	0.05				Typ	V	
	$R_L = 150\ \Omega$ to GND ($V_{IN} = -0.2\ \text{V}$)	0.02	0.12	0.16	0.17	Max	V	
	$R_L = 75\ \Omega$ to +2.5V ($V_{IN} = -0.2\ \text{V}$)	0.1				Typ	V	
	$R_L = 75\ \Omega$ to GND ($V_{IN} = -0.2\ \text{V}$)	0.05				Typ	V	
Output current (sourcing)	$R_L = 10\ \Omega$ to +2.5 V	90				Typ	mA	
Output current (sinking)	$R_L = 10\ \Omega$ to +2.5 V	85				Typ	mA	

(1) The min/max values listed for this specification are ensured by design and characterization only.

ELECTRICAL CHARACTERISTICS: $V_{S+} = +5\text{ V}$ (continued)

$R_L = 150\ \Omega$ to GND, dc-coupled input and output, Filter Mode, unless otherwise noted.

PARAMETER	TEST CONDITIONS	THS7375						UNITS
		TYP	OVER TEMPERATURE				MIN/ TYP/ MAX	
		+25°C	+25°C	0°C to +70°C	–40°C to +85°C			
POWER SUPPLY								
Maximum operating voltage	V_{S+} to GND	5	5.5	5.5	5.5	Max	V	
Minimum operating voltage	V_{S+} to GND ⁽²⁾	5	2.85	2.85	2.85	Min	V	
Maximum quiescent current	$V_{IN} = 0\text{ V}$, $V_{S+} = 5\text{ V}$	10.3	12.5	13.5	14.5	Max	mA	
Minimum quiescent current	$V_{IN} = 0\text{ V}$, $V_{S+} = 5\text{ V}$	10.3	8	7.5	7	Min	mA	
Power-supply rejection (+PSRR)		53				Typ	dB	
DISABLE CHARACTERISTICS⁽³⁾								
V_{IH}	Disabled/bypass engaged ⁽⁴⁾	2.1	2.2	2.2	2.2	Min	V	
V_{IL}	Enabled/bypass disengaged	0.8	0.8	0.8	0.8	Max	V	
I_{IH}		0.2				Typ	μA	
I_{IL}		0.2				Typ	μA	
Disable time		80				Typ	ns	
Enable time		80				Typ	ns	
Bypass/filter switch time		5				Typ	ns	
Disabled quiescent current	Disable pin = 3 V	1	10	10	10	Max	μA	
Disabled output impedance	Disable pin = 3 V	20 3				Typ	k Ω pF	

(2) The min/max values listed for this specification are ensured by design and characterization only.

(3) The logic input pins should not be left floating. They must be connected to logic low (or GND) or logic high (or V_{S+}).

(4) Defined as applied logic voltage to achieve total quiescent current of less than 100 μA .

PIN CONFIGURATION

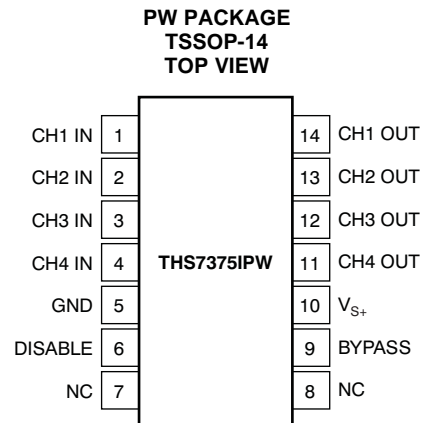
Table 1. TERMINAL FUNCTIONS

TERMINAL		I/O	DESCRIPTION
NAME	NO.		
CH1 IN	1	I	Video input; channel 1
CH2 IN	2	I	Video input; channel 2
CH3 IN	3	I	Video input; channel 3
CH4 IN	4	I	Video input; channel 4
GND	5	I	Ground pin for all internal circuitry
DISABLE	6	I	Disable pin. Logic high disables the part; logic low enables the part. This pin must not be left floating. It must be connected to a defined logic state (or GND or V_{S+})
NC	7, 8	—	No internal connection
BYPASS	9	I	Internal filter bypass. Logic high bypasses the internal low-pass filter; logic low uses the internal filters. This pin must not be left floating. It must be connected to a defined logic state (or GND or V_{S+})
V_{S+}	10	I	Positive power-supply pin; connect to +3 V to +5 V
CH4 OUT	11	O	Video output; channel 4
CH3 OUT	12	O	Video output; channel 3
CH2 OUT	13	O	Video output; channel 2
CH1 OUT	14	O	Video output; channel 1

FUNCTIONAL BLOCK DIAGRAM

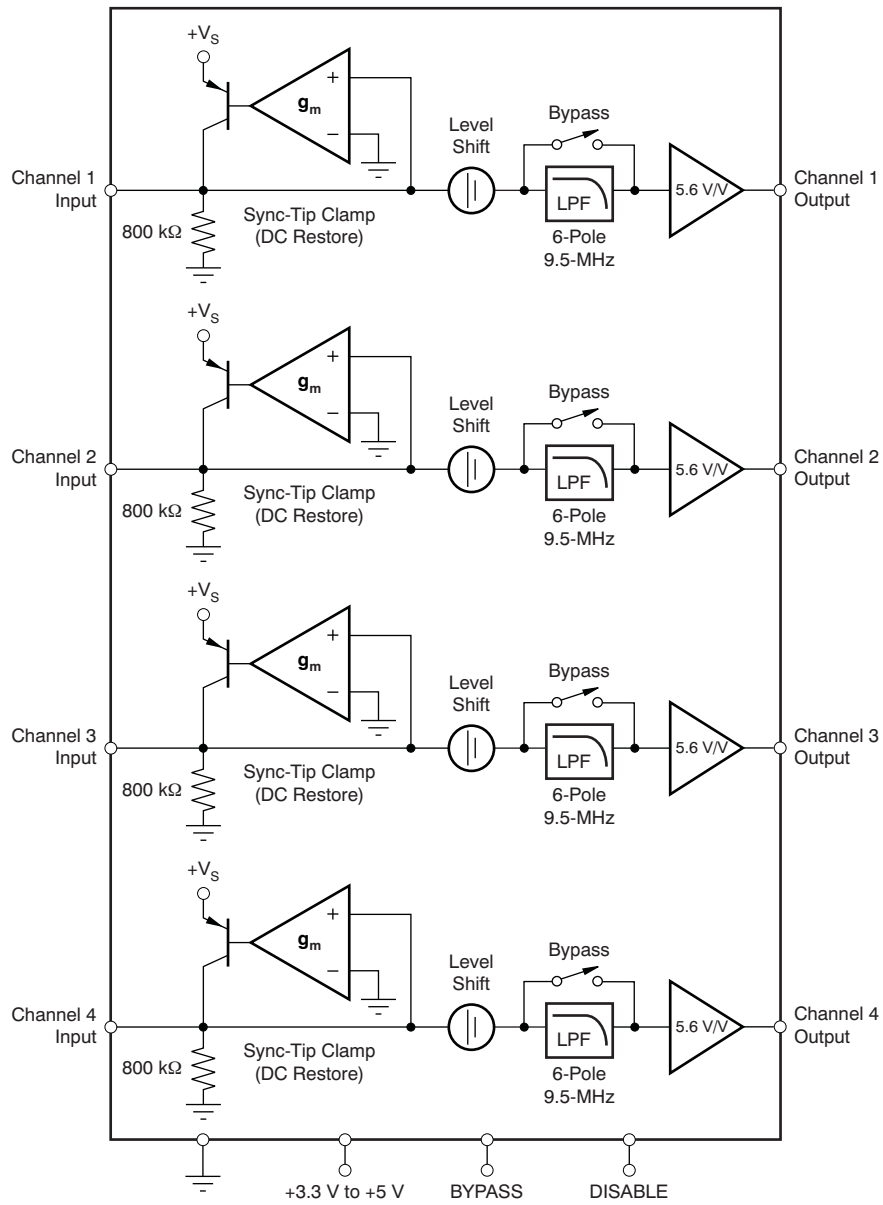

TYPICAL CHARACTERISTICS

$R_L = 150 \Omega$ to GND and dc-coupled input and output, unless otherwise noted.

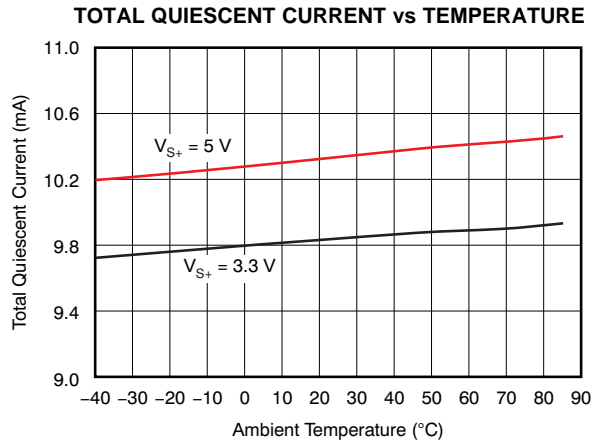

Figure 2.

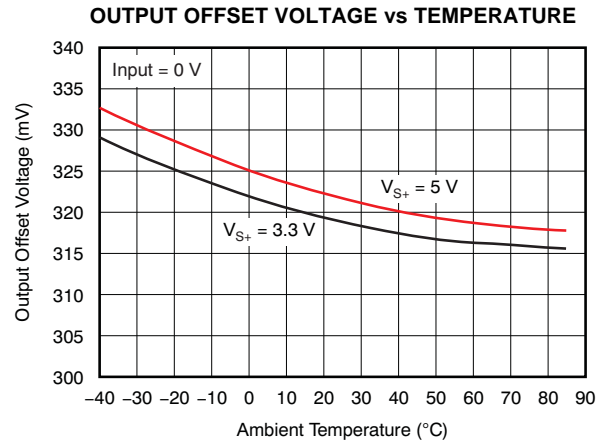

Figure 3.

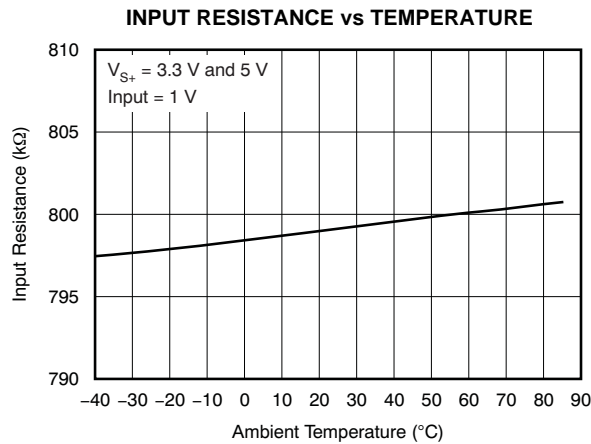

Figure 4.

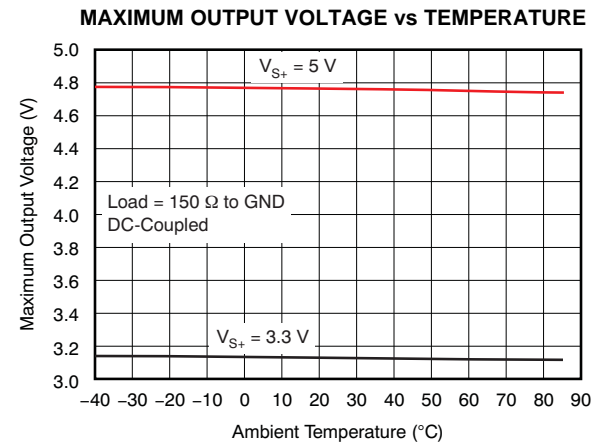

Figure 5.

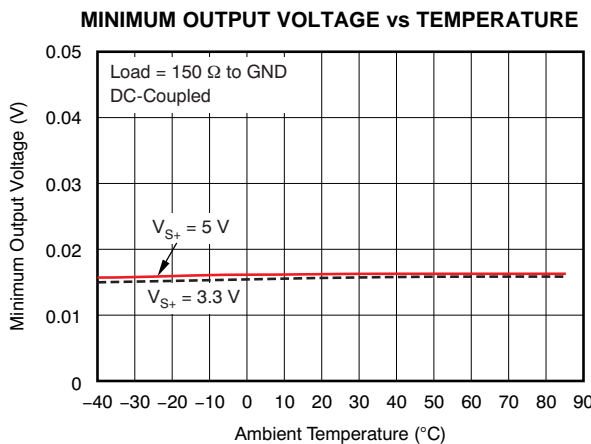

Figure 6.

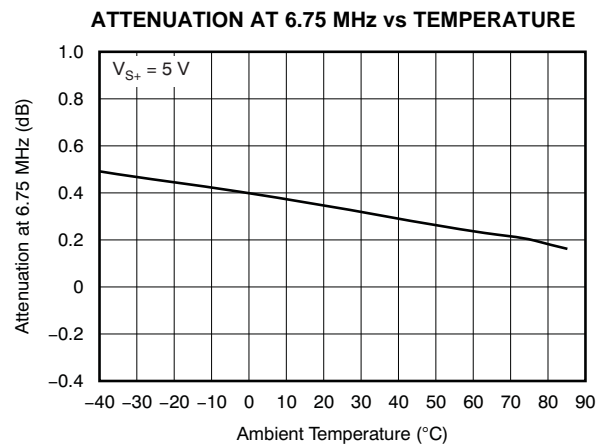
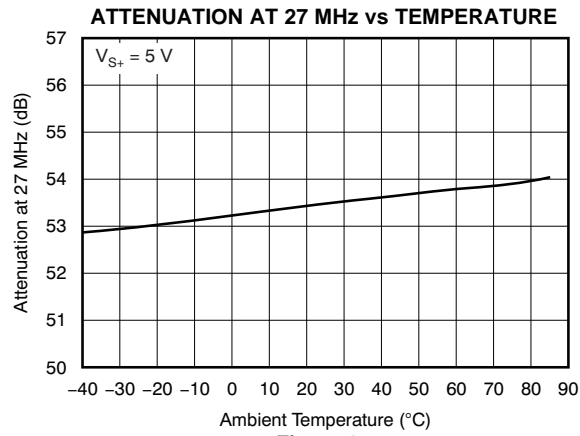

Figure 7.

TYPICAL CHARACTERISTICS (continued)

$R_L = 150 \Omega$ to GND and dc-coupled input and output, unless otherwise noted.



TYPICAL CHARACTERISTICS: $V_{S+} = 3.3\text{ V}$

$R_L = 150\ \Omega$ to GND and dc-coupled input and output, unless otherwise noted.

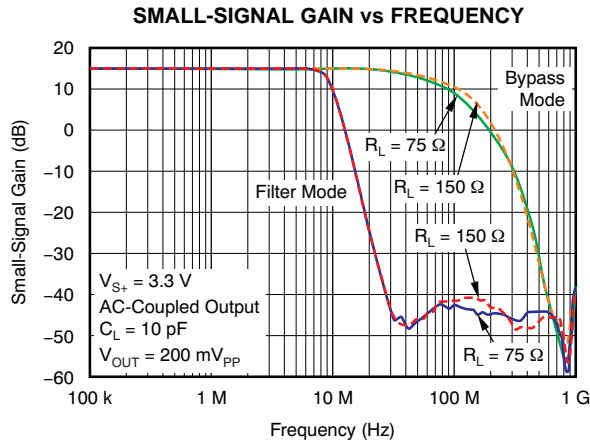

Figure 9.

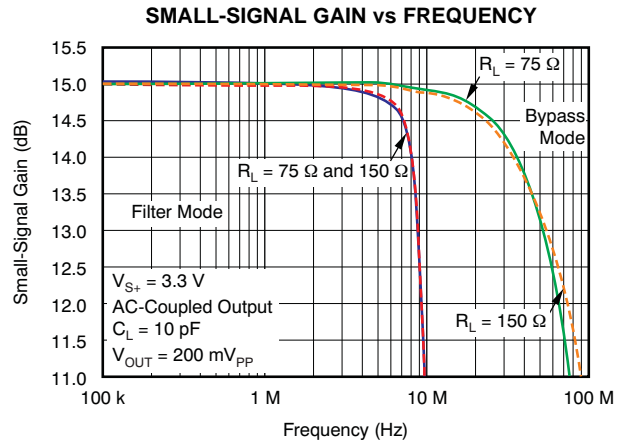

Figure 10.

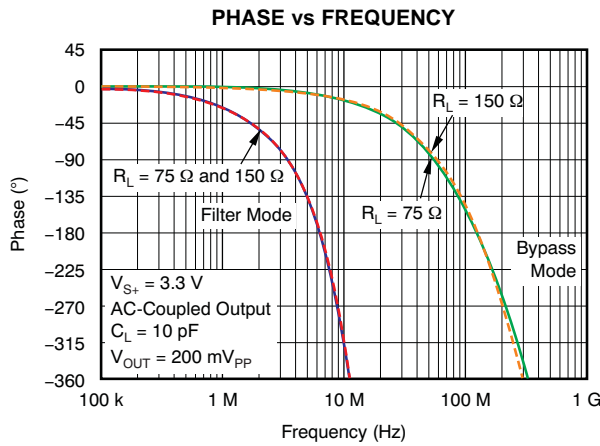

Figure 11.

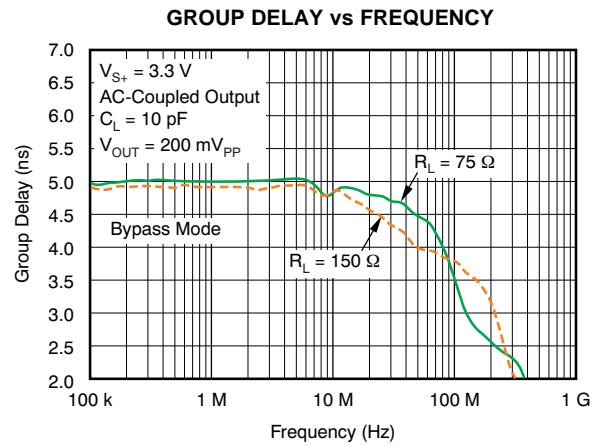

Figure 12.

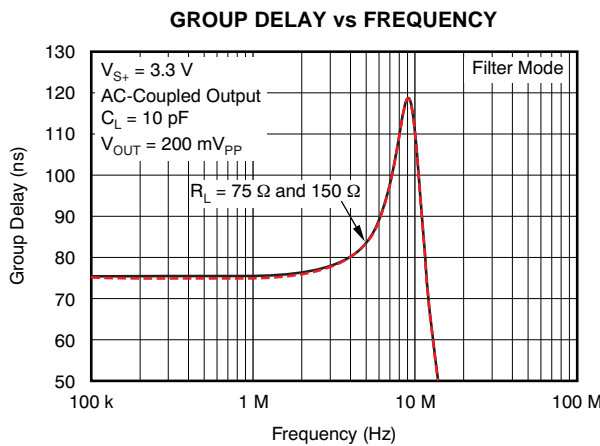

Figure 13.

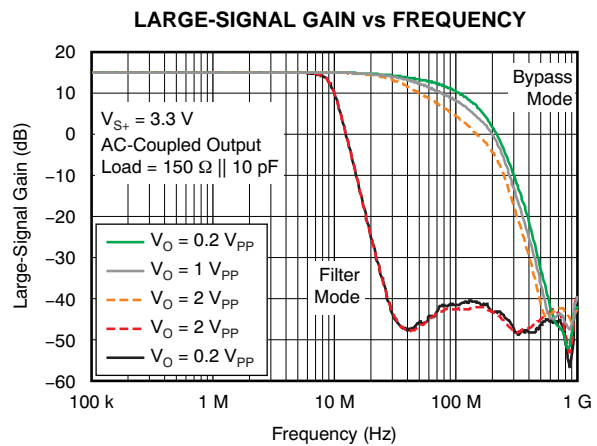

Figure 14.

TYPICAL CHARACTERISTICS: $V_{S+} = 3.3\text{ V}$ (continued)

$R_L = 150\ \Omega$ to GND and dc-coupled input and output, unless otherwise noted.

LARGE-SIGNAL GAIN vs FREQUENCY

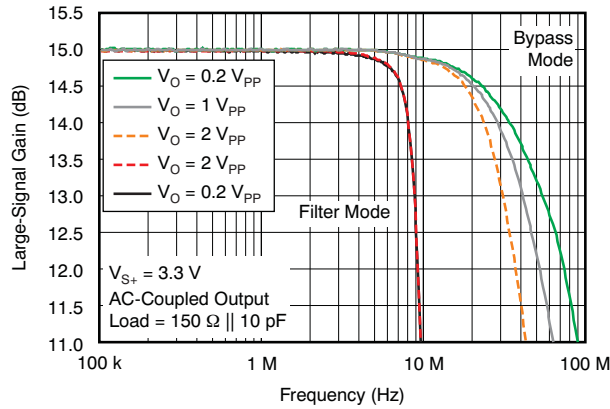

Figure 15.

SMALL-SIGNAL GAIN vs FREQUENCY

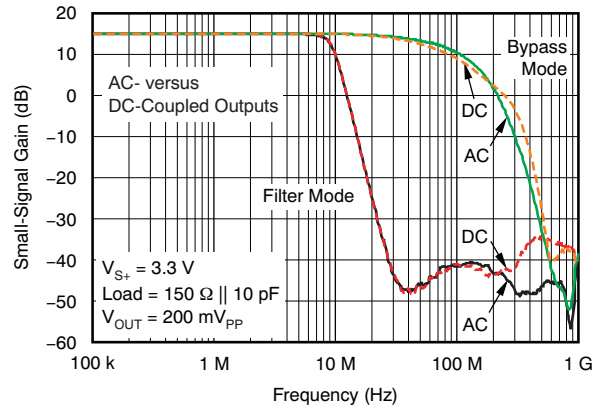

Figure 16.

SMALL-SIGNAL GAIN vs FREQUENCY

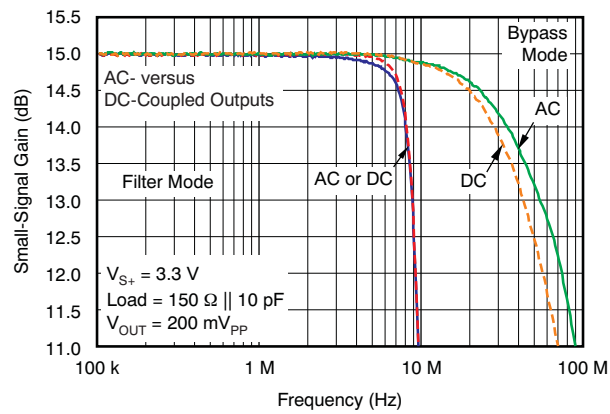

Figure 17.

2ND-ORDER HARMONIC DISTORTION vs OUTPUT VOLTAGE

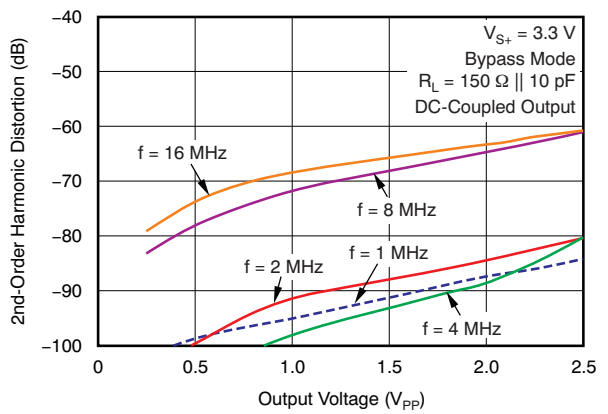

Figure 18.

3RD-ORDER HARMONIC DISTORTION vs OUTPUT VOLTAGE

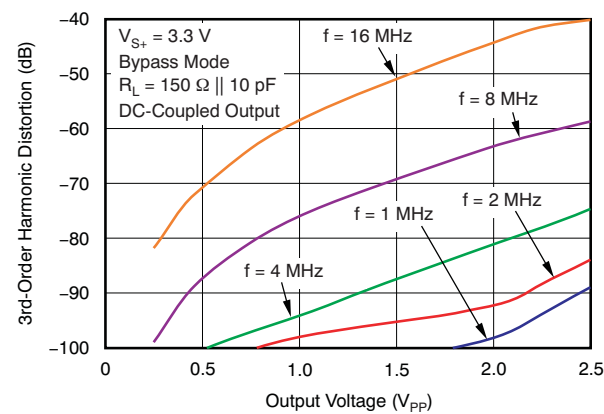

Figure 19.

2ND-ORDER HARMONIC DISTORTION vs OUTPUT VOLTAGE

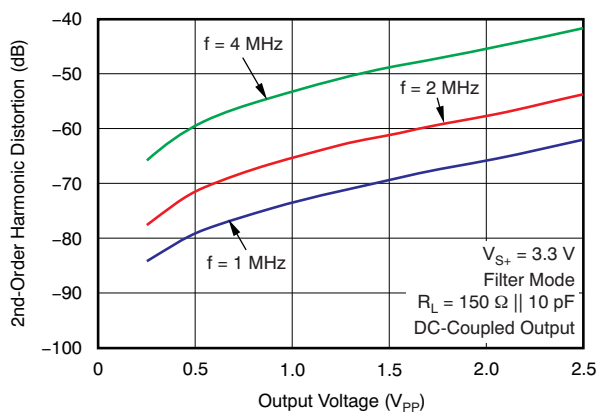

Figure 20.

TYPICAL CHARACTERISTICS: $V_{S+} = 3.3\text{ V}$ (continued)

$R_L = 150\ \Omega$ to GND and dc-coupled input and output, unless otherwise noted.

3RD-ORDER HARMONIC DISTORTION vs OUTPUT VOLTAGE

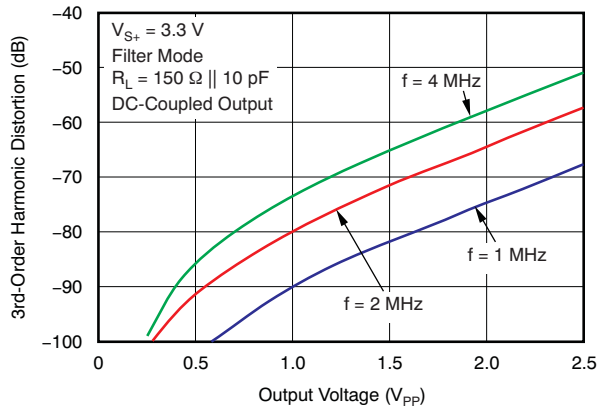

Figure 21.

2ND-ORDER HARMONIC DISTORTION vs OUTPUT VOLTAGE

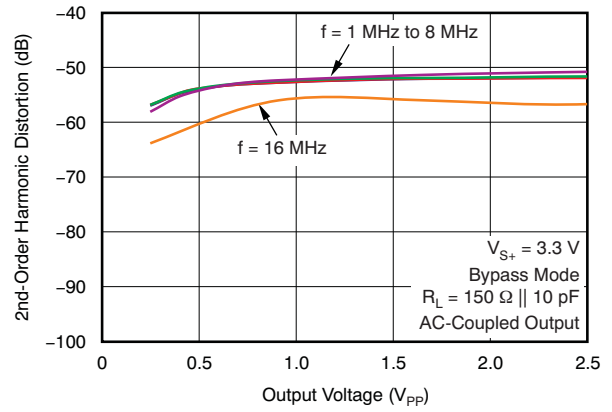

Figure 22.

3RD-ORDER HARMONIC DISTORTION vs OUTPUT VOLTAGE

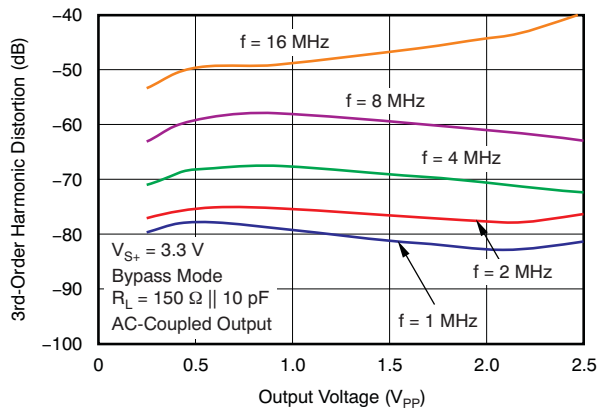

Figure 23.

2ND-ORDER HARMONIC DISTORTION vs OUTPUT VOLTAGE

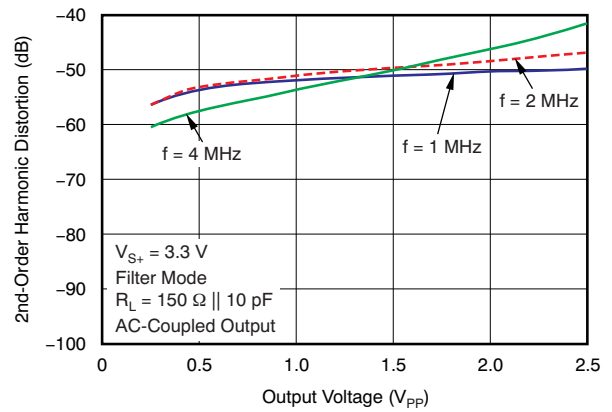

Figure 24.

3RD-ORDER HARMONIC DISTORTION vs OUTPUT VOLTAGE

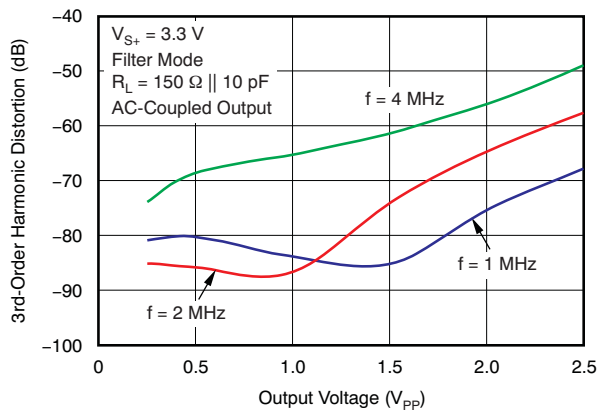

Figure 25.

OUTPUT IMPEDANCE vs FREQUENCY

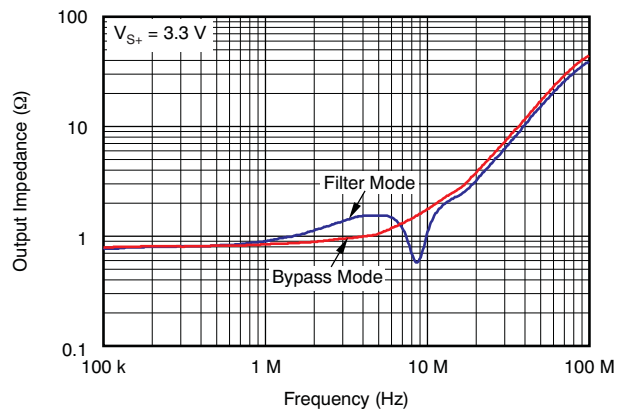
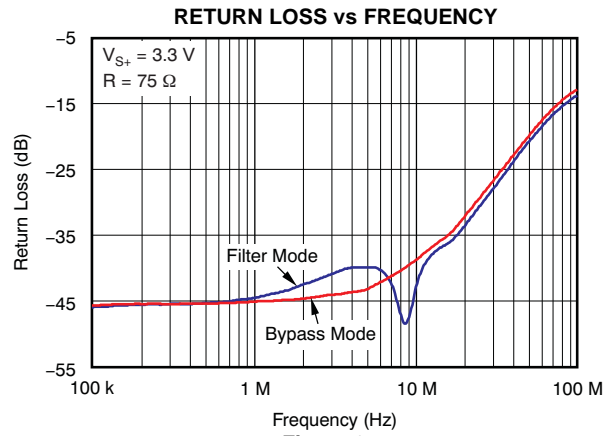

Figure 26.

TYPICAL CHARACTERISTICS: $V_{S+} = 3.3\text{ V}$ (continued)

$R_L = 150\ \Omega$ to GND and dc-coupled input and output, unless otherwise noted.



TYPICAL CHARACTERISTICS: $V_{S+} = 5\text{ V}$

$R_L = 150\ \Omega$ to GND and dc-coupled input and output, unless otherwise noted.

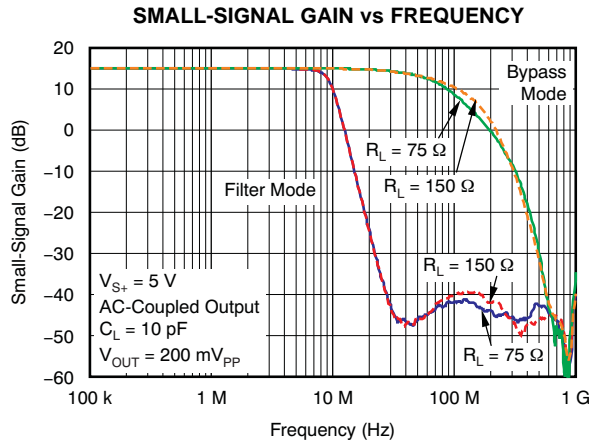

Figure 28.

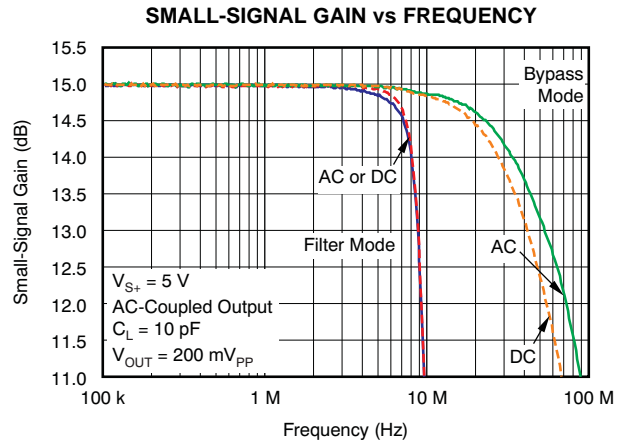

Figure 29.

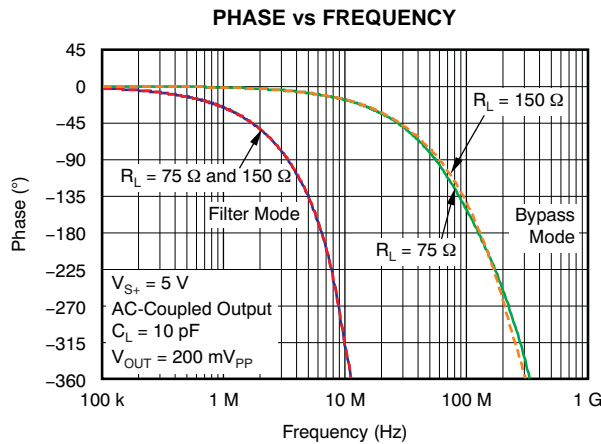

Figure 30.

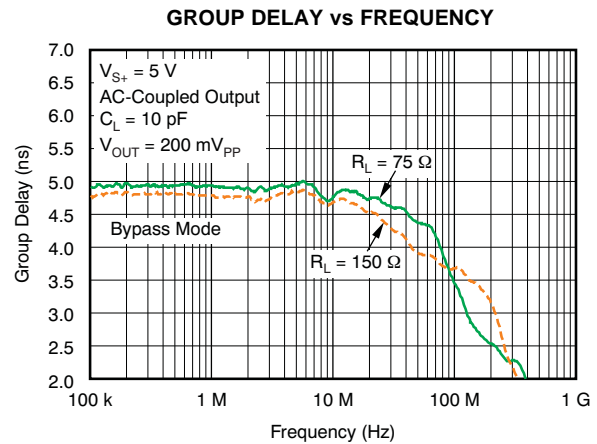

Figure 31.

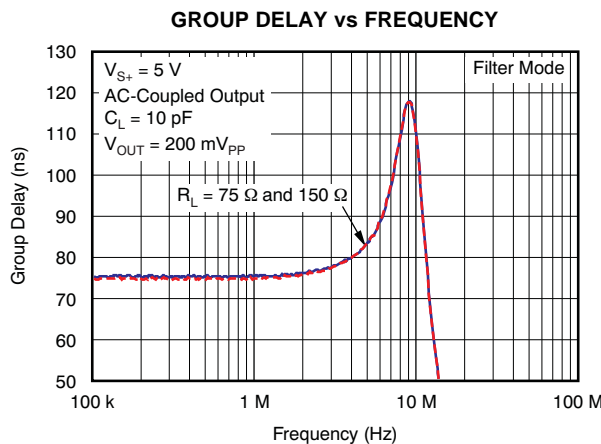

Figure 32.

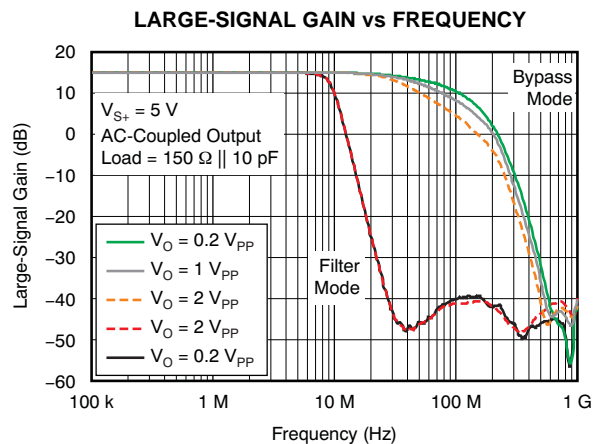

Figure 33.

TYPICAL CHARACTERISTICS: $V_{S+} = 5\text{ V}$ (continued)

$R_L = 150\ \Omega$ to GND and dc-coupled input and output, unless otherwise noted.

LARGE-SIGNAL GAIN vs FREQUENCY

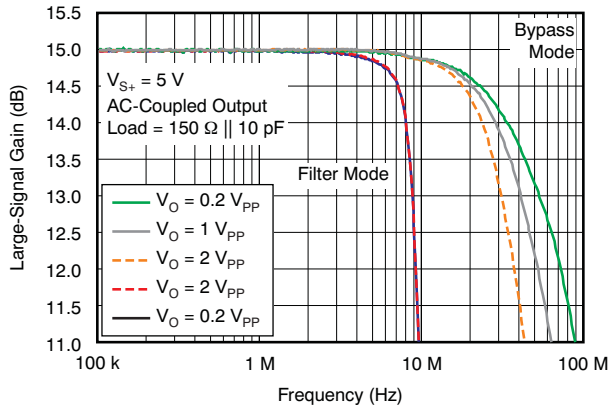

Figure 34.

SMALL-SIGNAL GAIN vs FREQUENCY

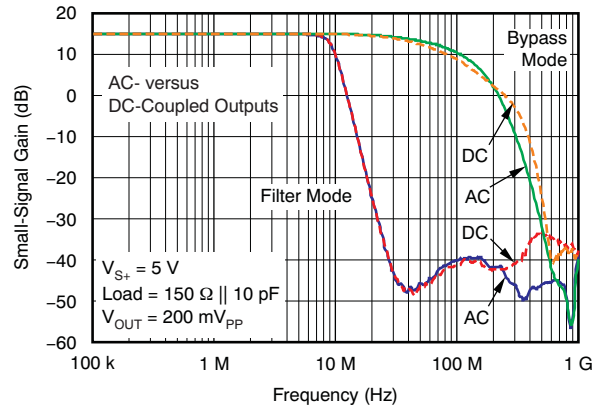

Figure 35.

SMALL-SIGNAL GAIN vs FREQUENCY

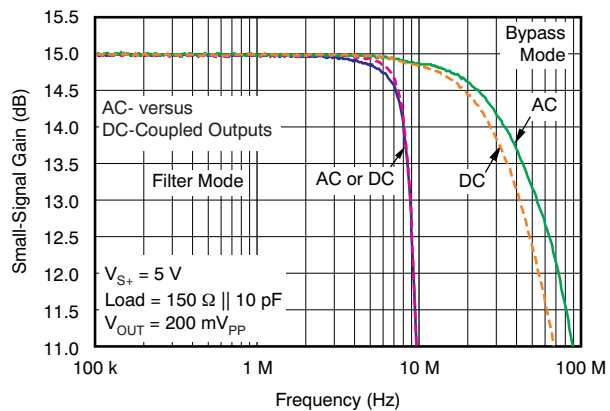

Figure 36.

2ND-ORDER HARMONIC DISTORTION vs OUTPUT VOLTAGE

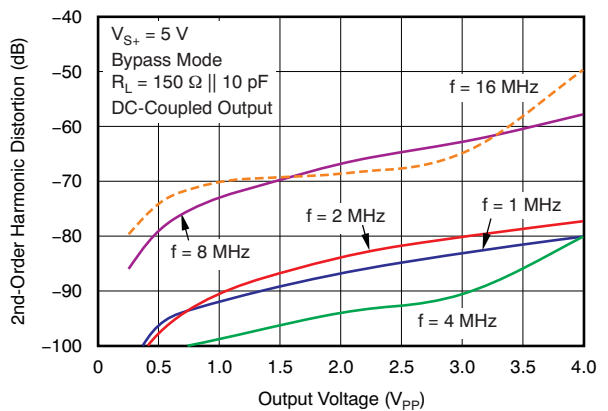

Figure 37.

3RD-ORDER HARMONIC DISTORTION vs OUTPUT VOLTAGE

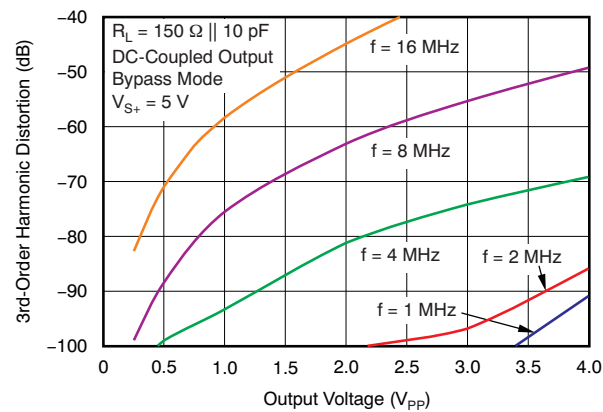

Figure 38.

2ND-ORDER HARMONIC DISTORTION vs OUTPUT VOLTAGE

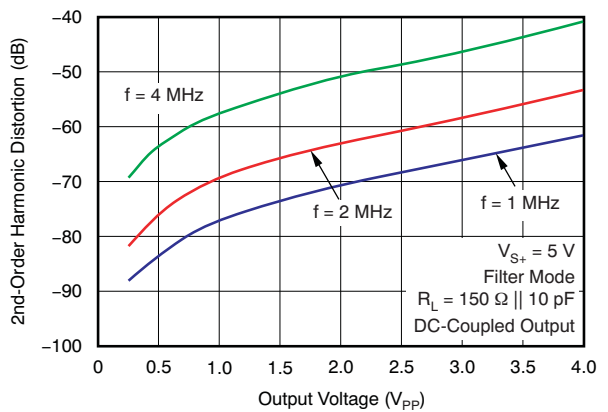

Figure 39.

TYPICAL CHARACTERISTICS: $V_{S+} = 5\text{ V}$ (continued)

$R_L = 150\ \Omega$ to GND and dc-coupled input and output, unless otherwise noted.

3RD-ORDER HARMONIC DISTORTION vs OUTPUT VOLTAGE

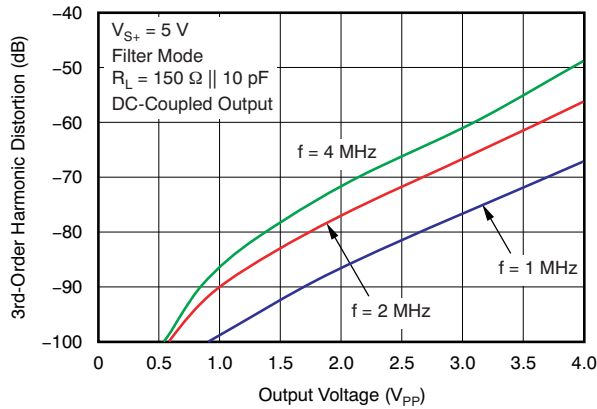

Figure 40.

2ND-ORDER HARMONIC DISTORTION vs OUTPUT VOLTAGE

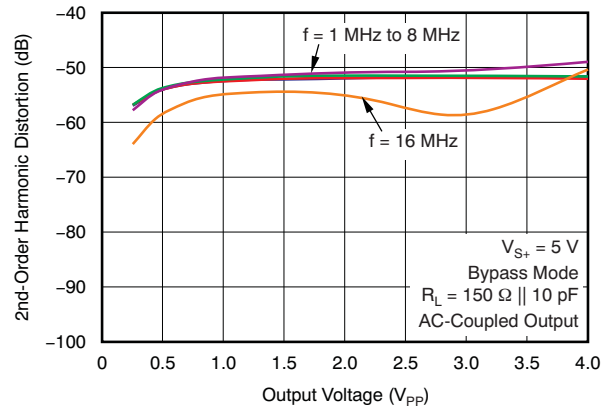

Figure 41.

3RD-ORDER HARMONIC DISTORTION vs OUTPUT VOLTAGE

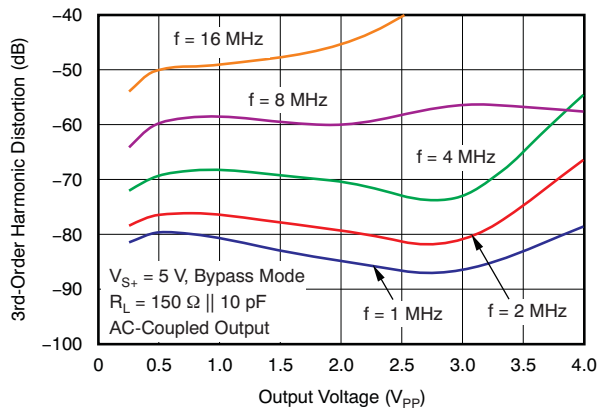

Figure 42.

2ND-ORDER HARMONIC DISTORTION vs OUTPUT VOLTAGE

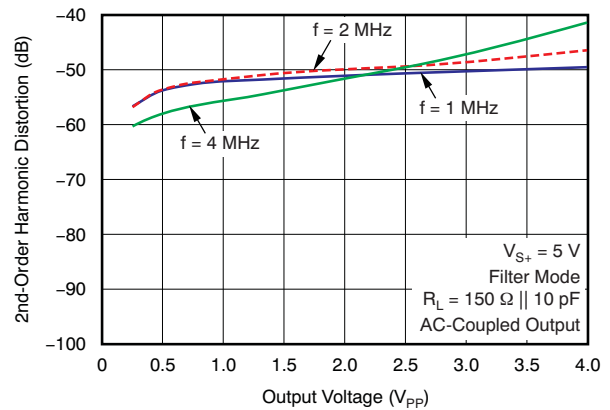

Figure 43.

3RD-ORDER HARMONIC DISTORTION vs OUTPUT VOLTAGE

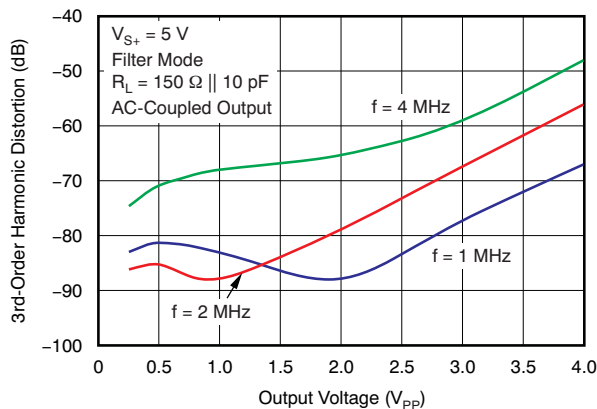

Figure 44.

OUTPUT IMPEDANCE vs FREQUENCY

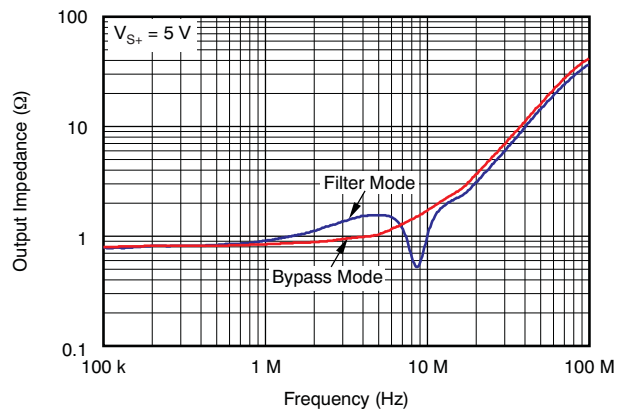
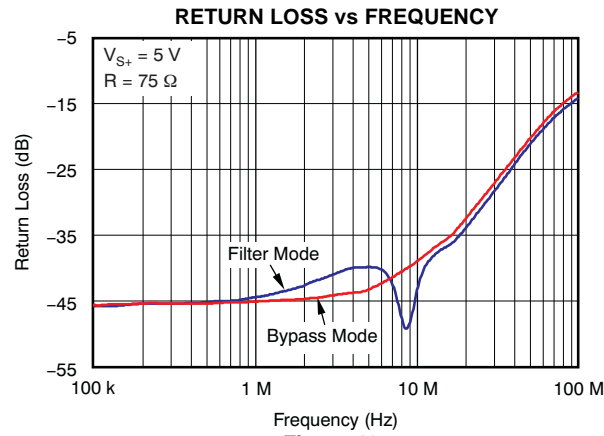

Figure 45.

TYPICAL CHARACTERISTICS: $V_{S+} = 5\text{ V}$ (continued)

$R_L = 150\ \Omega$ to GND and dc-coupled input and output, unless otherwise noted.



APPLICATION INFORMATION

The THS7375 is targeted for standard definition video output buffer applications. Although it can be used for numerous other applications, the needs and requirements of the video signal are the most important design parameters of the THS7375. Built on the revolutionary complementary Silicon Germanium (SiGe) BiCom3X process, the THS7375 incorporates many features not typically found in integrated video parts while consuming very low power. The THS7375 has the following features:

- Single-supply 3-V to 5-V operation with low total quiescent current of 9.8 mA at 3.3 V and 10.3 mA at 5 V.
- Disable mode allows for shutting down the THS7375 to save system power in power-sensitive applications.
- Input configuration accepts dc + level shift, ac sync-tip clamp, or ac-bias.
- AC-biasing is allowed with the use of a single external pull-up resistor to the positive power supply.
- Sixth-order low-pass filter for DAC reconstruction or ADC image rejection:
 - 9.5 MHz for NTSC, PAL, SECAM, composite (CVBS), S-Video Y'C', 480i/576i Y'P_BP_R, G'B'R' (R'G'B'), and SCART signals.
- Bypass mode bypasses the low-pass filter with a 70-MHz bandwidth and 150-V/μs slew rate amplifier
- Internal fixed gain of 5.6 V/V (+14.95 dB) buffer that can drive two video lines per channel with dc-coupling or traditional ac-coupling. This feature is ideal for DaVinci, DM2xx, DM3xx, DM64xx, and OMAP processors.
- Signal flow-through configuration in a TSSOP-14 package that complies with the latest lead-free (RoHS-compatible) and green manufacturing requirements.

OPERATING VOLTAGE

The THS7375 is designed to operate from 3-V to 5-V over a -40°C to $+85^{\circ}\text{C}$ temperature range. The impact on performance over the entire temperature range is negligible as a result of the implementation of thin film resistors and high quality, low temperature coefficient capacitors. The design of the THS7375 allows operation down to 2.85 V, but it is recommended to use at least a 3-V supply to ensure that there are no issues with headroom or clipping.

Place a 0.1-μF to 0.01-μF capacitor as close as possible to the power-supply pins. Failure to do so may result in ringing or oscillating at the THS7375 outputs. Additionally, a large capacitor (22 μF to 100 μF) should be placed on the power-supply line to minimize interference with 50-Hz/60-Hz line frequencies.

INPUT VOLTAGE

The THS7375 input range allows for an input signal range from -0.2 V to approximately $(V_{S+} - 1.5\text{ V})$. However, because of the internal fixed gain of 5.6 V/V (+14.95 dB) and the internal level shift that causes a 320-mV level shift, the output is generally the limiting factor for the allowable linear input range. For example, with a 5-V supply, the linear input range is from -0.2 V to 3.5 V. As a result of the gain and level shift, the linear output range limits the allowable linear input range to be from about -0.1 V to 0.8 V.

INPUT OVERVOLTAGE PROTECTION

The THS7375 is built using a very high-speed complementary bipolar and CMOS process. The internal junction breakdown voltages are relatively low for these very small geometry devices. These breakdowns are reflected in the [Absolute Maximum Ratings](#) table. All input and output device pins are protected with internal ESD protection diodes to the power supplies, as shown in [Figure 47](#).

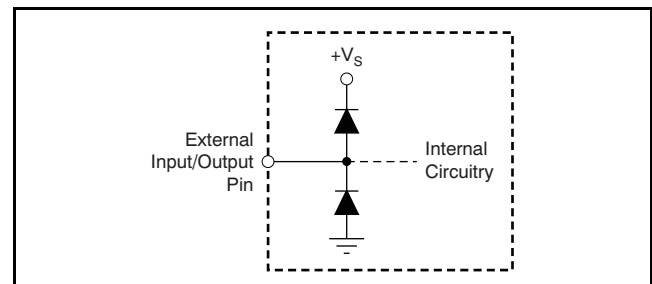

Figure 47. Internal ESD Protection

These diodes provide moderate protection to input overdrive voltages above and below the supplies as well. The protection diodes can typically support 30 mA of continuous current when overdriven.

TYPICAL CONFIGURATION AND VIDEO TERMINOLOGY

A typical application circuit that uses the THS7375 as a video buffer is shown in Figure 48. It shows a DAC or encoder driving the input channels of the THS7375. One channel is a composite video (CVBS) channel of a standard definition (SD) video system. The other channels are the component video $Y'P'_B P'_R$ (sometimes labeled $Y'U'V'$ or incorrectly labeled $Y'C'_B C'_R$) signals of a 480i or 576i system. These channels could easily be the S-Video Y'/C' channels or the $R'G'B'$ channels of a SCART system.

Note that the Y' term is used for the luma channels throughout this document rather than the more common luminance (Y) term. The reason for this usage is to account for the definition of luminance as stipulated by the [International Commission on Illumination \(CIE\)](#). Video departs from true luminance because a nonlinear term, gamma, is added to the true RGB signals to form $R'G'B'$ signals. These $R'G'B'$ signals are then used to mathematically create luma (Y'). Thus, luminance (Y) is not maintained, providing a difference in terminology.

This rationale is also used for the chroma (C') term. Chroma is derived from the nonlinear $R'G'B'$ terms and thus it is also nonlinear. Chrominance (C) is derived from linear RGB, giving the difference between chroma (C') and chrominance (C). The color difference signals ($P'_B/P'_R/U'V'$) are also referenced in this way to denote the nonlinear (gamma corrected) signals.

$R'G'B'$ (commonly mislabeled RGB) is also called $G'B'R'$ (again commonly mislabeled as GBR) in professional video systems. The SMPTE component standard stipulates that the luma information is placed on the first channel, the blue color difference is placed on the second channel, and the red color difference signal is placed on the third channel. This configuration is consistent with the $Y'P'_B P'_R$ nomenclature. Because the luma channel (Y') carries the sync information and the green channel (G') also carries the sync information, it makes logical sense that G' be placed first in the system. Furthermore, because the blue color difference channel (P'_B) is next and the red color difference channel (P'_R) is last, then it also makes logical sense to place the B' signal on the second channel and the R' signal on the third channel respectfully. Thus, hardware compatibility is better achieved when using $G'B'R'$ rather than $R'G'B'$. Note that for many $G'B'R'$ systems, sync is embedded on all three channels, but this configuration may not always be the case in all systems.

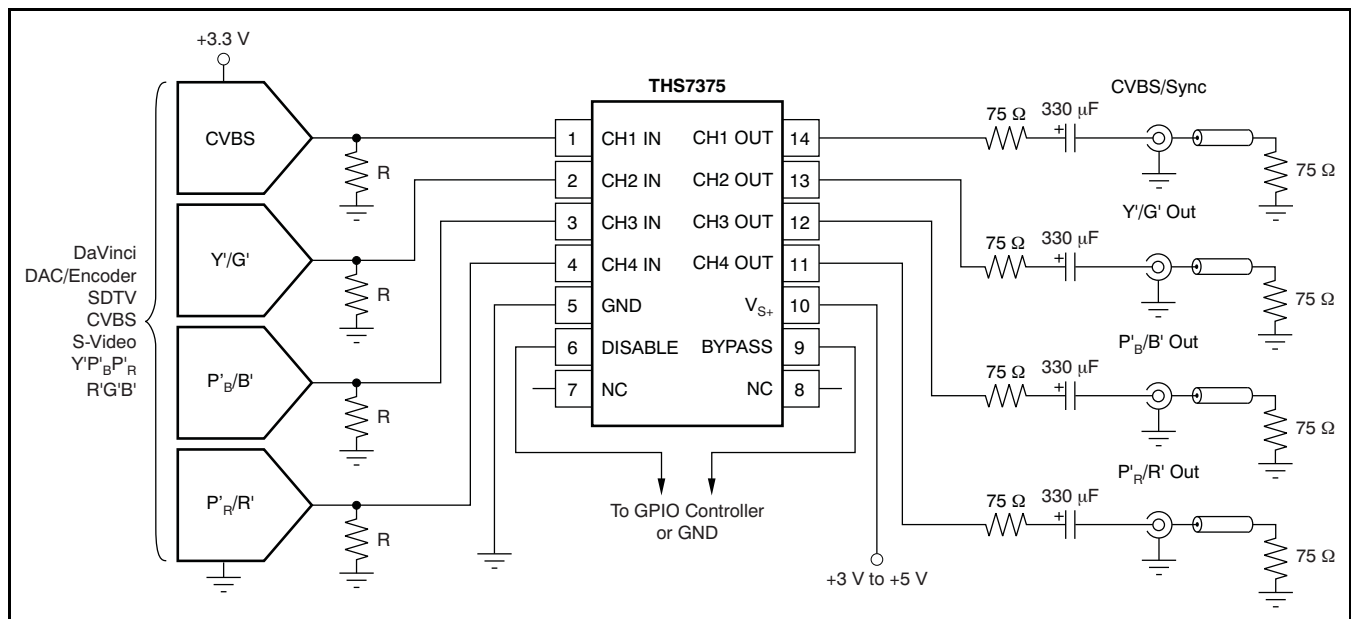

Figure 48. Typical SDTV CVBS/ $Y'P'_B P'_R$ Inputs from DC-Coupled Encoder/DAC with AC-Coupled Line Driving

INPUT MODE OF OPERATION: DC

The THS7375 allows for both ac-coupled and dc-coupled inputs. Many DACs or video encoders can be dc-connected to the THS7375. One of the drawbacks to dc coupling, however, is when 0 V is applied to the input. Although the input of the THS7375 allows for a 0-V input signal with no issues, the output swing of a traditional amplifier cannot yield a 0-V signal, resulting in possible clipping. This condition is true for any single-supply amplifier as a result of output transistor limitations. Both CMOS and bipolar transistors cannot go to 0 V while sinking current. This characterization of a transistor is also the same reason why the highest output voltage is always less than the power-supply voltage when sourcing current.

This output clipping can reduce the sync amplitudes (both horizontal and vertical sync) on the video signal. A problem occurs if the receiver of this video signal uses an AGC loop to account for losses in the transmission line. Some video AGC circuits derive gain from the horizontal sync amplitude. If clipping occurs on the sync amplitude, then the AGC circuit can increase the gain too much—resulting in too much luma and/or chroma amplitude gain correction. This overcorrection may result in a picture with an overly bright display with too much color saturation.

Other AGC circuits use the chroma burst amplitude for amplitude control, and a reduction in the sync signals does not alter the proper gain setting. However, it is good engineering design practice to ensure that saturation/clipping does not take place. Transistors always take a finite amount of time to come out of saturation. This saturation could possibly result in timing delays or other aberrations on the signals.

To eliminate saturation/clipping problems, the THS7375 has a 320-mV output level shift feature. This feature takes the input voltage and adds an internal shift to the signal. The THS7375 rail-to-rail output stage can create this output level while connected to a typical video load. This feature ensures that no saturation/clipping of the sync signals occur. This shift is constant, regardless of the input signal. For example, if a 0.4-V input is applied, the output is at $(0.4 \text{ V} \times 5.6 \text{ V/V}) + 0.32 \text{ V} = 2.56 \text{ V}$.

Because the internal gain is fixed at 5.6 V/V (+14.95 dB), the gain dictates what the allowable linear input voltage range can be without clipping concerns. For example, if the power supply is set to 3.3 V, the maximum output is approximately 3.15 V while driving a significant amount of current. Thus, to avoid clipping, the allowable input is $[(3.2 \text{ V} - 0.32 \text{ V}) / 5.6$

$\text{V/V}] = 0.51 \text{ V}$. This calculation is true for up to the maximum recommended 5-V power supply that allows approximately a $[(4.9 \text{ V} - 0.32 \text{ V}) / 5.6 \text{ V/V}] = 0.818 \text{ V}$ input range while avoiding clipping on the output.

The input impedance of the THS7375 in this mode of operation is dictated by the internal 800-k Ω pull-down resistor, as shown in Figure 49. Note that the internal voltage shift does not appear at the input pin, but only the output pin.

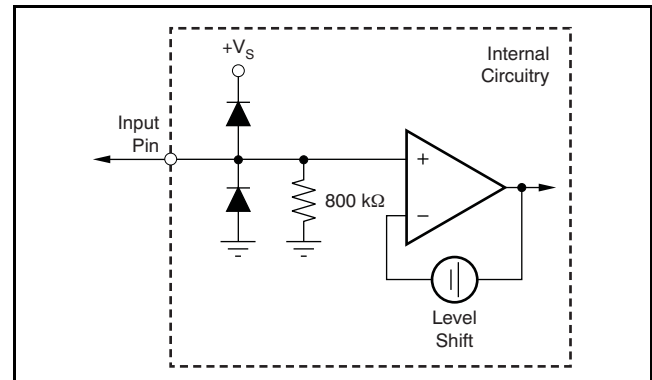

Figure 49. Equivalent DC Input Mode Circuit

INPUT MODE OF OPERATION: AC SYNC-TIP CLAMP

Some video DACs or encoders are not referenced to ground but rather to the positive power supply. The resulting video signals are generally at too high of a voltage for a dc-coupled video buffer to function properly. To account for this scenario, the THS7375 incorporates a sync-tip clamp (STC) circuit. This function requires a capacitor (nominally 0.1 μF) to be in series with the input. Note that while the term *sync-tip clamp* is used throughout this document, it should be noted that the THS7375 would probably be better termed to be a *dc restoration circuit* based on how this function is performed. This circuit is an active clamp circuit and not a passive diode clamp function.

The input to the THS7375 has an internal control loop that sets the lowest input applied voltage to clamp at ground (0 V). By setting the reference at 0 V, the THS7375 allows a dc-coupled input to also function. Therefore, the STC is considered transparent because it does not operate unless the input signal goes below ground. The signal then goes through the same level shifter, resulting in an output voltage low level of 320 mV. If the input signal tries to go below 0 V, the internal control loop of the THS7375 sources up to 3 mA of current to increase the input voltage level on the THS7375 input side of the coupling capacitor. As soon as the voltage goes above the 0-V level, the loop stops sourcing current and becomes very high impedance.

One of the concerns about the sync tip clamp level is how the clamp reacts to a sync edge that has overshoot—common in VCR signals or reflections found in poor printed circuit board (PCB) layouts. Ideally, the STC should not react to the overshoot voltage of the input signal. Otherwise, this issue could result in clipping on the remainder of the video signal because it may raise the bias voltage too much.

To help minimize this input signal overshoot problem, the control loop in the THS7375 has an internal low-pass filter as shown in Figure 50. This filter reduces the response time of the STC circuit. This delay is a function of how far the voltage is below ground, but in general it is close to an 800-ns delay. This filter slows down the response of the control loop so as not to clamp on the input overshoot voltage, but rather the flat portion of the sync signal.

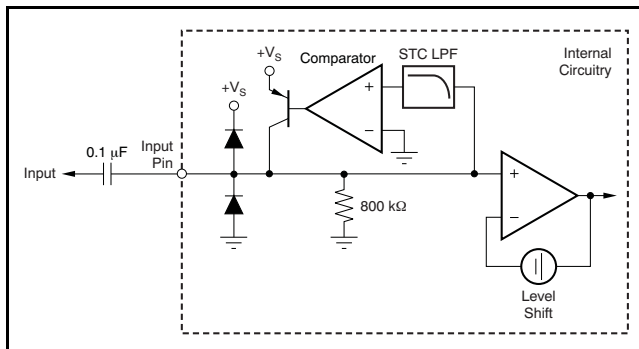

Figure 50. Equivalent AC Sync-Tip Clamp Input Circuit

As a result of this delay, the sync may have an apparent voltage shift. The amount of shift depends on the amount of droop in the signal as dictated by the input capacitor and the STC current flow. Because the sync is primarily for timing purposes, with synchronization occurring on the edge of the sync signal, this shift is transparent in most systems.

While this feature may not fully eliminate overshoot issues on the input signal in case of severe overshoot and/or ringing, the STC system should help minimize improper clamping levels. As an additional method to help minimize this issue, an external capacitor (such as 10 pF to 47 pF) to ground in parallel with the external termination resistors can help filter overshoot problems.

It should be noted that this STC system is dynamic and does not rely upon timing in any way. It only depends on the voltage that appears at the input pin at any given point in time. The STC filtering helps minimize level shift problems associated with switching noises or very short spikes on the signal line. This feature helps ensure a very robust STC system.

When the ac STC operation is used, there must also be some finite amount of discharge bias current. As previously described, if the input signal goes below the 0-V clamp level, the internal loop of the THS7375 sources current to increase the voltage appearing at the input pin. As the difference between the signal level and the 0-V reference level increases, the amount of source current increases proportionally—supplying up to 3 mA of current. Thus, the time period to re-establish the proper STC voltage can be very short. If the difference is very small, then the source current is also very small to account for minor voltage droop.

However, if the input signal goes above the 0-V input level, a problem arises. The problem is that the video signal is always above this level and must not be altered in any way. But if the sync level of the input signal is above this 0-V level, then the internal discharge (sink) current reduces the ac-coupled bias signal to the proper 0-V level.

This discharge current must not be large enough to alter the video signal appreciably or picture quality issues may arise. This issue is often seen by looking at the tilt (droop) of a constant luma signal being applied and observing the resulting output level. The associated change in luma level from the beginning of the video line to the end of the video line is the amount of line tilt (droop).

If the discharge current is very small, then the amount of tilt is very low, which is generally a good thing. However, the amount of time for the system to capture the sync signal could be too long. This effect is also called *hum rejection*. Hum arises from the ac line voltage frequency of 50-Hz or 60-Hz. The value of the discharge current and the ac-coupling capacitor combine to dictate the hum rejection and the amount of line tilt.

To allow for both dc-coupling and ac-coupling in the same part, the THS7375 incorporates an 800-kΩ resistor to ground. Although a true constant-current sink is preferred over a resistor, there are significant issues when the voltage is near ground. This condition can cause the current sink transistor to saturate and cause potential problems with the signal. Also, this resistor is large enough to not impact a dc-coupled DAC termination. For discharging an ac-coupled source, Ohm's Law is applied. If the video signal is 1 V, then there is $1\text{ V}/800\text{ k}\Omega = 1.25\text{ }\mu\text{A}$ of discharge current. If more hum rejection is desired or there is a loss of sync occurring, simply decrease the 0.1-μF input coupling capacitor. A decrease from 0.1 μF to 0.047 μF increases the hum rejection by a factor of 2:1. Alternatively, an external pull-down resistor to ground may be added that decreases the overall resistance and ultimately increases the discharge current.

To ensure proper stability of the ac STC control loop, the source impedance must be less than 1 kΩ with the input capacitor in place. Otherwise, there is a possibility for the control loop to ring; this ringing may appear on the THS7375 output. Because most DACs or encoders use resistors to establish the voltage, which are typically less than 500 Ω, meeting the less than 1-kΩ requirement is easily done. However, if the source impedance looking from the THS7375 input perspective is very high, simply adding a 1-kΩ resistor to GND ensures proper operation of the THS7375.

INPUT MODE OF OPERATION: AC BIAS

Sync-tip clamps are ideal for signals that have horizontal and/or vertical syncs associated with them. However, some video signals do not have a sync embedded within the signal. If ac-coupling of these signals is desired, then a dc bias is required to properly set the dc operating point within the THS7375. This function is easily accomplished with the THS7375 by simply adding an external pull-up resistor to the positive power supply, as shown in Figure 51.

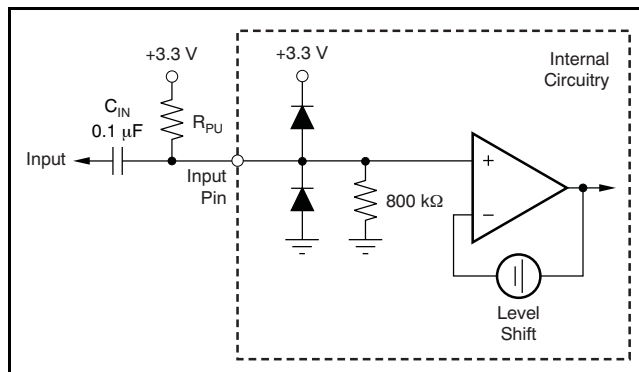

Figure 51. AC-Bias Input Mode Circuit Configuration

The dc voltage that appears at the input pin is equal to Equation 1:

$$V_{DC} = V_S \left[\frac{800 \text{ k}\Omega}{800 \text{ k}\Omega + R_{PU}} \right] \quad (1)$$

The THS7375 allowable input range is approximately ($V_{S+} - 1.5 \text{ V}$), which allows for a very wide input voltage range but is limited by the allowable output voltage range and the internal gain. As such, the input dc bias point is very flexible; the output dc bias point is the primary factor. For example, if the output dc bias point is desired to be 1.6 V on a 3.3-V supply, then the input dc bias point is recommended to be

$(1.6 \text{ V} - 320 \text{ mV})/5.6 = 0.228 \text{ V}$. Thus, the pull-up resistor calculates to approximately 10.8 MΩ. If the output dc-bias point is desired to be 1.6 V with a 5-V power supply, then the value calculates to be approximately 16.7 MΩ.

Keep in mind that the internal 800-kΩ resistor has a $\pm 20\%$ variance. As such, the calculations should take this variance into account. For the 0.228-V input bias voltage example above using an ideal 10.8-MΩ resistor, the input dc bias voltage is about 0.228 V ($\pm 0.045 \text{ V}$) which translates to an output bias voltage of about 1.6 V ($\pm 0.25 \text{ V}$).

If desired, an external resistor can be placed in parallel with the internal 800-kΩ resistor. This external resistor may be required if the pull-up resistor calculates to a value higher than desired. There are no consequences of this configuration other than decreasing the effective input impedance of the THS7375 system.

The value of the output bias voltage is very flexible and is left to each individual design. It is important to ensure that the signal does not clip or saturate the video signal. Thus, it is recommended to ensure the output bias voltage is between 0.9 V and ($V_{S+} - 1 \text{ V}$). For 100% color saturated CVBS or signals with Macrovision, the CVBS signal can reach up to 1.23 V_{PP} at the input, or 2.46 V_{PP} at the output of the THS7375. In contrast, other signals are typically 1 V_{PP} or 0.7 V_{PP} at the input which translate to an output voltage of 2 V_{PP} or 1.4 V_{PP} , respectively. The output bias voltage must account for a worst-case situation depending on the signals involved.

One other issue that must be taken into account is the dc-bias point as a function of the power supply. As such, there is an impact on the system PSRR. To help reduce this impact, the input capacitor combines with the pull-up resistance to function as a low-pass filter. Additionally, the time to charge the capacitor to the final dc bias point is also a function of the pull-up resistor and the input capacitor. Lastly, the input capacitor forms a high-pass filter with the parallel impedance of the pull-up resistor and the 800-kΩ resistor. In general, it is good to have this high-pass filter at approximately 3-Hz to minimize any potential droop on a P'_B , P'_R , or non-sync B' or R' signal. A 0.1-μF input capacitor with a 10.8-MΩ pull-up resistor equates to a 2.1-Hz high-pass corner frequency.

This mode of operation is recommended for use with chroma (C'), P'_B , P'_R , U' , V' , and non-sync $R'G'B'$ signals. This method can also be used with signals with sync, if desired. The benefit of using the STC function is that it maintains a constant back-porch voltage as opposed to a back-porch voltage that

fluctuates depending on the video content. Because the corner frequency of the input is a very low 2.5 Hz, the corner frequency of the input is also a very low 2.5 Hz, which is respectable performance relative to a STC configuration.

**OUTPUT MODE OF OPERATION:
DC-COUPLED**

The THS7375 incorporates a rail-to-rail output stage that can be used to drive the line directly without the need for large ac coupling capacitors, as shown in Figure 52. This approach offers the best line tilt and field tilt (or droop) performance because no ac coupling occurs. Keep in mind that if the input is ac-coupled, then the resulting tilt because of the input ac coupling is seen on the output regardless of the output coupling. The 80-mA output current drive capability of the THS7375 was designed to drive two video lines simultaneously (essentially, a 75-Ω load) while maintaining as wide an output dynamic range as possible.

One concern of dc coupling, however, arises if the line is terminated to ground. If the ac-bias input configuration is used, the output of the THS7375 has a dc bias on the output. With two lines terminated to ground, this configuration creates a dc current path that results in a slightly decreased high output voltage

swing and an increase in power dissipation of the THS7375. While the THS7375 was designed to operate with a junction temperature of up to +125°C, care must be taken to ensure that the junction temperature does not exceed this level; otherwise, long-term reliability could suffer. Although this configuration only adds less than 10 mW of power dissipation per channel, the overall low-power dissipation of the THS7375 design minimizes potential thermal issues even when using the TSSOP package at high ambient temperatures.

Note that the THS7375 can drive the line with dc coupling regardless of the input mode of operation. The only requirement is to make sure the video line has proper termination in series with the output—typically 75-Ω. This termination helps isolate capacitive loading effects from the THS7375 output. Failure to isolate capacitive loads may result in instabilities with the output buffer, potentially causing ringing or oscillations to appear. The stray capacitance appearing directly at the THS7375 output pins should be kept below 22-pF. The best way to ensure this limit is maintained is to place the 75-Ω series output resistor as close as possible to the output pin. If an output capacitor is used, as discussed in the next section, then it should be placed after the resistor.

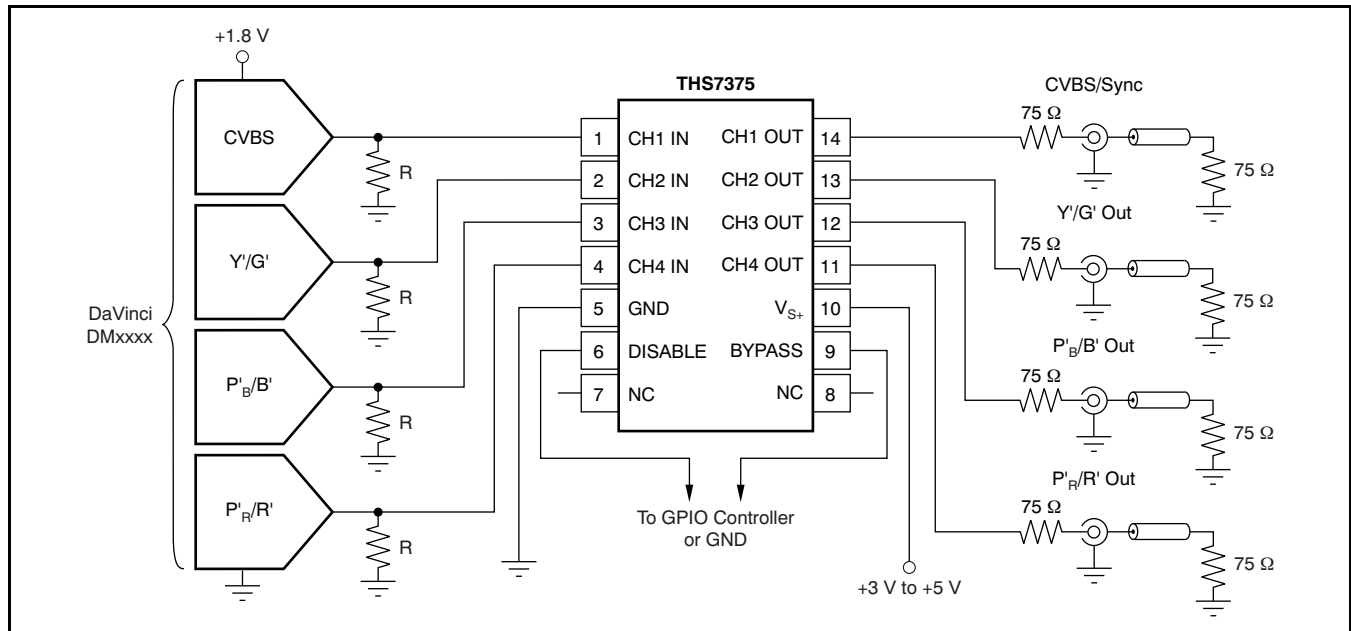

Figure 52. Typical SDTV System with DC-Coupled Line Driving

OUTPUT MODE OF OPERATION: AC-COUPLED

A very common method of coupling the video signal to the line is the use of a large capacitor. This capacitor is typically between 220 μF and 1000 μF , although 470 μF is very common. The value of this capacitor must be large enough to minimize the line tilt (droop) and/or field tilt associated with ac coupling as described previously in this document. AC coupling is done for several reasons, but most often to ensure full interoperability with the receiving video system. AC coupling also ensures adherence to video standard specifications. It ensures that regardless of the reference dc voltage used on the transmit side, the receive side re-establishes the dc reference voltage to its own requirements.

As with the dc output mode of operation discussed previously, each line should have a 75- Ω source termination resistor in series with the ac coupling capacitor. If two lines are to be driven, it is best to have each line use its own capacitor and resistor rather than sharing these components, as shown in Figure 53.

This configuration helps ensure line-to-line dc isolation and avoids the potential problems discussed above. Using a single 1000- μF capacitor for two lines can be done, but there is a chance for interference to be created between the two receivers.

Lastly, because of the edge rates and frequencies of operation, it is recommended (but not required) to place a 0.1- μF to 0.01- μF capacitor in parallel with the large 220- μF to 1000- μF capacitor. These large-value capacitors are generally aluminum electrolytic. It is well-known that these capacitors have significantly large equivalent series resistance (ESR), and the impedance at high frequencies is rather large because of the associated inductances involved with the leads and construction. The small 0.1- μF to 0.01- μF capacitors help pass these high-frequency (> 1-MHz) signals with much lower impedance than the large capacitors.

Although it is common to use the same capacitor values for all the video lines, the frequency bandwidth of the chroma signal in a S-Video system are not required to go as low (or as high of a frequency) as the luma channels. Thus, the capacitor values of the chroma line(s) can be smaller, such as 0.1 μF .

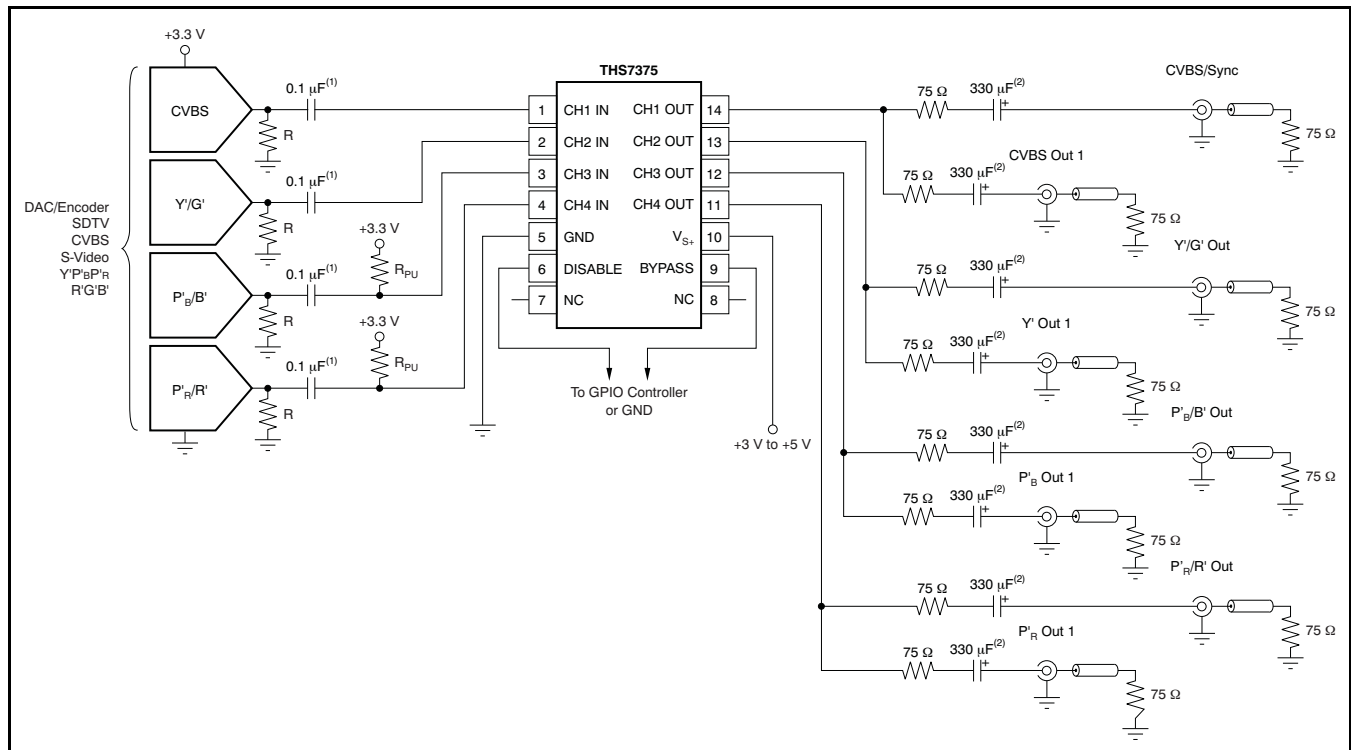

(1) An ac-coupled input is shown in this example. DC coupling is also allowed as long as the DAC output voltage is within the allowable linear input and output voltage range of the THS7375. To dc-couple, remove the 0.1- μF input capacitors and R_{PU} .

(2) An ac-coupled output is shown in this example. DC coupling is also allowed by simply removing these capacitors.

Figure 53. Typical SDTV AC-Input System Driving Two AC-Coupled Video Lines

LOW-PASS FILTER

Each channel of the THS7375 incorporates a sixth-order low-pass filter. These video reconstruction filters minimize the passing of DAC images to the video receiver. Depending on the receiver design, failure to eliminate these DAC images can cause picture quality problems as a result of ADC aliasing. Another benefit of the filter is to smooth out aberrations in the signal that some DACs can have if the internal device filtering is not very good. This technique helps with picture quality and helps ensure that the signal meets video bandwidth requirements.

Each filter has an associated Butterworth characteristic. The benefit of the Butterworth response is that the frequency response is flat, with a relatively steep initial attenuation at the corner frequency. The problem with this characteristic is that the group delay rises near the corner frequency. Group delay is defined as the change in phase (radians/second) divided by a change in frequency. An increase in group delay corresponds to a time domain pulse response that has overshoot and some possible ringing associated with the overshoot.

The use of other type of filters, such as elliptic or chebyshev, are not recommended for video applications because of the very large group delay variations near the corner frequency that results in significant overshoot and ringing. While these elliptic or chebyshev filters may help meet the video standard specifications with respect to amplitude attenuation, the group delay is well beyond the standard specifications. When considering these filter types, keep in mind that video can go from a white pixel to a black pixel over and over again, and ringing can easily occur. Ringing typically causes a display to have ghosting or fuzziness appear on the edges of a sharp transition. On the other hand, a Bessel filter has ideal group delay response, but the rate of attenuation is typically too slow for acceptable image rejection. Thus, the Butterworth filter is a respectable compromise for both attenuation and group delay.

The THS7375 filters have a nominal corner (-3 dB) frequency at 9.5 MHz and a -1 -dB passband typically at 8 MHz. This 9.5-MHz filter is ideal for standard definition (SD) NTSC, PAL, and SECAM composite video (CVBS) signals. It is also useful for s-video signals (Y'C'), 480i/576i Y'P_BP_R, Y'U'V', broadcast G'B'R' (R'G'B') signals, and computer video signals. The 9.5-MHz, -3 -dB corner frequency was designed to achieve 54 dB of attenuation at 27 MHz—a common sampling frequency between the DAC/ADC second and third Nyquist zones found in many video systems. This consideration is important because any signal that appears around this frequency can also appear in the baseband as the result of aliasing effects of an ADC found in a receiver.

Keep in mind that images do not stop at the DAC sampling frequency, f_s (for example, 27 MHz for traditional SD DACs); they continue around the sampling frequencies of $2X f_s$, $3X f_s$, $4X f_s$, etc. (54 MHz, 81 MHz, 108 MHz). Because of these multiple images that an ADC can fold down into the baseband signal, the low-pass filter must also eliminate these higher order images. The THS7375 filters are Butterworth filters and as such, do not *bounce* at higher frequencies and maintain good attenuation performance.

The 9.5-MHz filter frequency was chosen to account for process variations in the THS7375. To ensure that the required video frequencies are effectively passed, the filter corner frequency must be high enough to allow component variations. The other consideration is that the attenuation must be large enough to ensure the anti-aliasing/reconstruction filtering is adequate to meet the system demands. Thus, the filter frequencies were not arbitrarily selected and are a good compromise that should meet the demands of most systems.

Benefits Over Passive Filtering

Two key benefits of using an integrated filter system such as the THS7375 over a passive system are PCB area and filter variations. The small TSSOP-14 package for four video channels is much smaller over a passive RLC network, especially a six-pole passive network. Additionally, consider that inductors have at best $\pm 10\%$ tolerances (normally $\pm 15\%$ to $\pm 20\%$ are common) and capacitors typically have $\pm 10\%$ tolerances. Using a Monte Carlo analysis shows that the filter corner frequency (-3 dB), flatness (-1 dB), Q factor (or peaking), and channel-to-channel delay have wide variations. This approach can lead to potential performance and quality issues in mass-production environments. The THS7375 solves most of these problems with the corner frequency being essentially the only variable.

Another concern about passive filters is the use of inductors. Inductors are magnetic components and are therefore susceptible to electromagnetic coupling/interference (EMC/EMI). Some common coupling can occur because of other nearby video channels that use inductors for filtering, or it can come from nearby switched-mode power supplies. Some other forms of coupling could be from outside sources with strong EMI radiation that can cause failure in EMC testing such as required for CE compliance.

One concern about an active filter in an integrated circuit is the variation of the filter characteristics when the ambient temperature and the subsequent die temperature change. To minimize temperature effects, the THS7375 uses low temperature coefficient resistors and high-quality/low-temperature coefficient capacitors found in the BiCom3X process.

These filters have been specified by design to account for process and temperature variations to maintain proper filter characteristics. This architecture maintains a low channel-to-channel time delay, which is required for proper video signal performance.

Another benefit of the THS7375 over a passive RLC filter is the input and output impedance. The input impedance presented to the DAC may vary significantly with a passive network and may cause voltage variations over frequency. The THS7375 input impedance is 800 k Ω , and only the 2-pF input capacitance plus the PCB trace capacitance impacts the input impedance. As such, the voltage variation appearing at the DAC output is better controlled with a fixed termination resistor and the high input impedance buffer of the THS7375.

On the output side of the filter, a passive filter also has a large impedance variation over frequency. The EIA770 specifications requires the return loss be at least 25 dB over the video frequency range of usage. For a video system, this condition implies the source impedance—which includes the source and the series resistor and the filter—must be better than 75 +j9–8 Ω . The THS7375 is an operational amplifier that approximates an ideal voltage source. A voltage source is desirable because the output impedance is very low and can source and sink current. To properly match the transmission line characteristic impedance of a video line, a 75- Ω series resistor is placed on the output. To minimize reflections and to maintain a good return loss, this output resistance must maintain a 75- Ω impedance. A passive filter impedance variation cannot ensure this consistent performance while the THS7375 has about 1.4- Ω of output impedance at 5-MHz. Thus, the system is much better matched with a THS7375 as compared to a passive filter.

One final advantage of the THS7375 over a passive filter is power dissipation. A DAC driving a video line must be able to drive a 37.5- Ω load—the receiver 75- Ω resistor and the 75- Ω source impedance matching resistor next to the DAC to maintain the source impedance requirement. This approach forces the DAC to drive at least $1.25 V_p$ (100% saturation CVBS)/37.5 Ω = 33.3 mA. A DAC is a current steering element and this amount of current flows internally to the DAC even if the output is 0 V. Thus, power dissipation in the DAC may be very high, especially when four channels are being driven. With a high input impedance and the capability to drive up to two video lines, utilizing the THS7375 can reduce the DAC power dissipation significantly. This reduction occurs because the resistance the DAC is driving can be substantially increased. It is common to set this driving resistance in a DAC by a current-setting resistor on the device. Thus, the resistance can be 300 Ω or more, substantially reducing the current drive demands from the DAC and saving a substantial amount of power. For example, a 3.3-V four-channel DAC dissipates 440 mW for the steering current capability alone (four channels \times 33.3 mA \times 3.3 V) if it must drive a 37.5- Ω load. With a 300- Ω load, the DAC power dissipation as a result of current steering current would only be 55 mW (four channels \times 4.16 mA \times 3.3 V).

Reducing System Gain

The THS7375 has a built-in gain of 5.6 V/V, or 14.95 dB. While this gain matches the needs of many of Texas Instruments' video processors, including the [DaVinci family of products](#), the gain can be easily reduced to meet other needs. The easiest and most effective method of adjusting the gain lower is to simply use a resistor divider on the input to the THS7375, as shown in [Figure 54](#). This solution uses resistors R1 and R2 to accomplish two requirements:

1. Terminate the video DAC with the proper resistance, and
2. Form a resistor divider in before the THS7375 input.

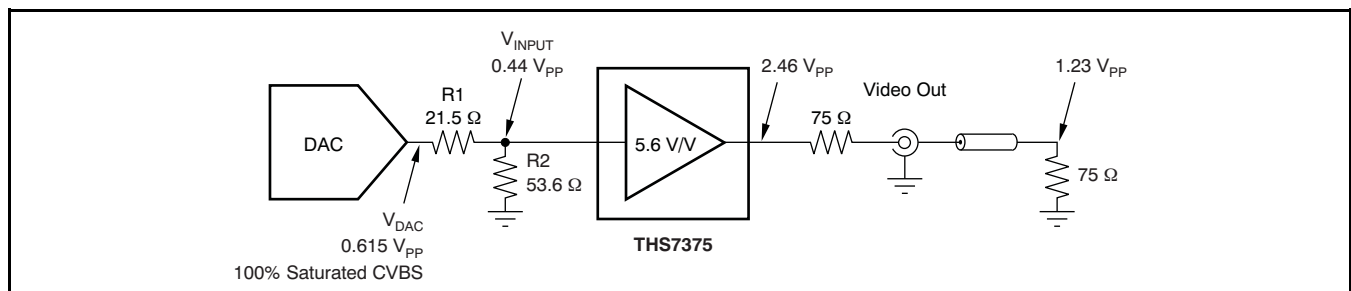

Figure 54. Configuring the THS7375 with 4-V/V (12dB) Gain

The DAC must have a defined termination resistance to properly set the output voltage. R1 and R2 sum together to accomplish this requirement such that $R1 + R2 = \text{DAC termination resistance}$.

The voltage divider, formed by R1 and R2, also creates a voltage divider that reduces the signal voltage appearing at the THS7375 input terminal. The voltage appearing at the THS7375 input is equal to $V_{\text{DAC}} R2 / (R1 + R2)$.

Solving for both of these requirements and simplifying results leads to the general equations:

- $\text{DAC termination} = R_{\text{TERM}} = R1 + R2$
- $V_{\text{INPUT}} = V_{\text{DAC}} R2 / (R1 + R2)$

- $\text{Ratio} = V_{\text{INPUT}} / V_{\text{DAC}}$
- $R2 = R_{\text{TERM}} \times \text{Ratio}$
- $R1 = R_{\text{TERM}} - R2$

As an example, the DAC outputs $0.615 V_{\text{PP}}$ and requires an amplifier gain of $4 V/V$ (12dB) to achieve 100% saturated color CVBS signal requirements. Additionally, the DAC requires a termination resistance of 75Ω . Plugging these requirements into the above equations result in standard resistor values of $R2 = 53.6 \Omega$ and $R1 = 21.5 \Omega$.

EVALUATION MODULE

To evaluate the THS7375, a product evaluation module (EVM) is available. The EVM allows for testing the THS7375 in many different configuration. Inputs and outputs include BNC connectors commonly found in video systems along with $75\text{-}\Omega$ input termination resistors, $75\text{-}\Omega$ series source termination resistors, and $75\text{-}\Omega$ characteristic impedance traces. Several unpopulated component pads are found on the EVM to allow for different input and output configurations as dictated by the user. This EVM is designed to be used with a single-supply from $2.85 V$ up to $5 V$.

The EVM default input configuration sets all channels for dc input coupling. The input signal must be within $0 V$ to about $0.52 V$ for proper operation with $3.3 V$ supply and up to $0.8 V$ for $5V$ supply. Failure to be within this range saturates and/or clips the output signal. If the input range is beyond this range, or if the signal voltage is unknown, or coming from a current sink DAC, then ac input configuration is desirable. This option is easily accomplished with the EVM by simply replacing Z1, Z2, Z3, and Z4 $0\text{-}\Omega$ resistors with $0.1\text{-}\mu\text{F}$ capacitors.

For ac-coupled input and sync-tip clamp (STC) functionality commonly used for CVBS, s-video Y', component Y' signals, and R'G'B' signals with embedded sync, then no other changes are needed. However, if a bias voltage is needed after the input capacitor which is commonly needed for s-video C', component P_B and P_R , and non-sync embedded R'G'B' signals, then a pull-up resistor should be added to the signal on the EVM. This adjustment is

easily done by simply adding a resistor to any of the following resistor pads; RX1, RX3, RX5, or RX7. A common value to use is $10.8 M\Omega$. Note that even signals with embedded sync can also use bias mode if desired.

The EVM default output configuration sets all channels for ac output coupling. The $470\text{-}\mu\text{F}$ and $0.1\text{-}\mu\text{F}$ capacitors work well for most ac-coupled systems. However, if dc-coupled output is desired, then replacing the $0.1\text{-}\mu\text{F}$ capacitors—C12, C14, C16, and C17—with $0\text{-}\Omega$ resistors works well. Removing the $470\text{-}\mu\text{F}$ capacitors is optional, but removing them from the EVM eliminates a few picofarads of stray capacitance on each signal path which may be desirable.

The THS7375EVM incorporates an easy method to configure the bypass mode and the disable mode. The use of JP1 controls the disable feature while JP4 controls the bypass feature. While there is a space on the EVM board for JP2 and JP3, these are not utilized for the THS7375. Connection of JP1 to GND applies $0 V$ to the disable pin and the THS7375 operates normally. Moving JP1 to $+V_S$ causes the THS7375 to be in disable mode. Connection of JP4 to GND places the THS7375 in filter mode while moving JP4 to $+V_S$ places the THS7375 in bypass mode.

Figure 55 shows the THS7375EVM schematic. Figure 56 and Figure 57 illustrate the two layers of the EVM PCB, incorporating standard high-speed layout practices. Table 2 lists the bill of materials as supplied from Texas Instruments.

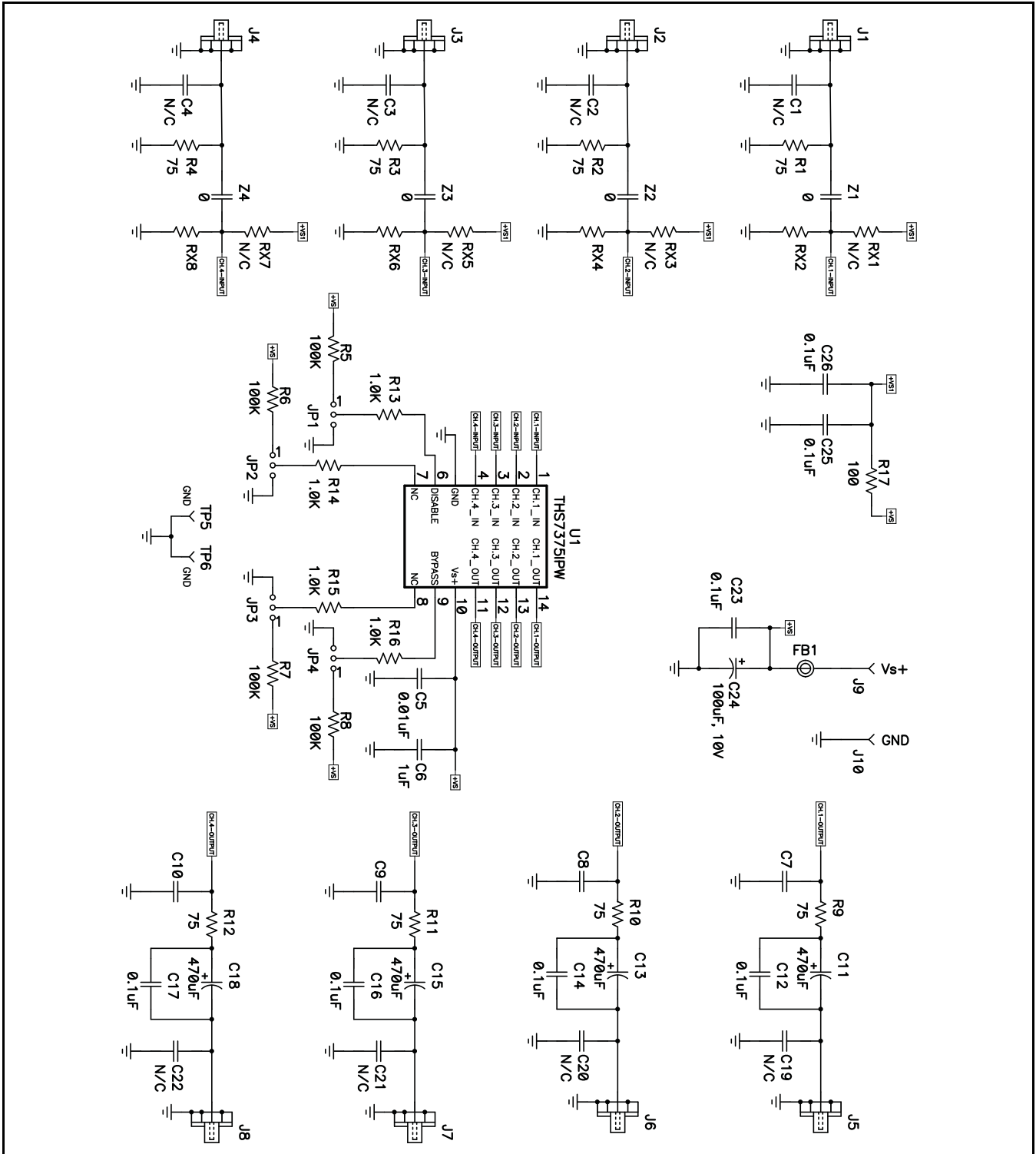

Figure 55. THS7375 EVM Schematic

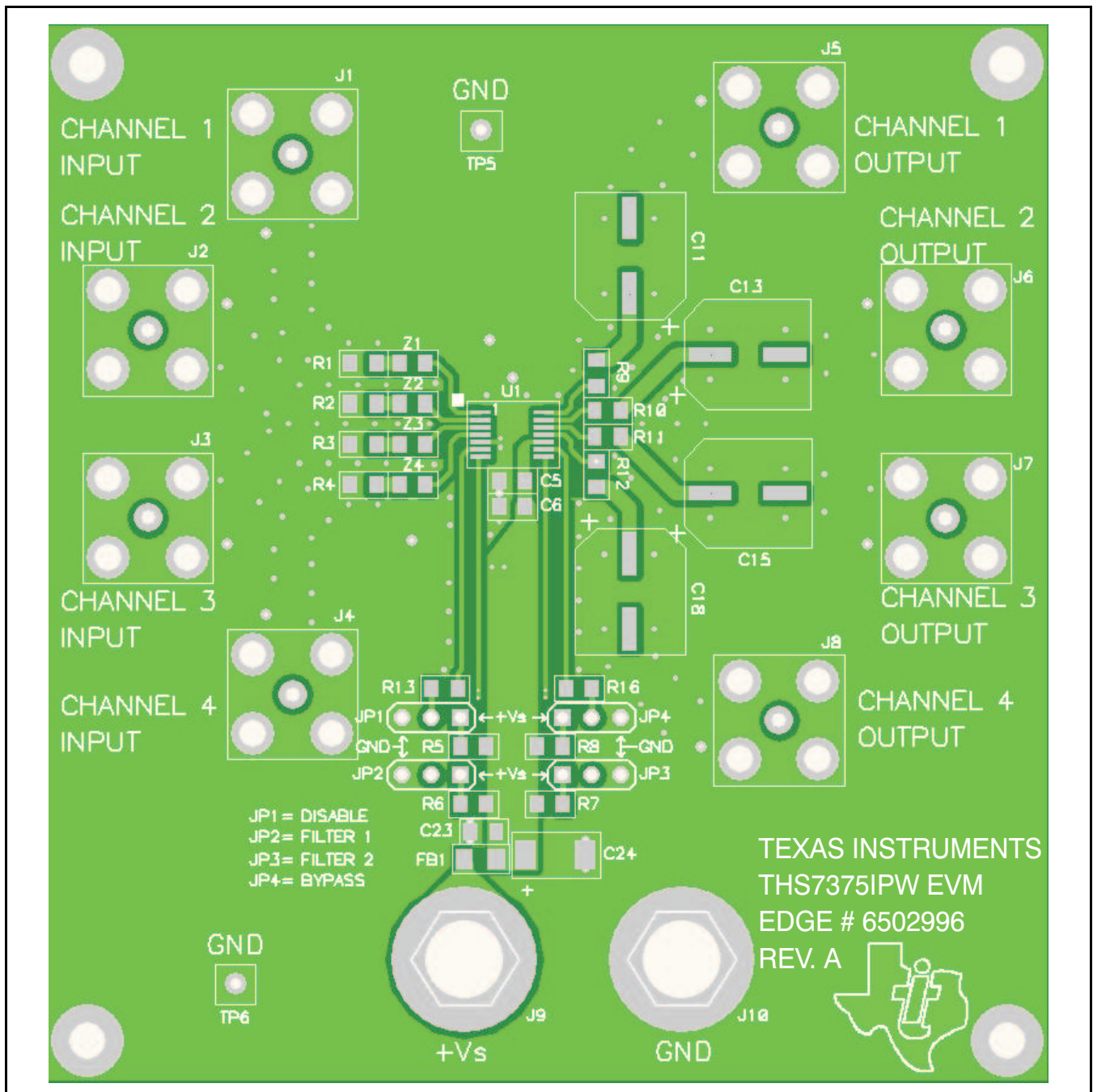

Figure 56. THS7375 EVM PCB Top Layer

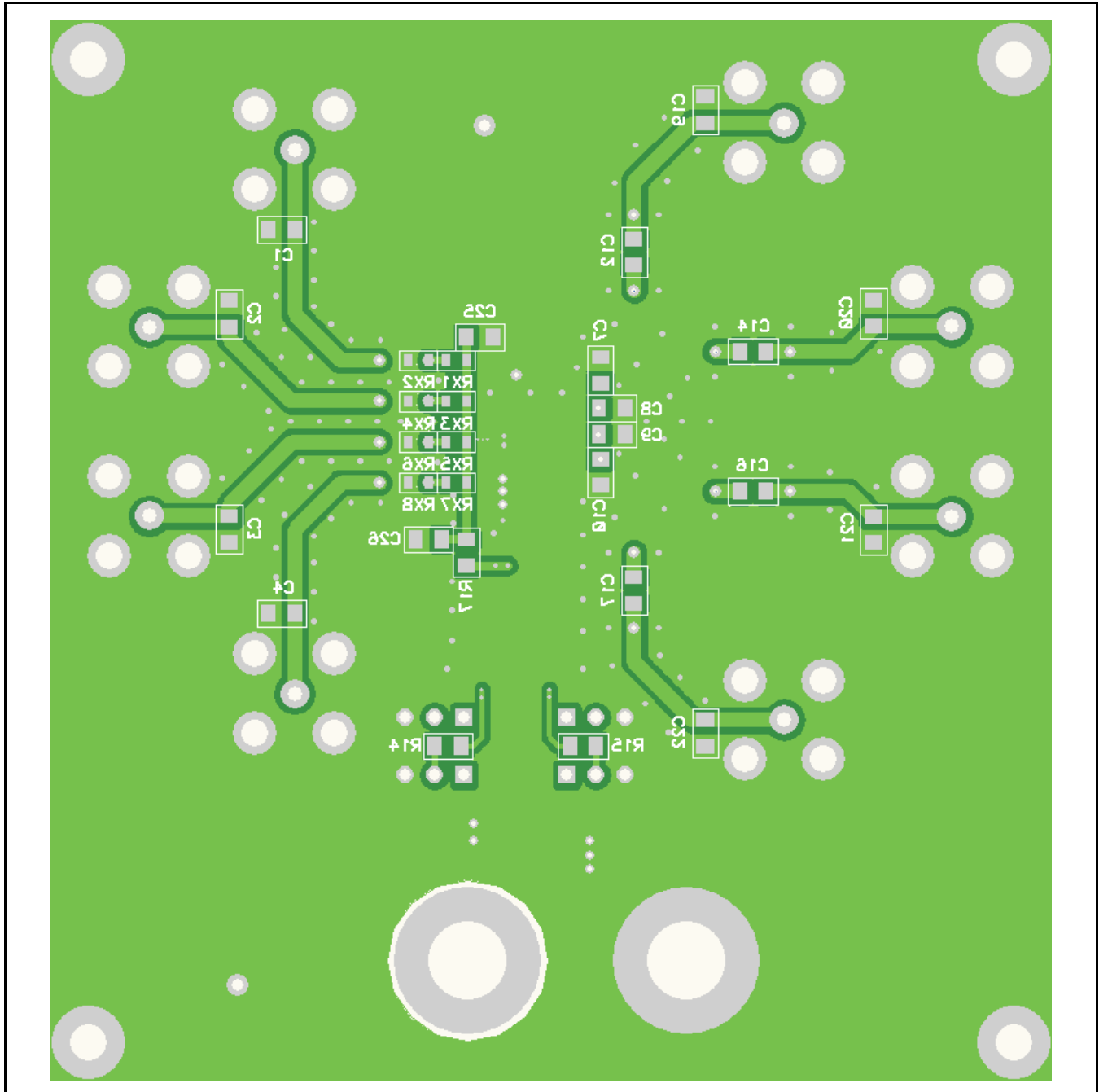

Figure 57. THS7375 EVM PCB Bottom Layer

THS7375EVM Bill of Materials

Table 2. THS7375 EVM

ITEM	REF DES	QTY	DESCRIPTION	SMD SIZE	MANUFACTURER PART NUMBER	DISTRIBUTOR PART NUMBER
1	FB1	1	Bead, Ferrite, 2.5 A, 330 Ω	0805	(TDK) MPZ2012S331A	(Digi-Key) 445-1569-1-ND
2	C24	1	Capacitor, 100 μF, Tantalum, 10 V, 10%, Low-ESR	C	(AVX) TPSC107K010R0100	(Digi-Key) 478-1765-1-ND
3	C1–C4, C7–C10, C19, C20–C22	12	Open	0805		
4	C5	1	Capacitor, 0.01 μF, Ceramic, 100 V, X7R	0805	(AVX) 08051C103KAT2A	(Digi-Key) 478-1358-1-ND
5	C12, C14, C16, C17, C23, C25, C26	7	Capacitor, 0.1 μF, Ceramic, 50 V, X7R	0805	(AVX) 08055C104KAT2A	(Digi-Key) 478-1395-1-ND
6	C6	1	Capacitor, 1 μF, Ceramic, 16 V, X7R	0805	(TDK) C2012X7R1C105K	(Digi-Key) 445-1358-1-ND
7	C11, C13, C15, C18	4	Capacitor, Aluminum, 470 μF, 10 V, 20%	F	(Cornell) AFK477M10F24B-F	(Newark) 66K0965
8	RX1–RX8	8	Open	0603		
9	R6, R7, R14, R15	4	Open	0805		
10	Z1–Z4	4	Resistor, 0 Ω	0805	(ROHM) MCR10EZHZJ000	(Digi-Key) RHM0.0ACT-ND
11	R1–R4, R9–R12	8	Resistor, 75 Ω, 1/8 W, 1%	0805	(ROHM) MCR10EZHF75.0	(Digi-Key) RHM75.0CCT-ND
12	R17	1	Resistor, 100 Ω, 1/8 W, 1%	0805	(ROHM) MCR10EZHF1000	(Digi-Key) RHM100CCT-ND
13	R13, R16	2	Resistor, 1 kΩ, 1/8 W, 1%	0805	(ROHM) MCR10EZHF1001	(Digi-Key) RHM1.00KCCT-ND
14	R5, R8	2	Resistor, 100 kΩ, 1/8 W, 1%	0805	(ROHM) MCR10EZHF1003	(Digi-Key) RHM100KCCT-ND
15	J9, J10	2	Jack, Banana Receptance, 0.25" dia. hole		(SPC) 813	(Newark) 39N867
16	J1–J8	8	Connector, BNC, Jack, 75 Ω		(Amphenol) 31-5329-72RFX	(Newark) 93F7554
17	TP5, TP6	2	Test Point, Black		(Keystone) 5001	(Digi-Key) 5001K-ND
18	JP2, JP3	2	Open	3 possible		
19	JP1, JP4	2	Header, 0.1" CTRS, 0.025" sq. pins	3 possible	(Sullins) PBC36SAAN	(Digi-Key) S1011E-36-ND
20	JP1, JP4	2	Shunts		(Sullins) SSC02SYAN	(Digi-Key) S9002-ND
21	U1	1	IC, THS7375	PW	(TI) THS7375IPW	
22		4	Standoff, 4-40 HEX, 0.625" length		(Keystone) 1808	(Digi-Key) 1808K-ND
23		4	Screw, Phillips, 4-40, 0.250"		(BF) PMS 440 0031 PH	(Digi-Key) H343-ND
24		1	Printed Circuit Board		(TI) Edge# 6502996 Rev. A	

REVISION HISTORY

NOTE: Page numbers for previous revisions may differ from page numbers in the current version.

Changes from Original (September 2008) to Revision A	Page
• Added Figure 26	13
• Added Figure 45	17

EVALUATION BOARD/KIT IMPORTANT NOTICE

Texas Instruments (TI) provides the enclosed product(s) under the following conditions:

This evaluation board/kit is intended for use for **ENGINEERING DEVELOPMENT, DEMONSTRATION, OR EVALUATION PURPOSES ONLY** and is not considered by TI to be a finished end-product fit for general consumer use. Persons handling the product(s) must have electronics training and observe good engineering practice standards. As such, the goods being provided are not intended to be complete in terms of required design-, marketing-, and/or manufacturing-related protective considerations, including product safety and environmental measures typically found in end products that incorporate such semiconductor components or circuit boards. This evaluation board/kit does not fall within the scope of the European Union directives regarding electromagnetic compatibility, restricted substances (RoHS), recycling (WEEE), FCC, CE or UL, and therefore may not meet the technical requirements of these directives or other related directives.

Should this evaluation board/kit not meet the specifications indicated in the User's Guide, the board/kit may be returned within 30 days from the date of delivery for a full refund. **THE FOREGOING WARRANTY IS THE EXCLUSIVE WARRANTY MADE BY SELLER TO BUYER AND IS IN LIEU OF ALL OTHER WARRANTIES, EXPRESSED, IMPLIED, OR STATUTORY, INCLUDING ANY WARRANTY OF MERCHANTABILITY OR FITNESS FOR ANY PARTICULAR PURPOSE.**

The user assumes all responsibility and liability for proper and safe handling of the goods. Further, the user indemnifies TI from all claims arising from the handling or use of the goods. Due to the open construction of the product, it is the user's responsibility to take any and all appropriate precautions with regard to electrostatic discharge.

EXCEPT TO THE EXTENT OF THE INDEMNITY SET FORTH ABOVE, NEITHER PARTY SHALL BE LIABLE TO THE OTHER FOR ANY INDIRECT, SPECIAL, INCIDENTAL, OR CONSEQUENTIAL DAMAGES.

TI currently deals with a variety of customers for products, and therefore our arrangement with the user **is not exclusive**.

TI assumes **no liability for applications assistance, customer product design, software performance, or infringement of patents or services described herein**.

Please read the User's Guide and, specifically, the Warnings and Restrictions notice in the User's Guide prior to handling the product. This notice contains important safety information about temperatures and voltages. For additional information on TI's environmental and/or safety programs, please contact the TI application engineer or visit www.ti.com/esh.

No license is granted under any patent right or other intellectual property right of TI covering or relating to any machine, process, or combination in which such TI products or services might be or are used.

FCC Warning

This evaluation board/kit is intended for use for **ENGINEERING DEVELOPMENT, DEMONSTRATION, OR EVALUATION PURPOSES ONLY** and is not considered by TI to be a finished end-product fit for general consumer use. It generates, uses, and can radiate radio frequency energy and has not been tested for compliance with the limits of computing devices pursuant to part 15 of FCC rules, which are designed to provide reasonable protection against radio frequency interference. Operation of this equipment in other environments may cause interference with radio communications, in which case the user at his own expense will be required to take whatever measures may be required to correct this interference.

EVM WARNINGS AND RESTRICTIONS

It is important to operate this EVM within the input voltage range of 2.85 V to 5.5 V single supply and the output voltage range of 0 V to 5.5 V.

Exceeding the specified input range may cause unexpected operation and/or irreversible damage to the EVM. If there are questions concerning the input range, please contact a TI field representative prior to connecting the input power.

Applying loads outside of the specified output range may result in unintended operation and/or possible permanent damage to the EVM. Please consult the EVM User's Guide prior to connecting any load to the EVM output. If there is uncertainty as to the load specification, please contact a TI field representative.

During normal operation, some circuit components may have case temperatures greater than +85°C. The EVM is designed to operate properly with certain components above +85°C as long as the input and output ranges are maintained. These components include but are not limited to linear regulators, switching transistors, pass transistors, and current sense resistors. These types of devices can be identified using the EVM schematic located in the EVM User's Guide. When placing measurement probes near these devices during operation, please be aware that these devices may be very warm to the touch.

Mailing Address: Texas Instruments, Post Office Box 655303, Dallas, Texas 75265

Copyright © 2009, Texas Instruments Incorporated

PACKAGING INFORMATION

Orderable Device	Status (1)	Package Type	Package Drawing	Pins	Package Qty	Eco Plan (2)	Lead/Ball Finish (6)	MSL Peak Temp (3)	Op Temp (°C)	Device Marking (4/5)	Samples
THS7375IPW	ACTIVE	TSSOP	PW	14	90	Green (RoHS & no Sb/Br)	CU NIPDAU	Level-2-260C-1 YEAR	-40 to 85	THS7375	Samples
THS7375IPWR	ACTIVE	TSSOP	PW	14	2000	Green (RoHS & no Sb/Br)	CU NIPDAU	Level-2-260C-1 YEAR	-40 to 85	THS7375	Samples

(1) The marketing status values are defined as follows:

ACTIVE: Product device recommended for new designs.

LIFEBUY: TI has announced that the device will be discontinued, and a lifetime-buy period is in effect.

NRND: Not recommended for new designs. Device is in production to support existing customers, but TI does not recommend using this part in a new design.

PREVIEW: Device has been announced but is not in production. Samples may or may not be available.

OBSOLETE: TI has discontinued the production of the device.

(2) Eco Plan - The planned eco-friendly classification: Pb-Free (RoHS), Pb-Free (RoHS Exempt), or Green (RoHS & no Sb/Br) - please check <http://www.ti.com/productcontent> for the latest availability information and additional product content details.

TBD: The Pb-Free/Green conversion plan has not been defined.

Pb-Free (RoHS): TI's terms "Lead-Free" or "Pb-Free" mean semiconductor products that are compatible with the current RoHS requirements for all 6 substances, including the requirement that lead not exceed 0.1% by weight in homogeneous materials. Where designed to be soldered at high temperatures, TI Pb-Free products are suitable for use in specified lead-free processes.

Pb-Free (RoHS Exempt): This component has a RoHS exemption for either 1) lead-based flip-chip solder bumps used between the die and package, or 2) lead-based die adhesive used between the die and leadframe. The component is otherwise considered Pb-Free (RoHS compatible) as defined above.

Green (RoHS & no Sb/Br): TI defines "Green" to mean Pb-Free (RoHS compatible), and free of Bromine (Br) and Antimony (Sb) based flame retardants (Br or Sb do not exceed 0.1% by weight in homogeneous material)

(3) MSL, Peak Temp. - The Moisture Sensitivity Level rating according to the JEDEC industry standard classifications, and peak solder temperature.

(4) There may be additional marking, which relates to the logo, the lot trace code information, or the environmental category on the device.

(5) Multiple Device Markings will be inside parentheses. Only one Device Marking contained in parentheses and separated by a "~" will appear on a device. If a line is indented then it is a continuation of the previous line and the two combined represent the entire Device Marking for that device.

(6) Lead/Ball Finish - Orderable Devices may have multiple material finish options. Finish options are separated by a vertical ruled line. Lead/Ball Finish values may wrap to two lines if the finish value exceeds the maximum column width.

Important Information and Disclaimer: The information provided on this page represents TI's knowledge and belief as of the date that it is provided. TI bases its knowledge and belief on information provided by third parties, and makes no representation or warranty as to the accuracy of such information. Efforts are underway to better integrate information from third parties. TI has taken and continues to take reasonable steps to provide representative and accurate information but may not have conducted destructive testing or chemical analysis on incoming materials and chemicals. TI and TI suppliers consider certain information to be proprietary, and thus CAS numbers and other limited information may not be available for release.

In no event shall TI's liability arising out of such information exceed the total purchase price of the TI part(s) at issue in this document sold by TI to Customer on an annual basis.

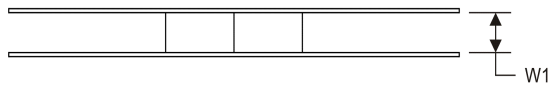
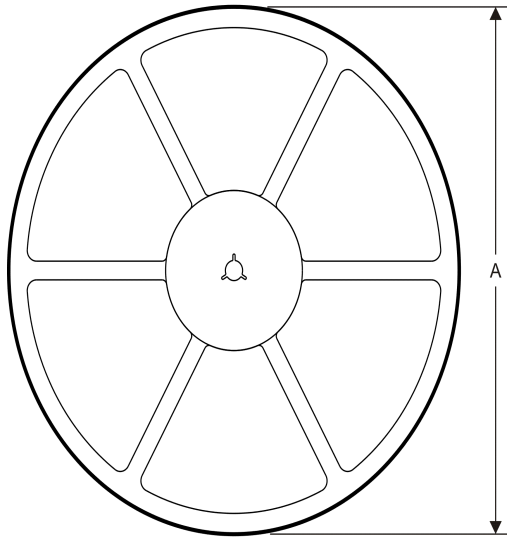
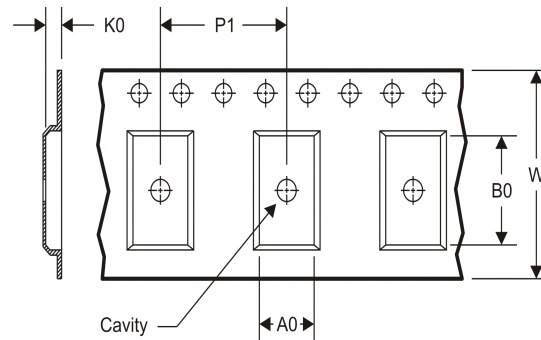
TAPE AND REEL INFORMATION
REEL DIMENSIONS

TAPE DIMENSIONS

A0	Dimension designed to accommodate the component width
B0	Dimension designed to accommodate the component length
K0	Dimension designed to accommodate the component thickness
W	Overall width of the carrier tape
P1	Pitch between successive cavity centers

TAPE AND REEL INFORMATION

*All dimensions are nominal

Device	Package Type	Package Drawing	Pins	SPQ	Reel Diameter (mm)	Reel Width W1 (mm)	A0 (mm)	B0 (mm)	K0 (mm)	P1 (mm)	W (mm)	Pin1 Quadrant
THS7375IPWR	TSSOP	PW	14	2000	330.0	12.4	6.9	5.6	1.6	8.0	12.0	Q1

TAPE AND REEL BOX DIMENSIONS

*All dimensions are nominal

Device	Package Type	Package Drawing	Pins	SPQ	Length (mm)	Width (mm)	Height (mm)
THS7375IPWR	TSSOP	PW	14	2000	367.0	367.0	35.0

PW (R-PDSO-G14)

PLASTIC SMALL OUTLINE



4211284-2/G 08/15

- NOTES:
- All linear dimensions are in millimeters.
 - This drawing is subject to change without notice.
 - Publication IPC-7351 is recommended for alternate designs.
 - Laser cutting apertures with trapezoidal walls and also rounding corners will offer better paste release. Customers should contact their board assembly site for stencil design recommendations. Refer to IPC-7525 for other stencil recommendations.
 - Customers should contact their board fabrication site for solder mask tolerances between and around signal pads.

IMPORTANT NOTICE

Texas Instruments Incorporated and its subsidiaries (TI) reserve the right to make corrections, enhancements, improvements and other changes to its semiconductor products and services per JESD46, latest issue, and to discontinue any product or service per JESD48, latest issue. Buyers should obtain the latest relevant information before placing orders and should verify that such information is current and complete. All semiconductor products (also referred to herein as "components") are sold subject to TI's terms and conditions of sale supplied at the time of order acknowledgment.

TI warrants performance of its components to the specifications applicable at the time of sale, in accordance with the warranty in TI's terms and conditions of sale of semiconductor products. Testing and other quality control techniques are used to the extent TI deems necessary to support this warranty. Except where mandated by applicable law, testing of all parameters of each component is not necessarily performed.

TI assumes no liability for applications assistance or the design of Buyers' products. Buyers are responsible for their products and applications using TI components. To minimize the risks associated with Buyers' products and applications, Buyers should provide adequate design and operating safeguards.

TI does not warrant or represent that any license, either express or implied, is granted under any patent right, copyright, mask work right, or other intellectual property right relating to any combination, machine, or process in which TI components or services are used. Information published by TI regarding third-party products or services does not constitute a license to use such products or services or a warranty or endorsement thereof. Use of such information may require a license from a third party under the patents or other intellectual property of the third party, or a license from TI under the patents or other intellectual property of TI.

Reproduction of significant portions of TI information in TI data books or data sheets is permissible only if reproduction is without alteration and is accompanied by all associated warranties, conditions, limitations, and notices. TI is not responsible or liable for such altered documentation. Information of third parties may be subject to additional restrictions.

Resale of TI components or services with statements different from or beyond the parameters stated by TI for that component or service voids all express and any implied warranties for the associated TI component or service and is an unfair and deceptive business practice. TI is not responsible or liable for any such statements.

Buyer acknowledges and agrees that it is solely responsible for compliance with all legal, regulatory and safety-related requirements concerning its products, and any use of TI components in its applications, notwithstanding any applications-related information or support that may be provided by TI. Buyer represents and agrees that it has all the necessary expertise to create and implement safeguards which anticipate dangerous consequences of failures, monitor failures and their consequences, lessen the likelihood of failures that might cause harm and take appropriate remedial actions. Buyer will fully indemnify TI and its representatives against any damages arising out of the use of any TI components in safety-critical applications.

In some cases, TI components may be promoted specifically to facilitate safety-related applications. With such components, TI's goal is to help enable customers to design and create their own end-product solutions that meet applicable functional safety standards and requirements. Nonetheless, such components are subject to these terms.

No TI components are authorized for use in FDA Class III (or similar life-critical medical equipment) unless authorized officers of the parties have executed a special agreement specifically governing such use.

Only those TI components which TI has specifically designated as military grade or "enhanced plastic" are designed and intended for use in military/aerospace applications or environments. Buyer acknowledges and agrees that any military or aerospace use of TI components which have **not** been so designated is solely at the Buyer's risk, and that Buyer is solely responsible for compliance with all legal and regulatory requirements in connection with such use.

TI has specifically designated certain components as meeting ISO/TS16949 requirements, mainly for automotive use. In any case of use of non-designated products, TI will not be responsible for any failure to meet ISO/TS16949.

Products

Audio	www.ti.com/audio
Amplifiers	amplifier.ti.com
Data Converters	dataconverter.ti.com
DLP® Products	www.dlp.com
DSP	dsp.ti.com
Clocks and Timers	www.ti.com/clocks
Interface	interface.ti.com
Logic	logic.ti.com
Power Mgmt	power.ti.com
Microcontrollers	microcontroller.ti.com
RFID	www.ti-rfid.com
OMAP Applications Processors	www.ti.com/omap
Wireless Connectivity	www.ti.com/wirelessconnectivity

Applications

Automotive and Transportation	www.ti.com/automotive
Communications and Telecom	www.ti.com/communications
Computers and Peripherals	www.ti.com/computers
Consumer Electronics	www.ti.com/consumer-apps
Energy and Lighting	www.ti.com/energy
Industrial	www.ti.com/industrial
Medical	www.ti.com/medical
Security	www.ti.com/security
Space, Avionics and Defense	www.ti.com/space-avionics-defense
Video and Imaging	www.ti.com/video

TI E2E Community

e2e.ti.com

Looking for pricing, stock, or lifecycle information?

Click below to explore more details on WIN SOURCE:

 [View THS7375IPWR on WIN SOURCE](#)

 [Texas Instruments](#) Information

Optimize Your Supply Chain with WIN SOURCE Solutions

-  Global Sourcing Solution
-  Obsolete Management
-  Cost Control Management
-  Shortage Management
-  Alternative Solution
-  Excess Inventory Management