

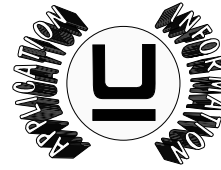

THE DATASHEET OF UC2834DW





High Efficiency Linear Regulator

FEATURES

- Minimum $V_{IN} - V_{OUT}$ Less Than 0.5V At 5A Load With External Pass Device
- Equally Usable For Either Positive or Negative Regulator Design
- Adjustable Low Threshold Current Sense Amplifier
- Under And Over-Voltage Fault Alert With Programmable Delay
- Over-Voltage Fault Latch With 100mA Crowbar Drive Output

DESCRIPTION

The UC1834 family of integrated circuits is optimized for the design of low input-output differential linear regulators. A high gain amplifier and 200mA sink or source drive outputs facilitate high output current designs which use an external pass device. With both positive and negative precision references, either polarity of regulator can be implemented. A current sense amplifier with a low, adjustable, threshold can be used to sense and limit currents in either the positive or negative supply lines.

In addition, this series of parts has a fault monitoring circuit which senses both under and over-voltage fault conditions. After a user defined delay for transient rejection, this circuitry provides a fault alert output for either fault condition. In the over-voltage case, a 100mA crowbar output is activated. An over-voltage latch will maintain the crowbar output and can be used to shutdown the driver outputs. System control to the device can be accommodated at a single input which will act as both a supply reset and remote shutdown terminal. These die are protected against excessive power dissipation by an internal thermal shutdown function.

BLOCK DIAGRAM

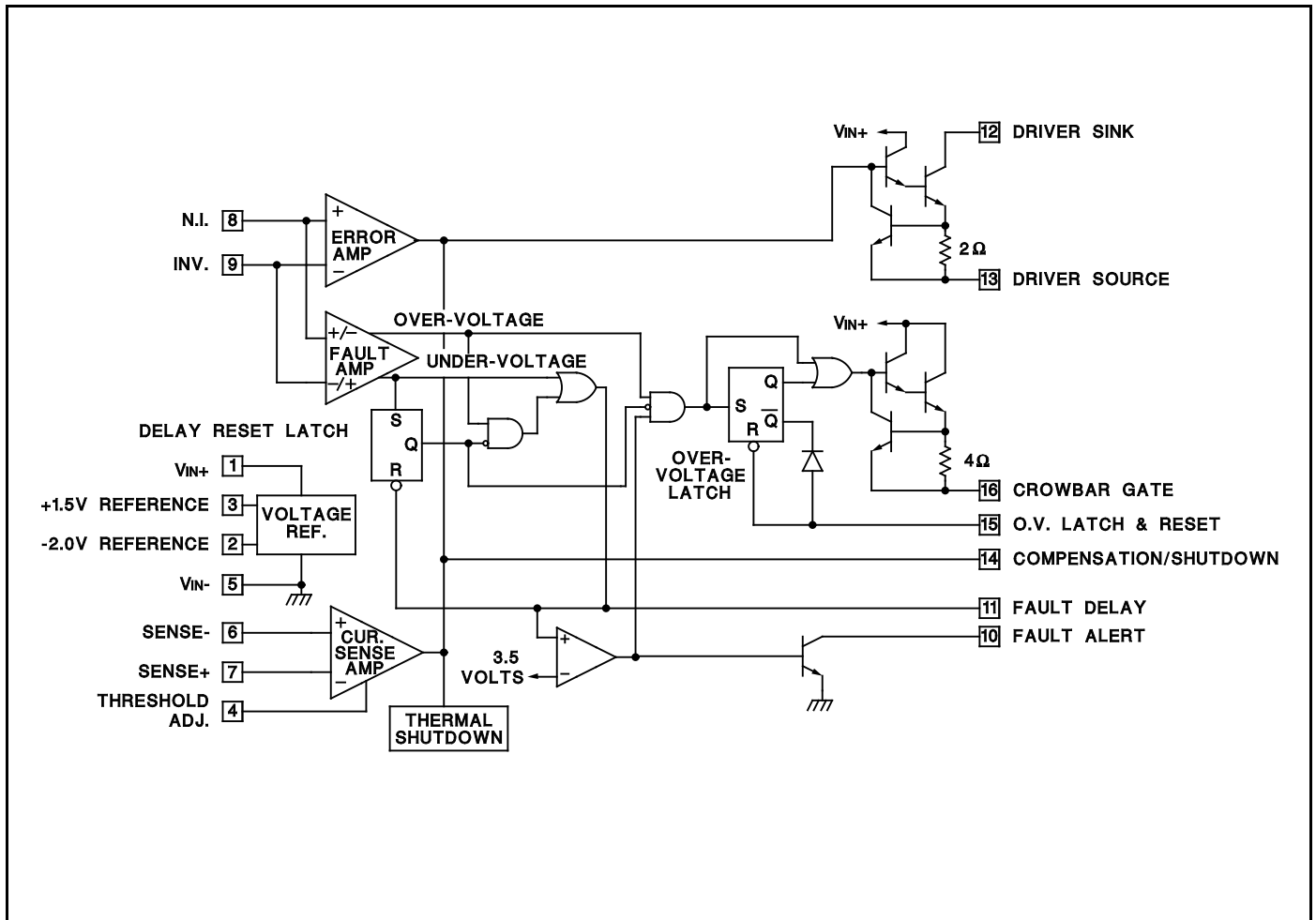

ABSOLUTE MAXIMUM RATINGS (Note 1)

Input Supply Voltage, V_{IN+}	40V
Driver Current	400mA
Driver Source to Sink Voltage	40V
Crowbar Current	-200mA
+1.5V Reference Output Current	-10mA
Fault Alert Voltage	40V
Fault Alert Current	15mA
Error Amplifier Inputs	-0.5V to 35V
Current Sense Inputs	-0.5V to 40V
O.V. Latch Output Voltage	-0.5V to 40V
O.V. Latch Output Current	15mA

Power Dissipation at $T_A = 25^\circ\text{C}$	1000mW
Power Dissipation at $T_c = 25^\circ\text{C}$	2000mW
Operating Junction Temperature	-55°C to +150°C
Storage Temperature	-65°C to +150°C
Lead Temperature (soldering, 10 seconds)	300°C

*Note 1: Voltages are reference to V_{IN-} , Pin 5.
 Currents are positive into, negative out of the specified terminals.
 Consult Packaging section of Databook for thermal limitations and considerations of package.*

CONNECTION DIAGRAMS

**DIL-16, SOIC-16 (TOP VIEW)
 J or N Package, DW Package**

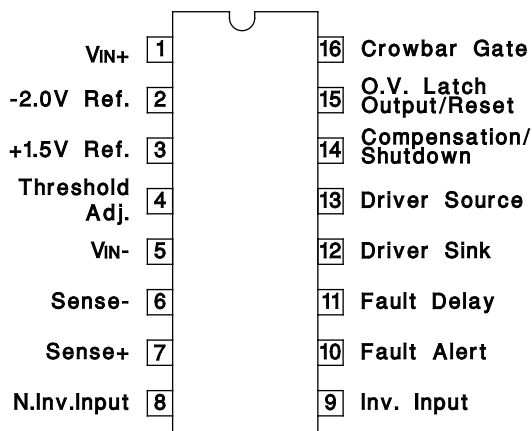

**PLCC-20, LCC-20 (TOP VIEW)
 Q, L Packages**

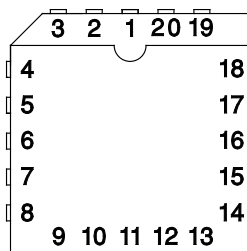

PACKAGE PIN FUNCTION	
FUNCTION	PIN
N/C	1
V_{IN+}	2
-2.0V REF	3
+1.5V REF	4
Threshold Adjust	5
N/C	6
V_{IN-}	7
Sense-	8
Sense+	9
N.Inv. Input	10
N/C	11
Inv. Input	12
Fault Alert	13
Fault Delay	14
Driver Sink	15
N/C	16
Driver Source	17
Compensation/ Shutdown	18
O.V. Latch Output/Reset	19
Crowbar Gate	20

ELECTRICAL CHARACTERISTICS: Unless otherwise stated, these specifications apply for $T_A = -55^{\circ}\text{C}$ to $+125^{\circ}\text{C}$ for the UC1834, -40°C to $+85^{\circ}\text{C}$ for the UC2834, and 0°C to $+70^{\circ}\text{C}$ for the UC3834. $V_{IN+} = 15\text{V}$, $V_{IN-} = 0\text{V}$, $T_A = T_J$.

PARAMETER	TEST CONDITIONS	UC1834 UC2834			UC3834			UNITS
		MIN	TYP	MAX	MIN	TYP	MAX	
Turn-on Characteristics								
Standby Supply Current			5.5	7		5.5	10	mA
+1.5 Volt Reference								
Output Voltage	$T_J = 25^{\circ}\text{C}$	1.485	1.5	1.515	1.47	1.5	1.53	V
	$T_{J(\text{MIN})} \leq T_J \leq T_{J(\text{MAX})}$	1.47		1.53	1.455		1.545	
Line Regulation	$V_{IN+} = 5$ to 35V		1	10		1	15	mV
Load Regulation	$I_{OUT} = 0$ to 2mA		1	10		1	15	mV
-2.0 Volt Reference (Note 2)								
Output Voltage (Referenced to V_{IN+})	$T_J = 25^{\circ}\text{C}$	-2.04	-2	-1.96	-2.06	-2	-1.94	V
	$T_{J(\text{MIN})} \leq T_J \leq T_{J(\text{MAX})}$	-2.06		-1.94	-2.08		-1.92	
Line Regulation	$V_{IN+} = 5$ to 35V		1.5	15		1.5	20	mV
Output Impedance			2.3			2.3		k Ω
Error Amplifier Section								
Input Offset Voltage	$V_{CM} = 1.5\text{V}$		1	6		1	10	mV
Input Bias Current	$V_{CM} = 1.5\text{V}$		-1	-4		-1	-8	μA
Input Offset Current	$V_{CM} = 1.5\text{V}$		0.1	1		0.1	2	μA
Small Signal Open Loop Gain	Output @ Pin 14, Pin 12 = V_{IN+} Pin 13, 20Ω to V_{IN-}	50	65		50	65		dB
CMRR	$V_{CM} = 0.5$ to 33V , $V_{IN+} = 35\text{V}$	60	80		60	80		dB
PSRR	$V_{IN+} = 5$ to 35V , $V_{CM} = 1.5\text{V}$	70	100		70	100		dB
Driver Section								
Maximum Output Current		200	350		200	350		mA
Saturation Voltage	$I_{OUT} = 100\text{mA}$		0.5	1.2		0.5	1.5	V
Output Leakage Current	Pin 12 = 35V , Pin 13 = V_{IN-} , Pin 14 = V_{IN-}		0.1	50		0.1	50	μA
Shutdown Input Voltage at Pin 14	$I_{OUT} \leq 100\mu\text{A}$, Pin 13 = V_{IN-} , Pin 12 = V_{IN+}	0.4	1		0.4	1		V
Shutdown Input Current at Pin 14	Pin 14 = V_{IN-} , Pin 12 = V_{IN+} $I_{OUT} \leq 100\mu\text{A}$, Pin 13 = V_{IN-}		-100	-150		-100	-150	μA
Thermal Shutdown (Note 3)			165			165		$^{\circ}\text{C}$
Fault Amplifier Section								
Under- and Over-Voltage Fault Threshold	$V_{CM} = 1.5\text{V}$, @ E/A Inputs	120	150	180	110	150	190	mV
Common Mode Sensitivity	$V_{IN+} = 35\text{V}$, $V_{CM} = 1.5$ to 33V		-0.4	-0.8		-0.4	-1.0	mV/V
Supply Sensitivity	$V_{CM} = 1.5\text{V}$, $V_{IN+} = 5$ to 35V		-0.5	-1.0		-0.5	-1.2	mV/V
Fault Delay		30	45	60	30	45	60	ms/ μF
Fault Alert Output Current		2	5		2	5		mA
Fault Alert Saturation Voltage	$I_{OUT} = 1\text{mA}$		0.2	0.5		0.2	0.5	V
O.V. Latch Output Current		2	4		2	4		mA
O.V. Latch Saturation Voltage	$I_{OUT} = 1\text{mA}$		1.0	1.3		1.0	1.3	V
O.V. Latch Output Reset Voltage		0.3	0.4	0.6	0.3	0.4	0.6	V
Crowbar Gate Current		-100	-175		-100	-175		mA
Crowbar Gate Leakage Current	$V_{IN+} = 35\text{V}$, Pin 16 = V_{IN-}		-0.5	-50		-0.5	-50	μA

Note 2: When using both the 1.5V and -2.0V references the current out of pin 3 should be balanced by an equivalent current into Pin 2. The -2.0V output will change -2.3mV per μA of imbalance.

Note 3: Thermal shutdown turns off the driver. If Pin 15 (O.V. Latch Output) is tied to Pin 14 (Compensation/Shutdown) the O.V. Latch will be reset.

ELECTRICAL CHARACTERISTICS: Unless otherwise stated, these specifications apply for $T_A = -55^{\circ}\text{C}$ to $+125^{\circ}\text{C}$ for the UC1834, -40°C to $+85^{\circ}\text{C}$ for the UC2834, and 0°C to $+70^{\circ}\text{C}$ for the UC3834. $V_{IN+} = 15\text{V}$, $V_{IN-} = 0\text{V}$. $T_A = T_J$

PARAMETER	TEST CONDITIONS	UC1834 UC2834			UC3834			UNITS
		MIN	TYP	MAX	MIN	TYP	MAX	
Current Sense Amplifier Section								
Threshold Voltage	Pin 4 Open, $V_{CM} = V_{IN+}$ or V_{IN-}	130	150	170	120	150	180	mV
	Pin 4 = 0.5V, $V_{CM} = V_{IN+}$ or V_{IN-}	40	50	60	30	50	70	
Threshold Supply Sensitivity	Pin 4 Open, $V_{CM} = V_{IN-}$, $V_{IN+} = 5$ to 35V		-0.1	-0.3		-0.1	-0.5	%/V
Adj. Input Current	Pin 4 = 0.5V		-2	-10		-2	-10	μA
Sense Input Bias Current	$V_{CM} = V_{IN+}$		100	200		100	200	μA
	$V_{CM} = V_{IN-}$		-100	-200		-100	-200	

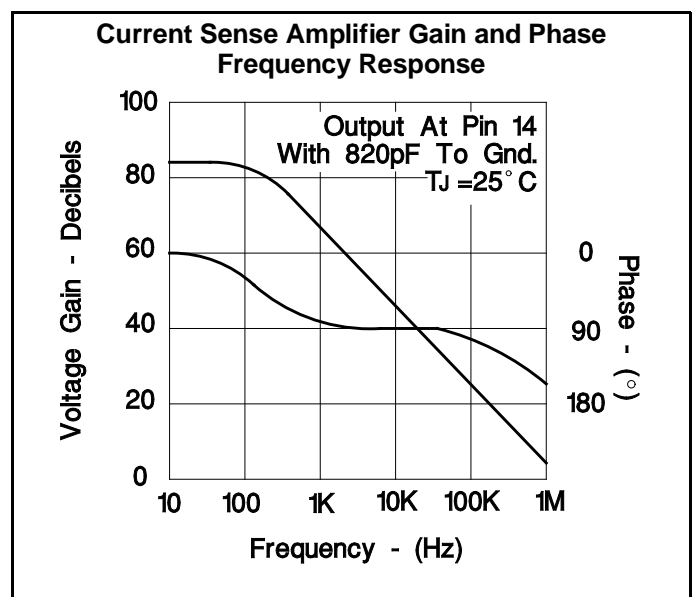
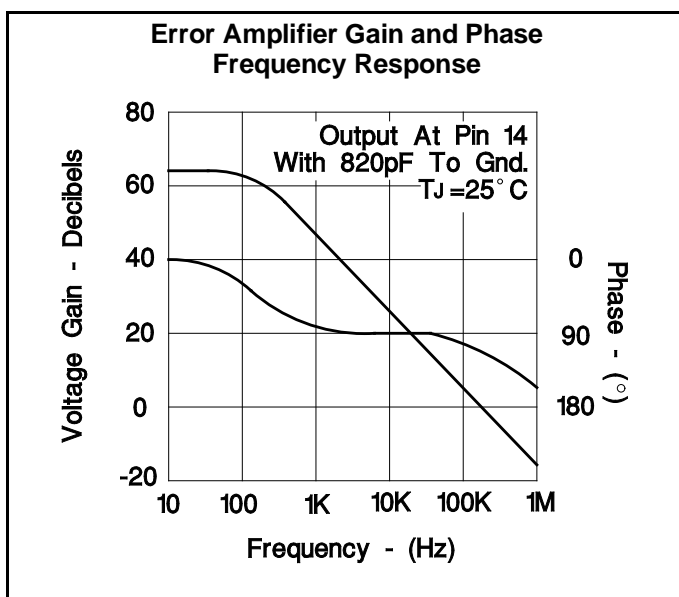
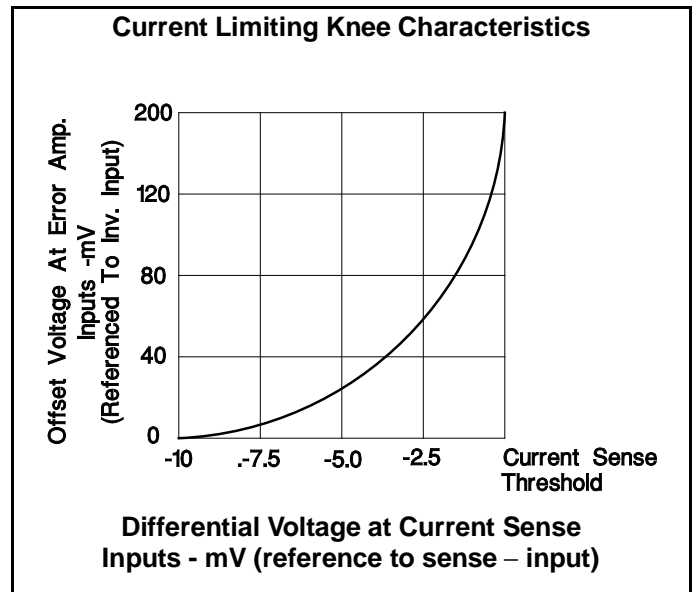
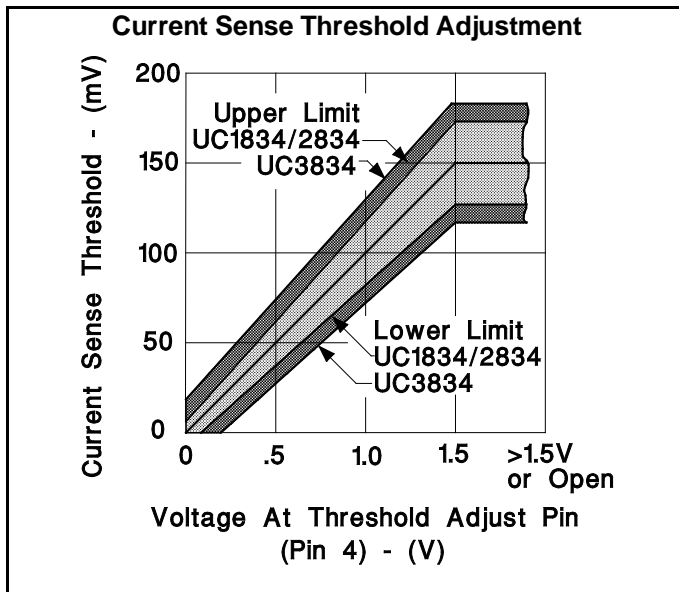

APPLICATION INFORMATION

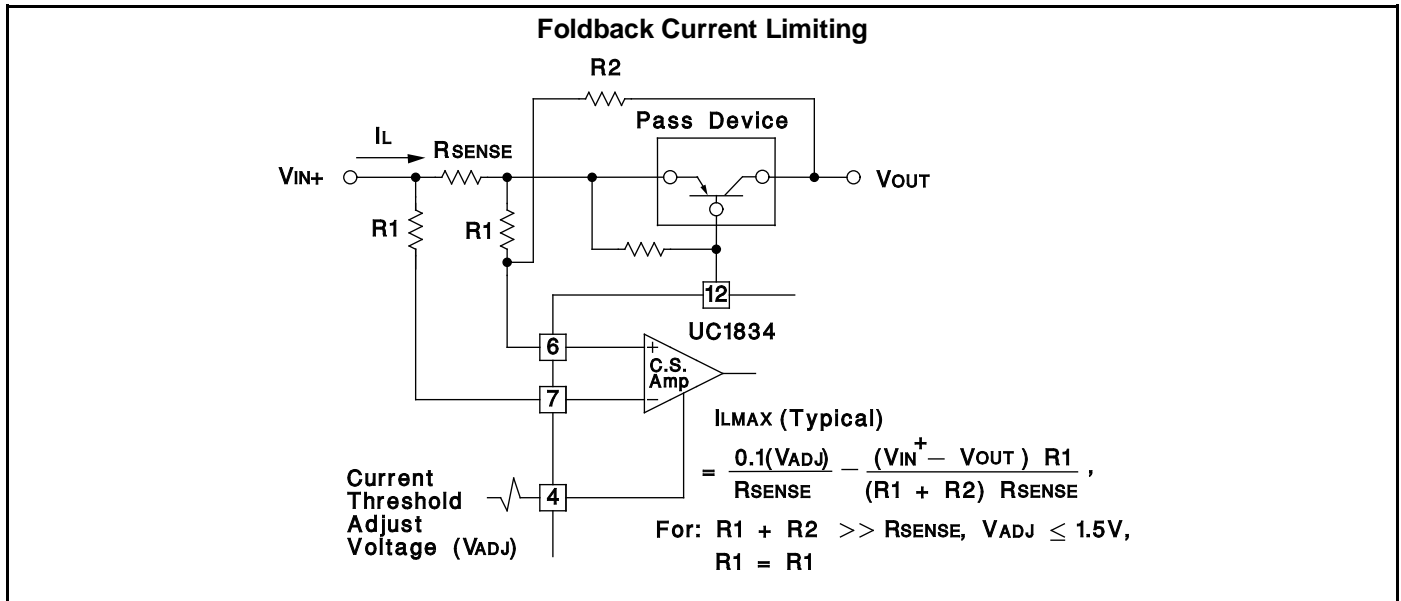

Both the current sense and error amplifiers on the UC1834 are transconductance type amplifiers. As a result, their voltage gain is a direct function of the load impedance at their shared output pin, Pin 14. Their small signal voltage gain as a function of load and frequency is nominally given by;

$$A_{V E/A} = \frac{Z_L(f)}{700\Omega} \text{ and } A_{V C.S./A} = \frac{Z_L(f)}{70\Omega}$$

for: $f \leq 500kHz$ and $|Z_L(f)| \leq 1 M\Omega$

Where:

- A_v = Small Signal Voltage Gain to pin 14.
- $Z_L(f)$ = Load Impedance at Pin 14.

The UC1834 fault delay circuitry prevents the fault outputs from responding to transient fault conditions. The delay reset latch insures that the full, user defined, delay passes before an over-voltage fault response occurs. This prevents unnecessary crowbar, or latched-off conditions, from occurring following sharp under-voltage to over-voltage transients.

The crowbar output on the UC1834 is activated following a sustained over-voltage condition. The crowbar output remains high as long as the fault condition persists, or, as long as the over-voltage latch is set. The latch is set with an over-voltage fault if the voltage at Pin 15 is above the latch reset threshold, typically 0.4V. When the latch is set, its Q- output will pull Pin 15 low through a series diode. As long as a nominal pull-up load exists, the series diode prevents Q- from pulling Pin 15 below the reset threshold. However, Pin 15 is pulled low enough to disable the driver outputs if Pins 15 and 14 are tied together. With Pin 15 and 14 common, the regulator will latch off in response to an over-voltage fault. If the fault condition is cleared and Pins 14 and 15 are momentarily pulled below the latch reset threshold, the driver outputs are re-enabled.

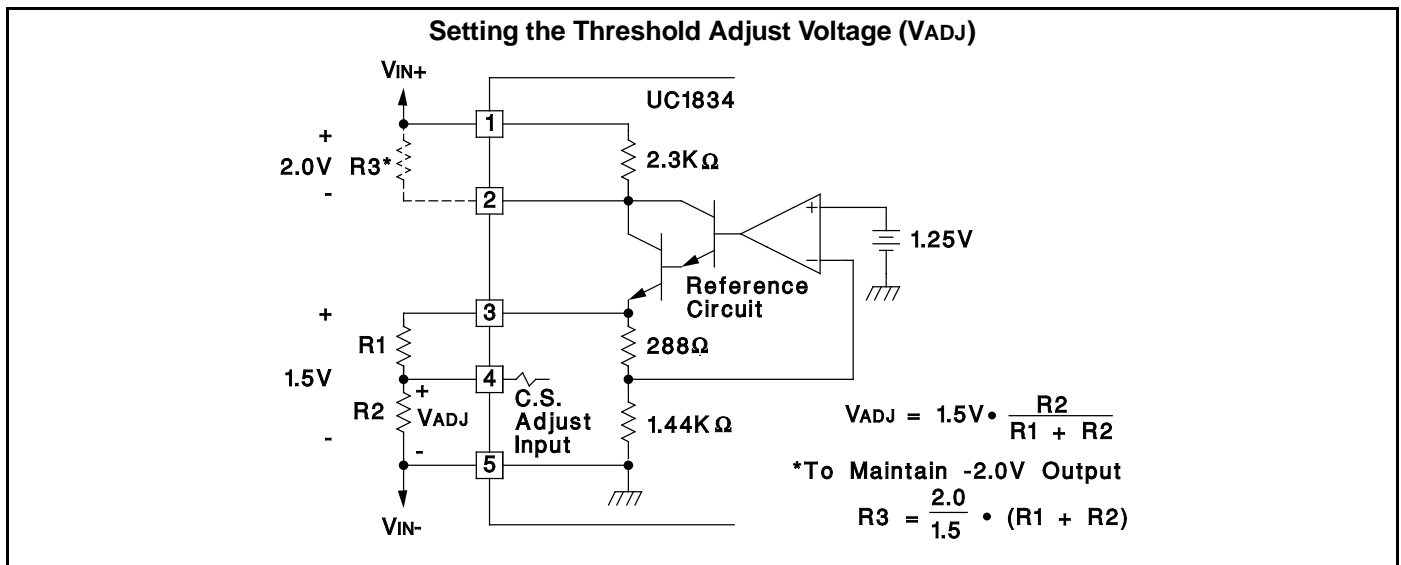

TYPICAL APPLICATIONS

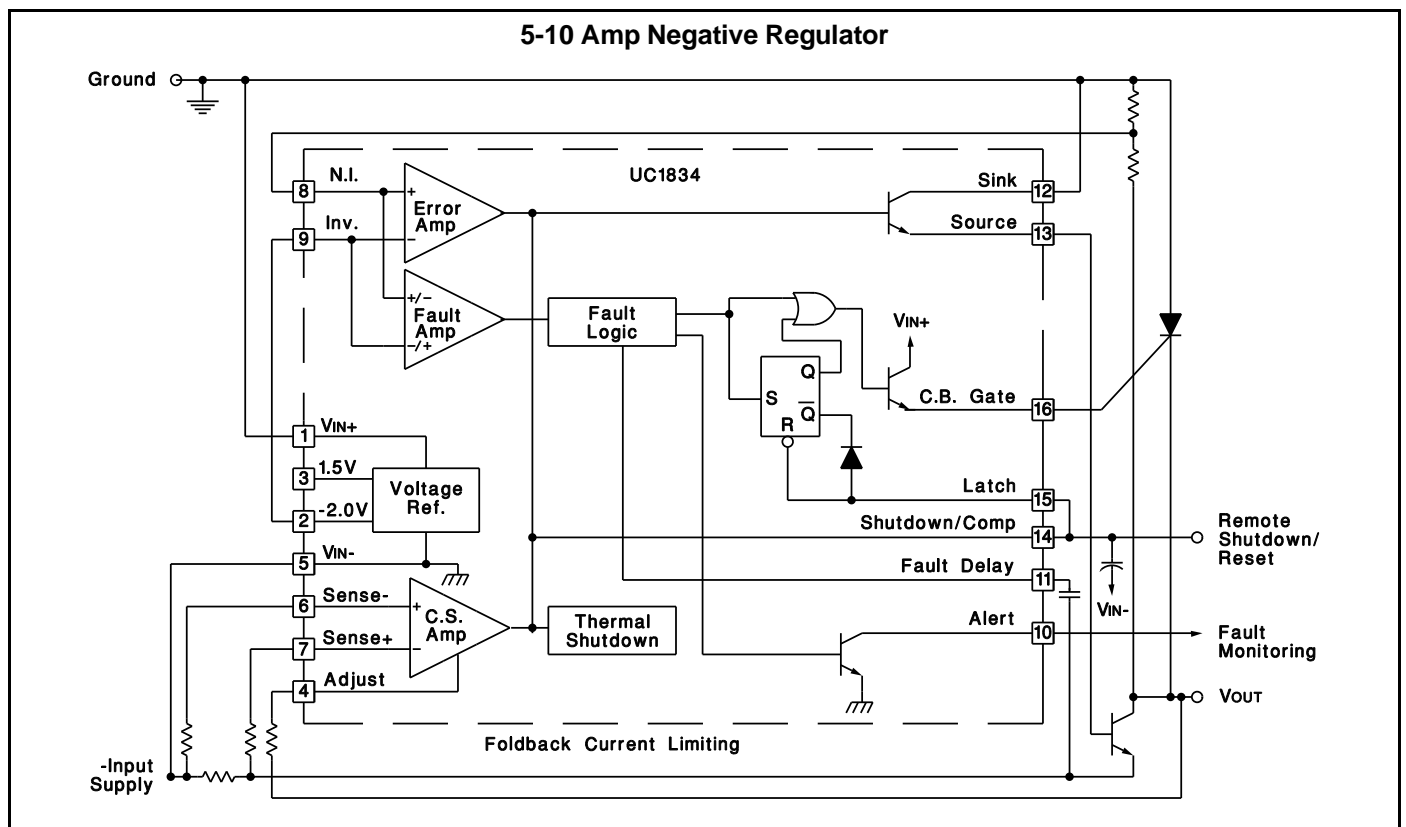
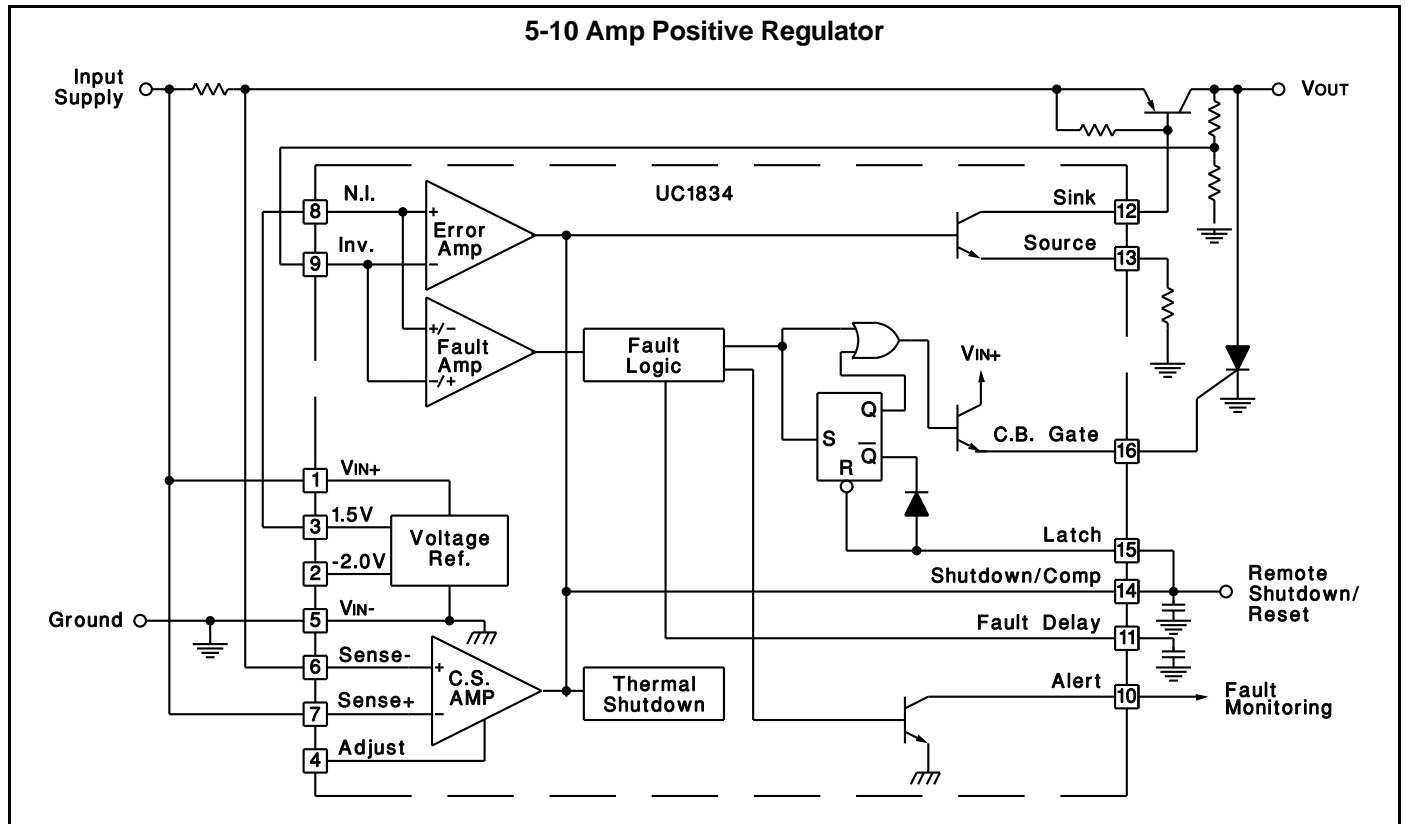

PACKAGING INFORMATION

Orderable Device	Status (1)	Package Type	Package Drawing	Pins	Package Qty	Eco Plan (2)	Lead/Ball Finish (6)	MSL Peak Temp (3)	Op Temp (°C)	Device Marking (4/5)	Samples
5962-87742012A	ACTIVE	LCCC	FK	20	1	TBD	POST-PLATE	N / A for Pkg Type	-55 to 125	5962- 87742012A UC1834L/ 883B	Samples
5962-8774201EA	ACTIVE	CDIP	J	16	1	TBD	A42	N / A for Pkg Type	-55 to 125	5962-8774201EA UC1834J/883B	Samples
5962-8774201V2A	ACTIVE	LCCC	FK	20	1	TBD	POST-PLATE	N / A for Pkg Type	-55 to 125	5962- 8774201V2A UC1834L QMLV	Samples
5962-8774201VEA	ACTIVE	CDIP	J	16	1	TBD	A42	N / A for Pkg Type	-55 to 125	5962-8774201VE A UC1834JQMLV	Samples
UC1834J	ACTIVE	CDIP	J	16	1	TBD	A42	N / A for Pkg Type	-55 to 125	UC1834J	Samples
UC1834J883B	ACTIVE	CDIP	J	16	1	TBD	A42	N / A for Pkg Type	-55 to 125	5962-8774201EA UC1834J/883B	Samples
UC1834L	ACTIVE	LCCC	FK	20	1	TBD	POST-PLATE	N / A for Pkg Type	-55 to 125	UC1834L	Samples
UC1834L883B	ACTIVE	LCCC	FK	20	1	TBD	POST-PLATE	N / A for Pkg Type	-55 to 125	5962- 87742012A UC1834L/ 883B	Samples
UC2834DW	ACTIVE	SOIC	DW	16	40	Green (RoHS & no Sb/Br)	CU NIPDAU	Level-2-260C-1 YEAR	-40 to 85	UC2834DW	Samples
UC2834DWG4	ACTIVE	SOIC	DW	16	40	Green (RoHS & no Sb/Br)	CU NIPDAU	Level-2-260C-1 YEAR	-40 to 85	UC2834DW	Samples
UC2834J	ACTIVE	CDIP	J	16	1	TBD	A42	N / A for Pkg Type	-40 to 85	UC2834J	Samples
UC3834DW	ACTIVE	SOIC	DW	16	40	Green (RoHS & no Sb/Br)	CU NIPDAU	Level-2-260C-1 YEAR	0 to 70	UC3834DW	Samples

(1) The marketing status values are defined as follows:

ACTIVE: Product device recommended for new designs.

LIFEBUY: TI has announced that the device will be discontinued, and a lifetime-buy period is in effect.

NRND: Not recommended for new designs. Device is in production to support existing customers, but TI does not recommend using this part in a new design.

PREVIEW: Device has been announced but is not in production. Samples may or may not be available.

OBSOLETE: TI has discontinued the production of the device.

(2) **RoHS:** TI defines "RoHS" to mean semiconductor products that are compliant with the current EU RoHS requirements for all 10 RoHS substances, including the requirement that RoHS substance do not exceed 0.1% by weight in homogeneous materials. Where designed to be soldered at high temperatures, "RoHS" products are suitable for use in specified lead-free processes. TI may reference these types of products as "Pb-Free".

RoHS Exempt: TI defines "RoHS Exempt" to mean products that contain lead but are compliant with EU RoHS pursuant to a specific EU RoHS exemption.

Green: TI defines "Green" to mean the content of Chlorine (Cl) and Bromine (Br) based flame retardants meet JS709B low halogen requirements of <=1000ppm threshold. Antimony trioxide based flame retardants must also meet the <=1000ppm threshold requirement.

(3) **MSL, Peak Temp.** - The Moisture Sensitivity Level rating according to the JEDEC industry standard classifications, and peak solder temperature.

(4) There may be additional marking, which relates to the logo, the lot trace code information, or the environmental category on the device.

(5) Multiple Device Markings will be inside parentheses. Only one Device Marking contained in parentheses and separated by a "~" will appear on a device. If a line is indented then it is a continuation of the previous line and the two combined represent the entire Device Marking for that device.

(6) **Lead/Ball Finish** - Orderable Devices may have multiple material finish options. Finish options are separated by a vertical ruled line. Lead/Ball Finish values may wrap to two lines if the finish value exceeds the maximum column width.

Important Information and Disclaimer: The information provided on this page represents TI's knowledge and belief as of the date that it is provided. TI bases its knowledge and belief on information provided by third parties, and makes no representation or warranty as to the accuracy of such information. Efforts are underway to better integrate information from third parties. TI has taken and continues to take reasonable steps to provide representative and accurate information but may not have conducted destructive testing or chemical analysis on incoming materials and chemicals. TI and TI suppliers consider certain information to be proprietary, and thus CAS numbers and other limited information may not be available for release.

In no event shall TI's liability arising out of such information exceed the total purchase price of the TI part(s) at issue in this document sold by TI to Customer on an annual basis.

OTHER QUALIFIED VERSIONS OF UC1834, UC1834-SP, UC2834, UC2834M, UC3834 :

- Catalog: [UC3834](#), [UC1834](#), [UC2834](#)

- Military: [UC2834M](#), [UC1834](#)

- Space: [UC1834-SP](#)

NOTE: Qualified Version Definitions:

- Catalog - TI's standard catalog product

- Military - QML certified for Military and Defense Applications
- Space - Radiation tolerant, ceramic packaging and qualified for use in Space-based application

IMPORTANT NOTICE AND DISCLAIMER

TI PROVIDES TECHNICAL AND RELIABILITY DATA (INCLUDING DATASHEETS), DESIGN RESOURCES (INCLUDING REFERENCE DESIGNS), APPLICATION OR OTHER DESIGN ADVICE, WEB TOOLS, SAFETY INFORMATION, AND OTHER RESOURCES "AS IS" AND WITH ALL FAULTS, AND DISCLAIMS ALL WARRANTIES, EXPRESS AND IMPLIED, INCLUDING WITHOUT LIMITATION ANY IMPLIED WARRANTIES OF MERCHANTABILITY, FITNESS FOR A PARTICULAR PURPOSE OR NON-INFRINGEMENT OF THIRD PARTY INTELLECTUAL PROPERTY RIGHTS.

These resources are intended for skilled developers designing with TI products. You are solely responsible for (1) selecting the appropriate TI products for your application, (2) designing, validating and testing your application, and (3) ensuring your application meets applicable standards, and any other safety, security, or other requirements. These resources are subject to change without notice. TI grants you permission to use these resources only for development of an application that uses the TI products described in the resource. Other reproduction and display of these resources is prohibited. No license is granted to any other TI intellectual property right or to any third party intellectual property right. TI disclaims responsibility for, and you will fully indemnify TI and its representatives against, any claims, damages, costs, losses, and liabilities arising out of your use of these resources.

TI's products are provided subject to TI's Terms of Sale (www.ti.com/legal/termsofsale.html) or other applicable terms available either on ti.com or provided in conjunction with such TI products. TI's provision of these resources does not expand or otherwise alter TI's applicable warranties or warranty disclaimers for TI products.

Mailing Address: Texas Instruments, Post Office Box 655303, Dallas, Texas 75265
Copyright © 2019, Texas Instruments Incorporated

Looking for pricing, stock, or lifecycle information?

Click below to explore more details on WIN SOURCE:

 [View UC2834DW](#) on WIN SOURCE

 [Texas Instruments](#) Information

Optimize Your Supply Chain with WIN SOURCE Solutions

-  Global Sourcing Solution
-  Obsolete Management
-  Cost Control Management
-  Shortage Management
-  Alternative Solution
-  Excess Inventory Management