



**THE DATASHEET OF  
SN74GTLPH16927VR**



## FEATURES

- Member of the Texas Instruments Widebus™ Family
- TI-OPC™ Circuitry Limits Ringing on Unevenly Loaded Backplanes
- OEC™ Circuitry Improves Signal Integrity and Reduces Electromagnetic Interference
- Bidirectional Interface Between GTLP Signal Levels and LVTTL Logic Levels
- GTLP Buffered SYSCLK Signal (SSCLK) for Source-Synchronous Applications
- LVTTL Interfaces Are 5-V Tolerant
- Medium-Drive GTLP Outputs (50 mA)
- LVTTL Outputs (–24 mA/24 mA)
- GTLP Rise and Fall Times Designed for Optimal Data-Transfer Rate and Signal Integrity in Distributed Loads
- $I_{off}$ , Power-Up 3-State, and BIAS  $V_{CC}$  Support Live Insertion
- Bus Hold on A-Port Data Inputs
- Distributed  $V_{CC}$  and GND Pins Minimize High-Speed Switching Noise
- Latch-Up Performance Exceeds 100 mA Per JESD 78, Class II
- ESD Protection Exceeds JESD 22
  - 2000-V Human-Body Model (A114-A)
  - 200-V Machine Model (A115-A)
  - 1000-V Charged-Device Model (C101)

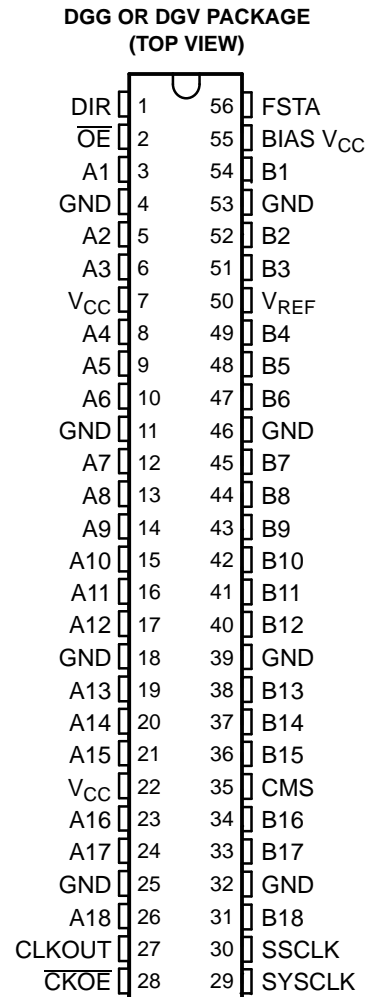

## DESCRIPTION/ORDERING INFORMATION

The SN74GTLPH16927 is a medium-drive, 18-bit bus transceiver that provides LVTTL-to-GTLP and GTLP-to-LVTTL signal-level translation. The device allows for transparent and latched modes of data transfer. Additionally, with the use of the clock-mode select (CMS) input, the device can be used in source-synchronous and clock-synchronous applications. Source-synchronous applications require the skew between the clock output and data output to be minimized for optimum maximum-frequency system performance. In order to reduce this skew, a flexible setup-time adjustment (FSTA) feature is incorporated into the device that sets a predetermined delay between the clock and data. The CMS and direction (DIR) inputs control the mode of the device.

### ORDERING INFORMATION

$T_A$	PACKAGE <sup>(1)</sup>		ORDERABLE PART NUMBER	TOP-SIDE MARKING
–40°C to 85°C	TSSOP – DGG	Tape and reel	SN74GTLPH16927GR	GTLPH16927
	TVSOP – DGV	Tape and reel	SN74GTLPH16927VR	GL927
	VFBGA – GQL	Tape and reel	SN74GTLPH16927KR	GL927

(1) Package drawings, standard packing quantities, thermal data, symbolization, and PCB design guidelines are available at [www.ti.com/sc/package](http://www.ti.com/sc/package).



Please be aware that an important notice concerning availability, standard warranty, and use in critical applications of Texas Instruments semiconductor products and disclaimers thereto appears at the end of this data sheet.

Widebus, TI-OPC, OEC are trademarks of Texas Instruments.

# SN74GTLPH16927

## 18-BIT LVTTL-TO-GTLP BUS TRANSCEIVER WITH SOURCE-SYNCHRONOUS CLOCK OUTPUTS

SCES413–OCTOBER 2002–REVISED JUNE 2005

---

### DESCRIPTION/ORDERING INFORMATION (CONTINUED)

The system clock (SYSCLK) and CLKOUT pins are LVTTL compatible, while the source-synchronous I/O is GTLP compatible. The benefits include compensation for output-to-output skew coming from the driver itself, and compensation for process skew if more than one driver is used. The device provides a high-speed interface between cards operating at LVTTL logic levels and a backplane operating at GTLP signal levels. High-speed (about three times faster than standard TTL or LVTTL) backplane operation is a direct result of GTLP's reduced output swing ( $<1$  V), reduced input threshold levels, improved differential input, OEC™ circuitry, and TI-OPC™ circuitry. Improved GTLP OEC and TI-OPC circuits minimize bus-settling time and have been designed and tested using several backplane models. The medium drive allows incident-wave switching in heavily loaded backplanes with equivalent load impedance down to  $11 \Omega$ .

GTLP is the Texas Instruments derivative of the Gunning Transceiver Logic (GTL) JEDEC standard JESD 8-3. The ac specification of the SN74GTLPH16927 is given only at the preferred higher noise-margin GTLP, but the user has the flexibility of using this device at either GTL ( $V_{TT} = 1.2$  V and  $V_{REF} = 0.8$  V) or GTLP ( $V_{TT} = 1.5$  V and  $V_{REF} = 1$  V) signal levels. For information on using GTLP devices in FB+/BTL applications, refer to TI application reports, *Texas Instruments GTLP Frequently Asked Questions*, literature number SCEA019, and *GTLP in BTL Applications*, literature number SCEA017.

Normally, the B port operates at GTLP signal levels. The A-port and control inputs operate at LVTTL logic levels, but are 5-V tolerant and are compatible with TTL and 5-V CMOS inputs.  $V_{REF}$  is the B-port differential input reference voltage.

This device is fully specified for live-insertion applications using  $I_{off}$ , power-up 3-state, and BIAS  $V_{CC}$ . The  $I_{off}$  circuitry disables the outputs, preventing damaging current backflow through the device when it is powered down. The power-up 3-state circuitry places the outputs in the high-impedance state during power up and power down, which prevents driver conflict. The BIAS  $V_{CC}$  circuitry precharges and preconditions the B-port input/output connections, preventing disturbance of active data on the backplane during card insertion or removal, and permits true live-insertion capability.

This GTLP device features TI-OPC circuitry, which actively limits the overshoot caused by improperly terminated backplanes, unevenly distributed cards, or empty slots during low-to-high signal transitions. This improves signal integrity, which allows adequate noise margin to be maintained at higher frequencies.

Active bus-hold circuitry holds unused or undriven LVTTL data inputs at a valid logic state. Use of pullup or pulldown resistors with the bus-hold circuitry is not recommended.

When  $V_{CC}$  is between 0 and 1.5 V, the device is in the high-impedance state during power up or power down. However, to ensure the high-impedance state above 1.5 V, the output-enable ( $\overline{OE}$ ) input should be tied to  $V_{CC}$  through a pullup resistor; the minimum value of the resistor is determined by the current-sinking capability of the driver.

**GQL PACKAGE  
(TOP VIEW)**

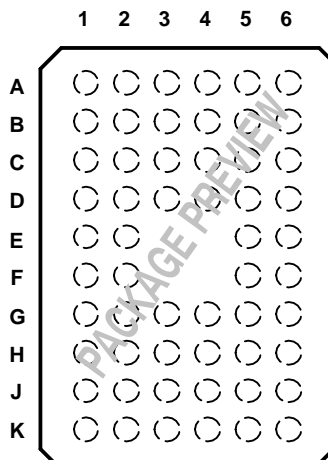

**TERMINAL ASSIGNMENTS**

	1	2	3	4	5	6
<b>A</b>	A1	$\overline{OE}$	DIR	FSTA	BIAS $V_{CC}$	B1
<b>B</b>	A3	A2	GND	GND	B2	B3
<b>C</b>	A5	A4	$V_{CC}$	$V_{REF}$	B4	B5
<b>D</b>	A7	A6	GND	GND	B6	B7
<b>E</b>	A9	A8			B8	B9
<b>F</b>	A10	A11			B11	B10
<b>G</b>	A12	A13	GND	GND	B13	B12
<b>H</b>	A14	A15	$V_{CC}$	CMS	B15	B14
<b>J</b>	A16	A17	GND	GND	B17	B16
<b>K</b>	A18	CLKOUT	$\overline{CKOE}$	SYSCLK	SSCLK	B18

# SN74GTLPH16927 18-BIT LVTTTL-TO-GTLP BUS TRANSCEIVER WITH SOURCE-SYNCHRONOUS CLOCK OUTPUTS

SCES413–OCTOBER 2002–REVISED JUNE 2005

## FUNCTIONAL DESCRIPTION

The SN74GTLPH16927 is a medium-drive (50 mA), 18-bit bus transceiver containing D-type latches and D-type flip-flops for data-path operation in transparent or latched modes and can replace any of the functions shown in Table 1. Data polarity is noninverting.

**Table 1. SN74GTLPH16927 Bus-Transceiver Replacement Functions**

FUNCTION	8 BIT	9 BIT	10 BIT	16 BIT	18 BIT
Transceiver	'245, '623, '645	'863	'861	'16245, '16623	'16863
Buffer/driver	'241, '244, '541		'827	'16241, '16244, '16541	'16825
Latched transceiver	'543			'16543	'16472
Latch	'373, '573	'843	'841	'16373	'16843
SN74GTLPH16927 bus transceiver replaces all above functions					

Additionally, the device allows for conversion of the system clock (SYSCLK) to GTLP signal levels (SSCLK) and LVTTTL signal levels (CLKOUT). It also provides conversion of a GTLP source-synchronous clock to LVTTTL signal levels (CLKOUT).

The device allows for conversion of the LVTTTL system clock (SYSCLK) to GTLP (SSCLK) and LVTTTL (CLKOUT) signal levels when used as the transmitter and GTLP source-synchronous clock (SSCLK) to LVTTTL (CLKOUT) signal levels when used as the receiver in source-synchronous applications. Source-synchronous operation removes time-of-flight restrictions and allows for increased data throughput. CMS is used to switch between system-synchronous mode and clock-synchronous mode. The clock output-enable ( $\overline{\text{CKOE}}$ ) input is used to switch between latched and transparent mode.

Data flow in each direction is controlled by  $\overline{\text{CKOE}}$ , clock (SYSCLK or SSCLK), DIR, and  $\overline{\text{OE}}$ .  $\overline{\text{OE}}$  controls the 18 bits of data. The CLKOUT/SSCLK buffered clock path for the A-to-B and B-to-A directions is controlled by  $\overline{\text{CKOE}}$ . In the data-isolation mode ( $\overline{\text{OE}}$  high,  $\overline{\text{CKOE}}$  low), A data can be stored in one register and/or B data can be stored in the other register.

**LOGIC DIAGRAM (POSITIVE LOGIC)<sup>(1)</sup>**

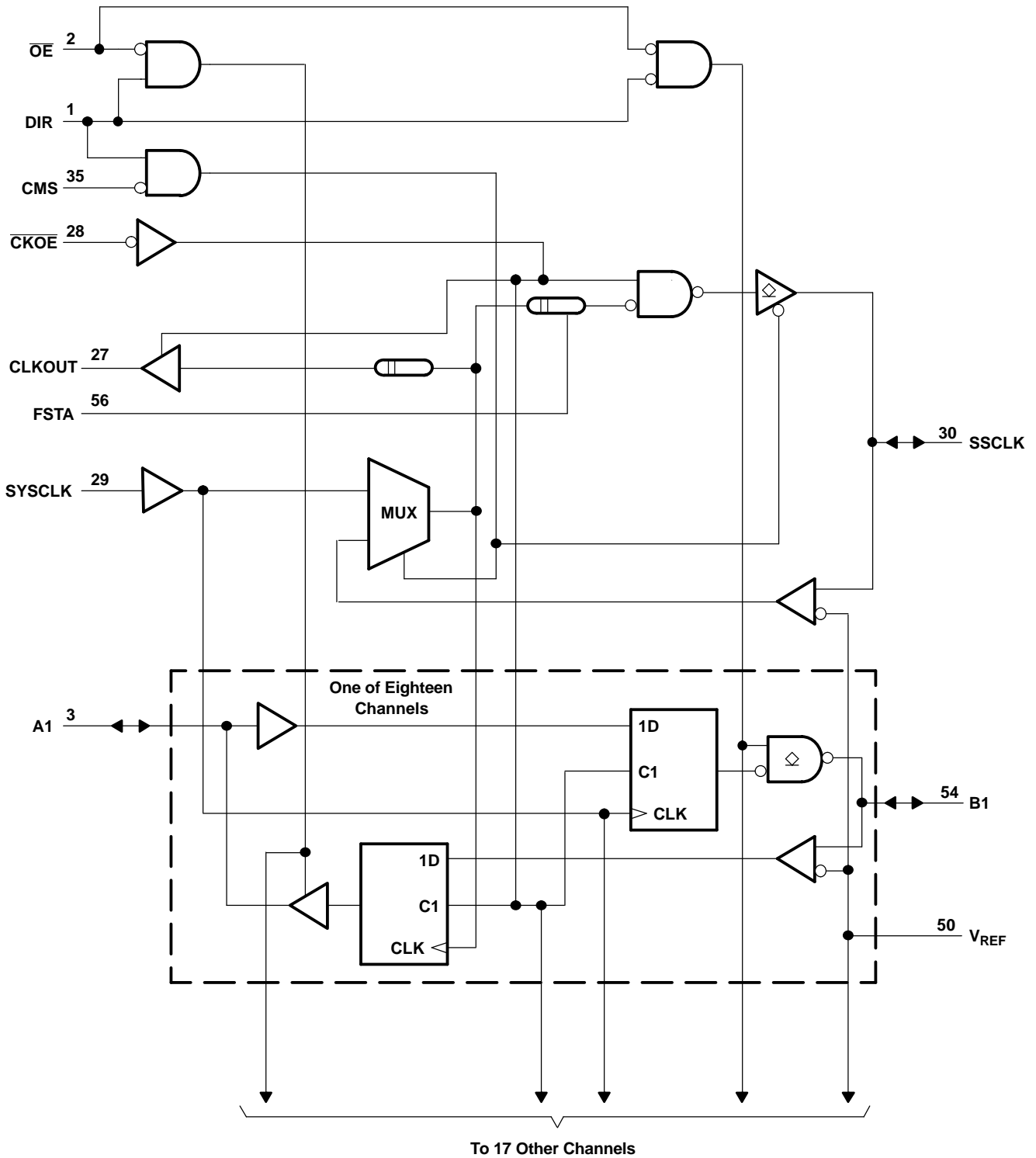

(1) Pin numbers shown are for the DGG and DGV packages.

**SN74GTLPH16927**  
**18-BIT LVTTTL-TO-GTLP BUS TRANSCEIVER**  
**WITH SOURCE-SYNCHRONOUS CLOCK OUTPUTS**

SCES413–OCTOBER 2002–REVISED JUNE 2005

**FUNCTION TABLES**

**A-TO-B DIRECTION**

INPUTS						OUTPUTS			MODE	
CKOE	OE	CMS	DIR	SYSCLK	A	SSCLK	CLKOUT	B		
L	L	X	L	H or L	X	SYSCLK	SYSCLK	B <sub>1</sub>	Latched storage of A	Source synchronous
L	L	X	L	↑	L	SYSCLK	SYSCLK	L	Clocked storage of A	
L	L	X	L	↑	H	SYSCLK	SYSCLK	H		
L	H	X	L	X	X	SYSCLK	SYSCLK	Z	Data isolation	
H	L	X	L	X	L	Z	Z	L	Transparent transmission of A	
H	L	X	L	X	H	Z	Z	H		
H	H	X	X	X	X	Z	Z	Z	Isolation	
L	H	H	X	↑	X	SYSCLK	SYSCLK	Z	Transmit SYSCLK	
L	H	H	X	H or L	X	SYSCLK	SYSCLK	Z		

**B-TO-A DIRECTION**

INPUTS							OUTPUTS			MODE	
CKOE	OE	CMS	DIR	SYSCLK	SSCLK	B	SSCLK	CLKOUT	A		
L	L	L	H	X	H or L	X	Input	SSCLK	A <sub>1</sub>	Latched storage of B	Source synchronous
L	L	L	H	X	↑	L	Input	SSCLK	L	Clocked storage of B	
L	L	L	H	X	↑	H	Input	SSCLK	H		
L	H	L	H	X	X	X	Input	SSCLK	Z	Data isolation	
L	L	H	H	H or L	Output	X	SYSCLK	SYSCLK	A <sub>1</sub>	Latched storage of B	Clock synchronous
L	L	H	H	↑	Output	L	SYSCLK	SYSCLK	L	Clocked storage of B	
L	L	H	H	↑	Output	H	SYSCLK	SYSCLK	H		
L	H	H	H	X	Output	X	SYSCLK	SYSCLK	Z	Data isolation	
H	L	X	H	X	Output	L	Z	Z	L	Transparent transmission of B	
H	L	X	H	X	Output	H	Z	Z	H		
H	H	X	X	X	Output	X	Z	Z	Z	Isolation	
L	H	L	X	X	↑	X	Input	SSCLK	Z	Receive SSCLK	
L	H	L	X	X	H or L	X	Input	SSCLK	Z		

**Absolute Maximum Ratings<sup>(1)</sup>**

over operating free-air temperature range (unless otherwise noted)

		MIN	MAX	UNIT	
$V_{CC}$ BIAS $V_{CC}$	Supply voltage range	−0.5	4.6	V	
$V_I$	Input voltage range <sup>(2)</sup>	A-port and control inputs	−0.5	7	V
		B port and $V_{REF}$	−0.5	4.6	
$V_O$	Voltage range applied to any output in the high-impedance or power-off state <sup>(2)</sup>	A port	−0.5	7	V
		B port	−0.5	4.6	
$I_O$	Current into any output in the low state	A port		48	mA
		B port		100	
$I_O$	Current into any A-port output in the high state <sup>(3)</sup>		48	mA	
	Continuous current through each $V_{CC}$ or GND		±100	mA	
$I_{IK}$	Input clamp current	$V_I < 0$	−50	mA	
$I_{OK}$	Output clamp current	$V_O < 0$	−50	mA	
$\theta_{JA}$	Package thermal impedance <sup>(4)</sup>	DGG package		64	°C/W
		DGV package		48	
		GQL package		42	
$T_{stg}$	Storage temperature range	−65	150	°C	

- (1) Stresses beyond those listed under "absolute maximum ratings" may cause permanent damage to the device. These are stress ratings only, and functional operation of the device at these or any other conditions beyond those indicated under "recommended operating conditions" is not implied. Exposure to absolute-maximum-rated conditions for extended periods may affect device reliability.
- (2) The input and output negative-voltage ratings may be exceeded if the input and output clamp-current ratings are observed.
- (3) This current flows only when the output is in the high state and  $V_O > V_{CC}$ .
- (4) The package thermal impedance is calculated in accordance with JESD 51-7.

**SN74GTLPH16927**  
**18-BIT LVTTTL-TO-GTLP BUS TRANSCEIVER**  
**WITH SOURCE-SYNCHRONOUS CLOCK OUTPUTS**



SCES413–OCTOBER 2002–REVISED JUNE 2005

**Recommended Operating Conditions**<sup>(1)(2)(3)(4)</sup>

			MIN	NOM	MAX	UNIT
$V_{CC}$ BIAS $V_{CC}$	Supply voltage		3.15	3.3	3.45	V
$V_{TT}$	Termination voltage	GTL	1.14	1.2	1.26	V
		GTLP	1.35	1.5	1.65	
$V_{REF}$	Reference voltage	GTL	0.74	0.8	0.87	V
		GTLP	0.87	1	1.1	
$V_I$	Input voltage	B port and SSCLK			$V_{TT}$	V
		Except B port and SSCLK		$V_{CC}$	5.5	
$V_{IH}$	High-level input voltage	B port and SSCLK	$V_{REF} + 0.05$			V
		Except B port, FSTA, and SSCLK	2			
$V_{IL}$	Low-level input voltage	B port and SSCLK			$V_{REF} - 0.05$	V
		Except B port, FSTA, and SSCLK			0.8	
$I_{IK}$	Input clamp current				-18	mA
$I_{OH}$	High-level output current	A port and CLKOUT			-24	mA
$I_{OL}$	Low-level output current	A port and CLKOUT			24	mA
		B port and SSCLK			50	
$\Delta t/\Delta v$	Input transition rise or fall rate	Outputs enabled			10	ns/V
$\Delta t/\Delta V_{CC}$	Power-up ramp rate		20			$\mu$ s/V
$T_A$	Operating free-air temperature		-40		85	$^{\circ}$ C

- (1) All unused inputs of the device must be held at  $V_{CC}$  or GND to ensure proper device operation. Refer to the TI application report, *Implications of Slow or Floating CMOS Inputs*, literature number SCBA004.
- (2) Proper connection sequence for use of the B-port I/O precharge feature is GND and BIAS  $V_{CC} = 3.3$  V first, I/O second, and  $V_{CC} = 3.3$  V last, because the BIAS  $V_{CC}$  precharge circuitry is disabled when any  $V_{CC}$  pin is connected. The control and  $V_{REF}$  inputs can be connected anytime, but normally are connected during the I/O stage. If B-port precharge is not required, any connection sequence is acceptable but, generally, GND is connected first.
- (3)  $V_{TT}$  and  $R_{TT}$  can be adjusted to accommodate backplane impedances if the dc recommended  $I_{OL}$  ratings are not exceeded.
- (4)  $V_{REF}$  can be adjusted to optimize noise margins, but normally is two-thirds  $V_{TT}$ . TI-OPC circuitry is enabled in the A-to-B direction and is activated when  $V_{TT} > 0.7$  V above  $V_{REF}$ . If operated in the A-to-B direction,  $V_{REF}$  should be set to within 0.6 V of  $V_{TT}$  to minimize current drain.

## Electrical Characteristics

over recommended operating free-air temperature range for GTLP (unless otherwise noted)

PARAMETER		TEST CONDITIONS		MIN	TYP <sup>(1)</sup>	MAX	UNIT
$V_{IK}$		$V_{CC} = 3.15\text{ V}$ ,	$I_I = -18\text{ mA}$			-1.2	V
$V_{OH}$	A port and CLKOUT	$V_{CC} = 3.15\text{ V to } 3.45\text{ V}$ ,	$I_{OH} = -100\text{ }\mu\text{A}$	$V_{CC} - 0.2$			V
		$V_{CC} = 3.15\text{ V}$	$I_{OH} = -12\text{ mA}$	2.4			
			$I_{OH} = -24\text{ mA}$	2			
$V_{OL}$	A port and CLKOUT	$V_{CC} = 3.15\text{ V to } 3.45\text{ V}$ ,	$I_{OL} = 100\text{ }\mu\text{A}$			0.2	V
		$V_{CC} = 3.15\text{ V}$	$I_{OL} = 12\text{ mA}$			0.4	
			$I_{OL} = 24\text{ mA}$			0.5	
	B port and SSCLK	$V_{CC} = 3.15\text{ V to } 3.45\text{ V}$ ,	$I_{OL} = 100\text{ }\mu\text{A}$			0.2	
		$V_{CC} = 3.15\text{ V}$	$I_{OL} = 10\text{ mA}$			0.2	
			$I_{OL} = 40\text{ mA}$			0.4	
		$I_{OL} = 50\text{ mA}$			0.55		
$I_I$	SYSCLK and control inputs	$V_{CC} = 3.45\text{ V}$ ,	$V_I = 0\text{ to } 5.5\text{ V}$			$\pm 10$	$\mu\text{A}$
$I_{OZ}^{(2)}$	B port and SSCLK	$V_{CC} = 3.45\text{ V}$ , $V_{REF}$ within 0.6 V of $V_{TT}$ ,	$V_O = 0\text{ to } 2.3\text{ V}$			$\pm 10$	$\mu\text{A}$
	CLKOUT	$V_{CC} = 3.45\text{ V}$ ,	$V_O = 0\text{ to } 5.5\text{ V}$			$\pm 10$	
$I_{OZH}^{(2)}$	A port	$V_{CC} = 3.45\text{ V}$ ,	$V_O = V_{CC}$			10	$\mu\text{A}$
$I_{OZL}^{(2)}$	A port	$V_{CC} = 3.45\text{ V}$ ,	$V_O = \text{GND}$			-10	$\mu\text{A}$
$I_{BHL}^{(3)}$	A port	$V_{CC} = 3.15\text{ V}$ ,	$V_I = 0.8\text{ V}$		75		$\mu\text{A}$
$I_{BHH}^{(4)}$	A port	$V_{CC} = 3.15\text{ V}$ ,	$V_I = 2\text{ V}$		-75		$\mu\text{A}$
$I_{BHLO}^{(5)}$	A port	$V_{CC} = 3.45\text{ V}$ ,	$V_I = 0\text{ to } V_{CC}$		500		$\mu\text{A}$
$I_{BHHO}^{(6)}$	A port	$V_{CC} = 3.45\text{ V}$ ,	$V_I = 0\text{ to } V_{CC}$		-500		$\mu\text{A}$
$I_{CC}$	A port, B port, or SSCLK	$V_{CC} = 3.45\text{ V}$ , $I_O = 0$ , $V_I$ (A-port or control input) = $V_{CC}$ or GND, $V_I$ (B port) = $V_{TT}$ or GND	Outputs high			50	mA
			Outputs low			50	
			Outputs disabled			50	
$\Delta I_{CC}^{(7)}$		$V_{CC} = 3.45\text{ V}$ , One A-port or control input at $V_{CC} - 0.6\text{ V}$ , Other A-port or control inputs at $V_{CC}$ or GND				1.5	mA
$C_i$	SYSCLK inputs	$V_I = 3.15\text{ V or } 0$			3.5	5	pF
	Control inputs	$V_I = 3.15\text{ V or } 0$			3.5	5.5	
$C_{io}$	A port	$V_O = 3.15\text{ V or } 0$			7.5	10	pF
	B port or SSCLK	$V_O = 1.5\text{ V or } 0$			9	11	
$C_o$	CLKOUT	$V_O = 3.15\text{ V or } 0$			6	7.5	pF

(1) All typical values are at  $V_{CC} = 3.3\text{ V}$ ,  $T_A = 25^\circ\text{C}$ .

(2) For I/O ports, the parameter  $I_I$  includes the off-state output leakage current.

(3) The bus-hold circuit can sink at least the minimum low sustaining current at  $V_{ILmax}$ .  $I_{BHL}$  should be measured after lowering  $V_{IN}$  to GND and then raising it to  $V_{ILmax}$ .

(4) The bus-hold circuit can source at least the minimum high sustaining current at  $V_{IHmin}$ .  $I_{BHH}$  should be measured after raising  $V_{IN}$  to  $V_{CC}$  and then lowering it to  $V_{IHmin}$ .

(5) An external driver must source at least  $I_{BHLO}$  to switch this node from low to high.

(6) An external driver must sink at least  $I_{BHHO}$  to switch this node from high to low.

(7) This is the increase in supply current for each input that is at the specified TTL voltage level, rather than  $V_{CC}$  or GND.

## Hot-Insertion Specifications for A Port

over recommended operating free-air temperature range

PARAMETER	TEST CONDITIONS			MIN	MAX	UNIT
$I_{off}$	$V_{CC} = 0$ ,	BIAS $V_{CC} = 0$ ,	$V_I$ or $V_O = 0\text{ to } 5.5\text{ V}$		10	$\mu\text{A}$
$I_{OZPU}$	$V_{CC} = 0\text{ to } 1.5\text{ V}$ ,	$V_O = 0.5\text{ V to } 3\text{ V}$ ,	$\overline{OE} = 0$		$\pm 30$	$\mu\text{A}$
$I_{OZPD}$	$V_{CC} = 1.5\text{ V to } 0$ ,	$V_O = 0.5\text{ V to } 3\text{ V}$ ,	$\overline{OE} = 0$		$\pm 30$	$\mu\text{A}$

**SN74GTLPH16927**  
**18-BIT LVTTTL-TO-GTLP BUS TRANSCEIVER**  
**WITH SOURCE-SYNCHRONOUS CLOCK OUTPUTS**

SCES413–OCTOBER 2002–REVISED JUNE 2005

**Live-Insertion Specifications for B Port**

over recommended operating free-air temperature range

PARAMETER	TEST CONDITIONS			MIN	MAX	UNIT
$I_{off}$	$V_{CC} = 0,$	BIAS $V_{CC} = 0,$	$V_I$ or $V_O = 0$ to 1.5 V		10	$\mu A$
$I_{OZPU}$	$V_{CC} = 0$ to 1.5 V,	BIAS $V_{CC} = 0,$	$V_O = 0.5$ V to 1.5 V, $\overline{OE} = 0$		$\pm 30$	$\mu A$
$I_{OZPD}$	$V_{CC} = 1.5$ V to 0,	BIAS $V_{CC} = 0,$	$V_O = 0.5$ V to 1.5 V, $\overline{OE} = 0$		$\pm 30$	$\mu A$
$I_{CC}$ (BIAS $V_{CC}$ )	$V_{CC} = 0$ to 3.15 V	BIAS $V_{CC} = 3.15$ V to 3.45 V,	$V_O$ (B port) = 0 to 1.5 V		5	mA
	$V_{CC} = 3.15$ V to 3.45 V				10	$\mu A$
$V_O$	$V_{CC} = 0,$	BIAS $V_{CC} = 3.3$ V,	$I_O = 0$	0.95	1.05	V
$I_O$	$V_{CC} = 0,$	BIAS $V_{CC} = 3.15$ V to 3.45 V,	$V_O$ (B port) = 0.6 V	-1		$\mu A$

**Timing Requirements**

over recommended ranges of supply voltage and operating free-air temperature,  
 $V_{TT} = 1.5$  V and  $V_{REF} = 1$  V for GTLP (unless otherwise noted)

			MIN	MAX	UNIT
$f_{clock}$	Clock frequency			175	MHz
$t_w$	Pulse duration	$\overline{CKOE}$ high		2.8	ns
		SYSCLK or SSCLK high or low		3.3	
$t_{su}$	Setup time	A before SYSCLK $\uparrow$		1.2	ns
		B before SYSCLK $\uparrow$ or SSCLK $\uparrow$		2.6	
		A before $\overline{CKOE}\downarrow$		1.2	
		B before $\overline{CKOE}\downarrow$		2.6	
$t_h$	Hold time	A after SYSCLK $\uparrow$		0.3	ns
		B after SYSCLK $\uparrow$ or SSCLK $\uparrow$		0.8	
		A after $\overline{CKOE}\downarrow$		1.1	
		B after $\overline{CKOE}\downarrow$		0.3	

## Switching Characteristics

over recommended ranges of supply voltage and operating free-air temperature,  
 $V_{TT} = 1.5\text{ V}$  and  $V_{REF} = 1\text{ V}$  for GTLP (see Figure 1)

PARAMETER	FROM (INPUT)	TO (OUTPUT)	MIN	TYP <sup>(1)</sup>	MAX	UNIT
$f_{max}$	A	B	175			MHz
$t_{PLH}$	A	B	3.1		6.5	ns
$t_{PHL}$			3.1		6.5	
$t_{PLH}$	$\overline{CKOE}$	B	3.6		7.1	ns
$t_{PHL}$			3.6		7.1	
$t_{PLH}$	SYSCLK	B	3.7		7.3	ns
$t_{PHL}$			3.7		7.3	
$t_{en}$	$\overline{OE}$	B	3.3		7	ns
$t_{dis}$			3.3		7	
$t_r$	Rise time, B and SSCLK outputs (20% to 80%)		2.2			ns
$t_f$	Fall time, B and SSCLK outputs (80% to 20%)		1.5			ns
$t_{PLH}$	B	A	2		5.3	ns
$t_{PHL}$			2		5.3	
$t_{PLH}$	$\overline{CKOE}$	A	2.5		5.9	ns
$t_{PHL}$			2.5		5.9	
$t_{PLH}$	SYSCLK	A	2.4		5.9	ns
$t_{PHL}$			2.4		5.9	
$t_{PLH}$	SSCLK	A	2.9		6.7	ns
$t_{PHL}$			2.9		6.7	
$t_{PLH}$	SYSCLK	CLKOUT	3.6		7.5	ns
$t_{PHL}$			3.6		7.5	
$t_{PLH}$	SSCLK	CLKOUT	4		8.5	ns
$t_{PHL}$			4		8.5	
$t_{en}$	$\overline{OE}$	A	2.1		5.8	ns
$t_{dis}$			2.6		6.9	
$t_{en}$	$\overline{CKOE}$	CLKOUT	2.2		5.9	ns
$t_{dis}$			1.8		6	

(1) All typical values are at  $V_{CC} = 3.3\text{ V}$ ,  $T_A = 25^\circ\text{C}$

**SN74GTLPH16927**  
**18-BIT LVTTTL-TO-GTLP BUS TRANSCEIVER**  
**WITH SOURCE-SYNCHRONOUS CLOCK OUTPUTS**

SCES413–OCTOBER 2002–REVISED JUNE 2005

**Skew Characteristics<sup>(1)</sup>**

over recommended ranges of supply voltage and operating free-air temperature,  
 $V_{REF} = 1\text{ V}$  (unless otherwise noted); standard lumped loads,  $C_L = 30\text{ pF}$  for B port (see Figure 1)

PARAMETER	FROM (INPUT)	TO (OUTPUT)	FSTA	TEST CONDITIONS	MIN	MAX	UNIT
$t_{sk(LH)}^{(2)}$	SYSCLK	B			0.5		ns
$t_{sk(HL)}^{(2)}$					0.5		
$t_{sk(LH)}^{(2)}$	SYSCLK	SSCLK → B <sub>n</sub> (see Figure 2)	GND	$V_{CC} = 3.15\text{ V}, T = 85^\circ\text{C}$	3.4	4.7	ns
				$V_{CC} = 3.3\text{ V}, T = 25^\circ\text{C}$	3.2	4.5	
				$V_{CC} = 3.45\text{ V}, T = -40^\circ\text{C}$	3.1	4.4	
$t_{sk(HL)}^{(2)}$	SYSCLK	SSCLK → B <sub>n</sub> (see Figure 2)	GND	$V_{CC} = 3.15\text{ V}, T = 85^\circ\text{C}$	3.2	4.6	ns
				$V_{CC} = 3.3\text{ V}, T = 25^\circ\text{C}$	2.8	4.1	
				$V_{CC} = 3.45\text{ V}, T = -40^\circ\text{C}$	2.4	3.7	
$t_{sk(LH)}^{(2)}$	SYSCLK	SSCLK → B <sub>n</sub> (see Figure 2)	$V_{CC}$	$V_{CC} = 3.15\text{ V}, T = 85^\circ\text{C}$	7.1	8.9	ns
				$V_{CC} = 3.3\text{ V}, T = 25^\circ\text{C}$	6.6	8.4	
				$V_{CC} = 3.45\text{ V}, T = -40^\circ\text{C}$	6.3	8	
$t_{sk(HL)}^{(2)}$	SYSCLK	SSCLK → B <sub>n</sub> (see Figure 2)	$V_{CC}$	$V_{CC} = 3.15\text{ V}, T = 85^\circ\text{C}$	7.2	9	ns
				$V_{CC} = 3.3\text{ V}, T = 25^\circ\text{C}$	6.5	8.2	
				$V_{CC} = 3.45\text{ V}, T = -40^\circ\text{C}$	6	7.6	
$t_{sk(t)}^{(2)}$	SYSCLK	B			1.3		ns
$t_{sk(prLH)}^{(3)}$	SYSCLK	B			1.8		ns
$t_{sk(prHL)}^{(3)}$					2.8		

- (1) Actual skew values between the GTLP outputs could vary on the backplane due to the loading and impedance seen by the device.
- (2)  $t_{sk(LH)}/t_{sk(HL)}$  and  $t_{sk(t)}$  – Output-to-output skew is defined as the absolute value of the difference between the actual propagation delay for all outputs with the same packaged device. The specifications are given for specific worst-case  $V_{CC}$  and temperature. The specifications apply to any outputs switching in the same direction, either high to low [ $t_{sk(HL)}$ ], low to high [ $t_{sk(LH)}$ ], or in opposite directions, both low to high and high to low [ $t_{sk(t)}$ ].
- (3)  $t_{sk(prLH)}$  or  $t_{sk(prHL)}$  – Part-to-part skew is designed as the absolute value of the difference between the actual propagation delay for all outputs from device to device. The parameter is specified for a specific worst-case  $V_{CC}$  and temperature. Furthermore, these values are provided by TI SPICE simulations.

PARAMETER MEASUREMENT INFORMATION

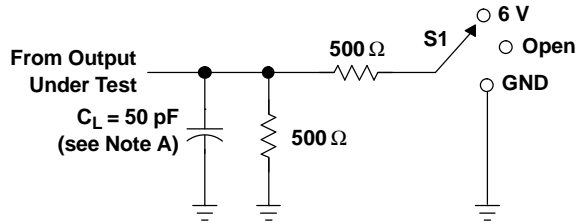

LOAD CIRCUIT FOR A OUTPUTS

TEST	S1
$t_{PLH}/t_{PHL}$	Open
$t_{PLZ}/t_{PZL}$	6 V
$t_{PHZ}/t_{PZH}$	GND

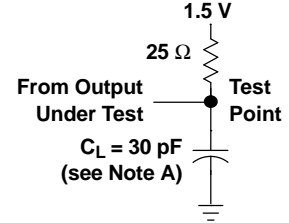

LOAD CIRCUIT FOR B OUTPUTS

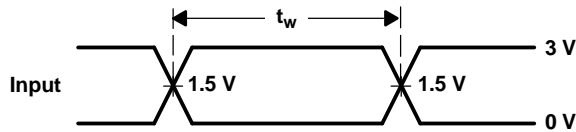

VOLTAGE WAVEFORMS  
PULSE DURATION

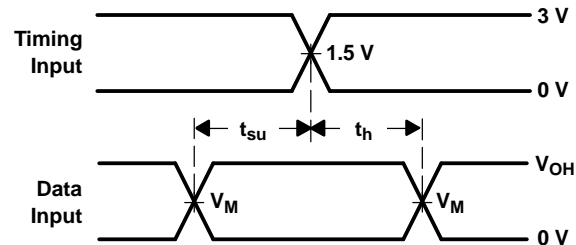

VOLTAGE WAVEFORMS  
SETUP AND HOLD TIMES  
( $V_M = 1.5$  V for A port and 1 V for B port)  
( $V_{OH} = 3$  V for A port and 1.5 V for B port)

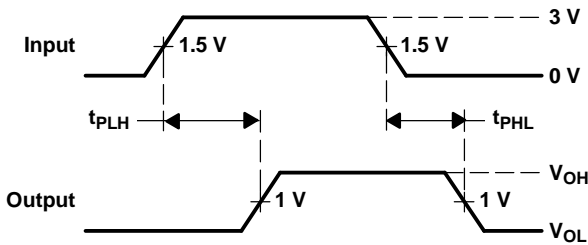

VOLTAGE WAVEFORMS  
PROPAGATION DELAY TIMES  
(A port to B port)

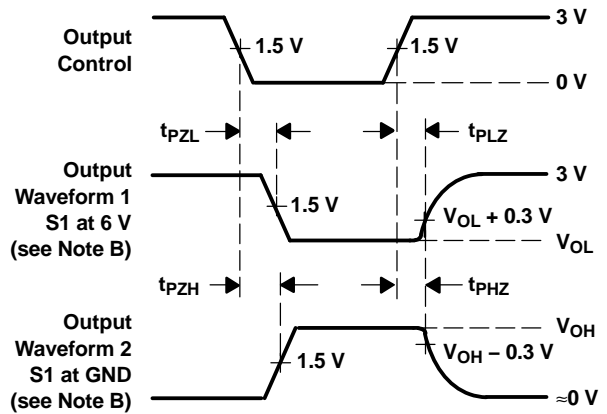

VOLTAGE WAVEFORMS  
ENABLE AND DISABLE TIMES  
(A port)

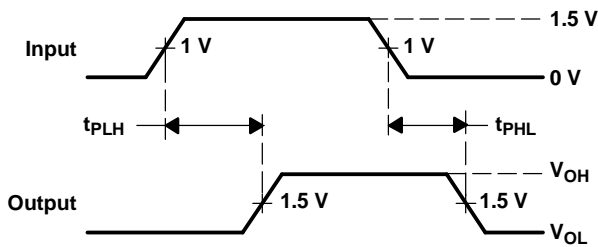

VOLTAGE WAVEFORMS  
PROPAGATION DELAY TIMES  
(B port to A port)

- NOTES: A.  $C_L$  includes probe and jig capacitance.  
 B. Waveform 1 is for an output with internal conditions such that the output is low, except when disabled by the output control. Waveform 2 is for an output with internal conditions such that the output is high, except when disabled by the output control.  
 C. All input pulses are supplied by generators having the following characteristics:  $PRR \leq 10$  MHz,  $Z_O = 50 \Omega$ ,  $t_r \leq 2$  ns,  $t_f \leq 2$  ns.  
 D. The outputs are measured one at a time, with one transition per measurement.  
 E. Load circuit for A outputs also is used for CLKOUT; load circuit for B outputs also is used for SSCLK.

Figure 1. Load Circuits and Voltage Waveforms

PARAMETER MEASUREMENT INFORMATION

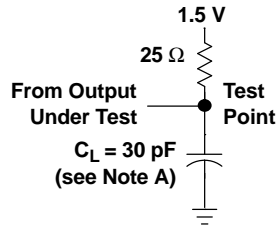

LOAD CIRCUIT FOR B OUTPUTS

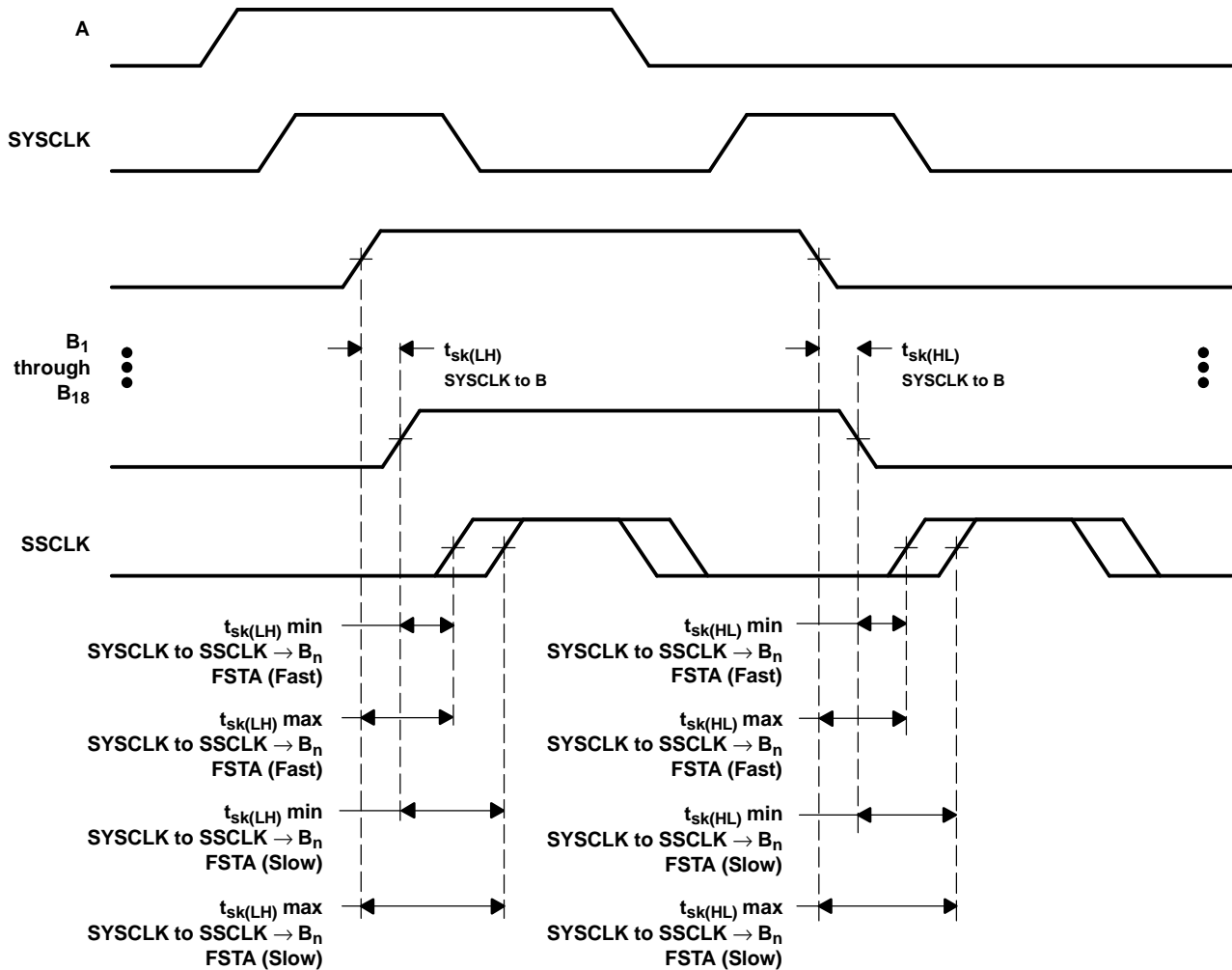

- NOTES: A.  $C_L$  includes probe and jig capacitance.  
 B. All input pulses are supplied by generators having the following characteristics:  $PRR \leq 10$  MHz,  $Z_O = 50 \Omega$ ,  $t_r \leq 2$  ns,  $t_f \leq 2$  ns.  
 C. The outputs are measured one at a time, with one transition per measurement.  
 D. Load circuit for B outputs also is used for SSCLK.

Figure 2. Load Circuit and SYSCLK to SSCLK  $\rightarrow$   $B_n$  Skew Waveforms

### Distributed-Load Backplane Switching Characteristics

The preceding switching characteristics table shows the switching characteristics of the device into a lumped load (Figure 1). However, the designer's backplane application probably is a distributed load. The physical representation is shown in Figure 3. This backplane, or distributed load, can be closely approximated to a resistor inductance capacitance (RLC) circuit, as shown in Figure 4. This device has been designed for optimum performance in this RLC circuit. The following switching characteristics table shows the switching characteristics of the device into the RLC load, to help the designer to better understand the performance of the GTLP device in this typical backplane. See [www.ti.com/sc/gtlp](http://www.ti.com/sc/gtlp) for more information.

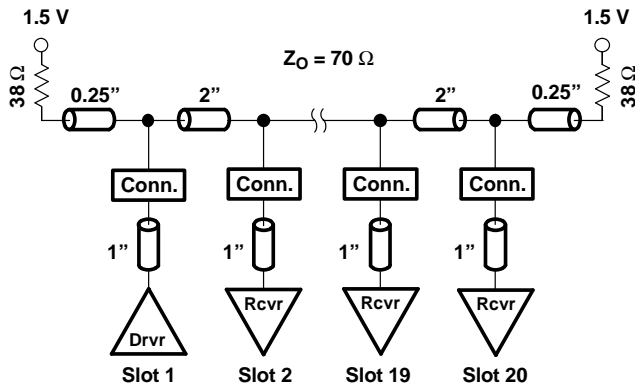

Figure 3. Medium-Drive Test Backplane

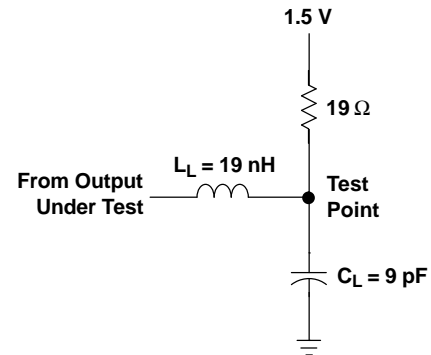

Figure 4. Medium-Drive RLC Network

### Switching Characteristics

over recommended operating conditions for the bus transceiver function (unless otherwise noted) (see Figure 4)

PARAMETER	FROM (INPUT)	TO (OUTPUT)	TYP <sup>(1)</sup>	UNIT
$t_{PLH}$	A	B	4.3	ns
$t_{PHL}$			4.3	
$t_{PLH}$	SYSCLK	B	5	ns
$t_{PHL}$			5	
$t_r$	Rise time, B and SSCLK outputs (20% to 80%)		1.2	ns
$t_f$	Fall time, B and SSCLK outputs (80% to 20%)		1.8	ns

(1) All typical values are at  $V_{CC} = 3.3\text{ V}$ ,  $T_A = 25^\circ\text{C}$ . All values are derived from TI SPICE models.

**PACKAGING INFORMATION**

Orderable Device	Status <sup>(1)</sup>	Package Type	Package Drawing	Pins	Package Qty	Eco Plan <sup>(2)</sup>	Lead/ Ball Finish	MSL Peak Temp <sup>(3)</sup>	Samples (Requires Login)
74GTLPH16927GRE4	ACTIVE	TSSOP	DGG	56	2000	Green (RoHS & no Sb/Br)	CU NIPDAU	Level-1-260C-UNLIM	<a href="#">Request Free Samples</a>
74GTLPH16927GRG4	ACTIVE	TSSOP	DGG	56	2000	Green (RoHS & no Sb/Br)	CU NIPDAU	Level-1-260C-UNLIM	<a href="#">Request Free Samples</a>
74GTLPH16927VRE4	ACTIVE	TVSOP	DGV	56	2000	Green (RoHS & no Sb/Br)	CU NIPDAU	Level-1-260C-UNLIM	<a href="#">Request Free Samples</a>
74GTLPH16927VRG4	ACTIVE	TVSOP	DGV	56	2000	Green (RoHS & no Sb/Br)	CU NIPDAU	Level-1-260C-UNLIM	<a href="#">Request Free Samples</a>
SN74GTLPH16927GR	ACTIVE	TSSOP	DGG	56	2000	Green (RoHS & no Sb/Br)	CU NIPDAU	Level-1-260C-UNLIM	<a href="#">Request Free Samples</a>
SN74GTLPH16927KR	NRND	BGA MICROSTAR JUNIOR	GQL	56	1000	TBD	SNPB	Level-1-240C-UNLIM	Samples Not Available
SN74GTLPH16927VR	ACTIVE	TVSOP	DGV	56	2000	Green (RoHS & no Sb/Br)	CU NIPDAU	Level-1-260C-UNLIM	<a href="#">Request Free Samples</a>
SN74GTLPH16927ZQLR	ACTIVE	BGA MICROSTAR JUNIOR	ZQL	56	1000	Green (RoHS & no Sb/Br)	SNAGCU	Level-1-260C-UNLIM	<a href="#">Purchase Samples</a>

<sup>(1)</sup> The marketing status values are defined as follows:

**ACTIVE:** Product device recommended for new designs.

**LIFEBUY:** TI has announced that the device will be discontinued, and a lifetime-buy period is in effect.

**NRND:** Not recommended for new designs. Device is in production to support existing customers, but TI does not recommend using this part in a new design.

**PREVIEW:** Device has been announced but is not in production. Samples may or may not be available.

**OBsolete:** TI has discontinued the production of the device.

<sup>(2)</sup> Eco Plan - The planned eco-friendly classification: Pb-Free (RoHS), Pb-Free (RoHS Exempt), or Green (RoHS & no Sb/Br) - please check <http://www.ti.com/productcontent> for the latest availability information and additional product content details.

**TBD:** The Pb-Free/Green conversion plan has not been defined.

**Pb-Free (RoHS):** TI's terms "Lead-Free" or "Pb-Free" mean semiconductor products that are compatible with the current RoHS requirements for all 6 substances, including the requirement that lead not exceed 0.1% by weight in homogeneous materials. Where designed to be soldered at high temperatures, TI Pb-Free products are suitable for use in specified lead-free processes.

**Pb-Free (RoHS Exempt):** This component has a RoHS exemption for either 1) lead-based flip-chip solder bumps used between the die and package, or 2) lead-based die adhesive used between the die and leadframe. The component is otherwise considered Pb-Free (RoHS compatible) as defined above.

**Green (RoHS & no Sb/Br):** TI defines "Green" to mean Pb-Free (RoHS compatible), and free of Bromine (Br) and Antimony (Sb) based flame retardants (Br or Sb do not exceed 0.1% by weight in homogeneous material)

<sup>(3)</sup> MSL, Peak Temp. -- The Moisture Sensitivity Level rating according to the JEDEC industry standard classifications, and peak solder temperature.

**Important Information and Disclaimer:** The information provided on this page represents TI's knowledge and belief as of the date that it is provided. TI bases its knowledge and belief on information provided by third parties, and makes no representation or warranty as to the accuracy of such information. Efforts are underway to better integrate information from third parties. TI has taken and continues to take reasonable steps to provide representative and accurate information but may not have conducted destructive testing or chemical analysis on incoming materials and chemicals. TI and TI suppliers consider certain information to be proprietary, and thus CAS numbers and other limited information may not be available for release.

In no event shall TI's liability arising out of such information exceed the total purchase price of the TI part(s) at issue in this document sold by TI to Customer on an annual basis.

**TAPE AND REEL INFORMATION**



**QUADRANT ASSIGNMENTS FOR PIN 1 ORIENTATION IN TAPE**



\*All dimensions are nominal

Device	Package Type	Package Drawing	Pins	SPQ	Reel Diameter (mm)	Reel Width W1 (mm)	A0 (mm)	B0 (mm)	K0 (mm)	P1 (mm)	W (mm)	Pin1 Quadrant
SN74GTLPH16927GR	TSSOP	DGG	56	2000	330.0	24.4	8.6	15.6	1.8	12.0	24.0	Q1
SN74GTLPH16927KR	BGA MICROSTAR JUNIOR	GQL	56	1000	330.0	16.4	4.8	7.3	1.45	8.0	16.0	Q1
SN74GTLPH16927VR	TVSOP	DGV	56	2000	330.0	24.4	6.8	11.7	1.6	12.0	24.0	Q1
SN74GTLPH16927ZQLR	BGA MICROSTAR JUNIOR	ZQL	56	1000	330.0	16.4	4.8	7.3	1.45	8.0	16.0	Q1

**TAPE AND REEL BOX DIMENSIONS**

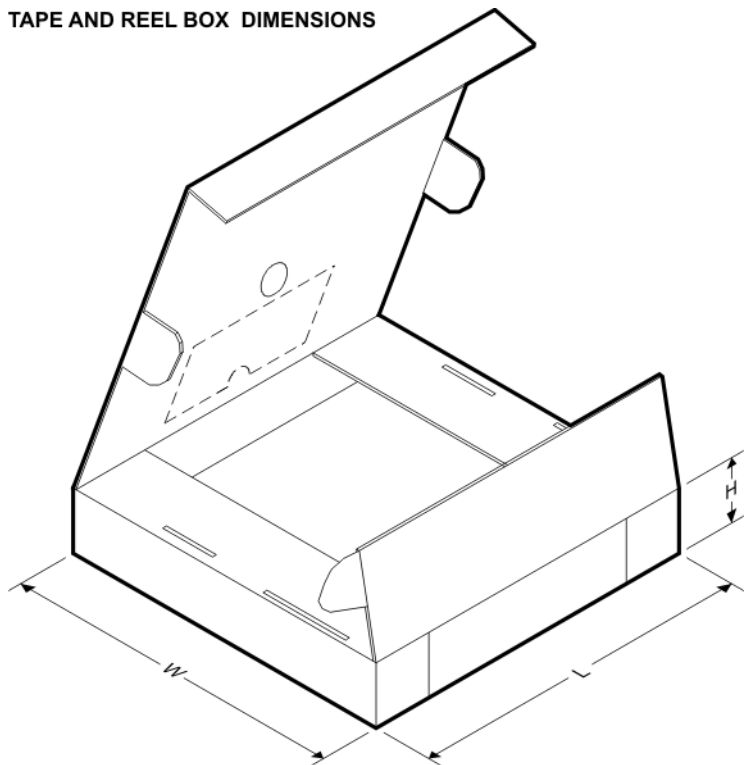

\*All dimensions are nominal

Device	Package Type	Package Drawing	Pins	SPQ	Length (mm)	Width (mm)	Height (mm)
SN74GTLPH16927GR	TSSOP	DGG	56	2000	346.0	346.0	41.0
SN74GTLPH16927KR	BGA MICROSTAR JUNIOR	GQL	56	1000	346.0	346.0	33.0
SN74GTLPH16927VR	TVSOP	DGV	56	2000	346.0	346.0	41.0
SN74GTLPH16927ZQLR	BGA MICROSTAR JUNIOR	ZQL	56	1000	346.0	346.0	33.0

ZQL (R-PBGA-N56)

PLASTIC BALL GRID ARRAY

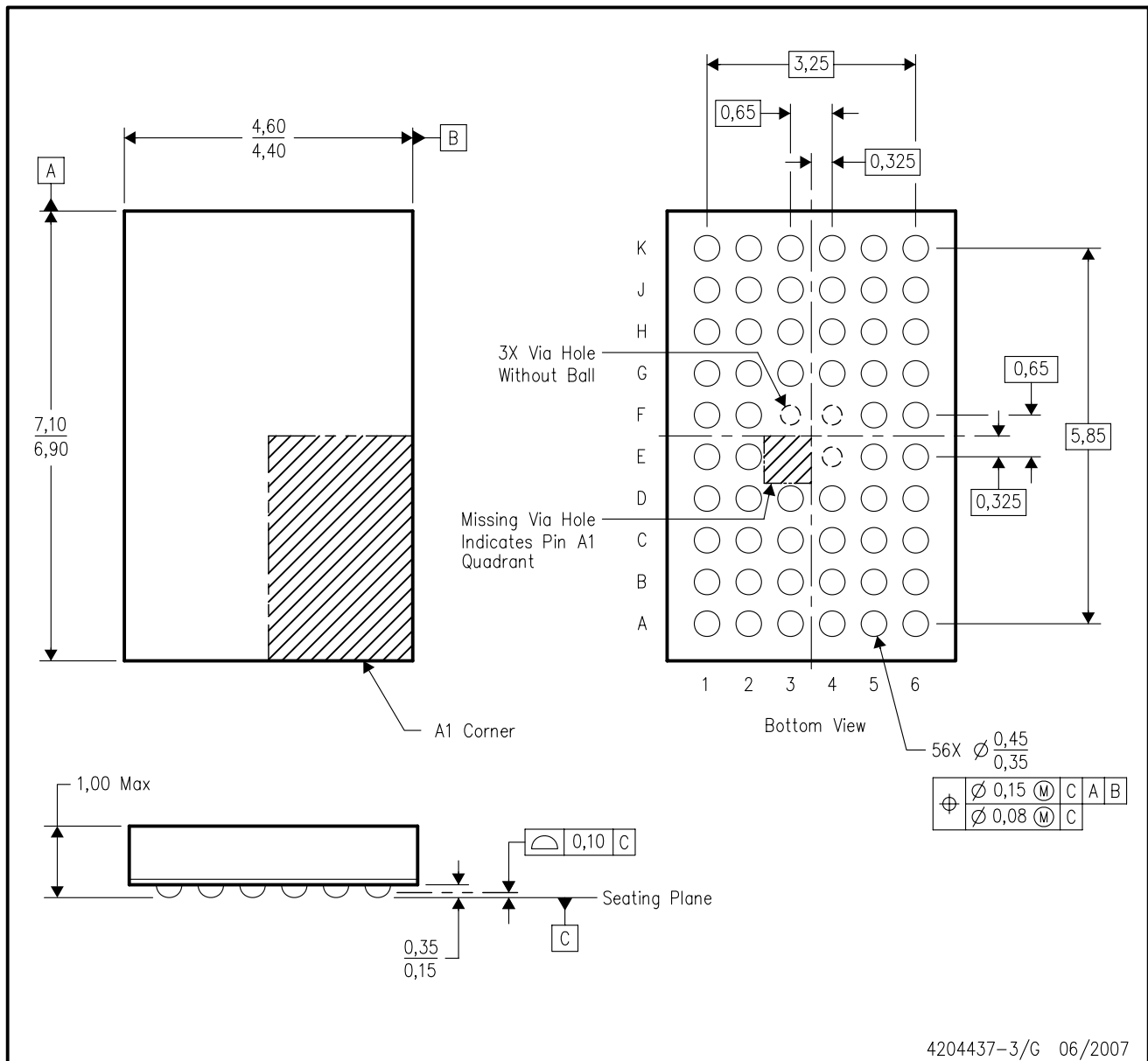

- NOTES:
- A. All linear dimensions are in millimeters. Dimensioning and tolerancing per ASME Y14.5M-1994.
  - B. This drawing is subject to change without notice.
  - C. Falls within JEDEC MO-285 variation BA-2.
  - D. This package is lead-free. Refer to the 56 GQL package (drawing 4200583) for tin-lead (SnPb).

DGV (R-PDSO-G\*\*)

PLASTIC SMALL-OUTLINE

24 PINS SHOWN



4073251/E 08/00

- NOTES: A. All linear dimensions are in millimeters.  
 B. This drawing is subject to change without notice.  
 C. Body dimensions do not include mold flash or protrusion, not to exceed 0,15 per side.  
 D. Falls within JEDEC: 24/48 Pins – MO-153  
 14/16/20/56 Pins – MO-194

GQL (R-PBGA-N56)

PLASTIC BALL GRID ARRAY

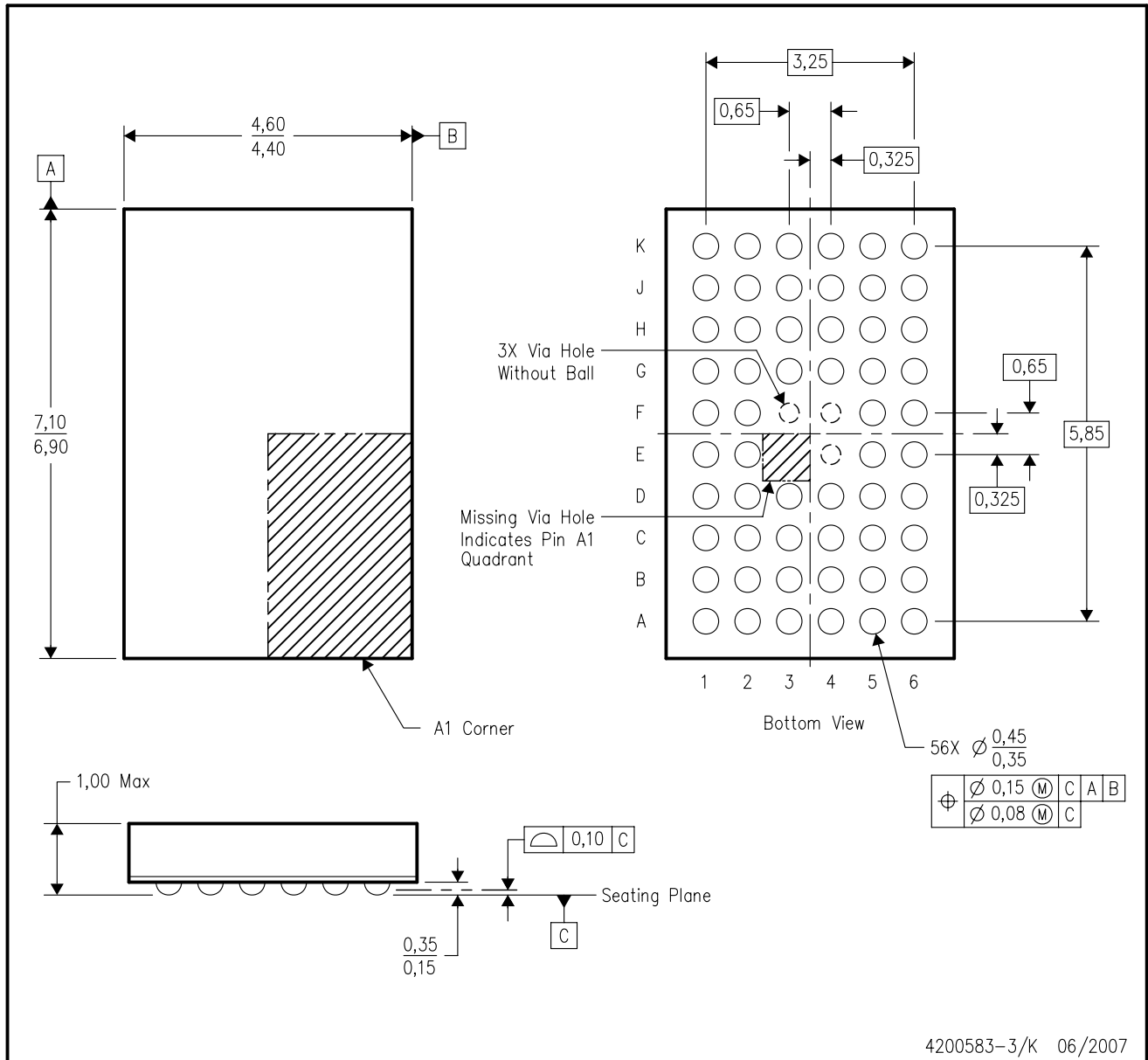

4200583-3/K 06/2007

- NOTES:
- A. All linear dimensions are in millimeters. Dimensioning and tolerancing per ASME Y14.5M-1994.
  - B. This drawing is subject to change without notice.
  - C. Falls within JEDEC MO-285 variation BA-2.
  - D. This package is tin-lead (SnPb). Refer to the 56 ZQL package (drawing 4204437) for lead-free.

DGG (R-PDSO-G\*\*)

PLASTIC SMALL-OUTLINE PACKAGE

48 PINS SHOWN

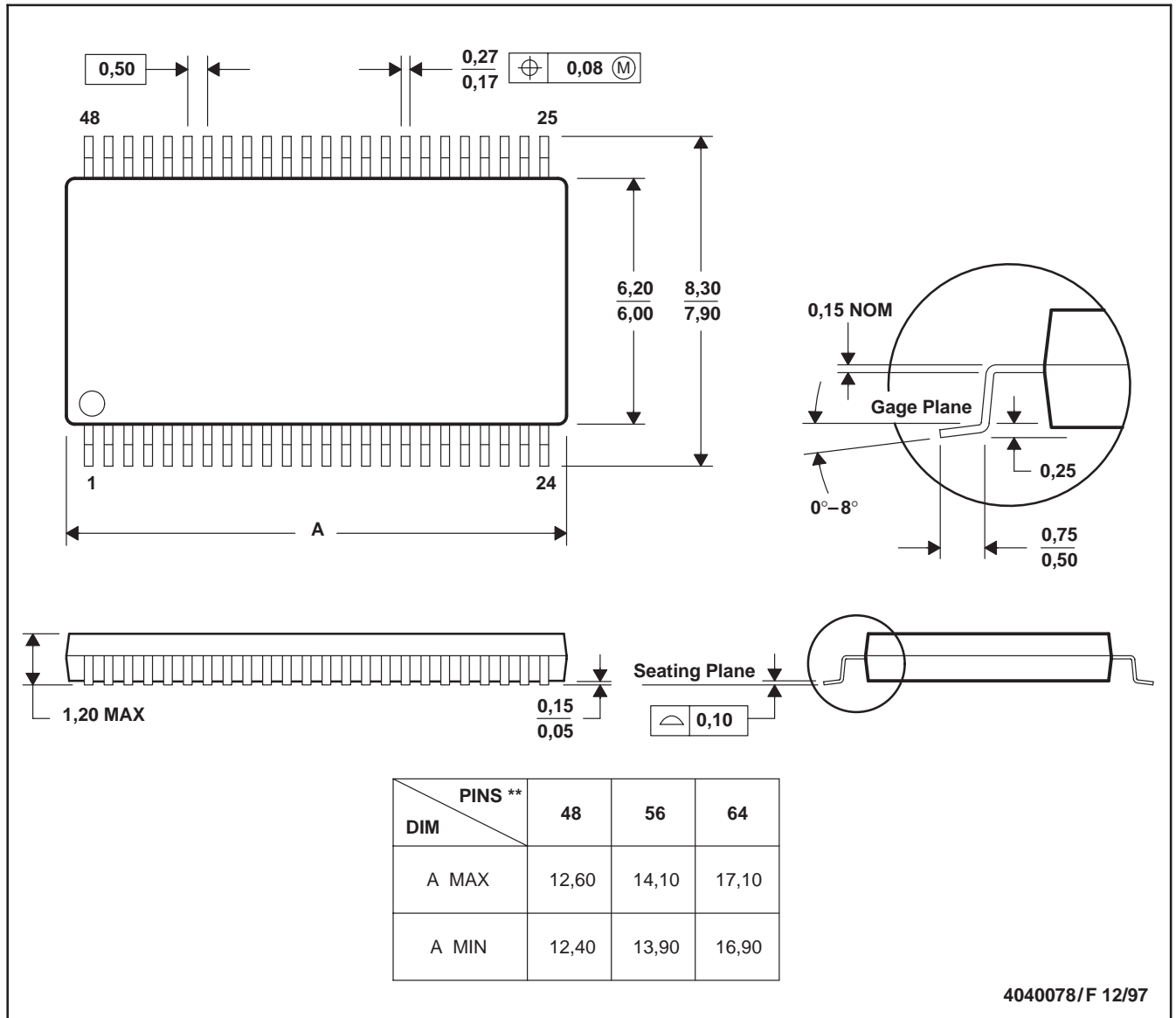

- NOTES: A. All linear dimensions are in millimeters.  
 B. This drawing is subject to change without notice.  
 C. Body dimensions do not include mold protrusion not to exceed 0,15.  
 D. Falls within JEDEC MO-153

## IMPORTANT NOTICE

Texas Instruments Incorporated and its subsidiaries (TI) reserve the right to make corrections, modifications, enhancements, improvements, and other changes to its products and services at any time and to discontinue any product or service without notice. Customers should obtain the latest relevant information before placing orders and should verify that such information is current and complete. All products are sold subject to TI's terms and conditions of sale supplied at the time of order acknowledgment.

TI warrants performance of its hardware products to the specifications applicable at the time of sale in accordance with TI's standard warranty. Testing and other quality control techniques are used to the extent TI deems necessary to support this warranty. Except where mandated by government requirements, testing of all parameters of each product is not necessarily performed.

TI assumes no liability for applications assistance or customer product design. Customers are responsible for their products and applications using TI components. To minimize the risks associated with customer products and applications, customers should provide adequate design and operating safeguards.

TI does not warrant or represent that any license, either express or implied, is granted under any TI patent right, copyright, mask work right, or other TI intellectual property right relating to any combination, machine, or process in which TI products or services are used. Information published by TI regarding third-party products or services does not constitute a license from TI to use such products or services or a warranty or endorsement thereof. Use of such information may require a license from a third party under the patents or other intellectual property of the third party, or a license from TI under the patents or other intellectual property of TI.

Reproduction of TI information in TI data books or data sheets is permissible only if reproduction is without alteration and is accompanied by all associated warranties, conditions, limitations, and notices. Reproduction of this information with alteration is an unfair and deceptive business practice. TI is not responsible or liable for such altered documentation. Information of third parties may be subject to additional restrictions.

Resale of TI products or services with statements different from or beyond the parameters stated by TI for that product or service voids all express and any implied warranties for the associated TI product or service and is an unfair and deceptive business practice. TI is not responsible or liable for any such statements.

TI products are not authorized for use in safety-critical applications (such as life support) where a failure of the TI product would reasonably be expected to cause severe personal injury or death, unless officers of the parties have executed an agreement specifically governing such use. Buyers represent that they have all necessary expertise in the safety and regulatory ramifications of their applications, and acknowledge and agree that they are solely responsible for all legal, regulatory and safety-related requirements concerning their products and any use of TI products in such safety-critical applications, notwithstanding any applications-related information or support that may be provided by TI. Further, Buyers must fully indemnify TI and its representatives against any damages arising out of the use of TI products in such safety-critical applications.

TI products are neither designed nor intended for use in military/aerospace applications or environments unless the TI products are specifically designated by TI as military-grade or "enhanced plastic." Only products designated by TI as military-grade meet military specifications. Buyers acknowledge and agree that any such use of TI products which TI has not designated as military-grade is solely at the Buyer's risk, and that they are solely responsible for compliance with all legal and regulatory requirements in connection with such use.

TI products are neither designed nor intended for use in automotive applications or environments unless the specific TI products are designated by TI as compliant with ISO/TS 16949 requirements. Buyers acknowledge and agree that, if they use any non-designated products in automotive applications, TI will not be responsible for any failure to meet such requirements.

Following are URLs where you can obtain information on other Texas Instruments products and application solutions:

<b>Products</b>		<b>Applications</b>	
Amplifiers	<a href="http://amplifier.ti.com">amplifier.ti.com</a>	Audio	<a href="http://www.ti.com/audio">www.ti.com/audio</a>
Data Converters	<a href="http://dataconverter.ti.com">dataconverter.ti.com</a>	Automotive	<a href="http://www.ti.com/automotive">www.ti.com/automotive</a>
DLP® Products	<a href="http://www.dlp.com">www.dlp.com</a>	Communications and Telecom	<a href="http://www.ti.com/communications">www.ti.com/communications</a>
DSP	<a href="http://dsp.ti.com">dsp.ti.com</a>	Computers and Peripherals	<a href="http://www.ti.com/computers">www.ti.com/computers</a>
Clocks and Timers	<a href="http://www.ti.com/clocks">www.ti.com/clocks</a>	Consumer Electronics	<a href="http://www.ti.com/consumer-apps">www.ti.com/consumer-apps</a>
Interface	<a href="http://interface.ti.com">interface.ti.com</a>	Energy	<a href="http://www.ti.com/energy">www.ti.com/energy</a>
Logic	<a href="http://logic.ti.com">logic.ti.com</a>	Industrial	<a href="http://www.ti.com/industrial">www.ti.com/industrial</a>
Power Mgmt	<a href="http://power.ti.com">power.ti.com</a>	Medical	<a href="http://www.ti.com/medical">www.ti.com/medical</a>
Microcontrollers	<a href="http://microcontroller.ti.com">microcontroller.ti.com</a>	Security	<a href="http://www.ti.com/security">www.ti.com/security</a>
RFID	<a href="http://www.ti-rfid.com">www.ti-rfid.com</a>	Space, Avionics & Defense	<a href="http://www.ti.com/space-avionics-defense">www.ti.com/space-avionics-defense</a>
RF/IF and ZigBee® Solutions	<a href="http://www.ti.com/lprf">www.ti.com/lprf</a>	Video and Imaging	<a href="http://www.ti.com/video">www.ti.com/video</a>
		Wireless	<a href="http://www.ti.com/wireless-apps">www.ti.com/wireless-apps</a>

Mailing Address: Texas Instruments, Post Office Box 655303, Dallas, Texas 75265  
Copyright © 2010, Texas Instruments Incorporated

## Looking for pricing, stock, or lifecycle information?

Click below to explore more details on WIN SOURCE:

 [View SN74GTLPH16927VR on WIN SOURCE](#)

 [Texas Instruments](#) Information

## Optimize Your Supply Chain with WIN SOURCE Solutions

-  Global Sourcing Solution
-  Obsolete Management
-  Cost Control Management
-  Shortage Management
-  Alternative Solution
-  Excess Inventory Management