



THE DATASHEET OF TDE1767ADP



Interface circuit (relay and lamp driver)

Datasheet - production data

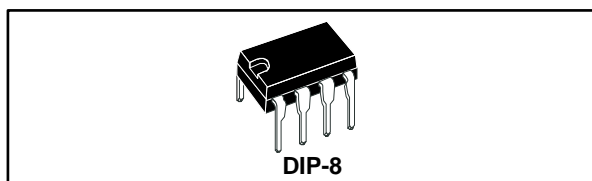

Features

- Open ground protection
- High output current
- Adjustable short-circuit protection
- Internal thermal protection with external reset
- Large supply voltage range
- Alarm output
- Input voltage can be higher than V_{CC}
- Output voltage can be lower than ground ($V_{CC} - V_O \leq V_{CC(max.)}$)

Description

This device is a monolithic amplifier designed for high current and high voltage applications,

specifically to drive lamps, relays, stepping motors. It is a blow-out proof device whose output is protected against overload and short-circuits. This output is low in open ground conditions and in case of overload and reset for high input, it switches on and off alternately until the overload is removed. The LED, driven by an alarm output, if referred to ground, flashes during an overload depending on the state of the reset input. The thermal shutdown prevents the IC from overheating, so if the internal dissipation becomes too high, the driver shuts down. The device works over a wide range of voltages from standard 15 V operational amplifier to the single +6 V or +48 V used for industrial electric systems.

Table 1: Device summary

Order code	Package	Packing
TDE1787ADP	DIP-8	Tube

Contents

1	Pin connections.....	5
2	Maximum ratings.....	6
3	Electrical characteristics	7
4	Schematic diagram.....	8
5	Typical characteristics.....	9
6	Typical application	11
7	Using alarm output.....	13
8	Package information	15
	8.1 DIP-8 package information.....	15
9	Revision history	17

List of tables

Table 1: Device summary	1
Table 2: Pin description	5
Table 3: Absolute maximum ratings	6
Table 4: Thermal data.....	6
Table 5: Electrical characteristics	7
Table 6: DIP-8 package mechanical data.....	16
Table 7: Document revision history	17

List of figures

Figure 1: Pin connections (top view).....	5
Figure 2: Schematic diagram.....	8
Figure 3: Equivalent diagram.....	8
Figure 4: Peak short-circuit vs. limiting resistor.....	9
Figure 5: Available output current vs. limiting resistor.....	9
Figure 6: Power supply current (pin 4).....	9
Figure 7: Output saturation voltage vs. output current.....	9
Figure 8: Output transistor safe operating area (pulsed).....	9
Figure 9: Normal operating area (short-circuit protected).....	9
Figure 10: Current sinking.....	10
Figure 11: Current sourcing.....	10
Figure 12: Response time.....	10
Figure 13: Response time (2.5 V).....	10
Figure 14: Test circuit.....	11
Figure 15: Open load detection 4.....	11
Figure 16: Driving lamps, relays.....	11
Figure 17: Common reset.....	12
Figure 18: Parallel driving of loads up to 1 A.....	12
Figure 19: Parallel output alarm.....	13
Figure 20: LED to V_{CC}	13
Figure 21: LED to ground.....	13
Figure 22: Interface between high voltage and low voltage system.....	13
Figure 23: Increasing current up to 10 A.....	14
Figure 24: DIP-8 package outline.....	15

1 Pin connections

Figure 1: Pin connections (top view)

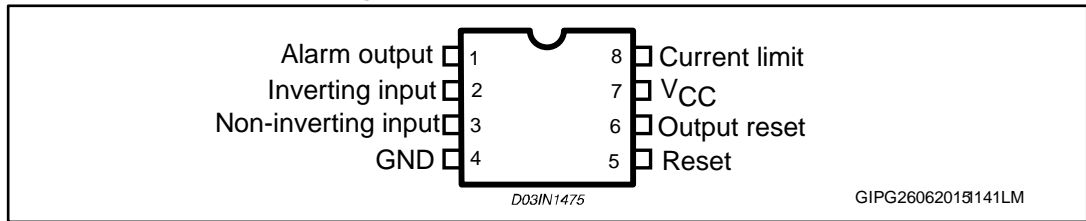

Table 2: Pin description

Pin	Function
1	Alarm output
2	Inverting input
3	Non-inverting input
4	GND
5	Reset
6	Output reset
7	Vcc
8	Current limit

2 Maximum ratings

Table 3: Absolute maximum ratings

Symbol	Parameter	Value	Unit
V_{CC}	Supply voltage	60	V
V_{ID}	Input differential voltage	60	V
V_I	Input voltage	-10 to +60	V
I_O	Output current	1.3	A
$V_{I(\text{reset})}$	Reset input voltage	-0.5 to +60	V
I_{OA}	Alarm output current	-10 to 20	mA
P_{tot}	Power dissipation	Internally limited	mW
T_{oper}	Operating ambient temperature range	-25 to +85	°C
T_{stg}	Storage temperature range	-65 to +150	°C

Table 4: Thermal data

Symbol	Parameter	Value	Unit
$R_{\text{th}(JC)}$	Thermal resistance junction-case	30 max.	°C/W
$R_{\text{th}(JA)}$	Thermal resistance junction-ambient	80 max.	°C/W



The device is bonded on a 40 cm² glass-epoxy printed circuit, 0.15 cm thick with 4 cm² of copper.

3 Electrical characteristics

$-25\text{ }^{\circ}\text{C} \leq T_A \leq 85\text{ }^{\circ}\text{C}$, $6\text{ V} \leq V_{CC} \leq 55\text{ V}$, $T_J \leq 150\text{ }^{\circ}\text{C}$, $I_O \leq 300\text{ mA}$ for $R_{SC} = 330\text{ m}\Omega$ and $I_O \leq 500\text{ mA}$ for $R_{SC} = 220\text{ m}\Omega$, unless otherwise specified.

Table 5: Electrical characteristics

Symbol	Parameter	Test conditions	Min.	Typ.	Max.	Unit
V_{IO}	Input offset voltage	See note ⁽¹⁾		2	50	mV
I_{CC}	Power supply current	Measured on pin 4 Output high ($T_A = 25\text{ }^{\circ}\text{C}$)		5.8	8	mA
		Output high $V_{CC} = V_{CCmax}$, ($T_J = 150\text{ }^{\circ}\text{C}$)		5	7	mA
		Output low $V_{CC} = V_{CCmax}$, ($T_A = 25\text{ }^{\circ}\text{C}$)		1.5	4	mA
I_{IB}	Input bias current			15	100	μA
V_{CM}	Common mode input voltage range		1		60	V
V_I	Input voltage range	$V_{ref} \geq 1\text{ V}$, see note ⁽²⁾ and Figure 1: "Pin connections (top view)"	1		60	V
I_{SC}	Short-circuit output current	$V_{CC} = 35\text{ V}$, $t = 10\text{ ms}$ $R_{SC} = 0.22\text{ }\Omega$		700		mA
		$R_{SC} = 0.33\text{ }\Omega$		380		
V_{sense}	Output limit sense voltage	$V_O = V_{CC} - 2\text{ V}$, $t = 10\text{ ms}$	130	150	170	mV
		$V_O = 0\text{ V}$, $t = 10\text{ ms}$	120	140	165	
$V_{O(sat)}$	Output saturation voltage	Output high $V_I^+ - V_I^- \geq 50\text{ mV}$; $R_{SC} = 0$; $V_{CC} = 30\text{ V}$ $T_J = 25\text{ }^{\circ}\text{C}$		1	1.1	V
		$T_J = 150\text{ }^{\circ}\text{C}$		1.1	1.2	V
I_{OL}	Output leakage current	Output low			100	μA
I_A	Available alarm output current	Output source current $V_{AH} = V_{CC} - 2.5\text{ V}$	-4	-5		mA
		Output sink current in thermal shutdown $V_A = 1.4\text{ V}$	5	10		mA
I_{reset}	Reset input current			2	40	μA
V_{th_reset}	Reset threshold			1.4		V
I_{LGND}	Output leakage current	Open ground		10		μA

Notes:

⁽¹⁾The offset voltage given is the maximum value of different input voltage required to drive the output voltage within 2 V of ground or the supply voltage.

⁽²⁾Input voltage range is independent of the supply voltage.

4 Schematic diagram

Figure 2: Schematic diagram

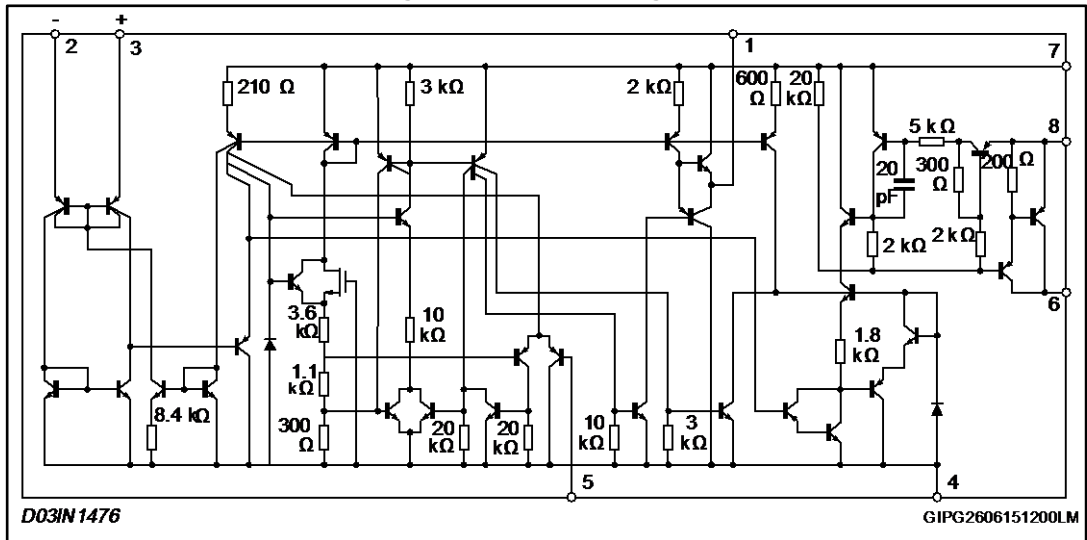
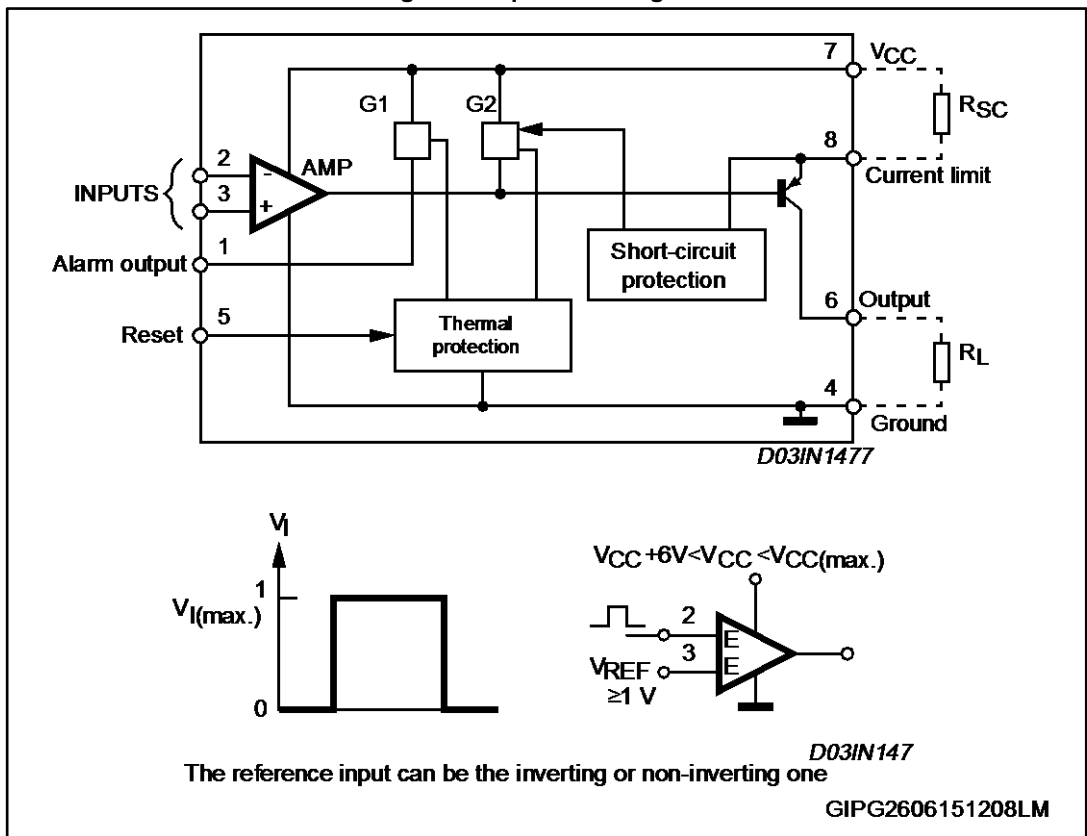

Figure 3: Equivalent diagram



5 Typical characteristics

Figure 4: Peak short-circuit vs. limiting resistor

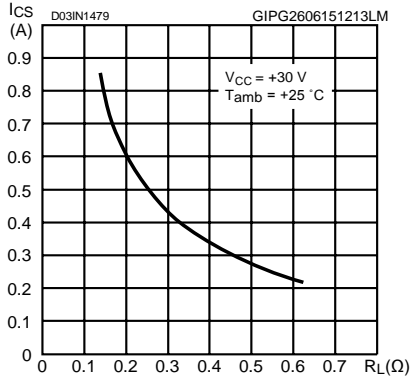

Figure 5: Available output current vs. limiting resistor

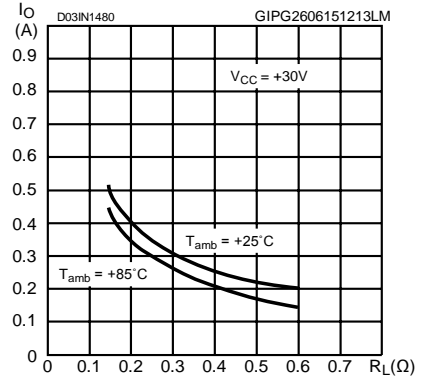

Figure 6: Power supply current (pin 4)

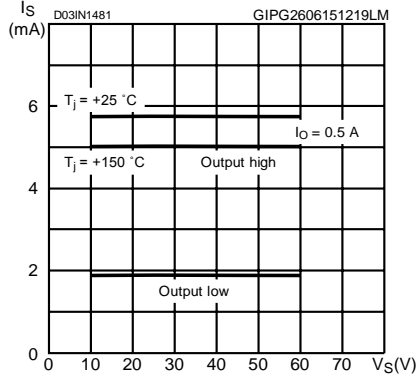

Figure 7: Output saturation voltage vs. output current

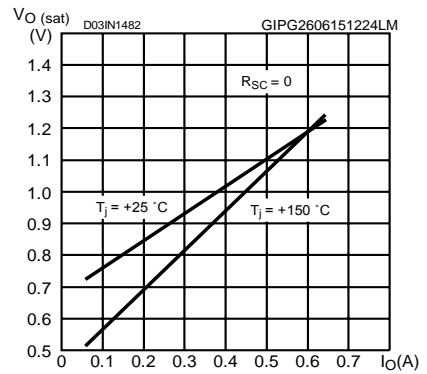

Figure 8: Output transistor safe operating area (pulsed)

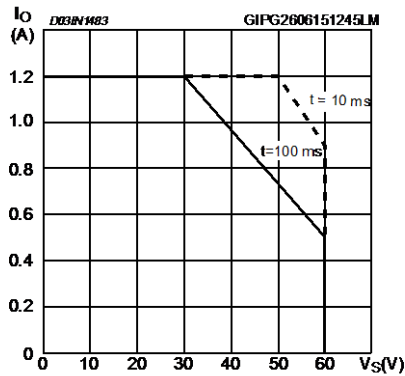

Figure 9: Normal operating area (short-circuit protected)

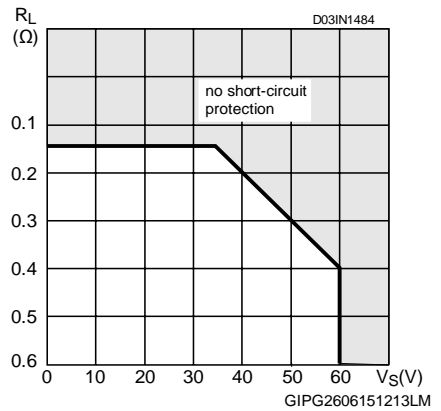

Figure 10: Current sinking

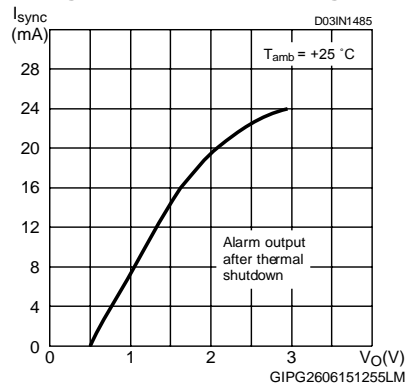

Figure 11: Current sourcing

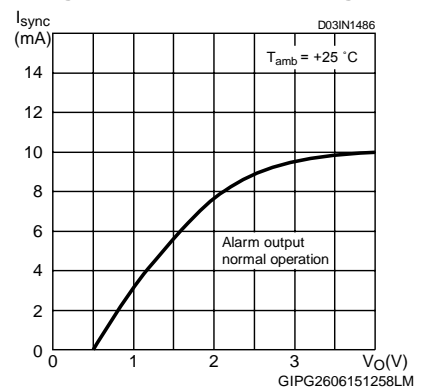

Figure 12: Response time

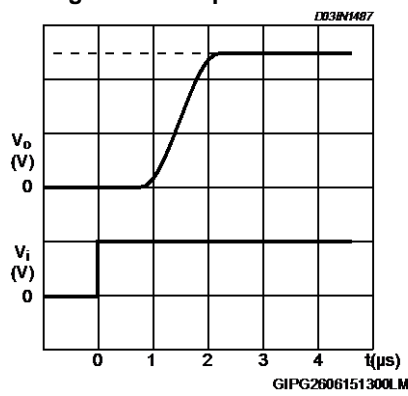
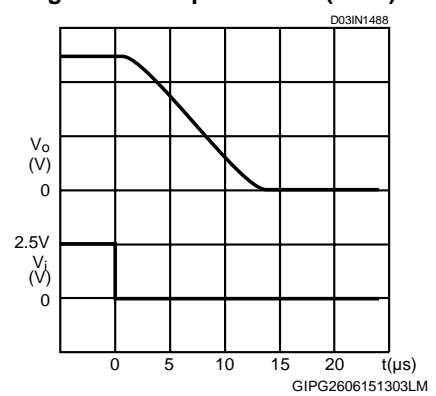

Figure 13: Response time (2.5 V)



6 Typical application

Figure 14: Test circuit

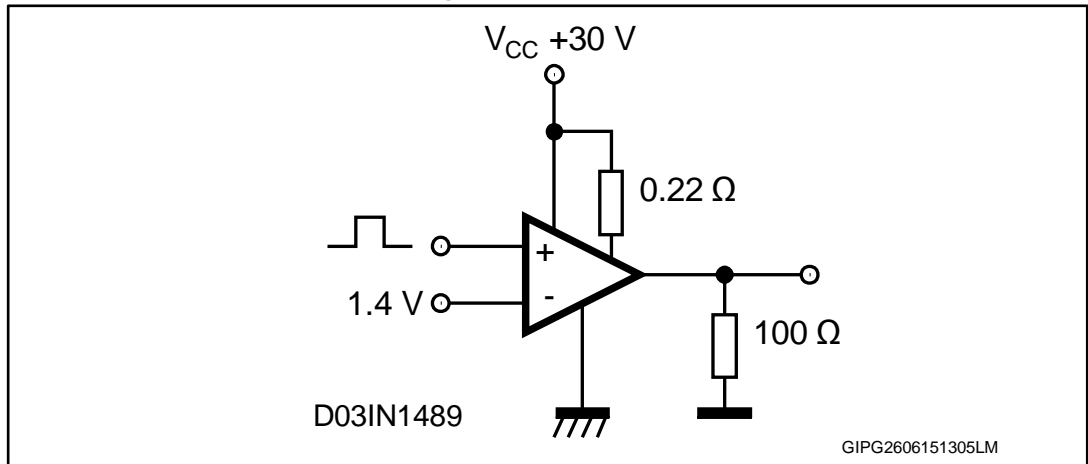

Figure 15: Open load detection 4

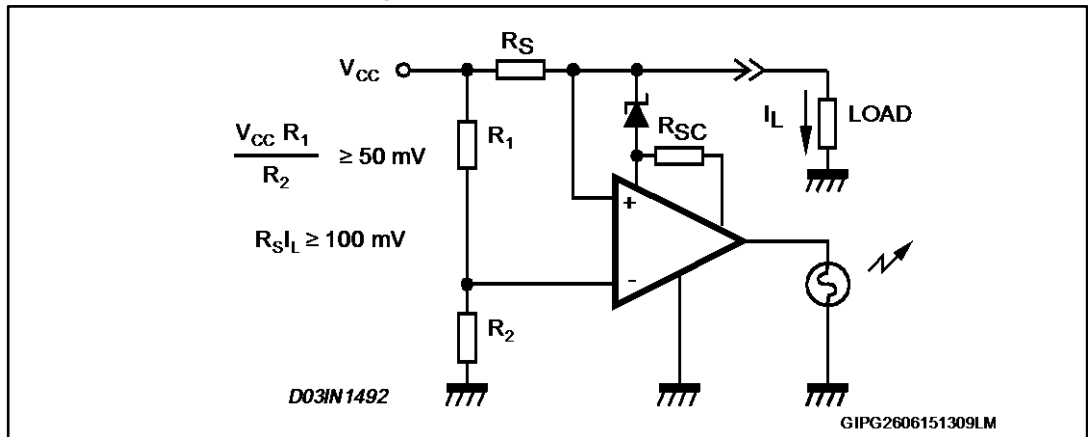

Figure 16: Driving lamps, relays

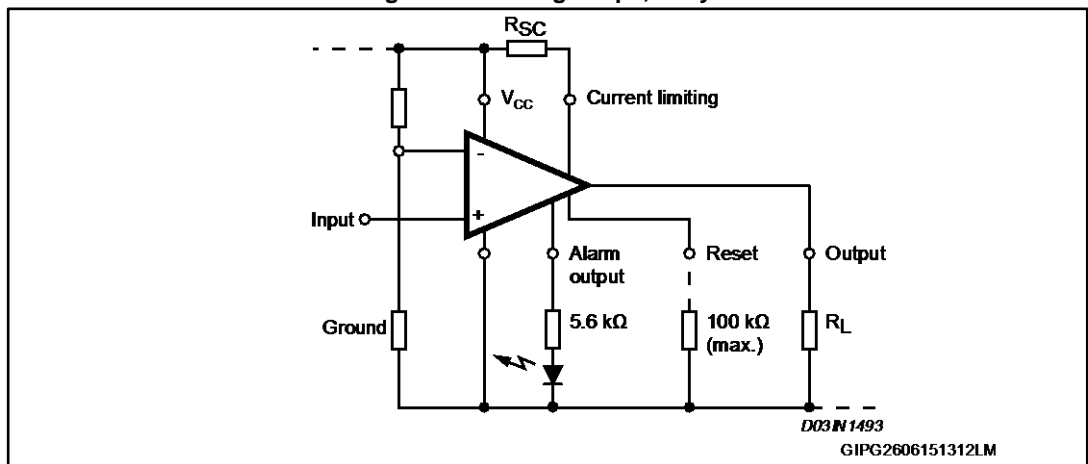

Figure 17: Common reset

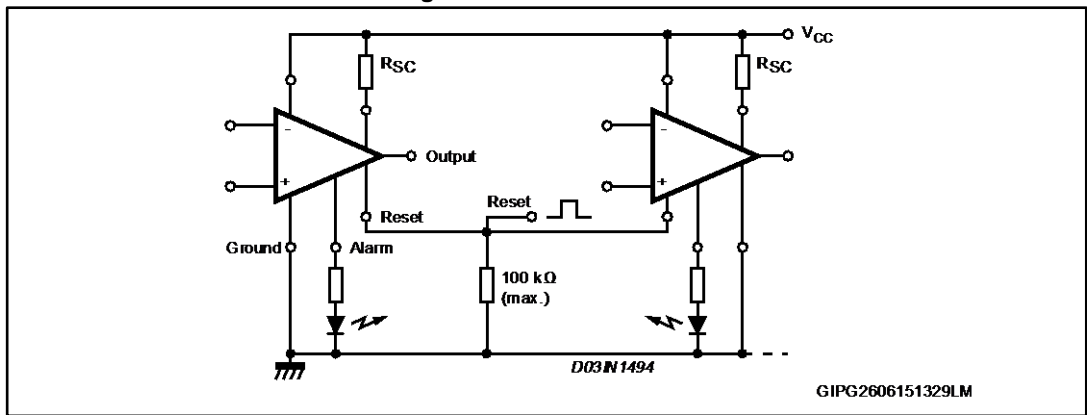
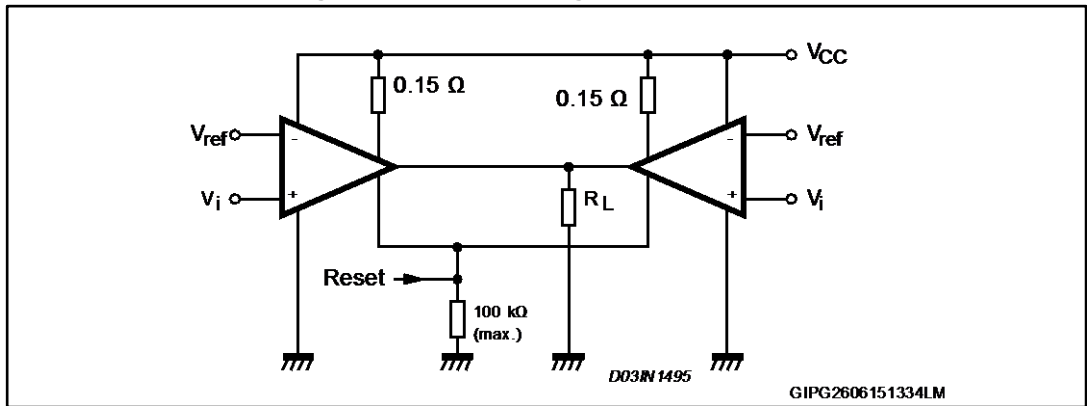

Figure 18: Parallel driving of loads up to 1 A



7 Using alarm output

Figure 19: Parallel output alarm

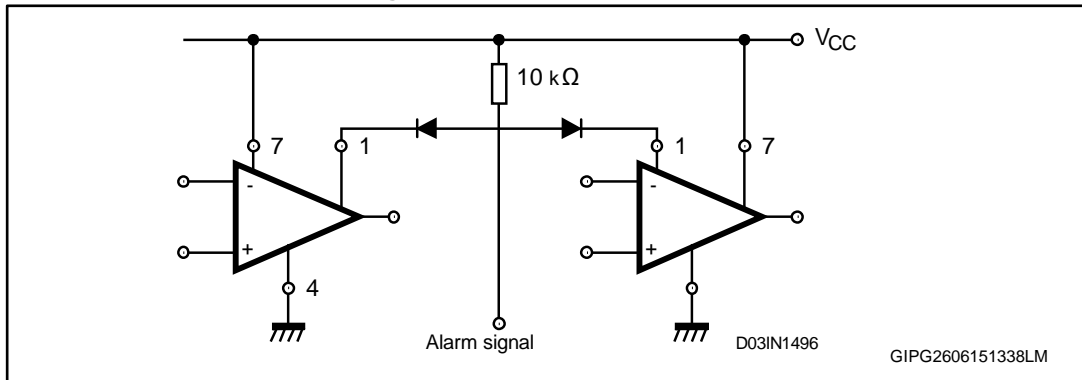

Figure 20: LED to VCC

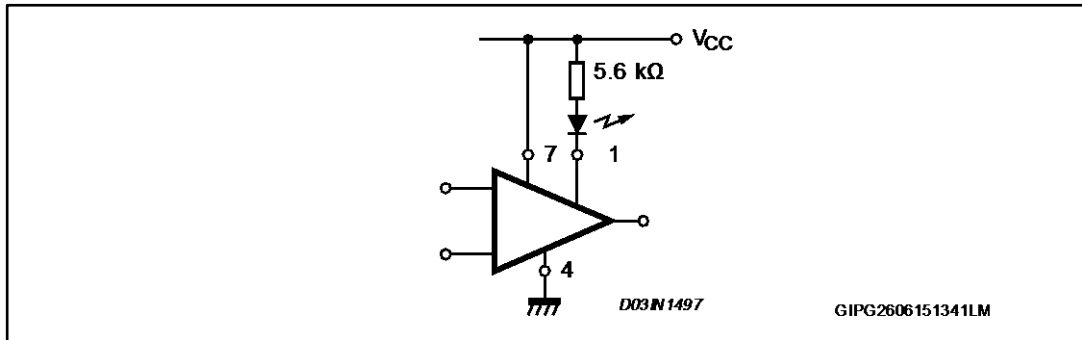

Figure 21: LED to ground

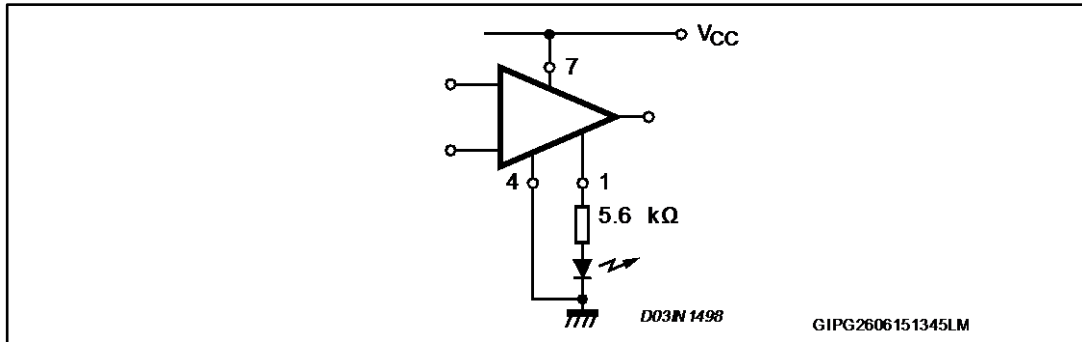

Figure 22: Interface between high voltage and low voltage system

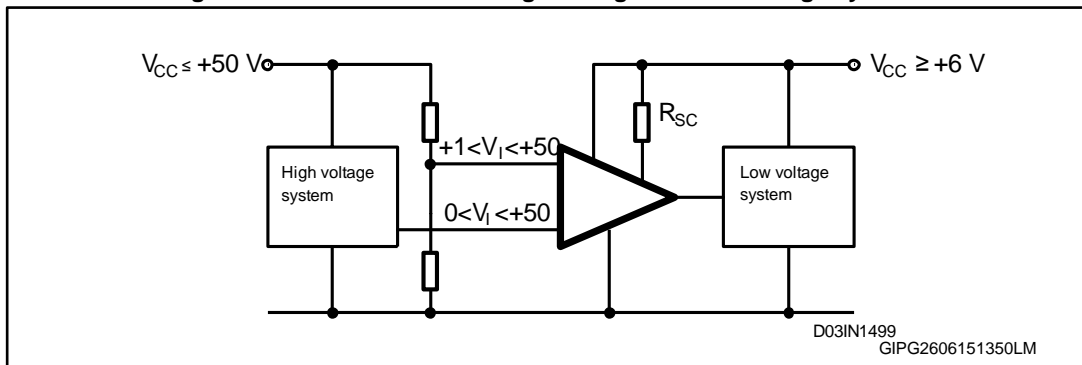
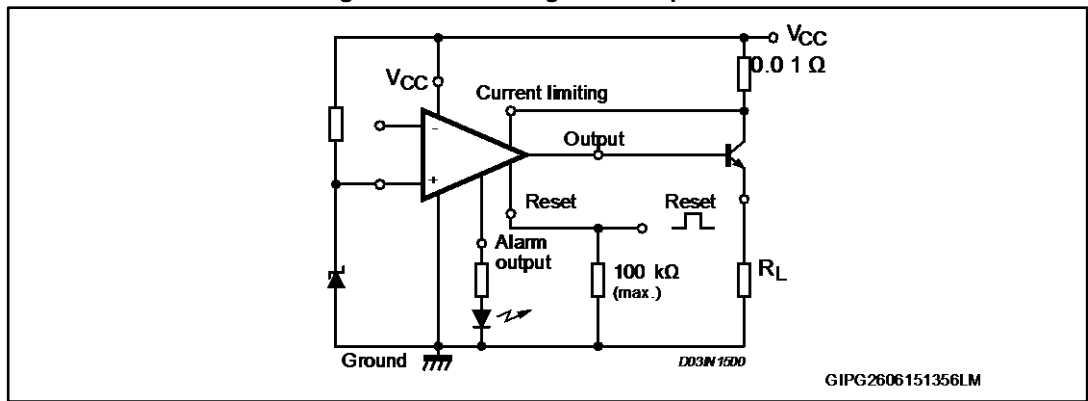

Figure 23: Increasing current up to 10 A



8 Package information

In order to meet environmental requirements, ST offers these devices in different grades of ECOPACK[®] packages, depending on their level of environmental compliance. ECOPACK[®] specifications, grade definitions and product status are available at: www.st.com. ECOPACK[®] is an ST trademark.

8.1 DIP-8 package information

Figure 24: DIP-8 package outline

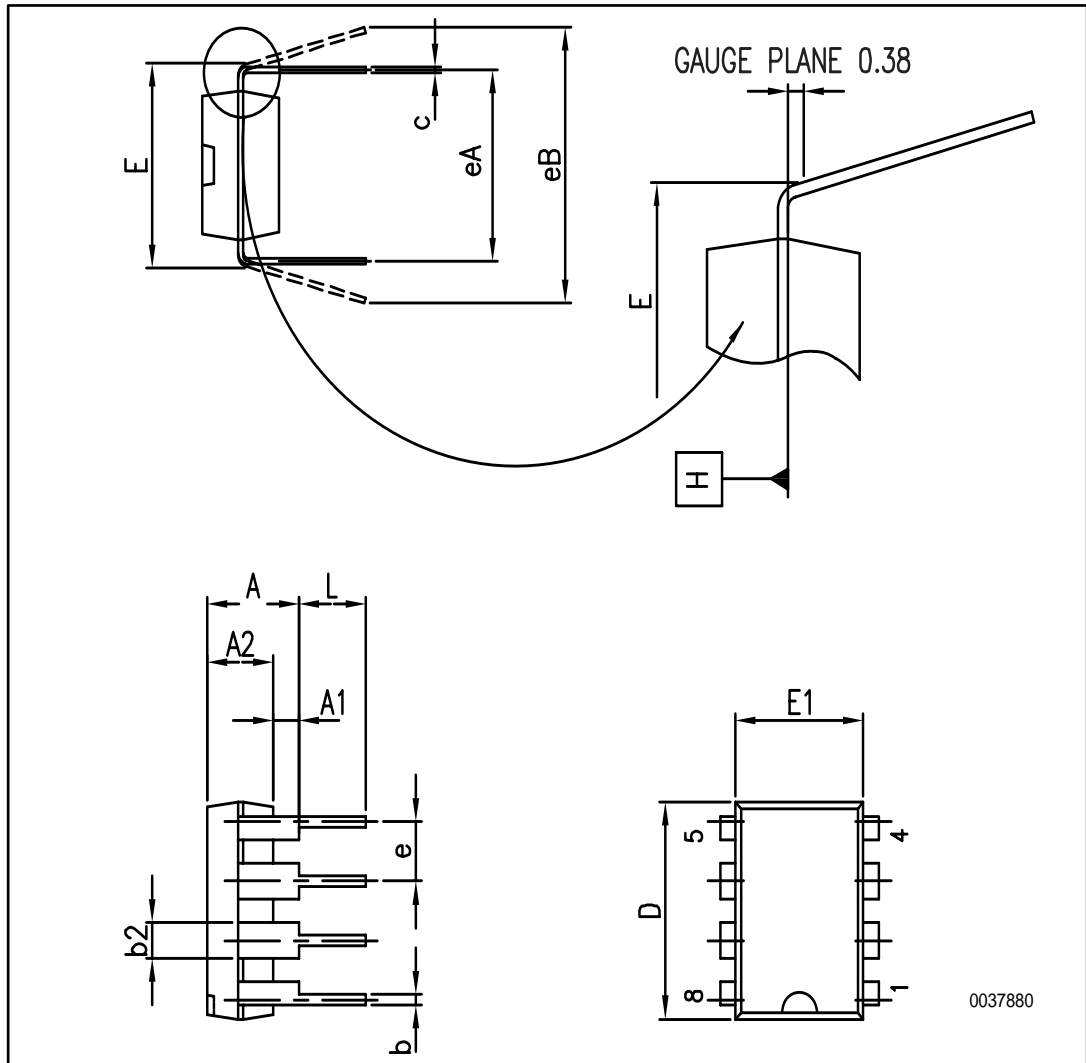

0037880

Table 6: DIP-8 package mechanical data

Dim.	mm		
	Min.	Typ.	Max.
A			5.33
A1	0.38		
A2	2.92	3.30	4.95
b	0.36	0.46	0.56
b2	1.14	1.52	1.78
c	0.20	0.25	0.36
D	9.02	9.27	10.16
E	7.62		15.75
E1	6.10	6.35	7.11
e		2.54	
eA		7.62	
eB			10.92
L	2.92	3.30	3.81

9 Revision history

Table 7: Document revision history

Date	Revision	Changes
20-Sep-2003	1	Initial release.
03-Mar-2007	2	Document reformatted, typo figure 1.
13-Jul-2015	3	The part numbers: TDE1767DP, TDE1767ADP, TDE1787DP have been moved to a separate datasheet.

IMPORTANT NOTICE – PLEASE READ CAREFULLY

STMicroelectronics NV and its subsidiaries ("ST") reserve the right to make changes, corrections, enhancements, modifications, and improvements to ST products and/or to this document at any time without notice. Purchasers should obtain the latest relevant information on ST products before placing orders. ST products are sold pursuant to ST's terms and conditions of sale in place at the time of order acknowledgement.

Purchasers are solely responsible for the choice, selection, and use of ST products and ST assumes no liability for application assistance or the design of Purchasers' products.

No license, express or implied, to any intellectual property right is granted by ST herein.

Resale of ST products with provisions different from the information set forth herein shall void any warranty granted by ST for such product.

ST and the ST logo are trademarks of ST. All other product or service names are the property of their respective owners.

Information in this document supersedes and replaces information previously supplied in any prior versions of this document.

© 2015 STMicroelectronics – All rights reserved

Looking for pricing, stock, or lifecycle information?

Click below to explore more details on WIN SOURCE:

-  [View TDE1767ADP](#) on WIN SOURCE
-  [STMicroelectronics](#) Information

Optimize Your Supply Chain with WIN SOURCE Solutions

-  Global Sourcing Solution
-  Obsolete Management
-  Cost Control Management
-  Shortage Management
-  Alternative Solution
-  Excess Inventory Management