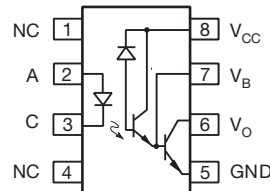
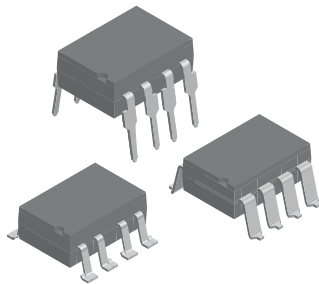




**THE DATASHEET OF  
6N139-X007**



# High Speed Optocoupler, 100 kBd, Low Input Current, Photodiode Darlington Output



## DESIGN SUPPORT TOOLS

[click logo to get started](#)



## DESCRIPTION

High common mode transient immunity and very high current ratio together with 5300  $V_{RMS}$  insulation are achieved by coupling an LED with an integrated high gain photo detector in an eight pin dual-in-line package. Separate pins for the photo diode and output stage enable TTL compatible saturation voltages with high speed operation.

Access to the base terminal allows adjustment to the gain bandwidth.

The 6N139 is suited for low power logic applications involving CMOS and low power TTL applications. A 400 % current transfer ratio with only 0.5 mA of LED current is guaranteed.

**Caution:** Due to the small geometries of this device, it should be handled with Electrostatic Discharge (ESD) precautions. Proper grounding would prevent damage further and/or degradation which may be induced by ESD.

## FEATURES

- High current transfer ratio, 500 %
- Low input current, 1.6 mA
- High common mode rejection, 500 V/ $\mu$ s
- Adjustable bandwidth-access to base
- Material categorization: for definitions of compliance please see [www.vishay.com/doc?99912](http://www.vishay.com/doc?99912)



**RoHS**  
COMPLIANT

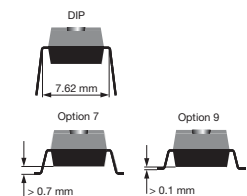
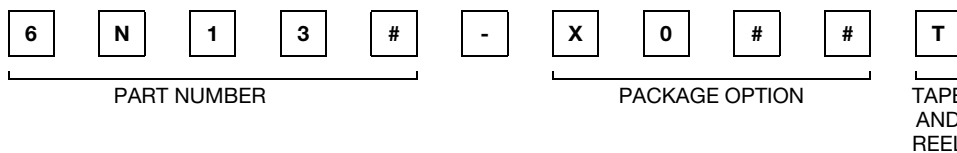
## APPLICATIONS

- Microprocessor system interface
- PLC, ATE input / output isolation
- EIA RS232 line receiver
- TTL, CMOS voltage level translation
- Multiplexed data transmission
- Digital control power supply
- Ground loop and electrical noise elimination

## AGENCY APPROVALS

- [UL 1577](#)
- [cUL](#)
- [DIN EN 60747-5-5 \(VDE 0884-5\), available with option 1](#)

## ORDERING INFORMATION



AGENCY CERTIFIED/PACKAGE	CTR (%)
	<b>UL, cUL</b>
DIP-8	<b>&gt; 500</b>
SMD-8, option 7	6N139
SMD-8, option 9	6N139-X007, 6N139-X007T
<b>UL, cUL, VDE (option 1)</b>	<b>&gt; 500</b>
DIP-8	6N139-X009, 6N139-X009T
SMD-8, option 7	6N139-X001
SMD-8, option 9	6N139-X017T
	6N139-X019T

### Note

- For additional information on the available options refer to option information



<b>ABSOLUTE MAXIMUM RATINGS</b> ( $T_{amb} = 25\text{ }^{\circ}\text{C}$ , unless otherwise specified)				
PARAMETER	TEST CONDITION	SYMBOL	VALUE	UNIT
<b>INPUT</b>				
Reverse voltage		$V_R$	5	V
Forward current		$I_F$	25	mA
Average input current		$I_{f(avg)}$	20	mA
Input power dissipation		$P_{diss}$	35	mW
<b>OUTPUT</b>				
Supply and output voltage	Pin 8 to 5, pin 6 to 5	$V_{CC}, V_O$	-0.5 to 18	V
Emitter base reverse voltage	Pin 5 to 7		0.5	V
Peak input current	50 % duty cycle - 1 ms pulse width		40	mA
Peak transient input current	$t_p \leq 1\text{ }\mu\text{s}$ , 300 pps		1	A
Output current	Pin 6	$I_O$	60	mA
Output power dissipation		$P_{diss}$	100	mW
<b>COUPLER</b>				
Storage temperature		$T_{stg}$	-55 to +150	$^{\circ}\text{C}$
Operating temperature		$T_{amb}$	-55 to +100	$^{\circ}\text{C}$
Lead soldering temperature	$t = 10\text{ s}$	$T_{sld}$	260	$^{\circ}\text{C}$

**Note**

- Stresses in excess of the absolute maximum ratings can cause permanent damage to the device. Functional operation of the device is not implied at these or any other conditions in excess of those given in the operational sections of this document. Exposure to absolute maximum ratings for extended periods of the time can adversely affect reliability

<b>ELECTRICAL CHARACTERISTICS</b> ( $T_{amb} = 25\text{ }^{\circ}\text{C}$ , unless otherwise specified)						
PARAMETER	TEST CONDITION	SYMBOL	MIN.	TYP.	MAX.	UNIT
<b>INPUT</b>						
Input forward voltage	$I_F = 1.6\text{ mA}$	$V_F$	-	1.4	1.7	V
Input reverse breakdown voltage	$I_R = 10\text{ }\mu\text{A}$	$B_{VR}$	5	-	-	V
Input capacitance	$f = 1\text{ MHz}$ , $V_F = 0$	$C_{IN}$	-	25	-	pF
Temperature coefficient of forward voltage	$I_F = 1.6\text{ mA}$		-	-1.8	-	mV/ $^{\circ}\text{C}$
<b>OUTPUT</b>						
Logic low, output voltage <sup>(1)</sup>	$I_F = 1.6\text{ mA}$ , $I_O = 8\text{ mA}$ , $V_{CC} = 4.5\text{ V}$	$V_{OL}$	-	0.1	0.4	V
	$I_F = 5\text{ mA}$ , $I_O = 15\text{ mA}$ , $V_{CC} = 4.5\text{ V}$	$V_{OL}$	-	0.15	0.4	V
	$I_F = 12\text{ mA}$ , $I_O = 24\text{ mA}$ , $V_{CC} = 4.5\text{ V}$	$V_{OL}$	-	0.25	0.4	V
Logic high, output current <sup>(1)</sup>	$I_F = 0\text{ mA}$ , $V_{CC} = 18\text{ V}$	$I_{OH}$	-	0.05	100	$\mu\text{A}$
Logic low supply current <sup>(1)</sup>	$I_F = 1.6\text{ mA}$ , $V_O = \text{OPEN}$ , $V_{CC} = 18\text{ V}$	$I_{CCL}$	-	0.2	1.5	mA
Logic high supply current <sup>(1)</sup>	$I_F = 0\text{ mA}$ , $V_O = \text{OPEN}$ , $V_{CC} = 18\text{ V}$	$I_{CCH}$	-	0.001	10	$\mu\text{A}$
<b>COUPLER</b>						
Input output insulation leakage current	45 % relative humidity, $T_{amb} = 25\text{ }^{\circ}\text{C}$ , $t = 5\text{ s}$ , $V_{IO} = 3000\text{ V}_{DC}$		-	-	1	$\mu\text{A}$
Coupling capacitance	$f = 1\text{ MHz}$	$C_{IO}$	-	0.6	-	pF

**Notes**

- Minimum and maximum values are testing requirements. Typical values are characteristics of the device and are the result of engineering evaluation. Typical values are for information only and are not part of the testing requirements

<sup>(1)</sup> Pin 7 open

**CURRENT TRANSFER RATIO**

PARAMETER	TEST CONDITION	SYMBOL	MIN.	TYP.	MAX.	UNIT
Current transfer ratio <sup>(1)</sup>	$I_F = 0.5 \text{ mA}, V_O = 0.4 \text{ V}, V_{CC} = 4.5 \text{ V}$	CTR	400	1600	-	%
	$I_F = 1.6 \text{ mA}, V_O = 0.4 \text{ V}, V_{CC} = 4.5 \text{ V}$	CTR	500	2000	-	%

**Notes**

<sup>(1)</sup> Pin 7 open

**SAFETY AND INSULATION RATINGS** ( $T_{amb} = 25 \text{ }^\circ\text{C}$ , unless otherwise specified)

PARAMETER	TEST CONDITION	SYMBOL	VALUE	UNIT
Climatic classification	According to IEC 68 part 1		55 / 100 / 21	
Comparative tracking index	Insulation group IIIa	CTI	175	
Maximum rated withstanding isolation voltage	According to UL 1577, $t = 1 \text{ min}$	$V_{ISO}$	5300	$V_{RMS}$
Maximum transient isolation voltage	According to DIN EN 60747-5-5	$V_{IOTM}$	8000	$V_{peak}$
Maximum repetitive peak isolation voltage	According to DIN EN 60747-5-5	$V_{IORM}$	890	$V_{peak}$
Isolation resistance	$T_{amb} = 25 \text{ }^\circ\text{C}, V_{IO} = 500 \text{ V}$	$R_{IO}$	$\geq 10^{12}$	$\Omega$
	$T_{amb} = 100 \text{ }^\circ\text{C}, V_{IO} = 500 \text{ V}$	$R_{IO}$	$\geq 10^{11}$	$\Omega$
Output safety power		$P_{SO}$	500	mW
Input safety current		$I_{SI}$	300	mA
Input safety temperature		$T_S$	175	$^\circ\text{C}$
Creepage distance	DIP-8		$\geq 7$	mm
Clearance distance			$\geq 7$	mm
Creepage distance	SMD-8, option 7, SMD-8, option 9		$\geq 8$	mm
Clearance distance			$\geq 8$	mm
Insulation thickness		DTI	$\geq 0.4$	mm

**Note**

- As per IEC 60747-5-5, § 7.4.3.8.2, this optocoupler is suitable for "safe electrical insulation" only within the safety ratings. Compliance with the safety ratings shall be ensured by means of protective circuits

**SWITCHING CHARACTERISTICS**

PARAMETER	TEST CONDITION	SYMBOL	MIN.	TYP.	MAX.	UNIT
Propagation delay time to logic low at output	$I_F = 0.5 \text{ mA}, R_L = 4.7 \text{ k}\Omega$	$t_{PHL}$	-	6	25	$\mu\text{s}$
	$I_F = 12 \text{ mA}, R_L = 270 \Omega$	$t_{PHL}$	-	0.6	1	$\mu\text{s}$
Propagation delay time to logic high at output	$I_F = 0.5 \text{ mA}, R_L = 4.7 \text{ k}\Omega$	$t_{PLH}$	-	4	60	$\mu\text{s}$
Propagation delay time to logic high at output	$I_F = 12 \text{ mA}, R_L = 270 \Omega$	$t_{PLH}$	-	1.5	7	$\mu\text{s}$

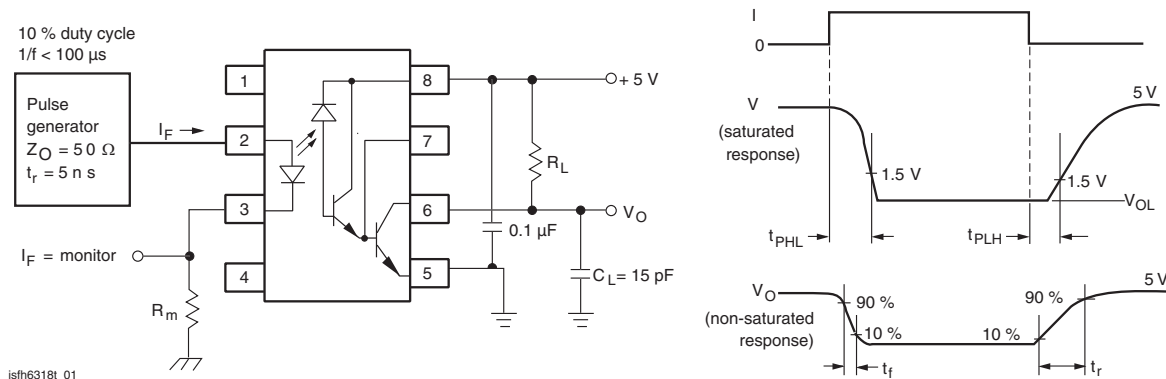


Fig. 1 - Switching Test Circuit

COMMON MODE TRANSIENT IMMUNITY						
PARAMETER	TEST CONDITION	SYMBOL	MIN.	TYP.	MAX.	UNIT
Common mode transient immunity, logic high level output <sup>(1)</sup>	$I_F = 0 \text{ mA}$ , $R_L = 2.2 \text{ k}\Omega$ , $R_{CC} = 0$ , $ V_{CM}  = 10 \text{ V}_{P-P}$	$ CM_H $	-	500	-	$\text{V}/\mu\text{s}$
Common mode transient immunity, logic low level output <sup>(1)</sup>	$I_F = 16 \text{ mA}$ , $R_L = 2.2 \text{ k}\Omega$ , $R_{CC} = 0$ , $ V_{CM}  = 10 \text{ V}_{P-P}$	$ CM_L $	-	- 500	-	$\text{V}/\mu\text{s}$

**Note**

<sup>(1)</sup> In applications where  $dV/dt$  may exceed  $50\,000 \text{ V}/\mu\text{s}$  (such as state discharge) a series resistor,  $R_{CC}$  should be included to protect  $I_C$  from destructively high surge currents. The recommend value is  $R_{CC} \equiv [(1 \text{ V})/(0.15 I_F \text{ (mA)})] \text{ k}\Omega$

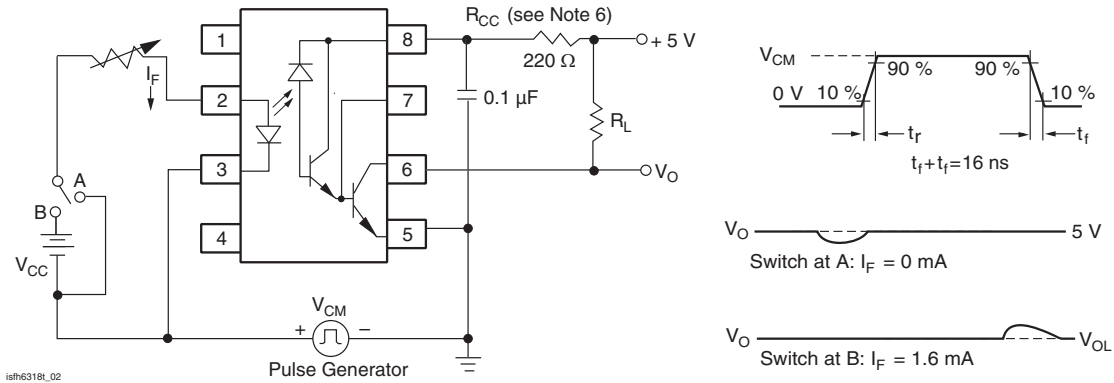


Fig. 2 - Test Circuit for Transient Immunity and Typical Waveforms

**TYPICAL CHARACTERISTICS** ( $T_{amb} = 25 \text{ }^\circ\text{C}$ , unless otherwise specified)

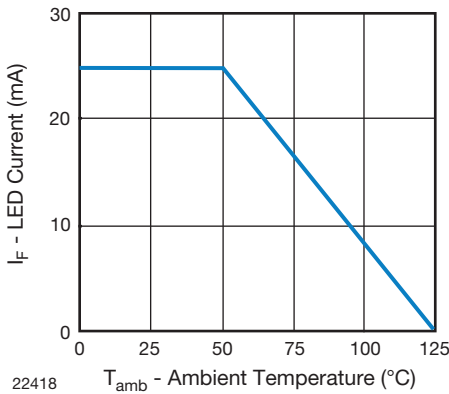


Fig. 2 - Permissible Forward LED Current vs. Temperature

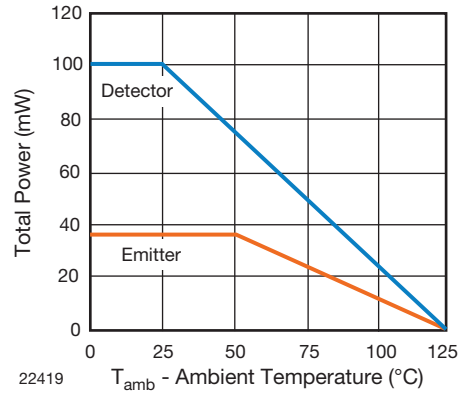
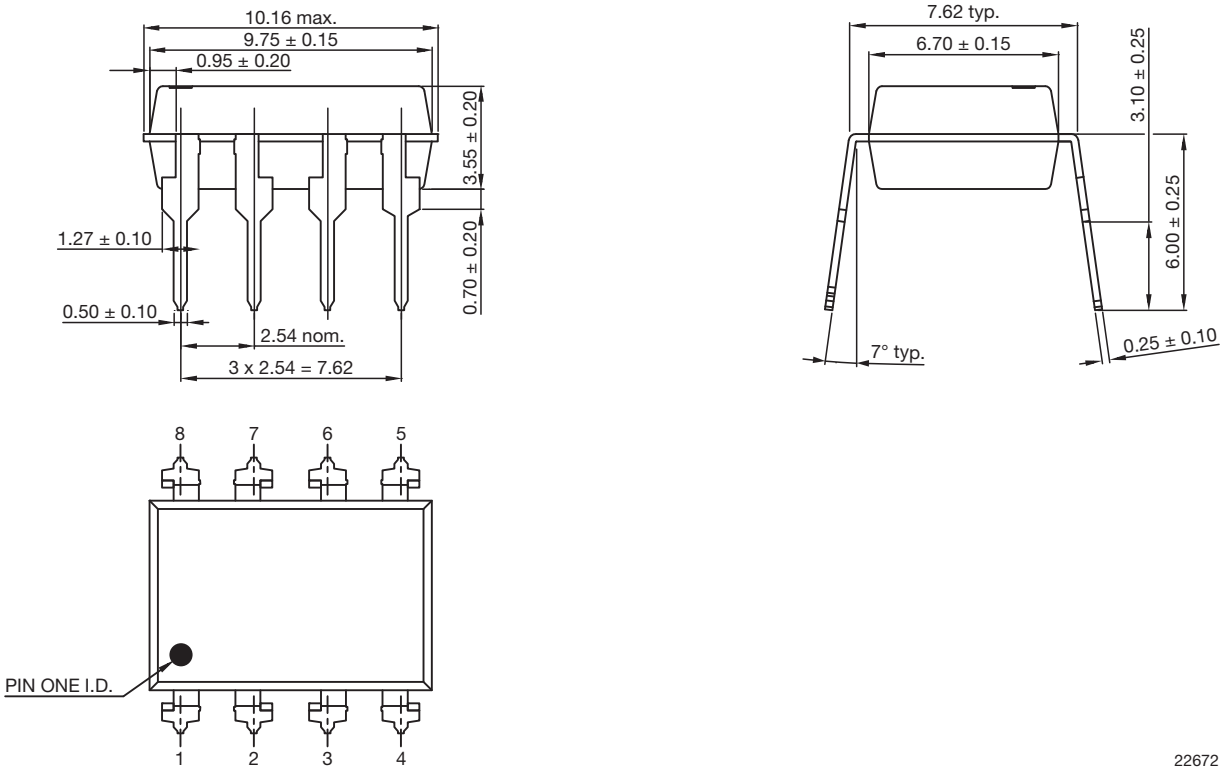


Fig. 3 - Permissible Power Dissipation vs. Temperature



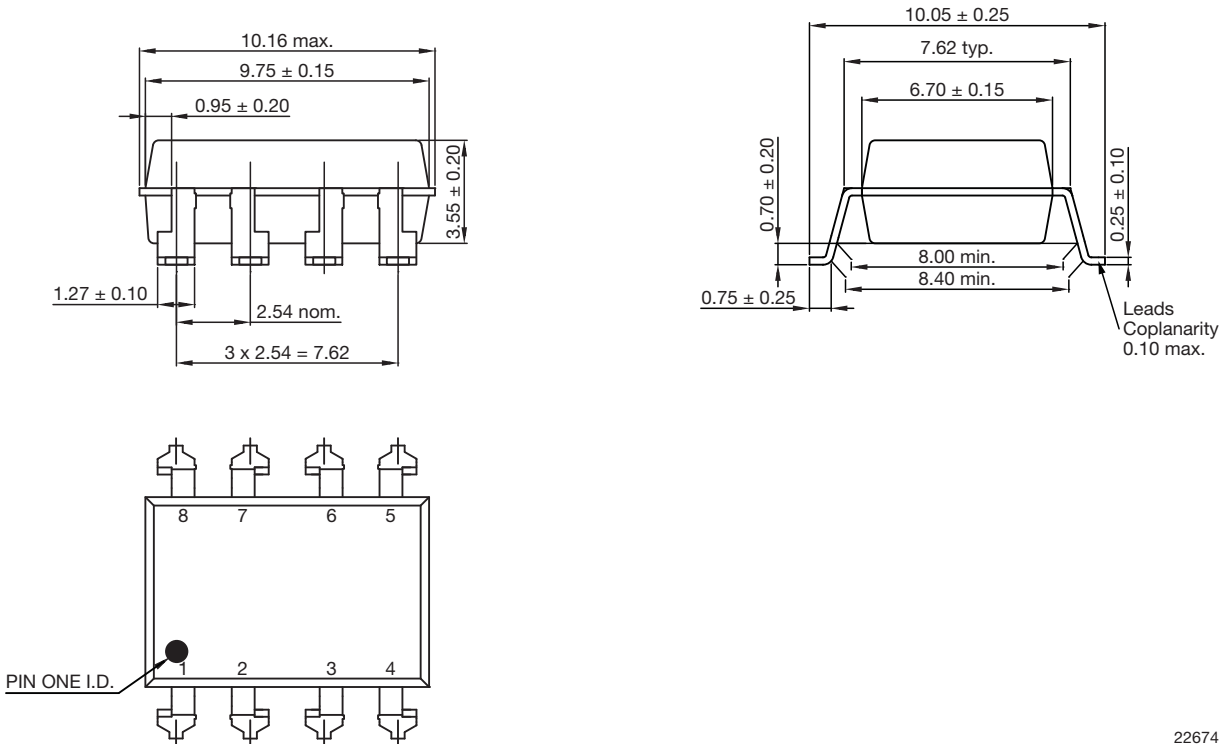
**PACKAGE DIMENSIONS** (in millimeters)

**DIP-8**



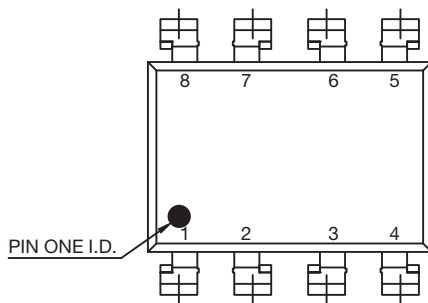
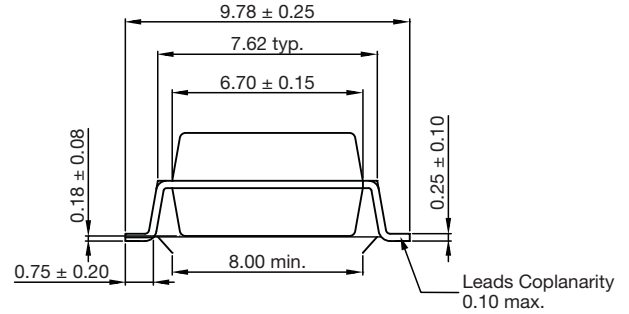
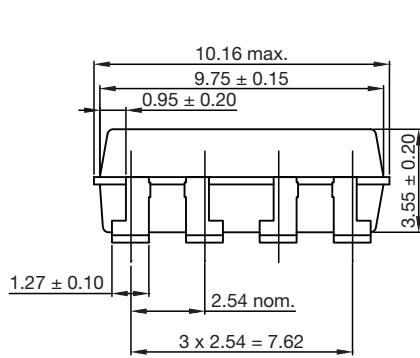
22672

**SMD-8, Option 7**



22674

SMD-8, Option 9



22675

PACKAGE MARKING

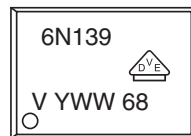


Fig. 3 - Example of 6N139-X017T

Note

- VDE logo is only marked on option 1 parts
- Tape and reel suffix (T) is not part of the package marking

**PACKING INFORMATION** (in millimeters)

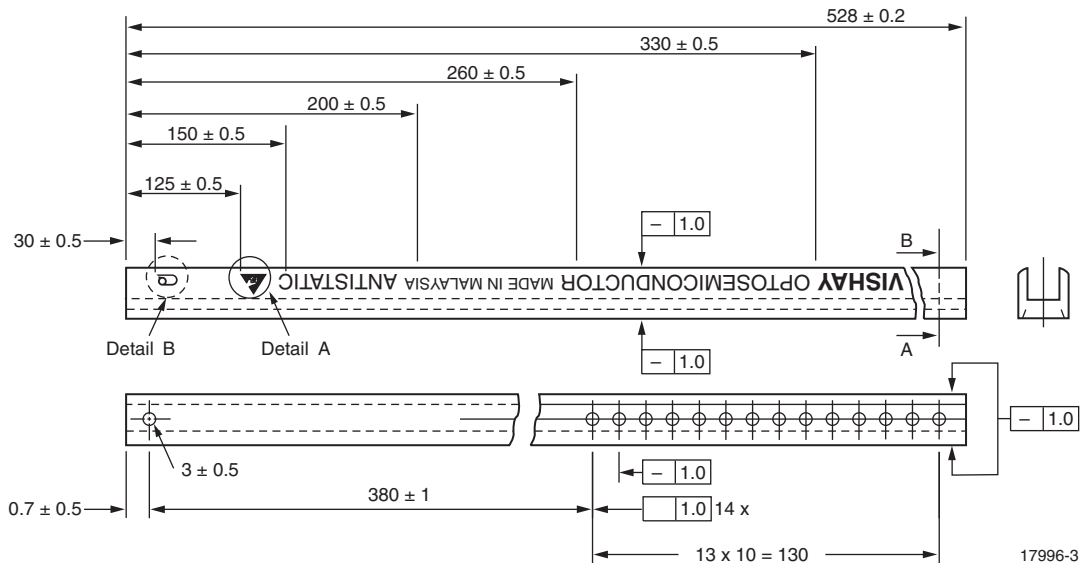
**Tube**


Fig. 4 - Shipping Tube Specifications for DIP-8 Packages

DEVICES PER TUBS			
TYPE	UNITS/TUBE	TUBES/BOX	UNITS/BOX
DIP-8	50	40	2000

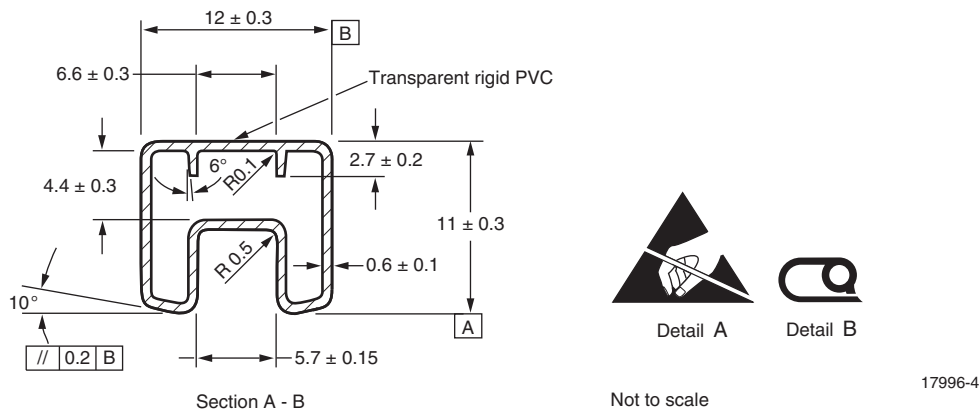
**DIP-8**


Fig. 5 - Tube Shipping Medium

Tape and Reel

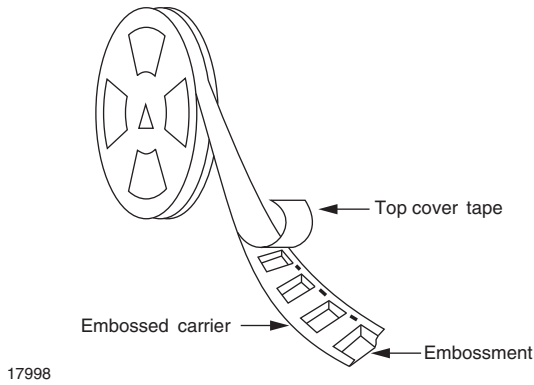


Fig. 6 - Tape and Reel Shipping Medium

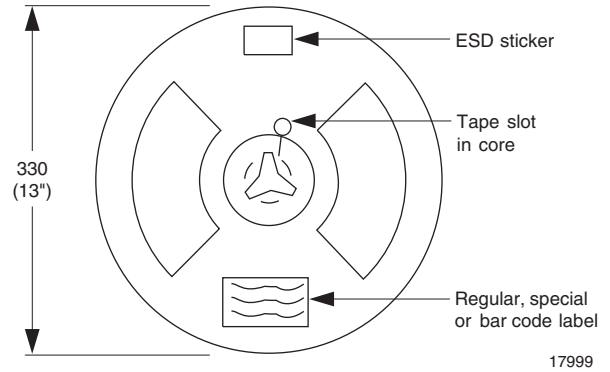


Fig. 7 - Tape and Reel Shipping Medium

SMD-8 (option 7)

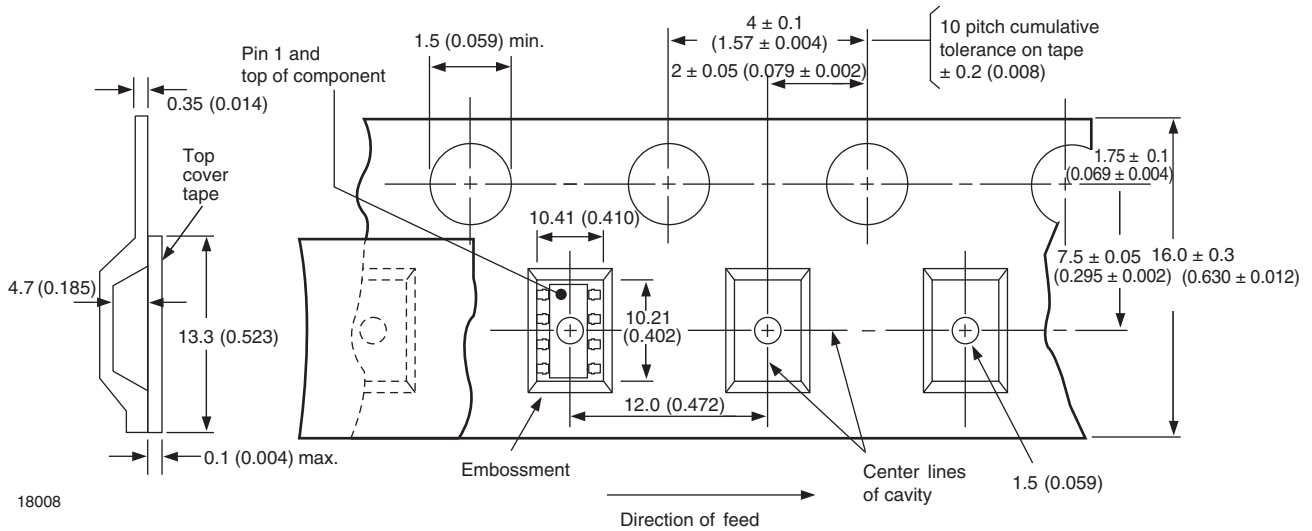


Fig. 8 - Tape and Reel Packing (1000 pieces on Reel)

SMD-8 (option 9)

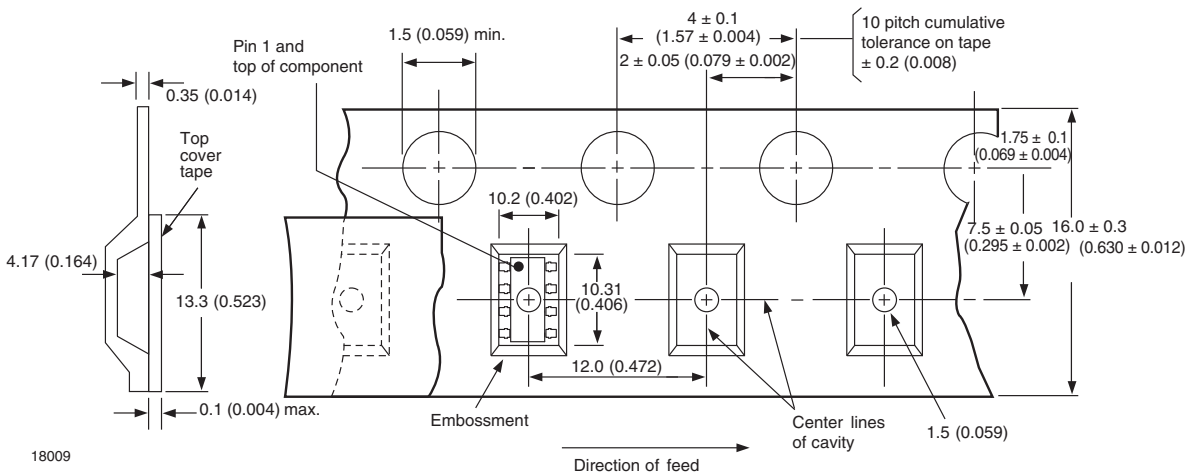
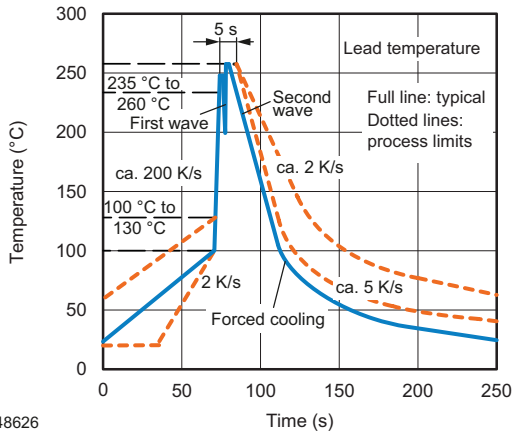


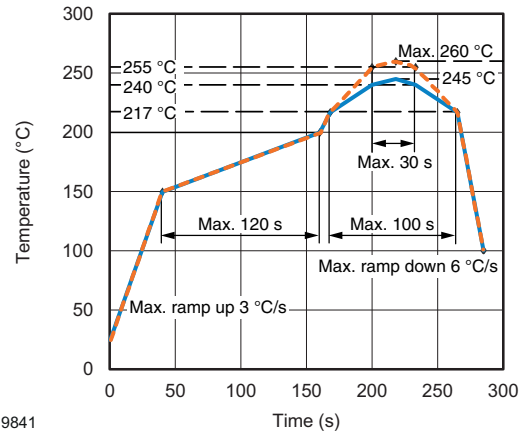
Fig. 9 - Tape and Reel Shipping Medium

**SOLDER PROFILES**



948626

Fig. 10 - Wave Soldering Double Wave Profile According to J-STD-020 for DIP-8 Devices



19841

Fig. 11 - Lead (Pb)-free Reflow Solder Profile According to J-STD-020 for SMD-8 Devices

**HANDLING AND STORAGE CONDITIONS**

ESD level: HBM class 2

Floor life: unlimited

Conditions:  $T_{amb} < 30\text{ }^{\circ}\text{C}$ , RH < 85 %

Moisture sensitivity level 1, according to J-STD-020



## **Disclaimer**

ALL PRODUCT, PRODUCT SPECIFICATIONS AND DATA ARE SUBJECT TO CHANGE WITHOUT NOTICE TO IMPROVE RELIABILITY, FUNCTION OR DESIGN OR OTHERWISE.

Vishay Intertechnology, Inc., its affiliates, agents, and employees, and all persons acting on its or their behalf (collectively, "Vishay"), disclaim any and all liability for any errors, inaccuracies or incompleteness contained in any datasheet or in any other disclosure relating to any product.

Vishay makes no warranty, representation or guarantee regarding the suitability of the products for any particular purpose or the continuing production of any product. To the maximum extent permitted by applicable law, Vishay disclaims (i) any and all liability arising out of the application or use of any product, (ii) any and all liability, including without limitation special, consequential or incidental damages, and (iii) any and all implied warranties, including warranties of fitness for particular purpose, non-infringement and merchantability.

Statements regarding the suitability of products for certain types of applications are based on Vishay's knowledge of typical requirements that are often placed on Vishay products in generic applications. Such statements are not binding statements about the suitability of products for a particular application. It is the customer's responsibility to validate that a particular product with the properties described in the product specification is suitable for use in a particular application. Parameters provided in datasheets and / or specifications may vary in different applications and performance may vary over time. All operating parameters, including typical parameters, must be validated for each customer application by the customer's technical experts. Product specifications do not expand or otherwise modify Vishay's terms and conditions of purchase, including but not limited to the warranty expressed therein.

Except as expressly indicated in writing, Vishay products are not designed for use in medical, life-saving, or life-sustaining applications or for any other application in which the failure of the Vishay product could result in personal injury or death. Customers using or selling Vishay products not expressly indicated for use in such applications do so at their own risk. Please contact authorized Vishay personnel to obtain written terms and conditions regarding products designed for such applications.

No license, express or implied, by estoppel or otherwise, to any intellectual property rights is granted by this document or by any conduct of Vishay. Product names and markings noted herein may be trademarks of their respective owners.

## Looking for pricing, stock, or lifecycle information?

Click below to explore more details on WIN SOURCE:

 [View 6N139-X007 on WIN SOURCE](#)

 [Vishay Information](#)

## Optimize Your Supply Chain with WIN SOURCE Solutions

-  Global Sourcing Solution
-  Obsolete Management
-  Cost Control Management
-  Shortage Management
-  Alternative Solution
-  Excess Inventory Management