



# THE DATASHEET OF NB4L52MNG



# 2.5 V/3.3 V/5.0 V Differential Data/Clock D Flip-Flop with Reset

Multi-Level Inputs to LVPECL Translator w/ Internal Termination

## NB4L52

The NB4L52 is a differential Data and Clock D flip-flop with a differential asynchronous Reset. The differential inputs incorporate internal 50 Ω termination resistors and will accept PECL, LVPECL, LVCMOS, LVTTTL, CML, or LVDS logic levels. When Clock transitions from Low to High, Data will be transferred to the differential LVPECL outputs. The differential Clock inputs allow the NB4L52 to also be used as a negative edge triggered device. The device is housed in a small 3x3 mm 16 pin QFN package.

### Features

- Maximum Input Clock Frequency > 4 GHz Typical
- 330 ps Typical Propagation Delay
- 145 ps Typical Rise and Fall Times
- Differential LVPECL Outputs, 750 mV Peak-to-Peak, Typical
- Operating Range:  $V_{CC} = 2.375\text{ V}$  to  $5.5\text{ V}$  with  $V_{EE} = 0\text{ V}$
- Internal Input Termination Resistors, 50 Ω
- Functionally Compatible with Existing 2.5 V/3.3 V/5.0 V LVEL, LVEP, EP, and SG Devices
- $-40^{\circ}\text{C}$  to  $+85^{\circ}\text{C}$  Ambient Operating Temperature
- These are Pb-Free Devices

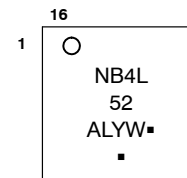

Figure 2. Pinout (Top View)



QFN-16  
MN SUFFIX  
CASE 485G

### MARKING DIAGRAM\*



- A = Assembly Location
- L = Wafer Lot
- Y = Year
- W = Work Week
- = Pb-Free Package

(Note: Microdot may be in either location)

\*For additional marking information, refer to Application Note [AND8002/D](#).

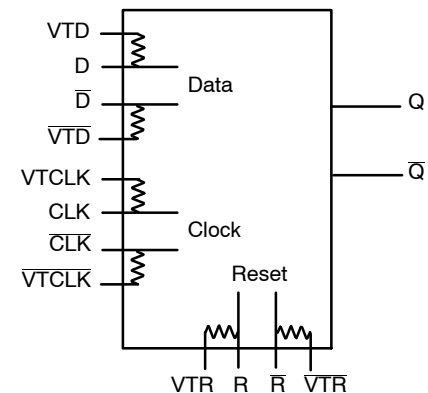

Figure 1. Logic Diagram

Table 1. TRUTH TABLE

R	D	CLK	Q
H	x	x	L
L	L	Z	L
L	H	Z	H

Z = LOW to HIGH Transition  
x = Don't Care

### ORDERING INFORMATION

See detailed ordering and shipping information in the package dimensions section on page 6 of this data sheet.

# NB4L52

**Table 2. PIN DESCRIPTION**

Pin	Name	I/O	Description
1	$V_{TD}$	-	Internal 50 $\Omega$ Termination Pin. (See Table 4)
2	D	ECL, CML, LVCMOS, LVDS, LVTTTL Input	Noninverted Differential Input. (Note 1)
3	$\bar{D}$	ECL, CML, LVCMOS, LVDS, LVTTTL Input	Inverted Differential Input. (Note 1)
4	$\sqrt{V_{TD}}$	-	Internal 50 $\Omega$ Termination Pin. (See Table 4)
5	$V_{TCLK}$	-	Internal 50 $\Omega$ Termination Pin. (See Table 4)
6	CLK	ECL, CML, LVCMOS, LVDS, LVTTTL Input	Noninverted Differential Input. (Note 1)
7	$\overline{CLK}$	ECL, CML, LVCMOS, LVDS, LVTTTL Input	Inverted Differential Input. (Note 1)
8	$\sqrt{V_{TCLK}}$	-	Internal 50 $\Omega$ Termination Pin. (See Table 4)
9	$V_{EE}$	-	Negative Supply Voltage
10	$\bar{Q}$	ECL Output	Inverted Differential Output. Typically terminated with 50 $\Omega$ resistor to $V_{CC} - 2.0$ V.
11	Q	ECL Output	Noninverted Differential Output. Typically terminated with 50 $\Omega$ resistor to $V_{CC} - 2.0$ V.
12	$V_{CC}$	-	Positive Supply Voltage
13	$V_{TR}$	-	Internal 50 $\Omega$ Termination Pin. (See Table 4)
14	R	LVECL, LVCMOS, LVTTTL Input	Noninverted Differential Reset Input. (Note 1)
15	$\bar{R}$	LVECL, LVCMOS, LVTTTL Input	Inverted Differential Reset Input. (Note 1)
16	$\sqrt{V_{TR}}$	-	Internal 50 $\Omega$ Termination Pin. (See Table 4)
-	EP	-	The Exposed Pad (EP) on the QFN-16 package bottom is thermally connected to the die for improved heat transfer out of package. The pad is not electrically connected to the die, but is recommended to be electrically and thermally connected to $V_{EE}$ on the PC board.

1. In the differential configuration when the input termination pin ( $V_{TD}$ ,  $\sqrt{V_{TD}}$ ,  $V_{TR}$ ,  $\sqrt{V_{TR}}$ ,  $V_{TCLK}$ ,  $\sqrt{V_{TCLK}}$ ) are connected to a common termination voltage or left open, and if no signal is applied on D/ $\bar{D}$ , CLK/ $\overline{CLK}$ , R/ $\bar{R}$  input then the device will be susceptible to self-oscillation.

**Table 3. ATTRIBUTES**

Characteristic	Value	
ESD Protection	Human Body Model	> 2 kV
	Machine Model	> 200 V
	Charged Device Model	> 1 kV
Moisture Sensitivity (Note 2)	Pb Pkg	Pb-Free Pkg
	QFN-16	Level 1
Flammability Rating Oxygen Index: 28 to 34	UL 94 V-0 @ 0.125 in	
Transistor Count	164	
Meets or exceeds JEDEC Spec EIA/JESD78 IC Latchup Test		

2. For additional information, see Application Note AND8003/D.

# NB4L52

**Table 4. MAXIMUM RATINGS**

Symbol	Parameter	Condition 1	Condition 2	Rating	Unit
V <sub>CC</sub>	Positive Power Supply	V <sub>EE</sub> = 0 V		6.0	V
V <sub>EE</sub>	Negative Power Supply	V <sub>CC</sub> = 0 V		-6.0	V
V <sub>IO</sub>	Positive Input/Output Negative Input/Output	V <sub>EE</sub> = 0 V V <sub>CC</sub> = 0 V	V <sub>I</sub> ≤ V <sub>CC</sub> V <sub>I</sub> ≥ V <sub>EE</sub>	6.0 -6.0	V V
I <sub>IN</sub>	Input Current Through R <sub>T</sub> (50 Ω Resistor)	Static Surge		45 80	mA mA
I <sub>out</sub>	Output Current	Continuous Surge		25 50	mA mA
T <sub>A</sub>	Operating Temperature Range			-40 to +85	°C
T <sub>stg</sub>	Storage Temperature Range			-65 to +150	°C
θ <sub>JA</sub>	Thermal Resistance (Junction-to-Ambient)	0 LFPM 500 LFPM	16 QFN 16 QFN	42 35	°C/W °C/W
θ <sub>JC</sub>	Thermal Resistance (Junction-to-Case)	2S2P (Note 3)	16 QFN	4.0	°C/W
T <sub>sol</sub>	Wave Solder Pb-Free			265	°C

Stresses exceeding those listed in the Maximum Ratings table may damage the device. If any of these limits are exceeded, device functionality should not be assumed, damage may occur and reliability may be affected.

3. JEDEC standard multilayer board – 2S2P (2 signal, 2 power) with 8 filled thermal vias under exposed pad.

**Table 5. DC CHARACTERISTICS, CLOCK INPUTS, LVPECL OUTPUTS**

(V<sub>CC</sub> = 2.375 V to 5.5 V, V<sub>EE</sub> = 0 V or V<sub>CC</sub> = 0 V, V<sub>EE</sub> = -2.375 to -5.5 V, T<sub>A</sub> = -40°C to +85°C)

Symbol	Characteristic	Min	Typ	Max	Unit
I <sub>EE</sub>	Power Supply Current (Inputs and Outputs Open)	-	16	25	mA
V <sub>OH</sub>	Output HIGH Voltage (Note 4, 5) V <sub>CC</sub> = 5.0 V V <sub>CC</sub> = 3.3 V V <sub>CC</sub> = 2.5 V	V <sub>CC</sub> - 1145 3855 2155 1355	V <sub>CC</sub> - 1020 3980 2280 1480	V <sub>CC</sub> - 895 4105 2405 1605	mV
V <sub>OL</sub>	Output LOW Voltage (Note 4, 5) V <sub>CC</sub> = 5.0V V <sub>CC</sub> = 3.3V V <sub>CC</sub> = 2.5V	V <sub>CC</sub> - 1945 3055 1355 555	V <sub>CC</sub> - 1770 3230 1530 730	V <sub>CC</sub> - 1600 3400 1700 900	mV

**DIFFERENTIAL INPUT DRIVEN SINGLE-ENDED** (Figures 4 & 7)

V <sub>th</sub>	Input Threshold Reference Voltage Range (Note 6)	1050	-	V <sub>CC</sub> - 150	mV
V <sub>IH</sub>	Single-ended Input HIGH Voltage	V <sub>th</sub> + 150	-	V <sub>CC</sub>	mV
V <sub>IL</sub>	Single-ended Input LOW Voltage	V <sub>EE</sub>	-	V <sub>th</sub> - 150	mV

**DIFFERENTIAL INPUT DRIVEN DIFFERENTIALLY** (Figures 5, 6 & 8)

V <sub>IHD</sub>	Differential Input HIGH Voltage	1200	-	V <sub>CC</sub>	mV
V <sub>ILD</sub>	Differential Input LOW Voltage	V <sub>EE</sub>	-	V <sub>CC</sub> - 150	mV
V <sub>CMR</sub>	Input Common Mode Range (Differential Configuration) (Note 7)	1125	-	V <sub>CC</sub> - 75	mV
V <sub>ID</sub>	Differential Input Voltage (V <sub>IHD</sub> - V <sub>ILD</sub> )	150	-	V <sub>CC</sub>	mV
I <sub>IH</sub>	Input HIGH Current D / $\bar{D}$ , CLK / $\bar{CLK}$ , R / $\bar{R}$ (VTx/VTx Open)	-150	-	150	μA
I <sub>IL</sub>	Input LOW Current D / $\bar{D}$ , CLK / $\bar{CLK}$ , R / $\bar{R}$ (VTx/VTx Open)	-150	-	150	μA
R <sub>TIN</sub>	Internal Input Termination Resistor	40	50	60	Ω

NOTE: Device will meet the specifications after thermal equilibrium has been established when mounted in a test socket or printed circuit board with maintained transverse airflow greater than 500 lfm.

4. LVPECL outputs loaded with 50 Ω to V<sub>CC</sub> - 2.0 V for proper operation.

5. Input and output parameters vary 1:1 with V<sub>CC</sub>.

6. V<sub>th</sub> is applied to the complementary input when operating in single-ended mode.

7. V<sub>CMRMIN</sub> varies 1:1 with V<sub>EE</sub>, V<sub>CMRMAX</sub> varies 1:1 with V<sub>CC</sub>. The V<sub>CMR</sub> range is referenced to the most positive side of the differential input signal.

# NB4L52

**Table 6. AC CHARACTERISTICS**  $V_{CC} = 2.375\text{ V to }5.5\text{ V}$ ;  $V_{EE} = 0\text{ V or }V_{CC} = 0\text{ V}$ ,  $V_{EE} = -2.375\text{ to }-5.5\text{ V}$  (Note 8)

Symbol	Characteristic	-40°C			25°C			85°C			Unit			
		Min	Typ	Max	Min	Typ	Max	Min	Typ	Max				
$V_{OUTPP}$	Output Voltage Amplitude (@ $V_{INPPmin}$ ) (Note 10) (See Figure 4)	$f_{in} \leq 2.0\text{ GHz}$	530	770	-	530	780	-	530	760	-	mV		
		$f_{in} \leq 3.0\text{ GHz}$	490	720	-	490	730	-	490	680	-			
		$f_{in} \leq 4.0\text{ GHz}$	380	580	-	380	580	-	380	530	-			
$t_{PLH}$ , $t_{PHL}$	Propagation Delay to Output Differential	CLK to Q, R to Q			300	400	500	300	400	500	300	400	500	ps
$t_s$	Setup Time	100	-	-	100	-	-	100	-	-	-	-	ps	
$t_h$	Hold Time	50	-	-	50	-	-	50	-	-	-	-	ps	
$t_{RR}$	Reset Recovery	400	-	-	400	-	-	400	-	-	-	-	ps	
$t_{PW}$	Minimum Pulse Width	R/R			250	-	-	250	-	-	250	-	-	ps
$t_{JITTER}$	RMS Random Clock Jitter (Note 9)	$f_{in} \leq 2.0\text{ GHz}$	-	1	-	-	1	-	-	1	-	-	ps	
		$f_{in} \leq 3.0\text{ GHz}$	-	1	-	-	1	-	-	1	-	-		
		$f_{in} \leq 4.0\text{ GHz}$	-	1	-	-	1	-	-	1	-	-		
$V_{INPP}$	Input Voltage Swing/Sensitivity (Differential Configuration) (Note 10)	150	-	2800	150	-	2800	150	-	2800	-	-	mV	
$t_r$ , $t_f$	Output Rise/Fall Times @ 0.5 GHz (20% - 80%)	80	135	190	80	145	190	80	155	190	-	-	ps	

NOTE: Device will meet the specifications after thermal equilibrium has been established when mounted in a test socket or printed circuit board with maintained transverse airflow greater than 500 lfpm.

8. Measured by forcing  $V_{INPP}$  (MIN) from a 50% duty cycle clock source. All loading with an external  $R_L = 50\ \Omega$  to  $V_{CC} - 2.0\text{ V}$ . Input edge rates 40 ps (20% - 80%).
9. Additive RMS jitter with 50% duty cycle clock signal.
10. Input and output voltage swing is a single-ended measurement operating in differential mode.

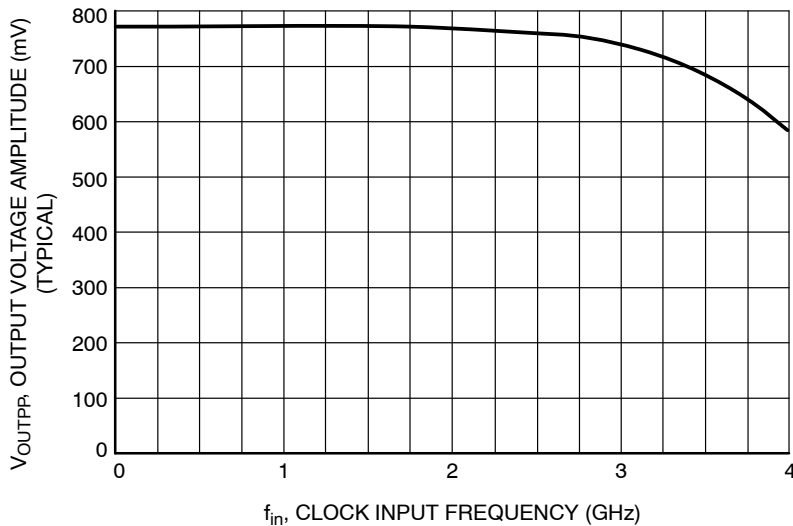

**Figure 3. Output Voltage Amplitude ( $V_{OUTPP}$ ) vs. Clock Input Frequency at Ambient Temperature (Typical).**

# NB4L52

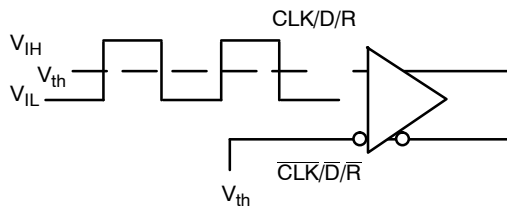

Figure 4. Differential Input Driven Single-Ended

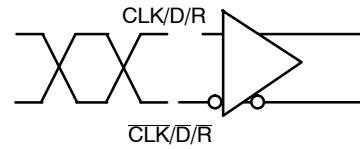

Figure 5. Differential Inputs Driven Differentially

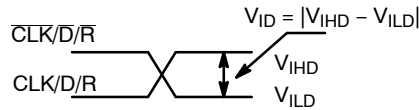

Figure 6. Differential Inputs Driven Differentially

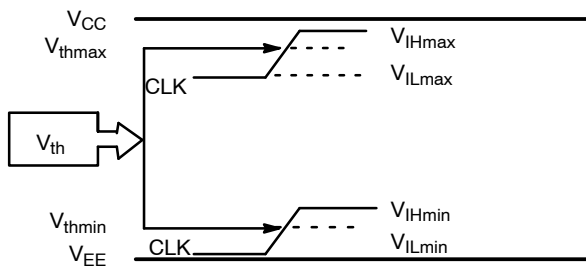

Figure 7.  $V_{th}$  Diagram

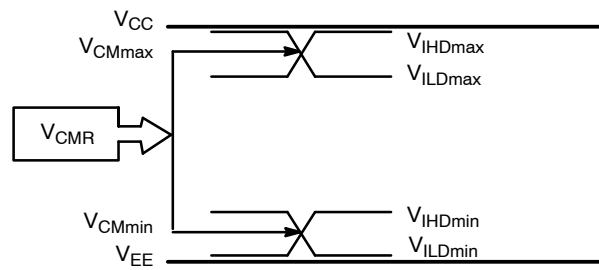

Figure 8.  $V_{CMR}$  Diagram

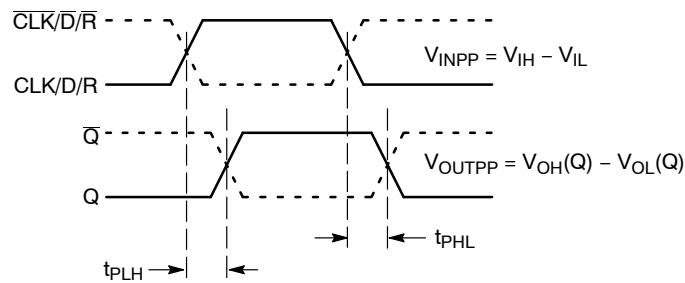
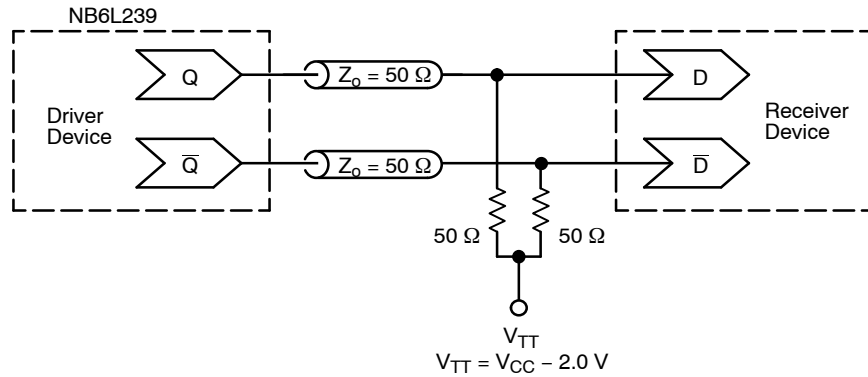

Figure 9. AC Reference Measurement

## NB4L52



**Figure 10. Typical Termination for Output Driver and Device Evaluation**  
 (See Application Note AND8020/D – Termination of ECL Logic Devices.)

### ORDERING INFORMATION

Device	Package	Shipping <sup>†</sup>
NB4L52MNG	QFN-16, 3 x 3 mm (Pb-Free)	123 Units / Rail
NB4L52MNR2G	QFN-16, 3 x 3 mm (Pb-Free)	3000 / Tape & Reel

<sup>†</sup>For information on tape and reel specifications, including part orientation and tape sizes, please refer to our Tape and Reel Packaging Specifications Brochure, [BRD8011/D](#).

### Resource Reference of Application Notes

- AN1405/D** – ECL Clock Distribution Techniques
- AN1406/D** – Designing with PECL (ECL at +5.0 V)
- AN1503/D** – ECLinPS I/O SPICE Modeling Kit
- AN1504/D** – Metastability and the ECLinPS Family
- AN1568/D** – Interfacing Between LVDS and ECL
- AN1672/D** – The ECL Translator Guide
- AND8001/D** – Odd Number Counters Design
- AND8002/D** – Marking and Date Codes
- AND8020/D** – Termination of ECL Logic Devices
- AND8066/D** – Interfacing with ECLinPS
- AND8090/D** – AC Characteristics of ECL Devices

The products described herein (NB4L52), may be covered by U.S. patents including 6,362,644. There may be other patents pending.

# MECHANICAL CASE OUTLINE PACKAGE DIMENSIONS



SCALE 2:1

**QFN16 3x3, 0.5P**  
CASE 485G  
ISSUE G

DATE 08 OCT 2021

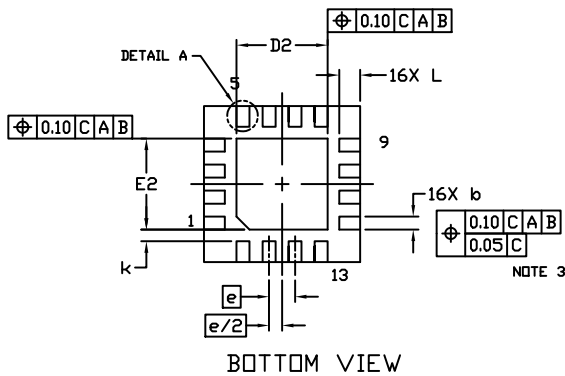
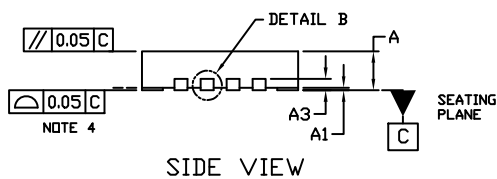
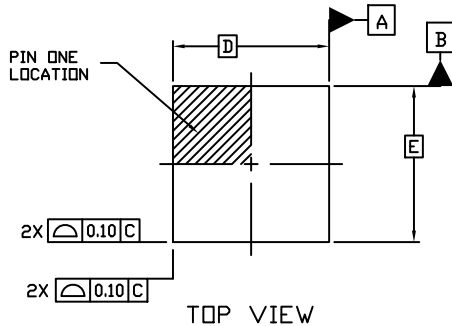

**NOTES:**

1. DIMENSIONING AND TOLERANCING PER ASME Y14.5M, 1994.
2. CONTROLLING DIMENSION: MILLIMETERS
3. DIMENSION *b* APPLIES TO PLATED TERMINAL AND IS MEASURED BETWEEN 0.15 AND 0.30 MM FROM THE TERMINAL TIP.
4. COPLANARITY APPLIES TO THE EXPOSED PAD AS WELL AS THE TERMINALS.

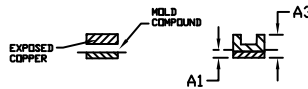

DETAIL B  
ALTERNATE  
CONSTRUCTIONS

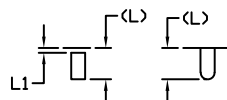

DETAIL A  
ALTERNATE TERMINAL  
CONSTRUCTIONS

DIM	MILLIMETERS		
	MIN.	NDM.	MAX.
A	0.80	0.90	1.00
A1	0.00	0.03	0.05
A3	0.20 REF		
<i>b</i>	0.18	0.24	0.30
D	3.00 BSC		
D2	1.65	1.75	1.85
E	3.00 BSC		
E2	1.65	1.75	1.85
<i>e</i>	0.50 BSC		
<i>k</i>	0.18 TYP		
L	0.30	0.40	0.50
L1	0.00	0.08	0.15

**MOUNTING FOOTPRINT**

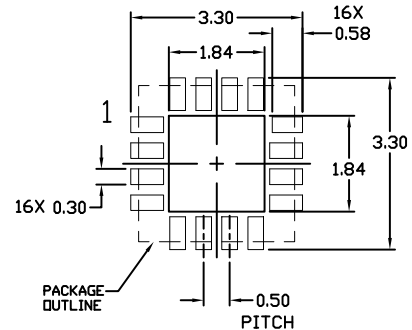

**GENERIC MARKING DIAGRAM\***

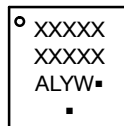

- XXXXX = Specific Device Code
- A = Assembly Location
- L = Wafer Lot
- Y = Year
- W = Work Week
- = Pb-Free Package

(Note: Microdot may be in either location)

\*This information is generic. Please refer to device data sheet for actual part marking. Pb-Free indicator, "G" or microdot "▪", may or may not be present. Some products may not follow the Generic Marking.

<b>DOCUMENT NUMBER:</b>	<b>98AON04795D</b>	Electronic versions are uncontrolled except when accessed directly from the Document Repository. Printed versions are uncontrolled except when stamped "CONTROLLED COPY" in red.
<b>DESCRIPTION:</b>	<b>QFN16 3X3, 0.5P</b>	<b>PAGE 1 OF 1</b>

onsemi and ONSEMI are trademarks of Semiconductor Components Industries, LLC dba onsemi or its subsidiaries in the United States and/or other countries. onsemi reserves the right to make changes without further notice to any products herein. onsemi makes no warranty, representation or guarantee regarding the suitability of its products for any particular purpose, nor does onsemi assume any liability arising out of the application or use of any product or circuit, and specifically disclaims any and all liability, including without limitation special, consequential or incidental damages. onsemi does not convey any license under its patent rights nor the rights of others.

**onsemi**, **Onsemi**, and other names, marks, and brands are registered and/or common law trademarks of Semiconductor Components Industries, LLC dba "**onsemi**" or its affiliates and/or subsidiaries in the United States and/or other countries. **onsemi** owns the rights to a number of patents, trademarks, copyrights, trade secrets, and other intellectual property. A listing of **onsemi**'s product/patent coverage may be accessed at [www.onsemi.com/site/pdf/Patent-Marking.pdf](http://www.onsemi.com/site/pdf/Patent-Marking.pdf). **onsemi** reserves the right to make changes at any time to any products or information herein, without notice. The information herein is provided "as-is" and **onsemi** makes no warranty, representation or guarantee regarding the accuracy of the information, product features, availability, functionality, or suitability of its products for any particular purpose, nor does **onsemi** assume any liability arising out of the application or use of any product or circuit, and specifically disclaims any and all liability, including without limitation special, consequential or incidental damages. Buyer is responsible for its products and applications using **onsemi** products, including compliance with all laws, regulations and safety requirements or standards, regardless of any support or applications information provided by **onsemi**. "Typical" parameters which may be provided in **onsemi** data sheets and/or specifications can and do vary in different applications and actual performance may vary over time. All operating parameters, including "Typicals" must be validated for each customer application by customer's technical experts. **onsemi** does not convey any license under any of its intellectual property rights nor the rights of others. **onsemi** products are not designed, intended, or authorized for use as a critical component in life support systems or any FDA Class 3 medical devices or medical devices with a same or similar classification in a foreign jurisdiction or any devices intended for implantation in the human body. Should Buyer purchase or use **onsemi** products for any such unintended or unauthorized application, Buyer shall indemnify and hold **onsemi** and its officers, employees, subsidiaries, affiliates, and distributors harmless against all claims, costs, damages, and expenses, and reasonable attorney fees arising out of, directly or indirectly, any claim of personal injury or death associated with such unintended or unauthorized use, even if such claim alleges that **onsemi** was negligent regarding the design or manufacture of the part. **onsemi** is an Equal Opportunity/Affirmative Action Employer. This literature is subject to all applicable copyright laws and is not for resale in any manner.

## ADDITIONAL INFORMATION

### TECHNICAL PUBLICATIONS:

Technical Library: [www.onsemi.com/design/resources/technical-documentation](http://www.onsemi.com/design/resources/technical-documentation)  
onsemi Website: [www.onsemi.com](http://www.onsemi.com)

### ONLINE SUPPORT: [www.onsemi.com/support](http://www.onsemi.com/support)

For additional information, please contact your local Sales Representative at [www.onsemi.com/support/sales](http://www.onsemi.com/support/sales)

## Looking for pricing, stock, or lifecycle information?

Click below to explore more details on WIN SOURCE:

 [View NB4L52MNG on WIN SOURCE](#)

 [ON Semiconductor](#) Information

## Optimize Your Supply Chain with WIN SOURCE Solutions

-  Global Sourcing Solution
-  Obsolete Management
-  Cost Control Management
-  Shortage Management
-  Alternative Solution
-  Excess Inventory Management