



**THE DATASHEET OF  
XC95288-15BG352I**





## XC95288 In-System Programmable CPLD

DS069 (v5.0) May 17, 2013

### Product Specification

### Features

- 15 ns pin-to-pin logic delays on all pins
- $f_{CNT}$  to 95 MHz
- 288 macrocells with 6,400 usable gates
- Up to 166 user I/O pins
- 5V in-system programmable
  - Endurance of 10,000 program/erase cycles
  - Program/erase over full commercial voltage and temperature range
- Enhanced pin-locking architecture
- Flexible 36V18 Function Block
  - 90 product terms drive any or all of 18 macrocells within Function Block
  - Global and product term clocks, output enables, set and reset signals
- Extensive IEEE Std 1149.1 boundary-scan (JTAG) support
- Programmable power reduction mode in each macrocell
- Slew rate control on individual outputs
- User programmable ground pin capability
- Extended pattern security features for design protection
- High-drive 24 mA outputs
- 3.3V or 5V I/O capability
- Advanced CMOS 5V FastFLASH™ technology
- Supports parallel programming of more than one XC9500 concurrently
- Available 352-pin BGA and 208-pin HQFP packages

### Description

The XC95288 is a high-performance CPLD providing advanced in-system programming and test capabilities for general purpose logic integration. It is comprised of eight 36V18 Function Blocks, providing 6,400 usable gates with propagation delays of 15 ns. See [Figure 2](#) for the architecture overview.

### Power Management

Power dissipation can be reduced in the XC95288 by configuring macrocells to standard or low-power modes of operation. Unused macrocells are turned off to minimize power dissipation.

Operating current for each design can be approximated for specific operating conditions using the following equation:

$$I_{CC} \text{ (mA)} = MC_{HP} (1.7) + MC_{LP} (0.9) + MC (0.006 \text{ mA/MHz}) f$$

Where:

$MC_{HP}$  = Macrocells in high-performance mode

$MC_{LP}$  = Macrocells in low-power mode

$MC$  = Total number of macrocells used

$f$  = Clock frequency (MHz)

[Figure 1](#) shows a typical calculation for the XC95288 device.

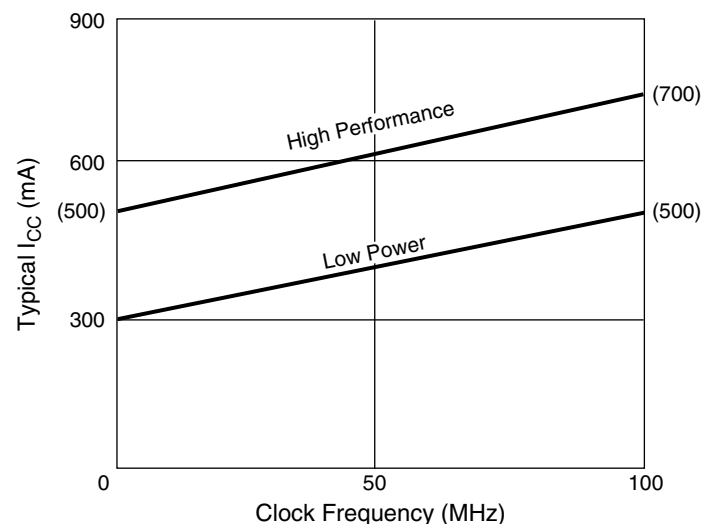

DS069\_01\_110101

Figure 1: Typical  $I_{CC}$  vs. Frequency for XC95288

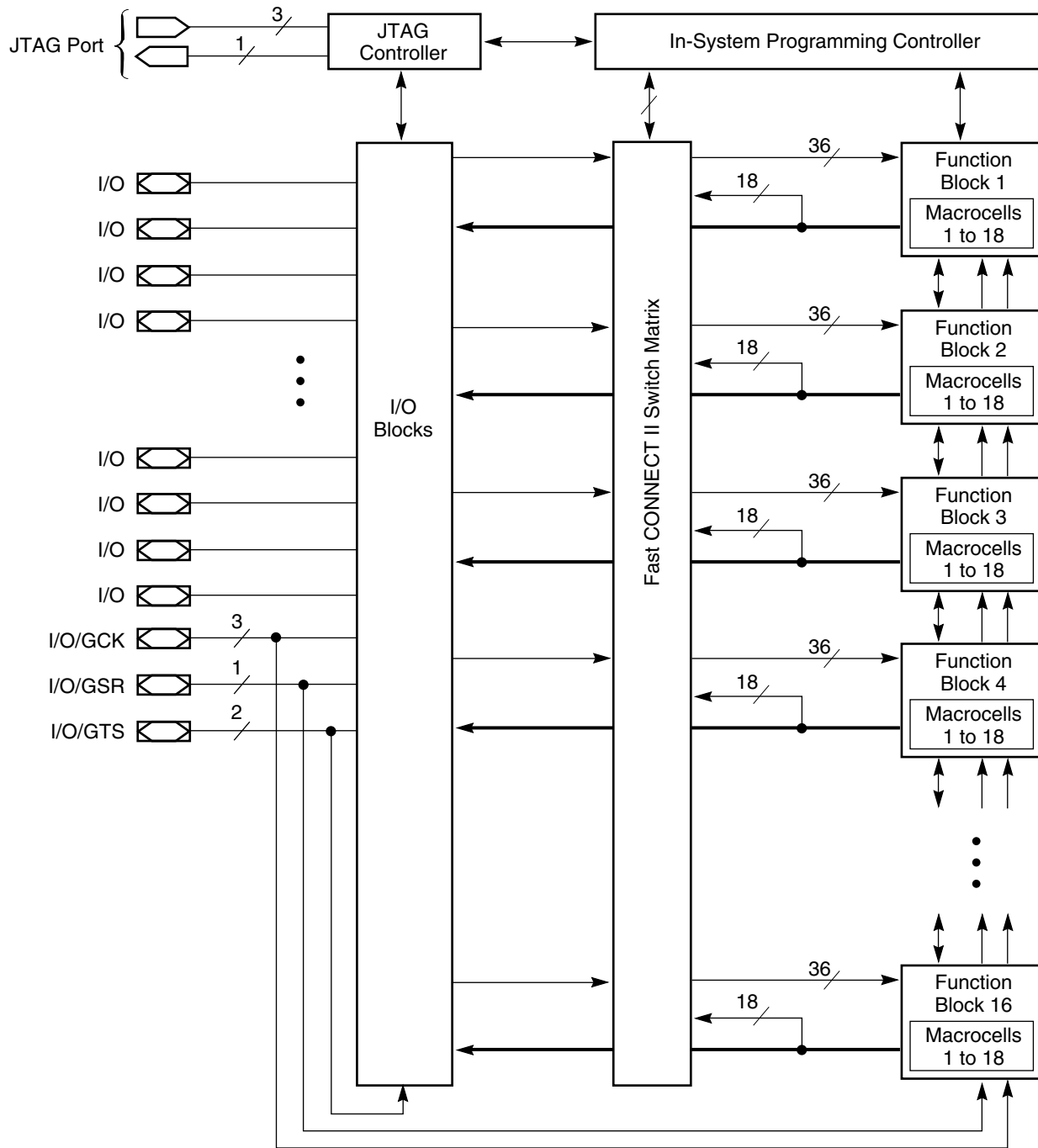

DS069\_02\_110101

Figure 2: XC95288 Architecture

Function block outputs (indicated by the bold line) drive the I/O blocks directly.

## Absolute Maximum Ratings

Symbol	Description	Value	Units
$V_{CC}$	Supply voltage relative to GND	-0.5 to 7.0	V
$V_{IN}$	Input voltage relative to GND	-0.5 to $V_{CC} + 0.5$	V
$V_{TS}$	Voltage applied to 3-state output	-0.5 to $V_{CC} + 0.5$	V
$T_{STG}$	Storage temperature (ambient)	-65 to +150	°C
$T_J$	Junction temperature	+150	°C

**Notes:**

- Stresses beyond those listed under Absolute Maximum Ratings may cause permanent damage to the device. These are stress ratings only, and functional operation of the device at these or any other conditions beyond those listed under Operating Conditions is not implied. Exposure to Absolute Maximum Ratings conditions for extended periods of time may affect device reliability.

## Recommended Operation Conditions

Symbol	Parameter		Min	Max	Units
$V_{CCINT}$	Supply voltage for internal logic and input buffers	Commercial $T_A = 0^\circ\text{C}$ to $70^\circ\text{C}$	4.75	5.25	V
		Industrial $T_A = -40^\circ\text{C}$ to $+85^\circ\text{C}$	4.5	5.5	
$V_{CCIO}$	Supply voltage for output drivers for 5V operation	Commercial $T_A = 0^\circ\text{C}$ to $70^\circ\text{C}$	4.75	5.25	V
		Industrial $T_A = -40^\circ\text{C}$ to $+85^\circ\text{C}$	4.5	5.5	
	Supply voltage for output drivers for 3.3V operation	3.0	3.6		
$V_{IL}$	Low-level input voltage		0	0.80	V
$V_{IH}$	High-level input voltage		2.0	$V_{CCINT} + 0.5$	V
$V_O$	Output voltage		0	$V_{CCIO}$	V

## Quality and Reliability Characteristics

Symbol	Parameter	Min	Max	Units
$T_{DR}$	Data Retention	20	-	Years
$N_{PE}$	Program/Erase Cycles (Endurance)	10,000	-	Cycles

## DC Characteristic Over Recommended Operating Conditions

Symbol	Parameter	Test Conditions	Min	Max	Units
$V_{OH}$	Output high voltage for 5V outputs	$I_{OH} = -4.0\text{ mA}$ , $V_{CC} = \text{Min}$	2.4	-	V
	Output high voltage for 3.3V outputs	$I_{OH} = -3.2\text{ mA}$ , $V_{CC} = \text{Min}$	2.4	-	V
$V_{OL}$	Output low voltage for 5V outputs	$I_{OL} = 24\text{ mA}$ , $V_{CC} = \text{Min}$	-	0.5	V
	Output low voltage for 3.3V outputs	$I_{OL} = 10\text{ mA}$ , $V_{CC} = \text{Min}$	-	0.4	V
$I_{IL}$	Input leakage current	$V_{CC} = \text{Max}$ $V_{IN} = \text{GND or } V_{CC}$	-	$\pm 10$	$\mu\text{A}$
$I_{IH}$	I/O high-Z leakage current	$V_{CC} = \text{Max}$ $V_{IN} = \text{GND or } V_{CC}$	-	$\pm 10$	$\mu\text{A}$
$C_{IN}$	I/O capacitance	$V_{IN} = \text{GND}$ $f = 1.0\text{ MHz}$	-	10	pF
$I_{CC}$	Operating supply current (low power mode, active)	$V_I = \text{GND}$ , No load $f = 1.0\text{ MHz}$	300 (Typical)		mA

AC Characteristics

Symbol	Parameter	XC95288-15		XC95288-20		Units
		Min	Max	Min	Max	
$T_{PD}$	I/O to output valid	-	15.0	-	20.0	ns
$T_{SU}$	I/O setup time before GCK	8.0	-	10.0	-	ns
$T_H$	I/O hold time after GCK	0	-	0	-	ns
$T_{CO}$	GCK to output valid	-	8.0	-	10.0	ns
$f_{CNT}^{(1)}$	16-bit counter frequency	95.2	-	83.3	-	MHz
$f_{SYSTEM}^{(2)}$	Multiple FB internal operating frequency	55.6	-	50.0	-	MHz
$T_{PSU}$	I/O setup time before p-term clock input	4.0	-	4.0	-	ns
$T_{PH}$	I/O hold time after p-term clock input	4.0	-	6.0	-	ns
$T_{PCO}$	P-term clock output valid	-	12.0	-	16.0	ns
$T_{OE}$	GTS to output valid	-	11.0	-	16.0	ns
$T_{OD}$	GTS to output disable	-	11.0	-	16.0	ns
$T_{POE}$	Product term OE to output enabled	-	14.0	-	18.0	ns
$T_{POD}$	Product term OE to output disabled	-	14.0	-	18.0	ns
$T_{WLH}$	GCK pulse width (High or Low)	5.5	-	5.5	-	ns
$T_{APRPW}$	Asynchronous preset/reset pulse width (High or Low)	8.0	-	8.0	-	ns

Notes:

- $f_{CNT}$  is the fastest 16-bit counter frequency available, using the local feedback when applicable.  $f_{CNT}$  is also the Export Control Maximum flip-flop toggle rate,  $f_{TOG}$ .
- $f_{SYSTEM}$  is the internal operating frequency for general purpose system designs spanning multiple FBs.



Output Type	VCCIO	VTEST	R1	R2	CL
	5.0V	5.0V	160Ω	120Ω	35 pF
	3.3V	3.3V	260Ω	360Ω	35 pF

DS067\_03\_110101

Figure 3: AC Load Circuit

## Internal Timing Parameters

Symbol	Parameter	XC95288-15		XC95288-20		Units
		Min	Max	Min	Max	
<b>Buffer Delays</b>						
$T_{IN}$	Input buffer delay	-	4.5	-	6.5	ns
$T_{GCK}$	GCK buffer delay	-	3.0	-	3.0	ns
$T_{GSR}$	GSR buffer delay	-	7.5	-	9.5	ns
$T_{GTS}$	GTS buffer delay	-	11.0	-	16.0	ns
$T_{OUT}$	Output buffer delay	-	4.5	-	6.5	ns
$T_{EN}$	Output buffer enable/disable delay	-	0	-	0	ns
<b>Product Term Control Delays</b>						
$T_{PTCK}$	Product term clock delay	-	2.5	-	2.5	ns
$T_{PTSR}$	Product term set/reset delay	-	3.0	-	3.0	ns
$T_{PTTS}$	Product term 3-state delay	-	5.0	-	5.0	ns
<b>Internal Register and Combinatorial Delays</b>						
$T_{PDI}$	Combinatorial logic propagation delay	-	3.0	-	4.0	ns
$T_{SUI}$	Register setup time	3.5	-	3.5	-	ns
$T_{HI}$	Register hold time	4.5	-	6.5	-	ns
$T_{COI}$	Register clock to output valid time	-	0.5	-	0.5	ns
$T_{AOI}$	Register async. S/R to output delay	-	8.0	-	8.0	ns
$T_{RAI}$	Register async. S/R recover before clock	10.0	-	10.0	-	ns
$T_{LOGI}$	Internal logic delay	-	3.0	-	3.0	ns
$T_{LOGILP}$	Internal low power logic delay	-	11.5	-	11.5	ns
<b>Feedback Delays</b>						
$T_F$	FastCONNECT feedback delay	-	11.0	-	13.0	ns
$T_{LF}$	Function block local feedback delay	-	3.5	-	5.0	ns
<b>Time Adders</b>						
$T_{PTA}^{(1)}$	Incremental product term allocator delay	-	1.0	-	1.5	ns
$T_{SLEW}$	Slew-rate limited delay	-	5.0	-	5.5	ns

**Notes:**

- $T_{PTA}$  is multiplied by the span of the function as defined in the XC9500 family data sheet.

**XC95288 I/O Pins**

Function Block	Macrocell	HQ208	BG352	BScan Order
1	1	–	–	861
1	2	28	N26	858
1	3	29	P25	855
1	4	–	–	852
1	5	30	P23	849
1	6	31	P24	846
1	7	–	–	843
1	8	32	R26	840
1	9	–	R25	837
1	10	33	R24	834
1	11	–	R23	831
1	12	34	T26	828
1	13	–	–	825
1	14	35	T25	822
1	15	36	T23	819
1	16	–	–	816
1	17	37	V26	813
1	18	–	–	810
2	1	–	–	807
2	2	15	K23	804
2	3	16	K24	801
2	4	–	–	798
2	5	17	J25	795
2	6	18	L24	792
2	7	–	–	789
2	8	19	K25	786
2	9	–	L25	783
2	10	20	L26	780
2	11	–	M23	777
2	12	21	M24	774
2	13	–	–	771
2	14	22	M25	768
2	15	23	M26	765
2	16	–	–	762
2	17	25	N25	759
2	18	–	–	756

Function Block	Macrocell	HQ208	BG352	BScan Order
3	1	–	–	753
3	2	38	U24	750
3	3	39	U23	747
3	4	–	–	744
3	5	40	Y26	741
3	6	41	W25	738
3	7	–	–	735
3	8	43	AA26	732
3	9	–	Y25	729
3	10	44 <sup>[1]</sup>	Y24 <sup>[1]</sup>	726 <sup>[1]</sup>
3	11	–	AA25	723
3	12	45	AB25	720
3	13	–	–	717
3	14 <sup>[1]</sup>	46 <sup>[1]</sup>	AA24 <sup>[1]</sup>	714
3	15	47	Y23	711
3	16	–	–	708
3	17	48	AC26	705
3	18	–	–	702
4	1	–	–	699
4	2 <sup>[1]</sup>	3 <sup>[1]</sup>	E23 <sup>[1]</sup>	696
4	3	4	C26	693
4	4	–	–	690
4	5 <sup>[1]</sup>	5 <sup>[1]</sup>	E24 <sup>[1]</sup>	687
4	6	6	F24	684
4	7	–	–	681
4	8 <sup>[1]</sup>	7 <sup>[1]</sup>	E25 <sup>[1]</sup>	678
4	9	–	D26	675
4	10	8	G24	672
4	11	–	F25	669
4	12 <sup>[1]</sup>	9 <sup>[1]</sup>	F26 <sup>[1]</sup>	666
4	13	–	–	663
4	14	10	H23	660
4	15	12	G26	657
4	16	–	–	654
4	17	14	H25	651
4	18	–	–	648

**Notes:**

1. Global control pin.

**XC95288 I/O Pins (Continued)**

Function Block	Macrocell	HQ208	BG352	BScan Order
5	1	–	–	645
5	2	49	AA23	642
5	3	50	AB24	639
5	4	–	–	636
5	5	51	AD25	633
5	6	54	AE24	630
5	7	–	–	627
5	8 <sup>[1]</sup>	55 <sup>[1]</sup>	AD23 <sup>[1]</sup>	624
5	9	–	AC22	621
5	10	56	AF24	618
5	11	–	AD22	615
5	12	57	AE23	612
5	13	–	–	609
5	14	58	AE22	606
5	15	60	AE21	603
5	16	–	–	600
5	17	61	AF21	597
5	18	–	–	594
6	1	–	–	591
6	2	197	C19	588
6	3	198	D18	585
6	4	–	–	582
6	5	199	A21	579
6	6	200	B20	576
6	7	–	–	573
6	8	201	C20	570
6	9	–	B21	567
6	10	202	B22	564
6	11	–	C21	561
6	12	203	D20	558
6	13	–	–	555
6	14	205	B24	552
6	15 <sup>[1]</sup>	206 <sup>[1]</sup>	C23 <sup>[1]</sup>	549
6	16	–	–	546
6	17	208	D22	543
6	18	–	–	540

Function Block	Macrocell	HQ208	BG352	BScan Order
7	1	–	–	537
7	2	62	AC19	534
7	3	63	AD19	531
7	4	–	–	528
7	5	64	AE20	525
7	6	66	AC18	522
7	7	–	–	519
7	8	67	AD18	516
7	9	–	AE19	513
7	10	69	AD17	510
7	11	–	AE18	507
7	12	70	AF18	504
7	13	–	–	501
7	14	71	AE17	498
7	15	72	AE16	495
7	16	–	–	492
7	17	73	AF16	489
7	18	–	–	486
8	1	–	–	483
8	2	186	A15	480
8	3	187	B15	477
8	4	–	–	474
8	5	188	C15	471
8	6	189	D15	468
8	7	–	–	465
8	8	191	A16	462
8	9	–	B16	459
8	10	192	C16	456
8	11	–	B17	453
8	12	193	C17	450
8	13	–	–	447
8	14	194	B18	444
8	15	195	A20	441
8	16	–	–	438
8	17	196	B19	435
8	18	–	–	432

**Notes:**

1. Global control pin.

**XC95288 I/O Pins (Continued)**

Function Block	Macrocell	HQ208	BG352	BScan Order
9	1	–	–	429
9	2	74	AE14	426
9	3	75	AF14	423
9	4	–	–	420
9	5	76	AE13	417
9	6	77	AC13	414
9	7	–	–	411
9	8	78	AD13	408
9	9	–	AF12	405
9	10	80	AE12	402
9	11	82	AD12	399
9	12	83	AC12	396
9	13	–	–	393
9	14	84	AF11	390
9	15	85	AE11	387
9	16	–	–	384
9	17	86	AE9	381
9	18	–	–	378
10	1	–	–	375
10	2	170	C10	372
10	3	171	B9	369
10	4	–	–	366
10	5	173	A9	363
10	6	174	D11	360
10	7	–	–	357
10	8	175	B11	354
10	9	–	A11	351
10	10	178	C12	348
10	11	179	B12	345
10	12	180	A12	342
10	13	–	–	339
10	14	182	A13	336
10	15	183	B14	333
10	16	–	–	330
10	17	185	C14	327
10	18	–	–	324

Function Block	Macrocell	HQ208	BG352	BScan Order
11	1	–	–	321
11	2	87	AD9	318
11	3	88	AC10	315
11	4	–	–	312
11	5	89	AF7	309
11	6	90	AE8	306
11	7	–	–	303
11	8	91	AD8	300
11	9	–	AE7	297
11	10	95	AD7	294
11	11	97	AE5	291
11	12	99	AC7	288
11	13	–	–	285
11	14	100	AE3	282
11	15	101	AD4	279
11	16	–	–	276
11	17	102	AC5	273
11	18	–	–	270
12	1	–	–	267
12	2	158	B3	264
12	3	159	A3	261
12	4	–	–	258
12	5	160	D6	255
12	6	161	C6	252
12	7	–	–	249
12	8	162	B5	246
12	9	–	A4	243
12	10	164	B6	240
12	11	165	A6	237
12	12	166	D8	234
12	13	–	–	231
12	14	167	B7	228
12	15	168	A7	225
12	16	–	–	222
12	17	169	D9	219
12	18	–	–	216

**XC95288 I/O Pins (Continued)**

Function Block	Macrocell	HQ208	BG352	BScan Order
13	1	–	–	213
13	2	103	AD3	210
13	3	106	AD2	207
13	4	–	–	204
13	5	107	AC3	201
13	6	109	AD1	198
13	7	–	–	195
13	8	110	AA4	192
13	9	–	AA3	189
13	10	111	AB2	186
13	11	112	AC1	183
13	12	113	AA2	180
13	13	–	–	177
13	14	114	AA1	174
13	15	115	Y1	171
13	16	–	–	168
13	17	116	V4	165
13	18	–	–	162
14	1	–	–	159
14	2	144	K3	156
14	3	145	G1	153
14	4	–	–	150
14	5	146	H2	147
14	6	147	H3	144
14	7	–	–	141
14	8	148	J4	138
14	9	–	F1	135
14	10	149	G2	132
14	11	150	G3	129
14	12	151	F2	126
14	13	–	–	123
14	14	152	E2	120
14	15	154	D2	117
14	16	–	–	114
14	17	155	F4	111
14	18	–	–	108

Function Block	Macrocell	HQ208	BG352	BScan Order
15	1	–	–	105
15	2	117	V3	102
15	3	118	W2	99
15	4	–	–	96
15	5	119	U4	93
15	6	120	U3	90
15	7	–	–	87
15	8	121	V2	84
15	9	–	V1	81
15	10	122	U2	78
15	11	123	T2	75
15	12	125	R4	72
15	13	–	–	69
15	14	126	R3	66
15	15	127	R2	63
15	16	–	–	60
15	17	128	R1	57
15	18	–	–	54
16	1	–	–	51
16	2	131	P1	48
16	3	133	N2	45
16	4	–	–	42
16	5	134	N4	39
16	6	135	N3	36
16	7	–	–	33
16	8	136	M1	30
16	9	–	M2	27
16	10	137	M3	24
16	11	138	M4	21
16	12	139	L1	18
16	13	–	–	15
16	14	140	L2	12
16	15	142	L3	9
16	16	–	–	6
16	17	143	J1	3
16	18	–	–	0

**XC95288 Global, JTAG, and Power Pins**

Pin Type	HQ208	BG352
I/O/GCK1	44	Y24
I/O/GCK2	46	AA24
I/O/GCK3	55	AD23
I/O/GTS1	7	E25
I/O/GTS2	9	F26
I/O/GTS3	3	E23
I/O/GTS4	5	E24
I/O/GSR	206	C23
TCK	98	AD6
TDI	94	AF6
TDO	176	D12
TMS	96	AE6
V <sub>CCINT</sub> 5V	11, 59, 124, 153, 204	J23, V24, AF23, AC15, AF15, AD11, AD5, Y3, T1, J3, G4, D5, D10, B13, D17, C22, H24
V <sub>CCIO</sub> 3.3V/5V	1, 26, 53, 65, 79, 92, 105, 132, 157, 172, 181, 184	A10, A17, B2, B25, D7, D13, D19, G23, H4, K1, K26, N23, P4, U1, U26, W23, Y4, AC8, AC14, AC20, AE25, AF10, AF17
GND	2, 13, 24, 27, 42, 52, 68, 81, 93, 104, 108, 129, 130, 141, 156, 163, 177, 190, 207	A1, A2, A5, A8, A14, A19, A22, A25, A26, B1, B26, C7, C9, C13, C18, D24, E1, E26, H1, H26, K4, N1, N24, P3, P26, V23, W1, W4, W26, AB1, AB4, AB26, AC9, AD10, AD14, AD15, AD20, AE1, AE26, AF1, AF2, AF5, AF8, AF13, AF19, AF22, AF25, AF26
No Connects	-	A18, A23, A24, B4, B8, B10, B23, C1, C2, C3, C4, C5, C8, C11, C24, C25, D1, D3, D4, D14, D16, D21, D23, D25, E3, E4, F3, F23, G25, J2, J24, J26, K2, L4, L23, P2, T3, T4, T24, U25, V25, W3, W24, Y2, AB3, AB23, AC2, AC4, AC6, AC11, AC16, AC17, AC21, AC23, AC24, AC25, AD16, AD21, AD24, AD26, AE2, AE4, AE10, AE15, AF3, AF4, AF9, AF20

## Device Part Marking and Ordering Combination Information

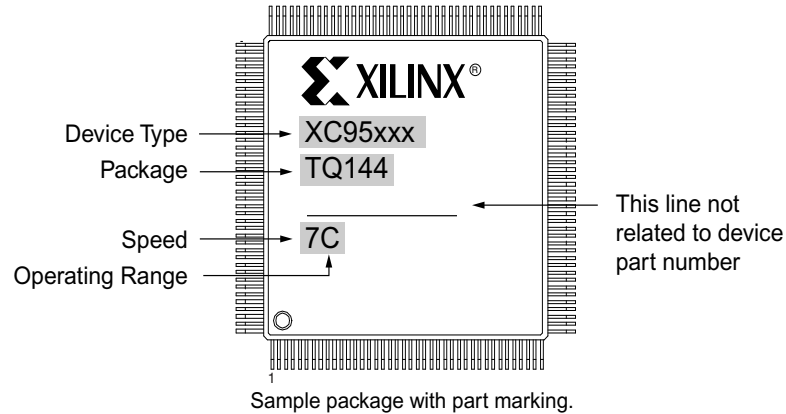

Device Ordering and Part Marking Number	Speed (pin-to-pin delay)	Pkg. Symbol	No. of Pins	Package Type	Operating Range <sup>(1)</sup>
XC95288-10HQ208C	10 ns	HQ208	208-pin	Heat Sink Quad Flat Pack (HQFP)	C
XC95288-10BG352C	10 ns	BG352	352-ball	Ball Grid Array (BGA)	C
XC95288-15HQ208C	15 ns	HQ208	208-pin	Heat Sink Quad Flat Pack (HQFP)	C
XC95288-15BG352C	15 ns	BG352	352-ball	Ball Grid Array (BGA)	C
XC95288-15HQ208I	15 ns	HQ208	208-pin	Heat Sink Quad Flat Pack (HQFP)	I
XC95288-15BG352I	15 ns	BG352	352-ball	Ball Grid Array (BGA)	I
XC95288-20HQ208C	20 ns	HQ208	208-pin	Heat Sink Quad Flat Pack (HQFP)	C
XC95288-20BG352C	20 ns	BG352	352-ball	Ball Grid Array (BGA)	C
XC95288-20HQ208I	20 ns	HQ208	208-pin	Heat Sink Quad Flat Pack (HQFP)	I
XC95288-20BG352I	20 ns	BG352	352-ball	Ball Grid Array (BGA)	I

**Notes:**

1. C = Commercial:  $T_A = 0^\circ$  to  $+70^\circ\text{C}$ ; I = Industrial:  $T_A = -40^\circ$  to  $+85^\circ\text{C}$

## Warranty Disclaimer

THESE PRODUCTS ARE SUBJECT TO THE TERMS OF THE XILINX LIMITED WARRANTY WHICH CAN BE VIEWED AT <http://www.xilinx.com/warranty.htm>. THIS LIMITED WARRANTY DOES NOT EXTEND TO ANY USE OF THE PRODUCTS IN AN APPLICATION OR ENVIRONMENT THAT IS NOT WITHIN THE SPECIFICATIONS STATED ON THE THEN-CURRENT XILINX DATA SHEET FOR THE PRODUCTS. PRODUCTS ARE NOT DESIGNED TO BE FAIL-SAFE AND ARE NOT WARRANTED FOR USE IN APPLICATIONS THAT POSE A RISK OF PHYSICAL HARM OR LOSS OF LIFE. USE OF PRODUCTS IN SUCH APPLICATIONS IS FULLY AT THE RISK OF CUSTOMER SUBJECT TO APPLICABLE LAWS AND REGULATIONS.

## Revision History

The following table shows the revision history for this document.

Date	Version	Revision
12/04/1998	3.1	Update AC characteristics and internal parameters.
06/18/2003	4.0	Updated format.
08/21/2003	4.1	Updated Package Device Marking Pin 1 orientation.

Date	Version	Revision
04/15/2005	4.2	Added asynchronous preset/reset pulse width specification ( $T_{APRPW}$ ).
04/03/2006	4.3	Added Warranty Disclaimer.
05/17/2013	5.0	The products listed in this data sheet are obsolete. See <a href="#">XCN11010</a> for further information.

## Looking for pricing, stock, or lifecycle information?

Click below to explore more details on WIN SOURCE:

 [View XC95288-15BG352I on WIN SOURCE](#)

 [Xilinx Inc. Information](#)

## Optimize Your Supply Chain with WIN SOURCE Solutions

-  Global Sourcing Solution
-  Obsolete Management
-  Cost Control Management
-  Shortage Management
-  Alternative Solution
-  Excess Inventory Management