



**THE DATASHEET OF  
TMS470R1A288PGEA**



## FEATURES

- High-Performance Static CMOS Technology
- TMS470R1x 16/32-Bit RISC Core (ARM7TDMI™)
  - 24-MHz System Clock (48-MHz Pipeline)
  - Independent 16/32-Bit Instruction Set
  - Open Architecture With Third-Party Support
  - Built-In Debug Module
- Integrated Memory
  - 288K-Byte Program Flash
    - Two Banks With 8 Contiguous Sectors
  - 16K-Byte Static RAM (SRAM)
  - Memory Security Module (MSM)
  - JTAG Security Module
- Operating Features
  - Low-Power Modes: STANDBY and HALT
  - Extended Industrial Temperature Range
- 470+ System Module
  - 32-Bit Address Space Decoding
  - Bus Supervision for Memory/Peripherals
  - Digital Watchdog (DWD) Timer
  - Analog Watchdog (AWD) Timer
  - Enhanced Real-Time Interrupt (RTI)
  - Interrupt Expansion Module (IEM)
  - System Integrity and Failure Detection
  - ICE Breaker
- Direct Memory Access (DMA) Controller
  - 32 Control Packets and 16 Channels
- Zero-Pin Phase-Locked Loop (ZPLL)-Based Clock Module With Prescaler
  - Multiply-by-8 Internal ZPLL Option
  - ZPLL Bypass Mode
- High-End Timer Lite (HET)
  - 12 Programmable I/O Channels:
    - 12 High-Resolution Pins
  - High-Resolution Share Feature (XOR)
  - High-End Timer RAM
    - 64-Instruction Capacity
- External Clock Prescale (ECP) Module
  - Programmable Low-Frequency External Clock (CLK)
- Ten Communication Interfaces:
  - Two Serial Peripheral Interfaces (SPIs)
    - 255 Programmable Baud Rates
  - Two Serial Communication Interfaces (SCIs)
    - 2<sup>24</sup> Selectable Baud Rates
    - Asynchronous/Isosynchronous Modes
  - Class II Serial Interface B (C2S1b)
    - Normal 10.4 Kbps and 4X Mode 41.6 Kbps
  - Two Standard CAN Controllers (SCC)
    - 16-Mailbox Capacity
    - Fully Compliant With CAN Protocol, Version 2.0B
  - Three Inter-Integrated Circuit (I2C) Modules
    - Multi-Master and Slave Interfaces
    - Up to 400 Kbps (Fast Mode)
    - 7- and 10-Bit Address Capability
- 12-Channel 10-Bit Multi-Buffered ADC (MibADC)
  - 64-Word FIFO Buffer
  - Single- or Continuous-Conversion Modes
  - 1.55 μs Minimum Sample/Conversion Time
  - Calibration Mode and Self-Test Features
- Flexible Interrupt Handling
- Expansion Bus Module (EBM) (PGE only)
  - Supports 8- and 16-Bit Expansion Bus Memory Interface Mappings
  - 42 I/O Expansion Bus Pins
- 50 Dedicated General-Purpose I/O (GIO) Pins and 43 Additional Peripheral I/Os (PGE)
- 14 Dedicated General-Purpose I/O (GIO) Pins and 43 Additional Peripheral I/Os (PZ)
- 16 External Interrupts
- On-Chip Scan-Base Emulation Logic, IEEE Standard 1149.1<sup>(1)</sup> (JTAG) Test-Access Port
- 144-Pin Plastic Low-Profile Quad Flatpack (PGE Suffix)
- 100-Pin Plastic Low-Profile Quad Flatpack (PZ Suffix)

<sup>(1)</sup> The test-access port is compatible with the IEEE Standard 1149.1-1990, IEEE Standard Test-Access Port and Boundary Scan Architecture specification. Boundary scan is not supported on this device.



Please be aware that an important notice concerning availability, standard warranty, and use in critical applications of Texas Instruments semiconductor products and disclaimers thereto appears at the end of this data sheet.

ARM7TDMI is a trademark of Advanced RISC Machines Limited (ARM).  
All other trademarks are the property of their respective owners.

# TMS470R1A288

## 16/32-Bit RISC Flash Microcontroller

SPNS106B—SEPTEMBER 2005—REVISED AUGUST 2006

### TMS470R1A288 144-Pin PGE Package (Top View) (without Expansion Bus)

Pin	Signal	Pin	Signal
108	ADIN[5]	72	HET[1]
107	ADIN[6]	71	HET[2]
106	ADIN[7]	70	GIOE[6]
105	ADIN[8]	69	VCCIO
104	ADIN[9]	68	VSSIO
103	ADIN[10]	67	GIOE[5]
102	ADIN[11]	66	HET[3]
101	ADEVT	65	HET[4]
100	GIOF[7]	64	GIOE[4]
99	GIOF[6]	63	HET[5]
98	GIOA[5]/INT[5]	62	SPI2SCS
97	PLLDIS	61	GIOE[3]
96	GIOF[5]	60	SPI2ENA
95	I2C2SCL	59	SPI2SIMO
94	I2C2SDA	58	GIOE[2]
93	GIOF[4]	57	SPI2SOMI
92	VCC	56	SPI2CLK
91	VSS	55	CAN2STX
90	GIOF[3]	54	CAN2SRX
89	GIOF[2]	53	VCC
88	I2C1SCL	52	VSS
87	I2C1SDA	51	SCI2CLK
86	VCCIO	50	SCI2RX
85	VSSIO	49	SCI2TX
84	CAN1STX	48	SCI1CLK
83	CAN1SRX	47	GIOE[1]
82	GIOF[1]	46	SCI1RX
81	CLKOUT	45	SCI1TX
80	GIOF[0]	44	GIOE[0]
79	GIOA[7]/INT[7]	43	GIOB[0]
78	GIOA[6]/INT[6]	42	GIOD[0]
77	GIOE[7]	41	GIOH[1]/INT[9]
76	TCK	40	GIOH[2]/INT[10]
75	TDO	39	GIOD[1]
74	TDI	38	GIOH[3]/INT[11]
73	HET[0]	37	GIOH[4]/INT[12]
109	ADREFHI		
110	ADREFLO		
111	VCCAD		
112	VSSAD		
113	ADIN[4]		
114	ADIN[3]		
115	ADIN[2]		
116	ADIN[1]		
117	ADIN[0]		
118	PORRST		
119	GIOC[4]		
120	GIOC[3]		
121	RST		
122	VSS		
123	VCC		
124	TEST		
125	GIOH[5]/INT[13]		
126	GIOC[2]		
127	GIOA[4]/INT[4]		
128	GIOC[1]		
129	VSS		
130	VCC		
131	VCCP		
132	FLTP2		
133	GIOA[3]/INT[3]		
134	GIOA[2]/INT[2]		
135	GIOC[0]		
136	GIOA[1]/INT[1]/ECLK		
137	VCCIO		
138	VSSIO		
139	GIOH[0]/INT[8]		
140	GIOG[7]		
141	GIOA[0]/INT[0]		
142	GIOG[6]		
143	GIOG[5]		
144	TRST		
1	SPI1SCS		
2	SPI1ENA		
3	GIOG[4]		
4	SPI1CLK		
5	SPI1SIMO		
6	GIOG[3]		
7	SPI1SOMI		
8	GIOG[2]		
9	HET[6]		
10	GIOG[1]		
11	HET[7]		
12	HET[8]		
13	VCC		
14	VSS		
15	HET[18]		
16	TMS2		
17	TMS		
18	HET[20]		
19	HET[22]		
20	GIOG[0]		
21	C2SILPN		
22	C2SIRX		
23	GIOD[5]		
24	C2SITX		
25	VCCIO		
26	VSSIO		
27	GIOD[4]		
28	I2C3SCL		
29	I2C3SDA		
30	GIOD[3]		
31	VCC		
32	OSCOU		
33	OSCI		
34	VSS		
35	GIOD[2]		
36	AWD		



# TMS470R1A288

## 16/32-Bit RISC Flash Microcontroller

SPNS106B—SEPTEMBER 2005—REVISED AUGUST 2006

TMS470R1A288 100-Pin PZ Package (Top View)

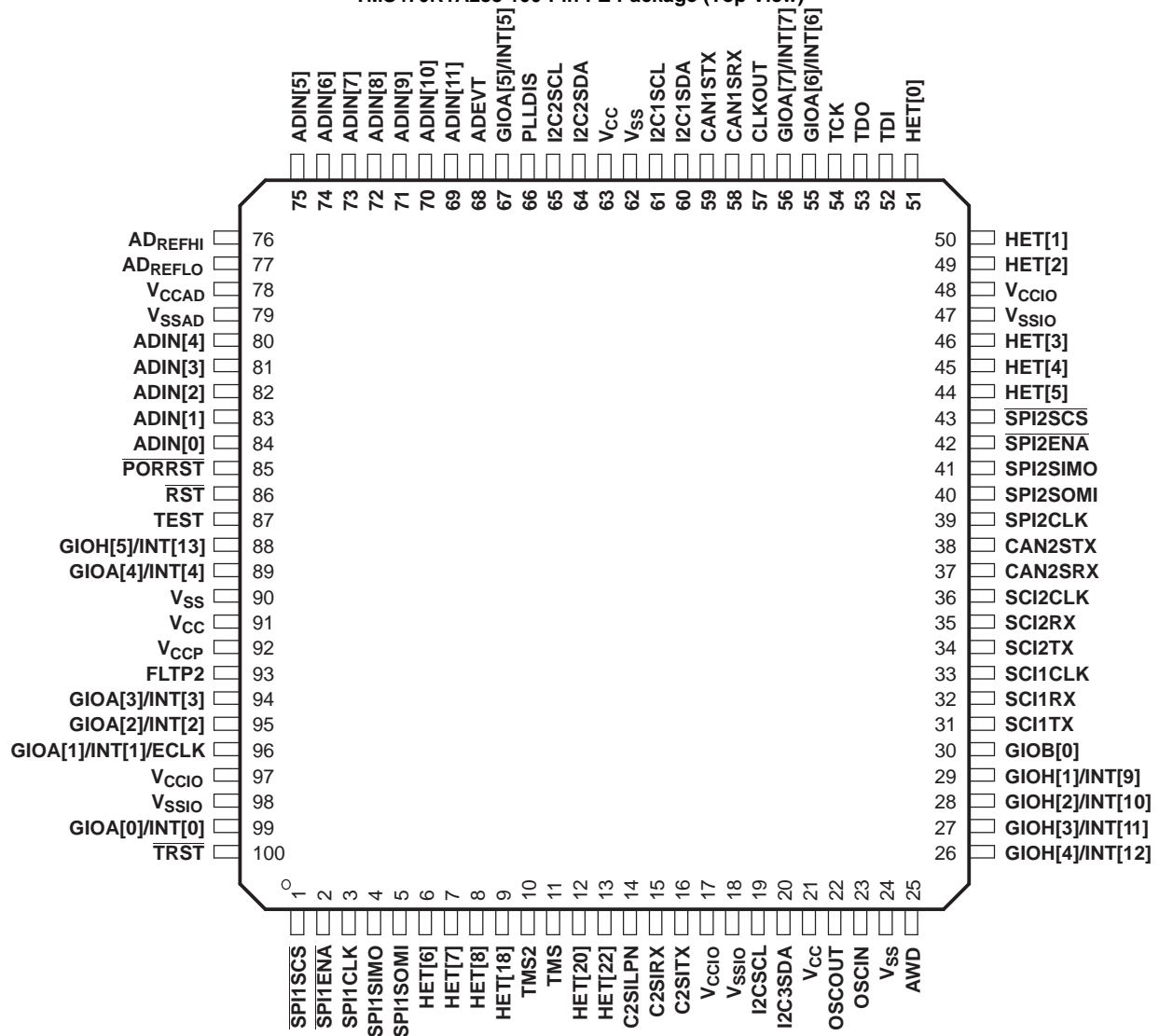

## DESCRIPTION

The TMS470R1A288<sup>(1)</sup> devices are members of the Texas Instruments TMS470R1x family of general-purpose 16/32-bit reduced instruction set computer (RISC) microcontrollers. The A288 microcontroller offers high performance utilizing the high-speed ARM7TDMI 16/32-bit RISC central processing unit (CPU), resulting in a high instruction throughput while maintaining greater code efficiency. The ARM7TDMI 16/32-bit RISC CPU views memory as a linear collection of bytes numbered upwards from zero. The A288 utilizes the big-endian format where the most significant byte of a word is stored at the lowest-numbered byte and the least significant byte at the highest numbered byte.

High-end embedded control applications demand more performance from their controllers while maintaining low costs. The A288 RISC core architecture offers solutions to these performance and cost demands while maintaining low power consumption.

The A288 devices contain the following:

- ARM7TDMI 16/32-Bit RISC CPU
- TMS470R1x system module (SYS) with 470+ enhancements
- 288K-byte flash
- 16K-byte SRAM
- Zero-pin phase-locked loop (ZPLL) clock module
- Digital watchdog (DWD) timer
- Analog watchdog (AWD) timer
- Enhanced real-time interrupt (RTI) module
- Interrupt expansion module (IEM)
- Memory security module (MSM)
- JTAG security module (JSM)
- Two serial peripheral interface (SPI) modules
- Two serial communications interface (SCI) modules
- Two standard CAN controllers (SCC)
- Three inter-integrated circuit (I2C) modules
- Class II serial interface B (C2SIb) module
- 10-bit multi-buffered analog-to-digital converter (MibADC), with 12 input channels
- High-end timer lite (HET) controlling 12 I/Os
- External clock prescale (ECP)
- Expansion bus module (EBM)
- Up to 93 I/O pins (PGE only), up to 57 I/O (PZ only)

The functions performed by the 470+ system module (SYS) include:

- Address decoding
- Memory protection
- Memory and peripherals bus supervision
- Reset and abort exception management
- Prioritization for all internal interrupt sources
- Device clock control
- Parallel signature analysis (PSA)

The enhanced real-time interrupt (RTI) module on the A288 has the option to be driven by the oscillator clock. The digital watchdog (DWD) is a 25-bit resettable decrementing counter that provides a system reset when the watchdog counter expires. This data sheet includes device-specific information such as memory and peripheral select assignment, interrupt priority, and a device memory map. For a more detailed functional description of the SYS module, see the *TMS470R1x System Module Reference Guide* (literature number SPNU189).

The A288 memory includes general-purpose SRAM supporting single-cycle read/write accesses in byte, half-word, and word modes.

(1) Throughout the remainder of this document, the TMS470R1A288 will be referred to as either the full device name or as A288.

# TMS470R1A288

## 16/32-Bit RISC Flash Microcontroller

SPNS106B–SEPTEMBER 2005–REVISED AUGUST 2006

---

The flash memory on this device is a nonvolatile, electrically erasable and programmable memory implemented with a 32-bit-wide data bus interface. When in pipeline mode, the flash operates with a system clock frequency of up to 48 MHz. The flash operates with a system clock frequency of up to 24 MHz. For more detailed information on the flash, see the *Flash* section of this data sheet and the *TMS470R1x F05 Flash Reference Guide* (literature number SPNU213).

The memory security module (MSM) and JTAG security module (JSM) prevent unauthorized access and visibility to on-chip memory, thereby preventing reverse engineering or manipulation of proprietary code. For more information, see the *TMS470R1x Memory Security Module Reference Guide* (literature number SPNU246) and the *TMS470R1x JTAG Security Module Reference Guide* (literature number SPNU245).

The A288 device has ten communication interfaces: two SPIs, two SCIs, two SCCs, a C2SI, and three I2Cs. The SPI provides a convenient method of serial interaction for high-speed communications between similar shift-register type devices. The SCI is a full-duplex, serial I/O interface intended for asynchronous communication between the CPU and other peripherals using the standard non-return-to-zero (NRZ) format. The SCC uses a serial, multimaster communication protocol that efficiently supports distributed real-time control with robust communication rates of up to 1 megabit per second (Mbps). The SCC is ideal for applications operating in noisy and harsh environments (e.g., industrial fields) that require reliable serial communication or multiplexed wiring. The C2SIb allows the A288 to transmit and receive messages on a class II network following an SAE J1850<sup>(2)</sup> standard. The I2C module is a multi-master communication module providing an interface between the A288 microcontroller and an I2C-compatible device via the I2C serial bus. The I2C supports both 100 Kbps and 400 Kbps speeds. For more detailed functional information on the SPI, SCI, and CAN peripherals, see the specific reference guides (literature numbers SPNU195, SPNU196, and SPNU197). For more detailed functional information on the I2C, see the *TMS470R1x Inter-Integrated Circuit (I2C) Reference Guide* (literature number SPNU223). For more detailed functional information on the C2SI, see the *TMS470R1x Class II Serial Interface B (C2SIb) Reference Guide* (literature number SPNU214).

The HET is an advanced intelligent timer that provides sophisticated timing functions for real-time applications. The timer is software-controlled, using a reduced instruction set, with a specialized timer micromachine and an attached I/O port. The HET can be used for compare, capture, or general-purpose I/O. It is especially well suited for applications requiring multiple sensor information and drive actuators with complex and accurate time pulses. The HET used in this device is the high-end timer lite. It has fewer I/Os than the usual 32 in a standard HET. For more detailed functional information on the HET, see the *TMS470R1x High-End Timer (HET) Reference Guide* (literature number SPNU199).

The A288HET peripheral contains the XOR-share feature. This feature allows two adjacent HET high-resolution channels to be XORed together, making it possible to output smaller pulses than a standard HET. For more detailed information on the HET XOR-share feature, see the *TMS470R1x High-End Timer (HET) Reference Guide* (literature number SPNU199).

The A288 device has one 10-bit-resolution, sample-and-hold MibADC. Each of the MibADC channels can be converted individually or can be grouped by software for sequential conversion sequences. There are three separate groupings, two of which can be triggered by an external event. Each sequence can be converted once when triggered or configured for continuous conversion mode. For more detailed functional information on the MibADC, see the *TMS470R1x Multi-Buffered Analog-to-Digital Converter (MibADC) Reference Guide* (literature number SPNU206).

The zero-pin phase-locked loop (ZPLL) clock module contains a phase-locked loop, a clock-monitor circuit, a clock-enable circuit, and a prescaler (with prescale values of 1–8). The function of the ZPLL is to multiply the external frequency reference to a higher frequency for internal use. The ZPLL provides ACLK to the system (SYS) module. The SYS module subsequently provides system clock (SYSCLK), real-time interrupt clock (RTICK), CPU clock (MCLK), and peripheral interface clock (ICLK) to all other A288 device modules. For more detailed functional information on the ZPLL, see the *TMS470R1x Zero-Pin Phase-Locked Loop (ZPLL) Clock Module Reference Guide* (literature number SPNU212).

### NOTE:

ACLK should not be confused with the MibADC internal clock, ADCLK. ACLK is the continuous system clock from an external resonator/crystal reference.

---

(2) SAE Standard J1850 Class B Data Communication Network Interface

The expansion bus module (EBM) is a standalone module that supports the multiplexing of the GIO functions and the expansion bus interface. For more information on the EBM, see the *TMS470R1x Expansion Bus Module (EBM) Reference Guide* (literature number SPNU222).

The A288 device also has an external clock prescaler (ECP) module that when enabled, outputs a continuous external clock (ECLK) on a specified GIO pin. The ECLK frequency is a user-programmable ratio of the peripheral interface clock (ICLK) frequency. For more detailed functional information on the ECP, see the *TMS470R1x External Clock Prescaler (ECP) Reference Guide* (literature number SPNU202).

## Device Characteristics

The A288 device is a derivative of the F05 system emulation device SE470R1VB8AD. [Table 1](#) identifies all the characteristics of the A288 device except the SYSTEM and CPU, which are generic.

**Table 1. Device Characteristics**

CHARACTERISTICS	DEVICE DESCRIPTION TMS470R1A288	COMMENTS
<b>MEMORY</b>		
For the number of memory selects on this device, see <a href="#">Table 3</a> , <i>TMS470R1A288 Memory Selection Assignment</i> .		
INTERNAL MEMORY	Pipeline/Non-Pipeline 288K-Byte Flash 16K-Byte SRAM Memory Security Module (MSM) JTAG Security Module (JSM)	Flash is pipeline-capable. The A288 RAM is implemented in one 16K-byte array selected by two memory-select signals (see <a href="#">Table 3</a> , <i>TMS470R1A288 Memory Selection Assignment</i> ).
<b>PERIPHERALS</b>		
For the device-specific interrupt priority configurations, see <a href="#">Table 6</a> , <i>Interrupt Priority (IEM and CIM)</i> . For the 1K-byte peripheral address ranges and their peripheral selects, see <a href="#">Table 4</a> , <i>A288 Peripherals, System Module, and Flash Base Addresses</i> .		
CLOCK	ZPLL	Zero-pin phase-locked loop has no external loop filter pins.
EXPANSION BUS	EBM	Expansion bus module with 42 pins. Supports 8- and 16-bit memories. See <a href="#">Table 7</a> for details.
GENERAL-PURPOSE I/Os	50 I/O (PGE Suffix) 14 I/O (PZ Suffix)	In the PGE package, Port A has 8 external pins, Port B has only 1 external pin, Port C has 5 external pins, Port D has 6 external pins, Ports E, F, and G each have 8 external pins, and Port H has 6 external pins. In the PZ package, Port A has 8 external pins, Port B has only 1 external pin, and Port H has 5 external pins.
ECP	YES	
SCI	2 (3-pin)	
CAN (HECC and/or SCC)	2 SCC	Two standard CAN controllers
SPI (5-pin, 4-pin or 3-pin)	2 (5-pin)	
C2S1b	1	
I2C	3	
HET with XOR SHARE	12 I/O	The high-resolution (HR) SHARE feature allows even-numbered HR pins to share the next higher odd HR pin structures. This HR sharing is independent of whether or not the odd pin is available externally. If an odd pin is available externally and shared, then the odd pin can only be used as a general-purpose I/O. For more information on HR SHARE, see the <i>TMS470R1x High-End Timer (HET) Reference Guide</i> (literature number SPNU199).
HET RAM	64-Instruction Capacity	
MibADC	10-bit, 12-channel 64-word FIFO	Both the logic and registers for a full 16-channel MibADC are present.
CORE VOLTAGE	1.8 V	
I/O VOLTAGE	3.3 V	
PINS	144 100	
PACKAGES	PGE PZ	

Functional Block Diagram

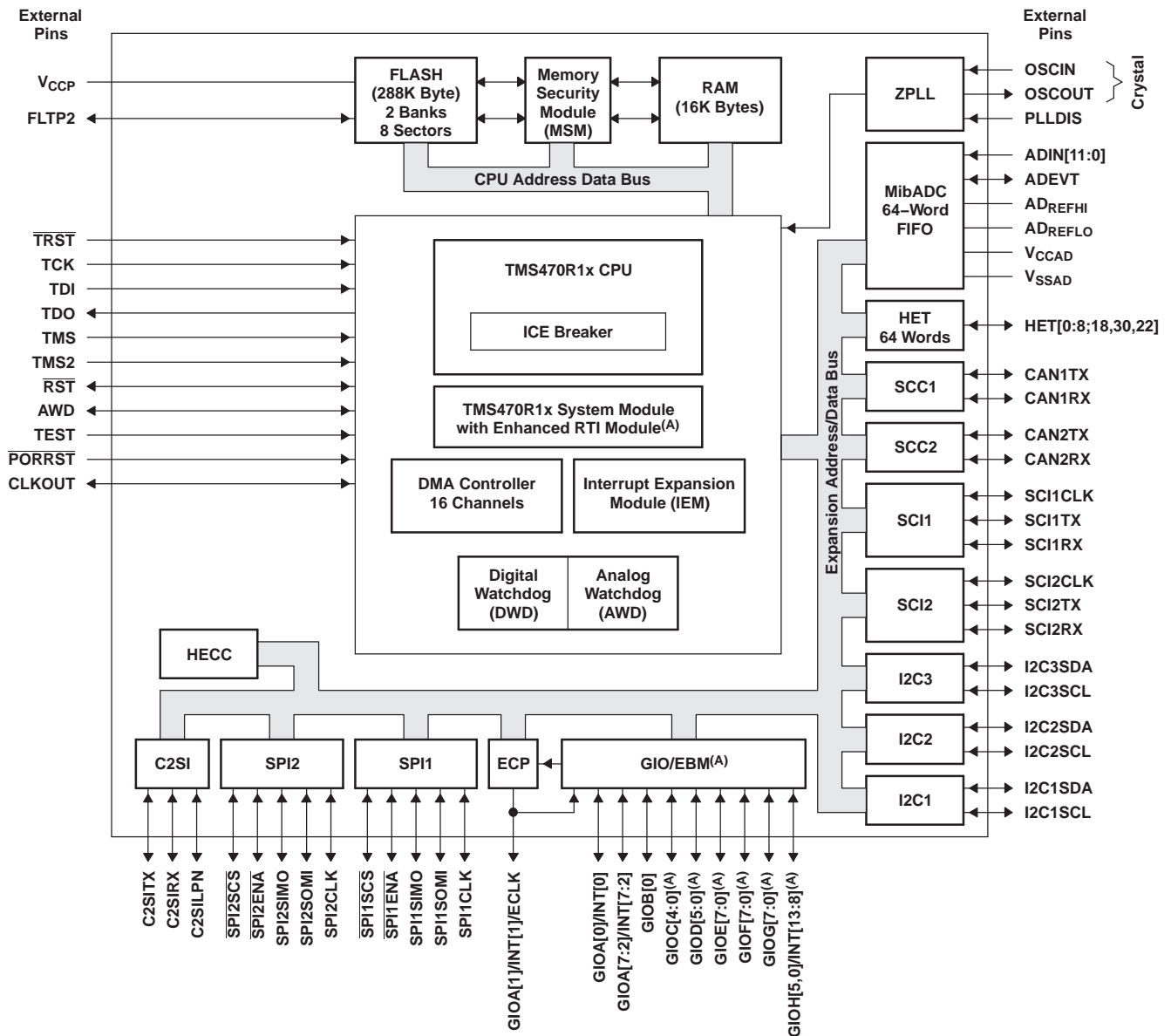

- A. The enhanced RTI module is the system module with two extra bits to disable the ZPLL while in STANDBY mode.
- B. GIOC[4:0], GIOD[5:0], GIOE[5:0], GIOF[7:0], and GIOH[0], which are muxed with EBM, are not available on the PZ package. See [Table 7](#) for EBM-to-GIO mapping.

**Table 2. Terminal Functions**

TERMINAL			INPUT VOLTAGE <sup>(1)(2)</sup>	OUTPUT CURRENT <sup>(3)</sup>	INTERNAL PULLUP/PULLDOWN	DESCRIPTION
NAME	PZ	PGE				
<b>HIGH-END TIMER (HET)</b>						
HET[0]	51	73	3.3-V	2 mA -z		Timer input capture or output compare. The HET[8:0,18,20,22] applicable pins can be programmed as general-purpose input/output (GIO) pins. All are high-resolution pins. The high-resolution (HR) SHARE feature allows even HR pins to share the next higher odd HR pin structures. This HR sharing is independent of whether or not the odd pin is available externally. If an odd pin is available externally and shared, then the odd pin can only be used as a general-purpose I/O. For more information on HR SHARE, see the <i>TMS470R1x High-End Timer (HET) Reference Guide</i> (literature number SPNU199).
HET[1]	50	72				
HET[2]	49	71				
HET[3]	46	66				
HET[4]	45	65				
HET[5]	44	63				
HET[6]	6	9				
HET[7]	7	11				
HET[8]	8	12				
HET[18]	9	15				
HET[20]	12	18				
HET[22]	13	19				
<b>STANDARD CAN CONTROLLER (SCC)</b>						
CAN1SRX	58	83	5 V tolerant	4 mA		SCC1 receive pin or GIO pin
CAN1STX	59	84	3.3-V	2 mA -z		SCC1 transmit pin or GIO pin
CAN2SRX	37	54	5 V tolerant	4 mA		SCC2 receive pin or GIO pin
CAN2STX	38	55	3.3-V	2 mA -z		SCC 2 transmit pin or GIO pin
<b>CLASS II SERIAL INTERFACE (C2SIB)</b>						
C2SILPN	14	21	3.3-V	2 mA -z		C2S1b module loopback enable pin or GIO pin
C2SIRX	15	22	5 V tolerant	4 mA		C2S1b module receive data input pin or GIO pin
C2SITX	16	24	3.3-V	2 mA -z		C2S1b module transmit data output pin or GIO pin
<b>GENERAL-PURPOSE I/O (GIO)</b>						
GIOA[0]/INT[0]	99	141	5 V tolerant	4 mA		General-purpose input/output pins. GIOA[7:0]/INT[7:0] are interrupt-capable pins. GIOA[1]/INT[1]/ECLK pin is multiplexed with the external clock-out function of the external clock prescale (ECP) module.
GIOA[1]/INT[1]/ECLK	96	136				
GIOA[2]/INT[2]	95	134				
GIOA[3]/INT[3]	94	133				
GIOA[4]/INT[4]	89	127				
GIOA[5]/INT[5]	67	98				
GIOA[6]/INT[6]	55	78				
GIOA[7]/INT[7]	56	79				
GIOB[0]/DMAREQ[0]	30	43	3.3-V	2 mA -z	IPD (20 µA)	GIOB[0], GIOC[4:0], GIOD[5:0], GIOE[7:0:], GIOF[7:0], GIOG[7:0], and GIOH[5:0] are multiplexed with the expansion bus module. See <a href="#">Table 7</a> .
GIOC[0]/EBOE	-	135				
GIOC[1]/EBWR[0]	-	128				
GIOC[2]/EBWR[1]	-	126				
GIOC[3]/EBCS[5]	-	120				
GIOC[4]/EBCS[6]	-	119				

(1) PWR = power, GND = ground, REF = reference voltage, NC = no connect

(2) All I/O pins, except  $\overline{RST}$ , are configured as inputs while  $\overline{PORRST}$  is low and immediately after  $\overline{PORRST}$  goes high.

(3) IPD = internal pulldown, IPU = internal pullup (all internal pullups and pulldowns are active on input pins, independent of the  $\overline{PORRST}$  state.)

**Table 2. Terminal Functions (continued)**

TERMINAL			INPUT VOLTAGE <sup>(1)(2)</sup>	OUTPUT CURRENT <sup>(3)</sup>	INTERNAL PULLUP/ PULLDOWN	DESCRIPTION
NAME	PZ	PGE				
<b>GENERAL-PURPOSE I/O (GIO) (CONTINUED)</b>						
GIOD[0]/EBADDR[0]	-	42	3.3-V	2 mA -z	IPD (20 µA)	GIOB[0], GIOC[4:0], GIOD[5:0], GIOE[7:0:], GIOF[7:0], GIOG[7:0], AND GIOH[5:0] are multiplexed with the expansion bus module. See <a href="#">Table 7</a> .
GIOD[1]/EBADDR[1]	-	39				
GIOD[2]/EBADDR[2]	-	35				
GIOD[3]/EBADDR[3]	-	30				
GIOD[4]/EBADDR[4]	-	27				
GIOD[5]/EBADDR[5]	-	23				
GIOE[0]/EBDATA[0]	-	44				
GIOE[1]/EBDATA[1]	-	47				
GIOE[2]/EBDATA[2]	-	58				
GIOE[3]/EBDATA[3]	-	61				
GIOE[4]/EBDATA[4]	-	64				
GIOE[5]/EBDATA[5]	-	67				
GIOE[6]/EBDATA[6]	-	70				
GIOE[7]/EBDATA[7]	-	77				
GIOF[0]/EBADDR[6]/ EBDATA[8]	-	80				
GIOF[1]/EBADDR[7]/ EBDATA[9]	-	82				
GIOF[2]/EBADDR[8]/ EBDATA[10]	-	89				
GIOF[3]/EBADDR[9]/ EBDATA[11]	-	90				
GIOF[4]/EBADDR[10]/ EBDATA[12]	-	93				
GIOF[5]/EBADDR[11]/ EBDATA[13]	-	96				
GIOF[6]/EBADDR[12]/ EBDATA[14]	-	99				
GIOF[7]/EBADDR[13]/ EBDATA[15]	-	100				
GIOG[0]/EBADDR[14]/ EBADDR[6]	-	20				
GIOG[1]/EBADDR[15]/ EBADDR[7]	-	10				
GIOG[2]/EBADDR[16]/ EBADDR[8]	-	8				
GIOG[3]/EBADDR[17]/ EBADDR[9]	-	6				

**Table 2. Terminal Functions (continued)**

TERMINAL			INPUT VOLTAGE <sup>(1)(2)</sup>	OUTPUT CURRENT <sup>(3)</sup>	INTERNAL PULLUP/PULLDOWN	DESCRIPTION
NAME	PZ	PGE				
<b>GENERAL-PURPOSE I/O (GIO) (CONTINUED)</b>						
GIOG[4]/EBADDR[18] /EBADDR[10]	-	3	3.3-V	2 mA -z	IPD (20 µA)	GIOB[0], GIOC[4:0], GIOD[5:0], GIOE[7:0:], GIOF[7:0], GIOG[7:0], AND GIOH[5:0] are multiplexed with the expansion bus module. See <a href="#">Table 7</a> .  GIOH[5:0]/INT[13:8] are interrupt-capable pins.
GIOG[5]/EBADDR[19] /EBADDR[11]	-	143				
GIOG[6]/EBADDR[20] /EBADDR[12]	-	142				
GIOG[7]/EBADDR[21] /EBADDR[13]	-	140				
GIOH[0]/EBADDR[22] /EBADDR[14]/INT[8]	-	139		2 mA		
GIOH[1]/EBADDR[23] /EBADDR[15]/INT[9]	29	41				
GIOH[2]/EBADDR[24] /EBADDR[16]/INT[10]	28	40				
GIOH[3]/EBADDR[25] /EBADDR[17]/INT[11]	27	38				
GIOH[4]/EBADDR[26] /EBADDR[18]/INT[12]	26	37				
GIOH[5]/EBHOLD/ INT[13]	88	125				
<b>MULTI-BUFFERED ANALOG-TO-DIGITAL CONVERTER (MibADC)</b>						
ADEVT	68	101	3.3-V	2 mA -z		MibADC event input. Can be programmed as a GIO pin.
ADIN[0]	84	117	3.3-V			MibADC analog input pins
ADIN[1]	83	116				
ADIN[2]	82	115				
ADIN[3]	81	114				
ADIN[4]	80	113				
ADIN[5]	75	108				
ADIN[6]	74	107				
ADIN[7]	73	106				
ADIN[8]	72	105				
ADIN[9]	71	104				
ADIN[10]	70	103				
ADIN[11]	69	102				
AD <sub>REFHI</sub>	76	109	3.3-V REF			MibADC module high-voltage reference input
AD <sub>REFLO</sub>	77	110	GND REF			MibADC module low-voltage reference input
V <sub>CCAD</sub>	78	111	3.3-V PWR			MibADC analog supply voltage
V <sub>SSAD</sub>	79	112	GND			MibADC analog ground reference

**Table 2. Terminal Functions (continued)**

TERMINAL			INPUT VOLTAGE <sup>(1)(2)</sup>	OUTPUT CURRENT <sup>(3)</sup>	INTERNAL PULLUP/ PULLDOWN	DESCRIPTION
NAME	PZ	PGE				
<b>SERIAL PERIPHERAL INTERFACE 1 (SPI1)</b>						
SPI1CLK	3	4	5 V tolerant	4 mA		SPI1 clock. SPI1CLK can be programmed as a GIO pin.
SPI1ENA	2	2				SPI1 chip enable. Can be programmed as a GIO pin.
SPI1SCS	1	1				SPI1 slave chip select. Can be programmed as a GIO pin.
SPI1SIMO	4	5				SPI1 data stream. Slave in/master out. Can be programmed as a GIO pin.
SPI1SOMI	5	7				SPI1 data stream. Slave out/master in. Can be programmed as a GIO pin.
<b>SERIAL PERIPHERAL INTERFACE 2 (SPI2)</b>						
SPI2CLK	39	56	5 V tolerant	4 mA		SPI2 clock. Can be programmed as a GIO pin.
SPI2ENA	42	60				SPI2 chip enable. Can be programmed as a GIO pin.
SPI2SCS	43	62				SPI2 slave chip select. Can be programmed as a GIO pin.
SPI2SIMO	41	59				SPI2 data stream. Slave in/master out. Can be programmed as a GIO pin.
SPI2SOMI	40	57				SPI2 data stream. Slave out/master in. Can be programmed as a GIO pin.
<b>INTER-INTEGRATED CIRCUIT (I2C)</b>						
I2C1SDA	60	87	5 V tolerant	4 mA		I2C1 serial data pin or GIO pin
I2C1SCL	61	88				I2C1 serial clock pin or GIO pin
I2C2SDA	64	94				I2C2 serial data pin or GIO pin
I2C2SCL	65	95				I2C2 serial clock pin or GIO pin
I2C3SDA	20	29				I2C3 serial data pin or GIO pin
I2C3SCL	19	28				I2C3 serial clock pin or GIO pin
<b>ZERO-PIN PHASE-LOCKED LOOP (ZPLL)</b>						
OSCIN	23	33	1.8-V			Crystal connection pin or external clock input
OSCOUT	22	32		2 mA		External crystal connection pin
PLLDIS	66	97	3.3-V		IPD (20 µA)	Enable/disable the ZPLL. The ZPLL can be bypassed and the oscillator becomes the system clock. If not in bypass mode, TI recommends that this pin be connected to ground or pulled down to ground by an external resistor.
<b>SERIAL COMMUNICATIONS INTERFACE 1 (SCI1)</b>						
SCI1CLK	33	48	3.3-V	2 mA -z		SCI1 clock. SCI1CLK can be programmed as a GIO pin.
SCI1RX	32	46	5 V tolerant	4 mA		SCI1 data receive. SCI1RX can be programmed as a GIO pin.
SCI1TX	31	45	3.3-V	2 mA -z		SCI1 data transmit. SCI1TX can be programmed as a GIO pin.
<b>SERIAL COMMUNICATIONS INTERFACE 2 (SCI2)</b>						
SCI2CLK	36	51	3.3-V	2 mA -z		SCI2 clock. SCI2CLK can be programmed as a GIO pin.
SCI2RX	35	50	5 V tolerant	4 mA		SCI2 data receive. SCI2RX can be programmed as a GIO pin.
SCI2TX	34	49	3.3-V	2 mA -z		SCI2 data transmit. SCI2TX can be programmed as a GIO pin.

**Table 2. Terminal Functions (continued)**

TERMINAL			INPUT VOLTAGE <sup>(1)(2)</sup>	OUTPUT CURRENT <sup>(3)</sup>	INTERNAL PULLUP/PULLDOWN	DESCRIPTION
NAME	PZ	PGE				
<b>SYSTEM MODULE (SYS)</b>						
CLKOUT	57	81	3.3-V	8 mA		Bidirectional pin. CLKOUT can be programmed as a GIO pin or the output of SYSCLK, ICLK, or MCLK.
$\overline{\text{PORRST}}$	85	118	3.3-V		IPD (20 $\mu$ A)	Input master chip power-up reset. External V <sub>CC</sub> monitor circuitry must assert a power-on reset.
$\overline{\text{RST}}$	86	121	3.3-V	4 mA	IPU (20 $\mu$ A)	Bidirectional reset. The internal circuitry can assert a reset, and an external system reset can assert a device reset. On this pin, the output buffer is implemented as an open drain (drives low only). To ensure an external reset is not arbitrarily generated, TI recommends that an external pullup resistor be connected to this pin.
<b>WATCHDOG/REAL-TIME INTERRUPT (WD/RTI)</b>						
AWD	25	36	3.3-V	8 mA		Analog watchdog reset. The AWD pin provides a system reset if the WD KEY is not written in time by the system, providing an external RC network circuit is connected. If the user is not using AWD, TI recommends that this pin be connected to ground or pulled down to ground by an external resistor.  For more details on the external RC network circuit, see the <i>TMS470R1x System Module Reference Guide</i> (literature number SPNU189).
<b>TEST/DEBUG (T/D)</b>						
TCK	54	76	3.3-V		IPD (20 $\mu$ A)	Test clock. TCK controls the test hardware (JTAG).
TDI	52	74		8 mA		Test data in. TDI inputs serial data to the test instruction register, test data register, and programmable test address (JTAG).
TDO	53	75		8 mA		Test data out. TDO outputs serial data from the test instruction register, test data register, identification register, and programmable test address (JTAG).
TEST	87	124				Test enable. Reserved for internal use only. TI recommends that this pin be connected to ground or pulled down to ground by an external resistor.
TMS	11	17		8 mA		Serial input for controlling the state of the CPU test access port (TAP) controller (JTAG).
TMS2	10	16		8 mA		Serial input for controlling the second TAP. TI recommends that this pin be connected to VCCIO or pulled up to VCCIO by an external resistor.
$\overline{\text{TRST}}$	100	144				Test hardware reset to TAP1 and TAP2. IEEE Standard 1149-1 (JTAG) Boundary-Scan Logic. TI recommends that this pin be pulled down to ground by an external resistor.

**Table 2. Terminal Functions (continued)**

TERMINAL			INPUT VOLTAGE <sup>(1)(2)</sup>	OUTPUT CURRENT <sup>(3)</sup>	INTERNAL PULLUP/ PULLDOWN	DESCRIPTION
NAME	PZ	PGE				
<b>FLASH</b>						
FLTP2	93	132	NC	NC		Flash test pad 2. For proper operation, this pin must not be connected [no connect (NC)].
V <sub>CCP</sub>	92	131	3.3-V PWR			Flash external pump voltage (3.3 V)
<b>SUPPLY VOLTAGE CORE (1.8 V)</b>						
V <sub>CC</sub>	21	13	1.8-V	PWR		Core logic supply voltage
	63	31				
	91	53				
	-	92				
	-	123				
	-	130				
<b>SUPPLY VOLTAGE DIGITAL I/O (3.3 V)</b>						
V <sub>CCIO</sub>	17	25	3.3-V	PWR		Digital I/O supply voltage
	48	69				
	-	86				
	97	137				
<b>SUPPLY GROUND CORE</b>						
V <sub>SS</sub>	90	14	GND			Core supply ground reference
	-	34				
	-	52				
	-	91				
	62	122				
	24	129				
<b>SUPPLY GROUND DIGITAL I/O</b>						
V <sub>SSIO</sub>	18	26	GND			Digital I/O supply ground reference
	47	68				
	-	85				
	98	138				

**TMS470R1A288 DEVICE-SPECIFIC INFORMATION**

**Memory**

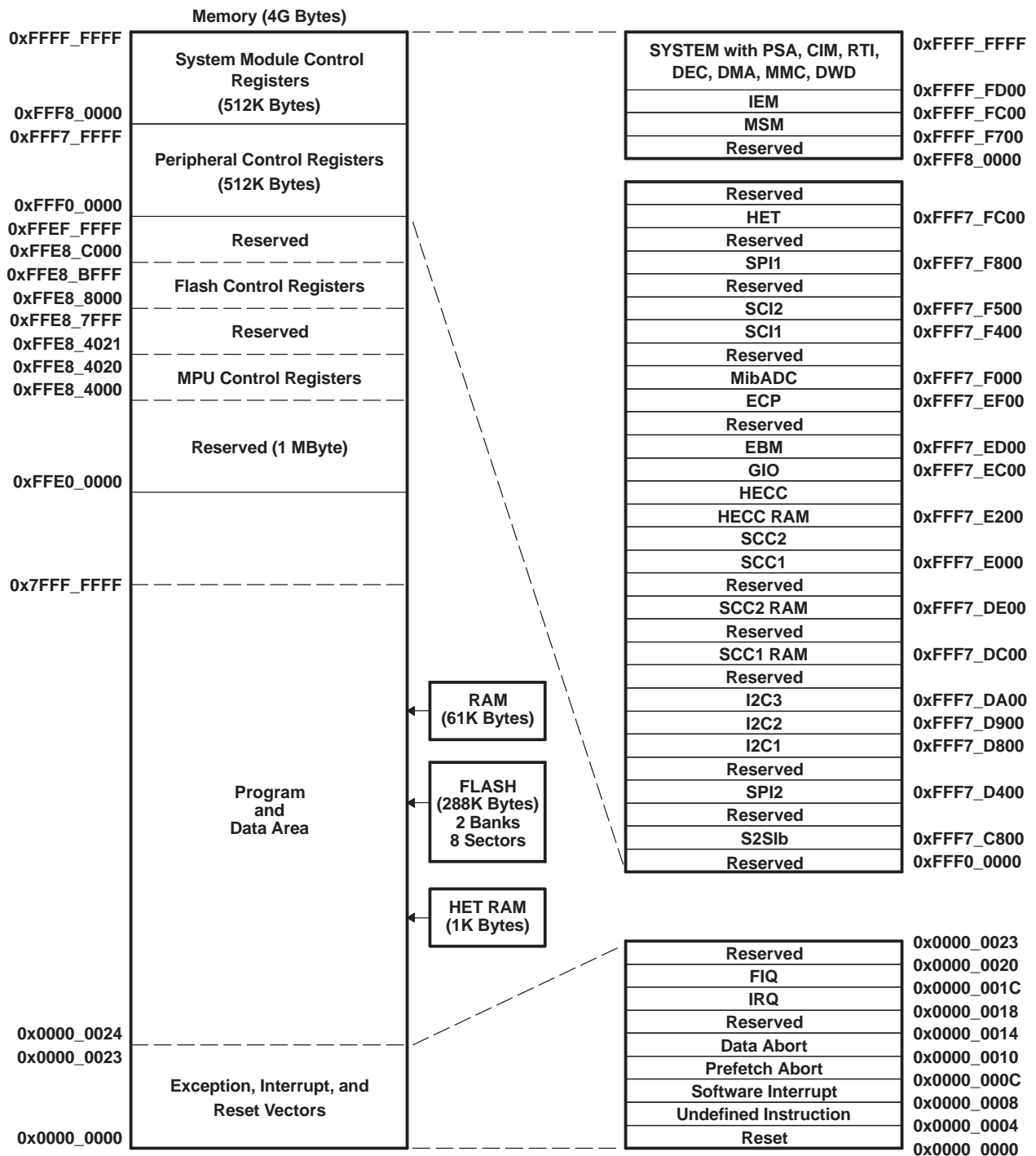

- A. Memory addresses are configurable by the system (SYS) module within the range of 0x0000\_0000 to 0xFFE0\_0000.
- B. The CPU registers are not a part of the memory map.

**Figure 1. TMS470R1A288 Memory Map**

## Memory Selects

Memory selects allow the user to address memory arrays (i.e., flash, RAM, and HET RAM) at user-defined addresses. Each memory select has its own set (low and high) of memory base address registers (MFBAHRx and MFBALRx) that, together, define the array's starting (base) address, block size, and protection.

The base address of each memory select is configurable to any memory address boundary that is a multiple of the decoded block size. For more information on how to control and configure these memory select registers, see the bus structure and memory sections of the *TMS470R1x System Module Reference Guide* (literature number SPNU189).

For the memory selection assignments and the memory selected, see [Table 3](#).

**Table 3. TMS470R1A288 Memory Selection Assignment**

MEMORY SELECT	MEMORY SELECTED (ALL INTERNAL)	MEMORY SIZE <sup>(1)</sup>	MPU	MSM	MEMORY BASE ADDRESS REGISTER	STATIC MEM CTL REGISTER
0 (fine)	FLASH/ROM	288K	NO	YES	MFBAHR0 and MFBALR0	
1 (fine)	FLASH/ROM		NO	YES	MFBAHR1 and MFBALR1	
2 (fine)	RAM	16K <sup>(2)</sup>	YES	YES	MFBAHR2 and MFBALR2	
3 (fine)	RAM		YES	YES	MFBAHR3 and MFBALR3	
4 (fine)	HET RAM	1K	NO	NO	MFBAHR4 and MFBALR4	SMCR1
5 (coarse)	$\overline{CS}[5]/GIOC[3]$	128 MB (x8) 1MB (x16)	NO	NO	MCBAHR2 and MCBALR2	SMCR5
6 (coarse)	$\overline{CS}[6]/GIOC[4]$	128 MB (x8) 1MB (x16)	NO	NO	MCBAHR3 and MCBALR3	SMCR6

(1) x8 refers to size of memory in 8-bits; x16 refers to size of memory in 16-bits.

(2) The starting addresses for both RAM memory-select signals cannot be offset from each other by a multiple of the user-defined block size in the memory-base address register.

## Memory Security Module

The A288 device also includes a memory security module (MSM) to provide additional security and flexibility to the memory contents' protection. The password for unlocking the MSM is located in the four words just before the flash protection keys (see the *Flash Protection Keys* section below).

## JTAG Security Module (JSM)

The A288 device includes a JTAG security module to provide maximum security to the memory contents. The visible unlock code can be chosen to be in the OTP sector or in the first bank of the user-programmable memory. For the A288, the visible unlock code is in the OTP sector.

## RAM

The A288 device contains 16K-bytes of internal static RAM configurable by the SYS module to be addressed within the range of 0x0000\_0000 to 0xFFE0\_0000. This A288 RAM is implemented in one 16K-byte array selected by two memory-select signals.

### NOTE:

This A288 configuration imposes an additional constraint on the memory map for RAM; the starting addresses for both RAM memory selects cannot be offset from each other by the multiples of the size of the physical RAM (i.e., 16K for the A288 device). The A288 RAM is addressed through memory selects 2 and 3.

The RAM can be protected by the memory protection unit (MPU) portion of the SYS module, allowing the user finer blocks of memory protection than is allowed by the memory selects. The MPU is ideal for protecting an operating system while allowing access to the current task. For more detailed information on the MPU portion of the SYS module and memory protection, see the memory section of the *TMS470R1x System Module Reference Guide* (literature number SPNU189).

**F05 Flash**

The F05 flash memory is a nonvolatile electrically erasable and programmable memory implemented with a 32-bit-wide data bus interface. The F05 flash has an external state machine for programming and erase functions. See the *Flash Read* and *Flash Program and Erase* sections below.

**Flash Protection Keys**

The A288 device provides flash protection keys. These four 32-bit protection keys prevent program/erase/compaction operations from occurring until after the four protection keys have been matched by the CPU loading the correct user keys into the FMPKEY control register. The protection keys on the A288 are located in the last 4 words of the first 8K sector. For more detailed information on the flash protection keys and the FMPKEY control register, see the "Optional Quadruple Protection Keys" and "Programming the Protection Keys" portions of the *TMS470R1x F05 Flash Reference Guide* (literature number SPNU213).

**Flash Read**

The A288 flash memory is configurable by the SYS module to be addressed within the range of 0x0000\_0000 to 0xFFE0\_0000. The flash is addressed through memory selects 0 and 1.

**NOTE:**

The flash external pump voltage ( $V_{CCP}$ ) is required for all operations (program, erase, and read).

**Flash Pipeline Mode**

When in pipeline mode, the flash operates with a system clock frequency of up to 48 MHz. In normal mode, the flash operates with a system clock frequency of up to 24 MHz. Flash in pipeline mode is capable of accessing 64-bit words and provides two 32-bit pipelined words to the CPU. Also, in pipeline mode the flash can be read with no wait states when memory addresses are contiguous (after the initial 1- or 2-wait-state reads).

**NOTE:**

After a system reset, pipeline mode is disabled (FMREGOPT[0] is a 0). In other words, the A288 device powers up and comes out of reset in non-pipeline mode. Furthermore, setting the flash configuration mode bit (GBLCTRL[4]) will override pipeline mode.

**Flash Program and Erase**

The A288 device flash contains one 32K-byte memory array (or bank) and one 256K-byte bank, for a total of 288K-bytes of flash, and consists of eight sectors. These eight sectors are sized as follows:

SECTOR NO.	SEGMENT	LOW ADDRESS	HIGH ADDRESS	MEMORY ARRAYS (OR BANKS)
OTP	2K Bytes	0x0000_0000	0x0000_07FF	BANK0 (32K Bytes)
0	8K Bytes	0x0000_0000	0x0000_1FFF	
1	8K Bytes	0x0000_2000	0x0000_3FFF	
2	8K Bytes	0x0000_4000	0x0000_5FFF	
3	8K Bytes	0x0000_6000	0x0000_7FFF	
0	64K Bytes	0x0004_0000	0x0004_FFFF	BANK1 (256K Bytes)
1	64K Bytes	0x0005_0000	0x0005_FFFF	
2	64K Bytes	0x0006_0000	0x0006_FFFF	
3	64K Bytes	0x0007_0000	0x0007_FFFF	

The minimum size for an erase operation is one sector. The maximum size for a program operation is one 16-bit word.

**NOTE:**

The flash external pump voltage ( $V_{CCP}$ ) is required for all operations (program, erase, and read).

Execution can occur from one bank while programming/erasing any or all sectors of another bank. However, execution can not occur from any sector within a bank that is being programmed or erased.

For more detailed information on flash program and erase operations, see the *TMS470R1x F05 Flash Reference Guide* (literature number SPNU213).

**HET RAM**

The A288 device contains HET RAM. The HET RAM has a 64-instruction capability. The HET RAM is configurable by the SYS module to be addressed within the range of 0x0000\_0000 to 0xFFE0\_0000. The HET RAM is addressed through memory select 4.

**XOR Share**

The A288 HET peripheral contains the XOR-share feature. This feature allows two adjacent HET high-resolution channels to be XORed together, making it possible to output smaller pulses than a standard HET. For more detailed information on the HET XOR-share feature, see the *TMS470R1x High-End Timer (HET) Reference Guide* (literature number SPNU199).

**Peripheral Selects and Base Addresses**

The A288 device uses 10 of the 16 peripheral selects to decode the base addresses of the peripherals. These peripheral selects are fixed and transparent to the user because they are part of the decoding scheme used by the SYS module.

Control registers for the peripherals, SYS module, and flash begin at the base addresses shown in [Table 4](#).

**Table 4. A288 Peripherals, System Module, and Flash Base Addresses**

CONNECTING MODULE	ADDRESS RANGE		PERIPHERAL SELECTS
	BASE ADDRESS	ENDING ADDRESS	
SYSTEM	0xFFFF_FF00	0xFFFF_FFFF	N/A
RESERVED	0xFFFF_FF70	0xFFFF_FFCB	N/A
DWD	0xFFFF_FF60	0xFFFF_FF6F	N/A
PSA	0xFFFF_FF40	0xFFFF_FF5F	N/A
CIM	0xFFFF_FF20	0xFFFF_FF3F	N/A
RTI	0xFFFF_FF00	0xFFFF_FF1F	N/A
DMA	0xFFFF_FE80	0xFFFF_FEFF	N/A
DEC	0xFFFF_FE00	0xFFFF_FE7F	N/A
RESERVED	0xFFFF_FD80	0xFFFF_FDFF	N/A
MMC	0xFFFF_FD00	0xFFFF_FD7F	N/A
IEM	0xFFFF_FC00	0xFFFF_FCFE	N/A
RESERVED	0xFFFF_FB00	0xFFFF_FBF7	N/A
RESERVED	0xFFFF_FA00	0xFFFF_FAFF	N/A
DMA CMD BUFFER	0xFFFF_F800	0xFFFF_F9FF	N/A
MSM	0xFFFF_F700	0xFFFF_F7FF	N/A
RESERVED	0xFFFF_F600	0xFFFF_F6FF	N/A
RESERVED	0xFFFF_FD00	0xFFFF_FDFF	PS[0]
HET	0xFFFF_FC00	0xFFFF_FCFE	

**Table 4. A288 Peripherals, System Module, and Flash Base Addresses (continued)**

CONNECTING MODULE	ADDRESS RANGE		PERIPHERAL SELECTS
	BASE ADDRESS	ENDING ADDRESS	
RESERVED	0xFFF7_F900	0xFFF7_FBFF	PS[1]
SPI1	0xFFF7_F800	0xFFF7_F8FF	
RESERVED	0xFFF7_F600	0xFFF7_F7FF	PS[2]
SCI2	0xFFF7_F500	0xFFF7_F5FF	
SCI1	0xFFF7_F400	0xFFF7_F4FF	PS[3]
RESERVED	0xFFF7_F100	0xFFF7_F3FF	
MibADC	0xFFF7_F000	0xFFF7_F0FF	PS[4]
ECP	0xFFF7_EF00	0xFFF7_EFFF	
RESERVED	0xFFF7_EE00	0xFFF7_EEFF	PS[5]
EBM	0xFFF7_ED00	0xFFF7_EDFF	
GIO	0xFFF7_EC00	0xFFF7_ECFE	PS[6]
HECC	0xFFF7_EA00	0xFFF7_EBFF	
RESERVED	0xFFF7_E800	0xFFF7_E9FF	PS[7]
HECC RAM	0xFFF7_E600	0xFFF7_E7FF	
RESERVED	0xFFF7_E400	0xFFF7_E5FF	PS[8]
RESERVED	0xFFF7_E300	0xFFF7_E3FF	
SCC2	0xFFF7_E200	0xFFF7_E2FF	PS[9]
RESERVED	0xFFF7_E100	0xFFF7_E1FF	
SCC1	0xFFF7_E000	0xFFF7_E0FF	PS[10]
RESERVED	0xFFF7_DF00	0xFFF7_DFFF	
SCC2 RAM	0xFFF7_DE00	0xFFF7_DEFF	PS[11] - PS[12]
RESERVED	0xFFF7_DD00	0xFFF7_DDFF	
SCC1 RAM	0xFFF7_DC00	0xFFF7_DCFF	PS[13]
RESERVED	0xFFF7_DB00	0xFFF7_DBFF	
I2C3	0xFFF7_DA00	0xFFF7_DAFF	PS[14] - PS[15]
I2C2	0xFFF7_D900	0xFFF7_D9FF	
I2C1	0xFFF7_D800	0xFFF7_D8FF	N/A
RESERVED	0xFFF7_D500	0xFFF7_D7FF	
SPI2	0xFFF7_D400	0xFFF7_D4FF	N/A
RESERVED	0xFFF7_CC00	0xFFF7_D3FF	
RESERVED	0xFFF7_C900	0xFFF7_CBFF	N/A
C2S1b	0xFFF7_C800	0xFFF7_C8FF	
RESERVED	0xFFF7_C000	0xFFF7_C7FF	N/A
RESERVED	0xFFF0_0000	0xFFF7_BFFF	
Flash Control Registers	0xFFE8_8000	0xFFE8_BFFF	N/A
RESERVED	0xFFF8_4024	0xFFF8_7FFF	N/A
MPU Control Registers	0xFFE8_4000	0xFFE8_4023	N/A
RESERVED	0xFFF8_0000	0xFFF8_3FFF	N/A

## Direct-Memory Access (DMA)

The direct-memory access (DMA) controller transfers data to and from any specified location in the A288 memory map (except for restricted memory locations such as the system control registers area). The DMA manages up to 16 channels, and supports data transfer for both on-chip and off-chip memories and peripherals. The DMA controller is connected to both the CPU and peripheral buses, enabling these data transfers to occur in parallel with CPU activity and thus maximizing overall system performance.

Although the DMA controller has two possible configurations for the A288 device, the DMA controller configuration is 32 control packets and 16 channels.

For the A288 DMA request hardwired configuration, see [Table 5](#).

**Table 5. DMA Request Lines Connections<sup>(1)</sup>**

MODULES	DMA REQUEST INTERRUPT SOURCES		DMA CHANNEL
EBM	Expansion Bus DMA request	EBDMAREQ0	DMAREQ[0]
SPI1	SPI1 end-receive	SPI1DMA0	DMAREQ[1]
SPI1	SPI1 end-transmit	SPI1DMA1	DMAREQ[2]
MibADC/I2C1	ADC EV/I2C1 read	MibADCDMA0/I2C1DMA0	DMAREQ[3]
MibADC/SCI1	ADC G1/SCI1 end-receive	MibADCDMA1/SCI1DMA0	DMAREQ[4]
MibADC/SCI1	ADC G2/SCI1 end-transmit	MibADCDMA2/SCI1DMA1	DMAREQ[5]
I2C1	I2C1 write	I2C1DMA1	DMAREQ[6]
SPI2	SPI2 end-receive	SPI2DMA0	DMAREQ[7]
SPI2	SPI2 end-transmit	SPI2DMA1	DMAREQ[8]
I2C2/C2S1b	I2C2 read end-receive/C2S1b end-receive	I2C2DMA0/C2SIDMA0	DMAREQ[9]
I2C2/C2S1b	I2C2 write end-transmit/C2S1b end-transmit	I2C2DMA1/C2SIDMA1	DMAREQ[10]
I2C3	I2C3 read	I2C3DMA0	DMAREQ[11]
I2C3	I2C3 write	I2C3DMA1	DMAREQ[12]
Reserved			DMAREQ[13]
SCI2	SCI2 end-receive	SCI2DMA0	DMAREQ[14]
SCI2	SCI2 end-transmit	SCI2DMA1	DMAREQ[15]

(1) For DMA channels with more than one assigned request source, only one of the sources listed can be the DMA request generator in a given application. The device has software control to ensure that there are no conflicts between requesting modules.

Each channel has two control packets attached to it, allowing the DMA to continuously load RAM and generate periodic interrupts so that the data can be read by the CPU. The control packets allow for the interrupt enable, and the channels determine the priority level of the interrupt.

DMA transfers occur in one of two modes:

- Non-request mode (used when transferring from memory to memory)
- Request mode (used when transferring from memory to peripheral)

For more detailed functional information on the DMA controller, see the *TMS470R1x Direct Memory Access (DMA) Controller Reference Guide* (literature number SPNU194).

## Interrupt Priority (IEM to CIM)

Interrupt requests originating from the A288 peripheral modules (i.e., SPI1 or SPI2; SCI1 or SCI2; RTI; etc.) are assigned to channels within the 48-channel interrupt expansion module (IEM) where, via programmable register mapping, these channels are then mapped to the 32-channel central interrupt manager (CIM) portion of the SYS module.

Programming multiple interrupt sources in the IEM to the same CIM channel effectively shares the CIM channel between sources.

The CIM request channels are maskable so that individual channels can be selectively disabled. All interrupt requests can be programmed in the CIM to be of either type:

- Fast interrupt request (FIQ)
- Normal interrupt request (IRQ)

The CIM prioritizes interrupts. The precedences of request channels decrease with ascending channel order in the CIM (0 [highest] and 31 [lowest] priority). For IEM-to-CIM default mapping, channel priorities, and their associated modules, see [Table 6](#).

**Table 6. Interrupt Priority (IEM and CIM)**

MODULES	INTERRUPT SOURCES	DEFAULT CIM INTERRUPT LEVEL/CHANNEL	IEM CHANNEL
SPI1	SPI1 end-transfer/overrun	0	0
RTI	COMP2 interrupt	1	1
RTI	COMP1 interrupt	2	2
RTI	TAP interrupt	3	3
SPI2	SPI2 end-transfer/overrun	4	4
GIO	GIO interrupt A	5	5
Reserved		6	6
HET	HET interrupt 1	7	7
I2C1	I2C1 interrupt	8	8
SCI1/SCI2	SCI1 or SCI2 error interrupt	9	9
SCI1	SCI1 receive interrupt	10	10
C2S1b	C2S1b interrupt	11	11
I2C2	I2C2 interrupt	12	12
SCC2	SCC2 interrupt A	13	13
SCC1	SCC1 interrupt A	14	14
Reserved		15	15
MibADC	MibADC end event conversion	16	16
SCI2	SCI2 receive interrupt	17	17
DMA	DMA interrupt 0	18	18
I2C3	I2C3 interrupt	19	19
SCI1	SCI1 transmit interrupt	20	20
System	SW interrupt (SSI)	21	21
Reserved		22	22
HET	HET interrupt 2	23	23
SCC2	SCC2 interrupt B	24	24
SCC1	SCC1 interrupt B	25	25
SCI2	SCI2 transmit interrupt	26	26
MibADC	MibADC end Group 1 conversion	27	27
DMA	DMA Interrupt 1	28	28
GIO	GIO interrupt B	29	29
MibADC	MibADC end Group 2 conversion	30	30
Reserved		31	31
Reserved		31	32–37
HECC	HECC interrupt A	31	38
HECC	HECC interrupt B	31	39
Reserved		31	40–47

For more detailed functional information on the IEM, see the *TMS470R1x Interrupt Expansion Module (IEM) Reference Guide* (literature number SPNU211). For more detailed functional information on the CIM, see the *TMS470R1x System Module Reference Guide* (literature number SPNU189).

## Expansion Bus Module (EBM)

The expansion bus module (EBM) is a standalone module used to bond out both general-purpose input/output pins and expansion bus interface pins. The module supports 8- and 16-bit expansion bus memory interface mappings, as well as mapping of the following expansion bus signals:

- 27-bit address bus (EBADDR[26:0]) for x8, 19-bit address bus (EBADDR[18:0]) for x16
- 8- or 16-bit data bus (EBDATA[7:0] or EBDATA[15:0])
- 2 write strobes ( $\overline{\text{EBWR}}[1:0]$ )
- 2 memory chip selects ( $\overline{\text{EBCS}}[6:5]$ )
- 1 output enable ( $\overline{\text{EBOE}}$ )
- 1 external hold signal for interfacing to slow memories ( $\overline{\text{EBHOLD}}$ )

Table 7 shows the multiplexing of I/O signals with the expansion bus interface signals. The mapping of these pins varies depending on the memory mode.

**Table 7. Expansion Bus Mux Mapping<sup>(1)</sup>**

GIO	EXPANSION BUS MODULE PINS <sup>(2)</sup>	
	x8	x16
GIOB[0]	EBDMAREQ[0]	EBDMAREQ[0]
GIOC[0]	$\overline{\text{EBOE}}$	$\overline{\text{EBOE}}$
GIOC[2:1]	$\overline{\text{EBWR}}[1:0]$	$\overline{\text{EBWR}}[1:0]$
GIOC[4:3]	$\overline{\text{EBCS}}[6:5]$	$\overline{\text{EBCS}}[6:5]$
GIOD[5:0]	EBADDR[5:0]	EBADDR[5:0]
GIOE[7:0]	EBDATA[7:0]	EBDATA[7:0]
GIOF[7:0]	EBADDR[13:6]	EBDATA[15:8]
GIOG[7:0]	EBADDR[21:14]	EBADDR[13:6]
GIOH[4:0]	EBADDR[26:22]	EBADDR[18:14]
GIOH[5]	$\overline{\text{EBHOLD}}$	$\overline{\text{EBHOLD}}$

(1) These mappings are controlled by the EBM mux control registers B-H (EBMXCRB - EBMXCRH) and the EBM control register 1 (EBMCR1). For GPIO functions, use GIODIRx, GIODINx, GIODOUTx, GIODSETx, and GIODCLR. For more detailed information, see the *TMS470R1x General-Purpose Input/Output (GIO) Reference Guide* (literature number SPNU192) and the *TMS470R1x Expansion Bus Module (EBM) Reference Guide* (literature number SPNU222).

(2) x8 refers to size of memory in 8-bits; x16 refers to size of memory in 16-bits.

Table 8 lists the names of the expansion bus interface signals and their functions.

**Table 8. Expansion Bus Pins**

PIN	DESCRIPTION
EBDMAREQ	Expansion bus DMA request
$\overline{\text{EBOE}}$	Expansion bus output enable
$\overline{\text{EBWR}}$	Expansion bus write strobe. $\overline{\text{EBWR}}[1]$ controls EBDATA[15:8] and $\overline{\text{EBWR}}[0]$ controls EBDATA[7:0].
$\overline{\text{EBCS}}$	Expansion bus chip select
EBADDR	Expansion bus address
EBDATA	Expansion bus data
$\overline{\text{EBHOLD}}$	Expansion bus hold: an external device connected to the expansion bus may assert this signal to add wait states to an expansion bus transaction.

**MibADC**

The multi-buffered analog-to-digital converter (MibADC) accepts an analog signal and converts the signal to a 10-bit digital value.

The A288 MibADC module can function in two modes: compatibility mode, where its programmer's model is compatible with the TMS470R1x ADC module and its digital results are stored in digital result registers; or in buffered mode, where the digital result registers are replaced with three FIFO buffers, one for each conversion group [event, group1 (G1), and group2 (G2)]. In buffered mode, the MibADC buffers can be serviced by interrupts or by the DMA.

**MibADC Event Trigger Enhancements**

The MibADC includes two major enhancements over the event-triggering capability of the TMS470R1x ADC.

- Both group 1 and the event group can be configured for event-triggered operation, providing up to two event-triggered groups.
- The trigger source and polarity can be selected individually for both group 1 and the event group from the options identified in Table 8.

**Table 9. MibADC Event Hookup Configuration**

EVENT NO.	SOURCE SELECT BITS FOR G1 OR EVENT (G1SRC[1:0] OR EVSRC[1:0])	SIGNAL PIN NAME
EVENT1	00	ADEVT
EVENT2	01	HET18
EVENT3	10	Reserved
EVENT4	11	Reserved

For group 1, these event-triggered selections are configured via the group 1 source select bits (G1SRC[1:0]) in the AD event source register (ADEVTSRC[5:4]). For the event group, these event-triggered selections are configured via the event group source select bits (EVSRC[1:0]) in the AD event source register (ADEVTSRC[1:0]).

For more detailed functional information on the MibADC, see the *TMS470R1x Multi-Buffered Analog-to-Digital Converter (MibADC) Reference Guide* (literature number SPNU206).

**JTAG Interface**

There are two main test access ports (TAPs) on the A288 device:

- TMS470R1x CPU TAP
- Device TAP for factory test

Some of the JTAG pins are shared among these two TAPs. The hookup is illustrated in [Figure 2](#).

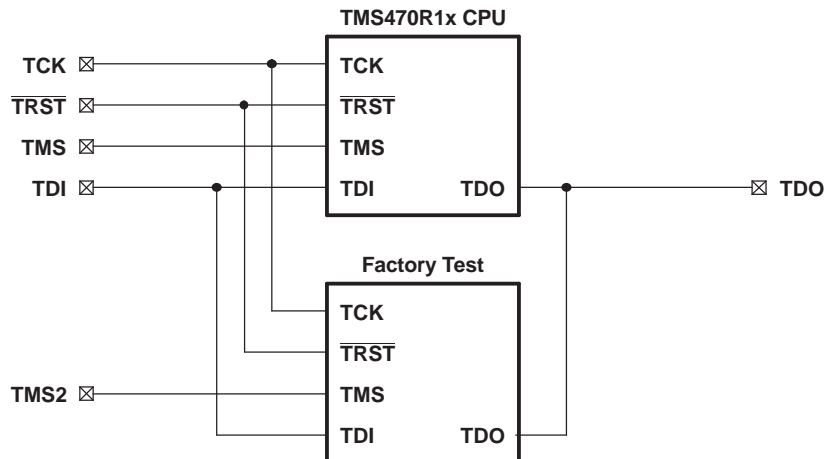

**Figure 2. JTAG Interface**

## Documentation Support

Extensive documentation supports all of the TMS470 microcontroller family generation of devices. The types of documentation available include: data sheets with design specifications; complete user's guides for all devices and development support tools; and hardware and software applications. Useful reference documentation includes:

- Bulletin
  - *TMS470 Microcontroller Family Product Bulletin* (literature number SPNB086)
- User's Guides
  - *TMS470R1x System Module Reference Guide* (literature number SPNU189)
  - *TMS470R1x General Purpose Input/Output (GPIO) Reference Guide* (literature number SPNU192)
  - *TMS470R1x Direct Memory Access (DMA) Controller Reference Guide* (literature number SPNU194)
  - *TMS470R1x Serial Peripheral Interface (SPI) Reference Guide* (literature number SPNU195)
  - *TMS470R1x Serial Communication Interface (SCI) Reference Guide* (literature number SPNU196)
  - *TMS470R1x Controller Area Network (CAN) Reference Guide* (literature number SPNU197)
  - *TMS470R1x High End Timer (HET) Reference Guide* (literature number SPNU199)
  - *TMS470R1x External Clock Prescale (ECP) Reference Guide* (literature number SPNU202)
  - *TMS470R1x MultiBuffered Analog to Digital (MibADC) Reference Guide* (literature number SPNU206)
  - *TMS470R1x ZeroPin Phase Locked Loop (ZPLL) Clock Module Reference Guide* (literature number SPNU212)
  - *TMS470R1x F05 Flash Reference Guide* (literature number SPNU213)
  - *TMS470R1x Class II Serial Interface B (C2S1b) Reference Guide* (literature number SPNU214)
  - *TMS470R1x Class II Serial Interface A (C2S1a) Reference Guide* (literature number SPNU218)
  - *TMS470R1x JTAG Security Module (JSM) Reference Guide* (literature number SPNU245)
  - *TMS470R1x Memory Security Module (MSM) Reference Guide* (literature number SPNU246)
  - *TMS470 Peripherals Overview Reference Guide* (literature number SPNU248)
- Errata Sheet
- *TMS470R1A288 TMS470 Microcontrollers Silicon Errata* (literature number SPNZ142)

### Device and Development-Support Tool Nomenclature

To designate the stages in the product development cycle, TI assigns prefixes to the part numbers of all DSP devices and support tools. Each DSP commercial family member has one of three prefixes: TMX, TMP, or TMS (e.g., **TMS470R1A288**). Texas Instruments recommends two of three possible prefix designators for its support tools: TMDX and TMDS. These prefixes represent evolutionary stages of product development from engineering prototypes (TMX/TMDX) through fully qualified production devices/tools (TMS/TMDS).

Device development evolutionary flow:

- TMX** Experimental device that is not necessarily representative of the final device's electrical specifications
- TMP** Final silicon die that conforms to the device's electrical specifications but has not completed quality and reliability verification
- TMS** Fully qualified production device

Support tool development evolutionary flow:

- TMDX** Development-support product that has not yet completed Texas Instruments internal qualification testing.
- TMDS** Fully qualified development-support product

TMX and TMP devices and TMDX development-support tools are shipped against the following disclaimer:

"Developmental product is intended for internal evaluation purposes."

TMS devices and TMDS development-support tools have been characterized fully, and the quality and reliability of the device have been demonstrated fully. TI's standard warranty applies.

Predictions show that prototype devices (TMX or TMP) have a greater failure rate than the standard production devices. Texas Instruments recommends that these devices not be used in any production system because their expected end-use failure rate still is undefined. Only qualified production devices are to be used.

[Figure 3](#) illustrates the numbering and symbol nomenclature for the TMS470R1x family.

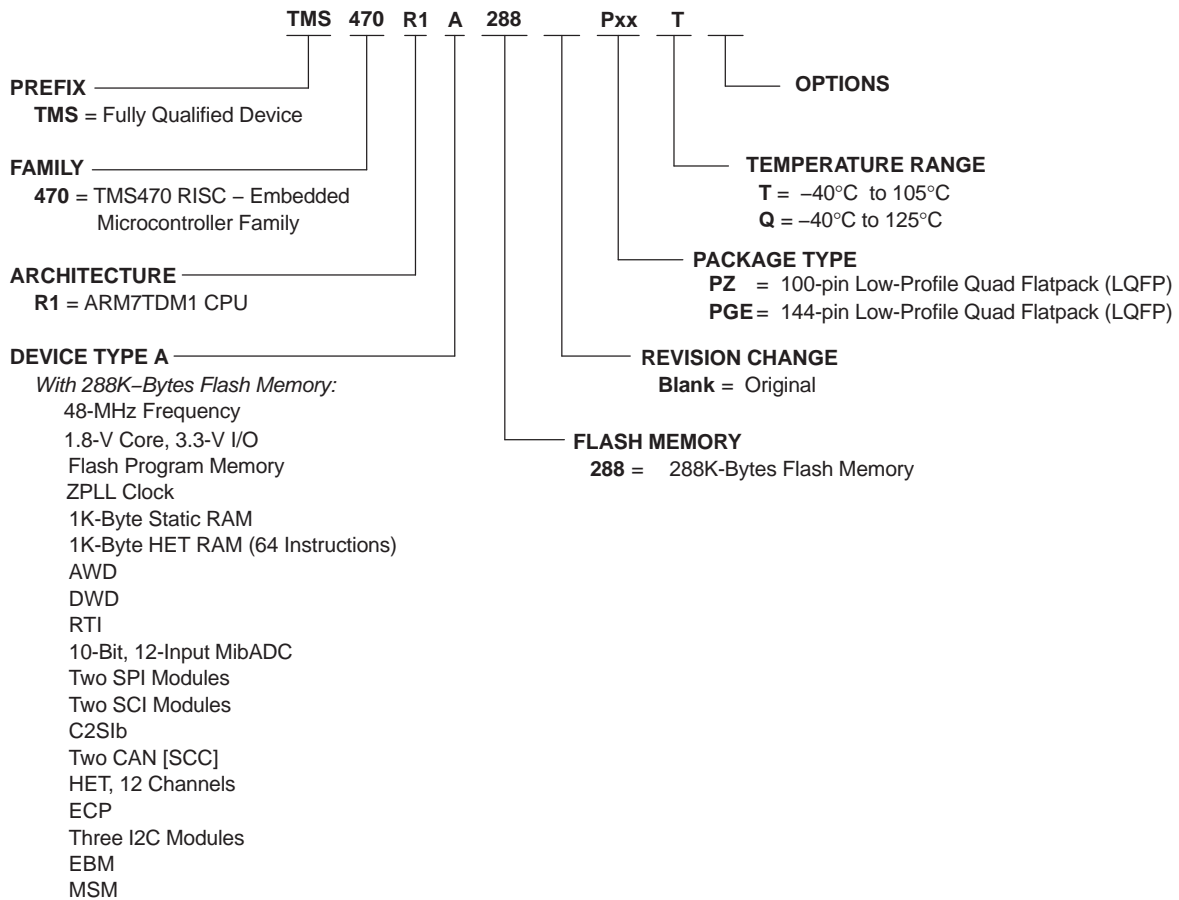
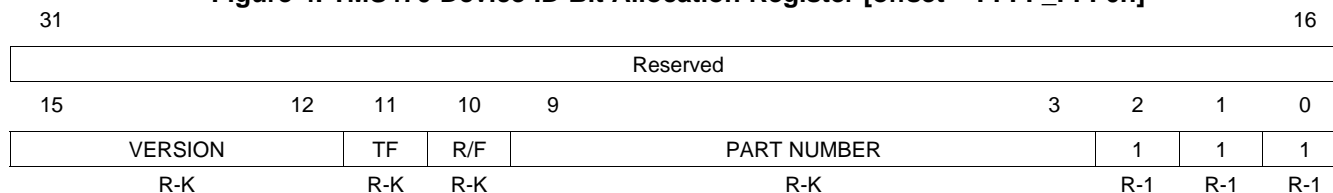

**Figure 3. TMS470R1x Family Nomenclature**

**Device Identification Code Register**

The device identification code register identifies the silicon version, the technology family (TF), a ROM or flash device, and an assigned device-specific part number (see Figure 4). The A288 device identification code register value is 0xn95F.

**Figure 4. TMS470 Device ID Bit Allocation Register [offset = FFFF\_FFF0h]**



**LEGEND:**

R = Read only, -K = Value constant after RESET; -n = Value after RESET

**Table 10. TMS470 Device ID Bit Allocation Register Field Descriptions**

Bit	Field	Value	Description
31-16	Reserved		Reads are undefined and writes have no effect.
15-12	VERSION		Silicon version (revision) bits These bits identify the silicon version of the device. Initial device version numbers start at 0000.
11	TF	0 1	Technology family bit This bit distinguishes the technology family core power supply: 3.3 V for F10/C10 devices 1.8 V for F05/C05 devices
10	R/F	0 1	ROM/flash bit This bit distinguishes between ROM and flash devices: Flash device ROM device
9-3	PART NUMBER		Device-specific part number bits These bits identify the assigned device-specific part number. The assigned device-specific part number for the A288 device is 0101011.
2-0	1		Mandatory High Bits 2, 1, and 0 are tied high by default.

## Device Electrical Specifications and Timing Parameters

### Absolute Maximum Ratings

over operating free-air temperature range, T version unless otherwise noted<sup>(1)</sup>

Supply voltage range:	$V_{CC}$ <sup>(2)</sup>	-0.3 V to 2.5 V
Supply voltage range:	$V_{CCIO}$ , $V_{CCAD}$ , $V_{CCP}$ (flash pump) <sup>(2)</sup>	-0.3 V to 4.1V
Input voltage range:	All 5 V- tolerant input pins	-0.3 V to 6.0V
	All other input pins	-0.3 V to 4.1V
Input clamp current:	All 5-V tolerant pins, $\overline{PORRST}$ , $\overline{TRST}$ , $\overline{TEST}$ , and TCK ( $V_I < 0$ )	-20 mA <sup>(3)</sup>
	ADIN[0:11] $I_{IK}$ ( $V_I < 0$ or $V_I > V_{CCAD}$ )	±10 mA
	All other pins $I_{IK}$ ( $V_I < 0$ or $V_I > V_{CCAD}$ )	±20 mA
Operating free-air temperature ranges, $T_A$	T version	-40°C to 105°C
	Q version	-40°C to 125°C
Operating junction temperature range, $T_J$		-40°C to 150°C
Storage temperature range, $T_{stg}$		-40°C to 150°C

(1) Stresses beyond those listed under "Absolute Maximum Ratings" may cause permanent damage to the device. These are stress ratings only, and functional operation of the device at these or any other conditions beyond those indicated under "Recommended Operating Conditions" is not implied. Exposure to absolute-maximum-rated conditions for extended periods may affect device reliability.

(2) All voltage values are with respect to their associated grounds.

(3) These pins do not have an internal clamp diode to a positive supply voltage.

### Device Recommended Operating Conditions<sup>(1)</sup>

		MIN	NOM	MAX	UNIT
$V_{CC}$	Digital logic supply voltage (Core)	1.71		2.05	V
$V_{CCIO}$	Digital logic supply voltage (I/O)	3		3.6	V
$V_{CCAD}$	MibADC supply voltage	3		3.6	V
$V_{CCP}$	Flash pump supply voltage	3		3.6	V
$V_{SS}$	Digital logic supply ground		0		V
$V_{SSAD}$	MibADC supply ground	-0.1		0.1	V
$T_A$	Operating free-air temperature	T version	-40	105	°C
		Q version	-40	125	
$T_J$	Operating junction temperature	-40		150	°C

(1) All voltages are with respect to  $V_{SS}$ , except  $V_{CCAD}$ , which is with respect to  $V_{SSAD}$ .

## Electrical Characteristics

over recommended operating free-air temperature range<sup>(1)</sup>

PARAMETER		TEST CONDITIONS	MIN	TYP	MAX	UNIT	
$V_{hys}$	Input hysteresis		0.15			V	
$V_{IL}$	Low-level input voltage	All inputs <sup>(2)</sup>	-0.3		0.8	V	
$V_{IH}$	High-level input voltage	All inputs	2		$V_{CCIO} + 0.3$	V	
$V_{th}$	Input threshold voltage	AWD only <sup>(3)</sup>	1.35		1.8	V	
$V_{OL}$	Low-level output voltage <sup>(4)</sup>	$I_{OL} = I_{OL} \text{ MAX}$			$0.2 V_{CCIO}$	V	
		$I_{OL} = 50 \mu\text{A}$			0.2		
$V_{OH}$	High-level output voltage <sup>(4)</sup>	$I_{OH} = I_{OH} \text{ MIN}$	$0.8 V_{CCIO}$			V	
		$I_{OH} = 50 \mu\text{A}$	$V_{CCIO} - 0.2$				
$I_{IC}$	Input clamp current (I/O pins) <sup>(5)</sup>	$V_I < V_{SSIO} - 0.3$ or $V_I > V_{CCIO} + 0.3$	-2		2	mA	
$I_I$	Input current (3.3 V input pins)	$I_{IL}$ Pulldown	$V_I = V_{SS}$	-1		1	$\mu\text{A}$
		$I_{IH}$ Pulldown	$V_I = V_{CCIO}$	5		40	
		$I_{IL}$ Pullup	$V_I = V_{SS}$	-40		-5	
		$I_{IH}$ Pullup	$V_I = V_{CCIO}$	-1		1	
		All other pins	No pullup or pulldown	-1		1	
	Input current (5 V tolerant input pins)	$V_I = V_{SS}$	-1		1	$\mu\text{A}$	
		$V_I = V_{CCIO}$	-1		1		
		$V_I = 5 \text{ V}$	0.5		20		
$V_I = 5.5 \text{ V}$		1		40			
$I_{OL}$	Low-level output current	CLKOUT, AWD, TDI, TDO, TMS, TMS2	$V_{OL} = V_{OL} \text{ MAX}$			8	mA
		RST				4	
		All other 3.3 V I/O <sup>(6)</sup>				2	
		5 V tolerant				4	
$I_{OH}$	High-level output current	CLKOUT, TDI, TDO, TMS, TMS2	$V_{OH} = V_{OH} \text{ MIN}$	-8			mA
		RST		-4			
		All other 3.3 V I/O <sup>(6)</sup>		-2			
		5 V tolerant		-4			

(1) Source currents (out of the device) are negative while sink currents (into the device) are positive.

(2) This does not apply to the PORRST pin. For PORRST exceptions, see the *RST and PORRST timings* section.

(3) These values help to determine the external RC network circuit. For more details, see the *TMS470R1x System Module Reference Guide* (literature number SPNU189).

(4)  $V_{OL}$  and  $V_{OH}$  are linear with respect to the amount of load current ( $I_{OL}/I_{OH}$ ) applied.

(5) Parameter does not apply to input-only or output-only pins.

(6) The 2 mA buffers on this device are called zero-dominant buffers. If two of these buffers are shorted together and one is outputting a low level and the other is outputting a high level, the resulting value will always be low.

**Electrical Characteristics (continued)**

over recommended operating free-air temperature range

PARAMETER		TEST CONDITIONS		MIN	TYP	MAX	UNIT	
I <sub>CC</sub>	V <sub>CC</sub> Digital supply current (operating mode)	SYSCLK = 48 MHz, ICLK = 24 MHz, V <sub>CC</sub> = 2.05 V				115	mA	
		SYSCLK = 24 MHz, ICLK = 15 MHz, V <sub>CC</sub> = 2.05 V				90	mA	
	V <sub>CC</sub> Digital supply current (standby mode) <sup>(7)(8)</sup>	OSCIN = 4MHz, V <sub>CC</sub> = 2.05 V	T version (105°C)			1	mA	
			Q version (125°C)			1.25		
V <sub>CC</sub> Digital supply current (halt mode) <sup>(7)(8)</sup>	V <sub>CC</sub> = 2.05 V	T version (105°C)				355	μA	
		Q version (125°C)				550		
I <sub>CCIO</sub>	V <sub>CCIO</sub> Digital supply current (operating mode)	No DC load, V <sub>CCIO</sub> = 3.6 V <sup>(9)</sup>				15	mA	
	V <sub>CCIO</sub> Digital supply current (standby mode) <sup>(8)</sup>	No DC load, V <sub>CCIO</sub> = 3.6 V <sup>(9)</sup>				10	μA	
	V <sub>CCIO</sub> Digital supply current (halt mode) <sup>(8)</sup>	30°C version, no DC load, V <sub>CCIO</sub> = 3.6 V <sup>(9)</sup>					5	μA
		No DC load, V <sub>CCIO</sub> = 3.6 V <sup>(9)</sup>					5	μA
I <sub>CCAD</sub>	V <sub>CCAD</sub> supply current (operating mode)	All frequencies, V <sub>CCAD</sub> = 3.6 V				25	mA	
	V <sub>CCAD</sub> supply current (standby mode)	No DC load, V <sub>CCAD</sub> = 3.6 V <sup>(9)</sup>				10	μA	
	V <sub>CCAD</sub> supply current (halt mode)	30°C version, no DC load, V <sub>CCAD</sub> = 3.6 V					5	μA
		V <sub>CCAD</sub> = 3.6 V					5	μA
I <sub>CCP</sub>	V <sub>CCP</sub> pump supply current	V <sub>CCP</sub> = 3.6 V read operation				60	mA	
		V <sub>CCP</sub> = 3.6 V program and erase				70	mA	
		V <sub>CCP</sub> = 3.6 V standby mode operation <sup>(7)</sup>				10	μA	
		30°C version, no DC load, V <sub>CCP</sub> = 3.6 V halt mode operation <sup>(7)</sup>					5	μA
		V <sub>CCP</sub> = 3.6 V halt mode operation <sup>(7)</sup>					5	μA
C <sub>I</sub>	Input capacitance				2		pF	
C <sub>O</sub>	Output capacitance				3		pF	

(7) For flash banks/pumps in sleep mode.

(8) For reduced power consumption in low power mode, CANSRX and CANSTX should be driven output LOW.

(9) I/O pins configured as inputs or outputs with no load. All pulldown inputs ≤ 0.2 V. All pullup inputs ≥ V<sub>CCIO</sub> - 0.2 V.

## Parameter Measurement Information

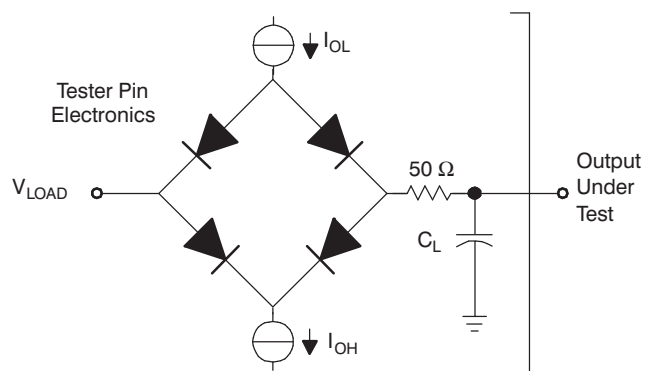

Where:  $I_{OL}$  =  $I_{OL}$  MAX for the respective pin<sup>(A)</sup>  
 $I_{OH}$  =  $I_{OH}$  MIN for the respective pin<sup>(A)</sup>  
 $V_{LOAD}$  = 1.5 V  
 $C_L$  = 150-pF typical load-circuit capacitance<sup>(B)</sup>

- A. For these values, see the "Electrical Characteristics over Recommended Operating Free-Air Temperature Range" table.
- B. All timing parameters measured using an external load capacitance of 150 pF unless otherwise noted.

**Figure 5. Test Load Circuit**

### Timing Parameter Symbology

Timing parameter symbols have been created in accordance with JEDEC Standard 100. To shorten the symbols, some of the pin names and other related terminology have been abbreviated as follows:

CM	Compaction, CMPCT	RD	Read
CO	CLKOUT	RST	Reset, $\overline{RST}$
ER	Erase	RX	SCInRX
ICLK	Interface clock	S	Slave mode
M	Master mode	SCC	SCInCLK
OSC, OSCI	OSCIN	SIMO	SPInSIMO
OSCO	OSCOOUT	SOMI	SPInSOMI
P	Program, PROG	SPC	SPInCLK
R	Ready	SYS	System clock
R0	Read margin 0, RDMRGN0	TX	SCInTX
R1	Read margin 1, RDMRGN1		

Lowercase subscripts and their meanings are:

a	access time	r	rise time
c	cycle time (period)	su	setup time
d	delay time	t	transition time
f	fall time	v	valid time
h	hold time	w	pulse duration (width)

The following additional letters are used with these meanings:

H	High	X	Unknown, changing, or don't care level
L	Low	Z	High impedance
V	Valid		

### External Reference Resonator/Crystal Oscillator Clock Option

The oscillator is enabled by connecting the appropriate fundamental 4-10 MHz resonator/crystal and load capacitors across the external OSCIN and OSCOUT pins as shown in Figure 6a. The oscillator is a single-stage inverter held in bias by an integrated bias resistor. This resistor is disabled during leakage test measurement and HALT mode. **TI strongly encourages each customer to submit samples of the device to the resonator/crystal vendors for validation.** The vendors are equipped to determine what load capacitors will best tune their resonator/crystal to the microcontroller device for optimum start-up and operation over temperature/voltage extremes.

An external oscillator source can be used by connecting a 1.8-V clock signal to the OSCIN pin and leaving the OSCOUT pin unconnected (open) as shown in Figure 6b.

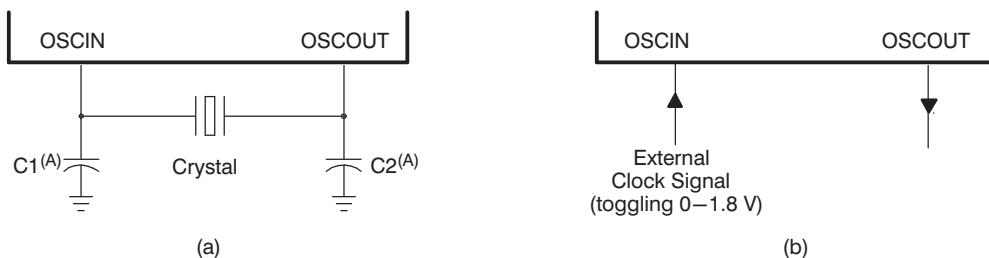

A. The values of C1 and C2 should be provided by the resonator/crystal vendor.

**Figure 6. Crystal/Clock Connection**

## ZPLL AND CLOCK SPECIFICATIONS

### Timing Requirements for ZPLL Circuits Enabled or Disabled

		MIN	TYP	MAX	UNIT
$f_{(OSC)}$	Input clock frequency	4		10	MHz
$t_{c(OOSC)}$	Cycle time, OSCIN	100			ns
$t_{w(OOSCIL)}$	Pulse duration, OSCIN low	15			ns
$t_{w(OOSCIH)}$	Pulse duration, OSCIN high	15			ns
$f_{(OSCRST)}$	OSC FAIL frequency <sup>(1)</sup>		53		kHz

(1) Causes a device reset (specifically a clock reset) by setting the RST OSC FAIL (GLBCTRL[15]) and the OSC FAIL flag (GLBSTAT[1]) bits equal to 1. For more detailed information on these bits and device resets, see the *TMS470R1x System Module Reference Guide* (literature number SPNU189).

### Switching Characteristics Over Recommended Operating Conditions for Clocks<sup>(1)(2)</sup>

PARAMETER		TEST CONDITIONS <sup>(3)</sup>	MIN	MAX	UNIT
$f_{(SYS)}$	System clock frequency <sup>(4)</sup>	Pipeline mode enabled		48	MHz
		Pipeline mode disabled		24	MHz
$f_{(CONFIG)}$	System clock frequency - flash config mode			24	MHz
$f_{(ICLK)}$	Interface clock frequency	Pipeline mode enabled		25	MHz
		Pipeline mode disabled		24	MHz
$f_{(ECLK)}$	External clock output frequency for ECP module	Pipeline mode enabled		25	MHz
		Pipeline mode disabled		24	MHz
$t_{c(SYS)}$	Cycle time, system clock	Pipeline mode enabled	20.8		ns
		Pipeline mode disabled	41.6		ns
$t_{c(CONFIG)}$	Cycle time, system clock - flash config mode		41.6		ns
$t_{c(ICLK)}$	Cycle time, interface clock	Pipeline mode enabled	40		ns
		Pipeline mode disabled	41.6		ns
$t_{c(ECLK)}$	Cycle time, ECP module external clock output	Pipeline mode enabled	40		ns
		Pipeline mode disabled	41.6		ns

(1)  $f_{(SYS)} = M \times f_{(OSC)} / R$ , where  $M = \{8\}$ ,  $R = \{1,2,3,4,5,6,7,8\}$  when PLLDIS = 0. R is the system-clock divider determined by the CLKDIVPRE [2:0] bits in the global control register (GLBCTRL[2:0]) and M is the PLL multiplier determined by the MULT4 bit also in the GLBCTRL register (GLBCTRL.3).

$f_{(SYS)} = f_{(OSC)} / R$ , where  $R = \{1,2,3,4,5,6,7,8\}$  when PLLDIS = 1.

$f_{(ICLK)} = f_{(SYS)} / X$ , where  $X = \{1,2,3,4,5,6,7,8,9,10,11,12,13,14,15,16\}$ . X is the interface clock divider ratio determined by the PCRO[4:1] bits in the SYS module.

(2)  $f_{(ECLK)} = f_{(ICLK)} / N$ , where  $N = \{1 \text{ to } 256\}$ . N is the ECP prescale value defined by the ECPCTRL[7:0] register bits in the ECP module.

(3) Pipeline mode enabled or disabled is determined by the ENPIPE bit (FMREGOPT[0]).

(4) Flash Vread must be set to 5 V to achieve maximum system clock frequency.

**Switching Characteristics Over Recommended Operating Conditions for External Clocks<sup>(1)(2)(3)</sup>**

(see [Figure 7](#) and [Figure 8](#))

PARAMETER		TEST CONDITIONS	MIN	MAX	UNIT
$t_{w(COL)}$	Pulse duration, CLKOUT low	SYSCLK or MCLK <sup>(4)</sup>	$0.5t_{c(SYS)} - t_f$		ns
		ICLK: X is even or 1 <sup>(5)</sup>	$0.5t_{c(ICLK)} - t_f$		
		ICLK: X is odd and not 1 <sup>(5)</sup>	$0.5t_{c(ICLK)} + 0.5t_{c(SYS)} - t_f$		
$t_{w(COH)}$	Pulse duration, CLKOUT high	SYSCLK or MCLK <sup>(4)</sup>	$0.5t_{c(SYS)} - t_r$		ns
		ICLK: X is even or 1 <sup>(5)</sup>	$0.5t_{c(ICLK)} - t_r$		
		ICLK: X is odd and not 1 <sup>(5)</sup>	$0.5t_{c(ICLK)} - 0.5t_{c(SYS)} - t_r$		
$t_{w(EOL)}$	Pulse duration, ECLK low	N is even and X is even or odd	$0.5t_{c(ECLK)} - t_f$		ns
		N is odd and X is even	$0.5t_{c(ECLK)} - t_f$		
		N is odd and X is odd and not 1	$0.5t_{c(ECLK)} + 0.5t_{c(SYS)} - t_f$		
$t_{w(EOH)}$	Pulse duration, ECLK high	N is even and X is even or odd	$0.5t_{c(ECLK)} - t_r$		ns
		N is odd and X is even	$0.5t_{c(ECLK)} - t_r$		
		N is odd and X is odd and not 1	$0.5t_{c(ECLK)} - 0.5t_{c(SYS)} - t_r$		

- (1) X = {1,2,3,4,5,6,7,8,9,10,11,12,13,14,15,16}. X is the interface clock divider ratio determined by the PCR0[4:1] bits in the SYS module.
- (2) N = {1 to 256}. N is the ECP prescale value defined by the ECPCTRL[7:0] register bits in the ECP module.
- (3) CLKOUT/ECLK pulse durations (low/high) are a function of the OSCIN pulse durations when PLLDIS is active.
- (4) Clock source bits are selected as either SYSCLK (CLKCNTL[6:5] = 11 binary) or MCLK (CLKCNTL[6:5] = 10 binary).
- (5) Clock source bits are selected as ICLK (CLKCNTL[6:5] = 01 binary).

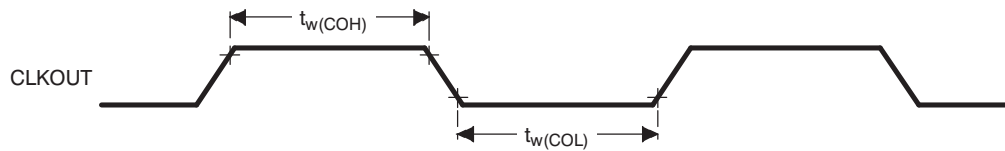

**Figure 7. CLKOUT Timing Diagram**

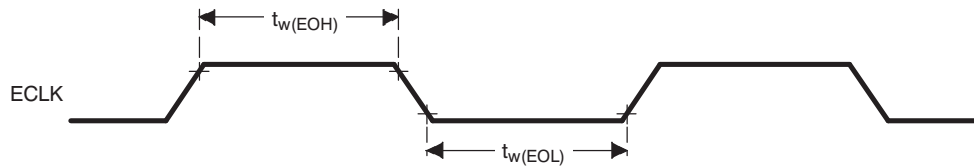

**Figure 8. ECLK Timing Diagram**

## RST AND PORRST TIMINGS

### Timing Requirements for PORRST

(see Figure 9)

		MIN	MAX	UNIT
$V_{CCPORL}$	$V_{CC}$ low supply level when $\overline{PORRST}$ must be active during power up		0.6	V
$V_{CCPORH}$	$V_{CC}$ high supply level when $\overline{PORRST}$ must remain active during power up and become active during power down	1.5		V
$V_{CCIOPORL}$	$V_{CCIO}$ low supply level when $\overline{PORRST}$ must be active during power up		1.1	V
$V_{CCIOPORH}$	$V_{CCIO}$ high supply level when $\overline{PORRST}$ must remain active during power up and become active during power down	2.75		V
$V_{IL}$	Low-level input voltage after $V_{CCIO} > V_{CCIOPORH}$		$0.2 V_{CCIO}$	V
$V_{IL(PORRST)}$	Low-level input voltage of $\overline{PORRST}$ before $V_{CCIO} > V_{CCIOPORL}$		0.5	V
$t_{su(PORRST)r}$	Setup time, $\overline{PORRST}$ active before $V_{CCIO} > V_{CCIOPORL}$ during power up	0		ms
$t_{su(VCCIO)r}$	Setup time, $V_{CCIO} > V_{CCIOPORL}$ before $V_{CC} > V_{CCPORL}$	0		ms
$t_{h(PORRST)r}$	Hold time, $\overline{PORRST}$ active after $V_{CC} > V_{CCPORH}$	1		ms
$t_{su(PORRST)f}$	Setup time, $\overline{PORRST}$ active before $V_{CC} \leq V_{CCPORH}$ during power down	8		$\mu$ s
$t_{h(PORRST)rio}$	Hold time, $\overline{PORRST}$ active after $V_{CC} > V_{CCIOPORH}$	1		ms
$t_{h(PORRST)d}$	Hold time, $\overline{PORRST}$ active after $V_{CC} < V_{CCPORL}$	0		ms
$t_{su(PORRST)fi}$	Setup time, $\overline{PORRST}$ active before $V_{CC} \leq V_{CCIOPORH}$ during power down	0		ns
$t_{su(VCCIO)f}$	Setup time, $V_{CC} < V_{CCPORL}$ before $V_{CCIO} < V_{CCIOPORL}$	0		ns

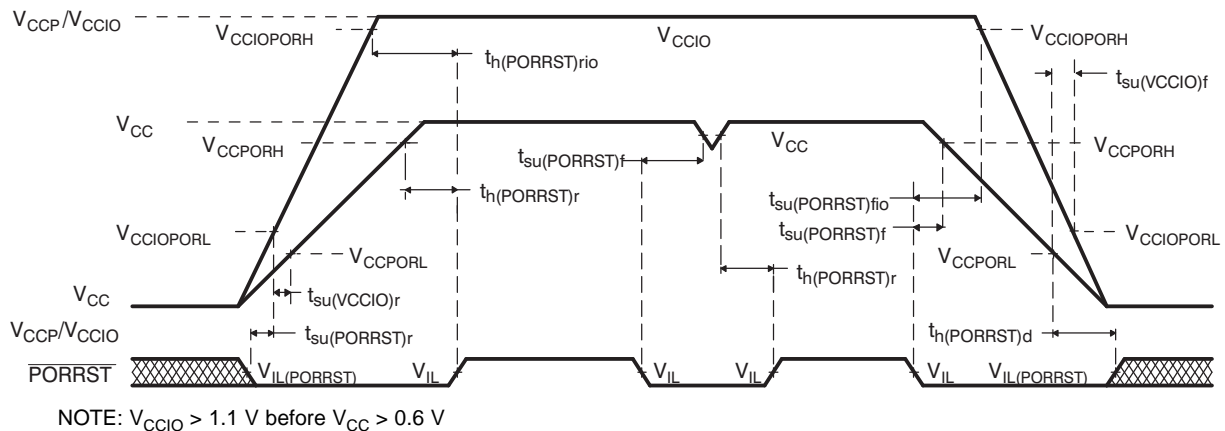

Figure 9.  $\overline{PORRST}$  Timing Diagram

### Switching Characteristics Over Recommended Operating Conditions for $\overline{RST}$ <sup>(1)</sup>

PARAMETER		MIN	MAX	UNIT
$t_{v(RST)}$	Valid time, $\overline{RST}$ active after $\overline{PORRST}$ inactive	$4112t_{c(OSC)}$		ns
	Valid time, $\overline{RST}$ active (all others)	$8t_{c(SYS)}$		
$t_{fsu}$	Flash start-up time, from $\overline{RST}$ inactive to fetch of first instruction from flash (flash pump stabilization time)	$670t_{c(OSC)}$		ns

(1) Specified values do NOT include rise/fall times. For rise and fall timings, see the "Switching Characteristics for Output Timings versus Load Capacitance" table.

**JTAG SCAN INTERFACE TIMING**

(JTAG Clock Specification 10-MHz and 50-pF Load on TDO Output)

		MIN	MAX	UNIT
$t_{c(JTAG)}$	Cycle time, JTAG low and high period	50		ns
$t_{su(TDI/TMS - TCKr)}$	Setup time, TDI, TMS before TCK rise (TCKr)	15		ns
$t_{h(TCKr - TDI/TMS)}$	Hold time, TDI, TMS after TCKr	15		ns
$t_{h(TCKf - TDO)}$	Hold time, TDO after TCKf	10		ns
$t_{d(TCKf - TDO)}$	Delay time, TDO valid after TCK fall (TCKf)		45	ns

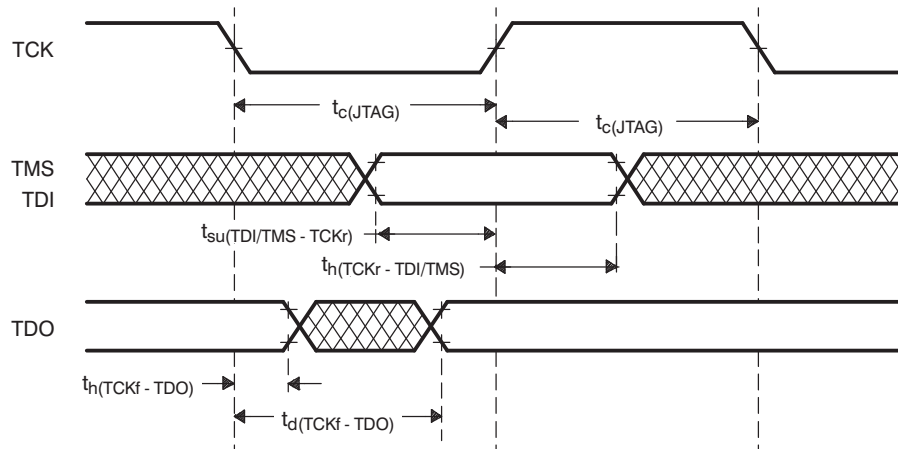

**Figure 10. JTAG Scan Timings**

## OUTPUT TIMINGS

### Switching Characteristics for Output Timings versus Load Capacitance ( $C_L$ )

(see Figure 11)

PARAMETER		MIN	MAX	UNIT	
$t_r$	Rise time, AWD, CLKOUT, TDI, TDO, TMS, TMS2	$C_L = 15$ pF	0.5	2.5	ns
		$C_L = 50$ pF	1.5	5.0	
		$C_L = 100$ pF	3	9.0	
		$C_L = 150$ pF	4.5	12.5	
$t_f$	Fall time, AWD, CLKOUT, TDI, TDO, TMS, TMS2	$C_L = 15$ pF	0.5	2.5	ns
		$C_L = 50$ pF	1.5	5.0	
		$C_L = 100$ pF	3	9.0	
		$C_L = 150$ pF	4.5	12.5	
$t_r$	Rise time, $\overline{RST}$	$C_L = 15$ pF	2.5	8	ns
		$C_L = 50$ pF	5	14	
		$C_L = 100$ pF	9	23	
		$C_L = 150$ pF	13	32	
$t_f$	Fall time, $\overline{RST}$	$C_L = 15$ pF	2.5	8	ns
		$C_L = 50$ pF	5	14	
		$C_L = 100$ pF	9	23	
		$C_L = 150$ pF	13	32	
$t_r$	Rise time, 4 mA, 5 V tolerant pins	$C_L = 15$ pF	3	10	ns
		$C_L = 50$ pF	3.5	12	
		$C_L = 100$ pF	7	21	
		$C_L = 150$ pF	9	28	
$t_f$	Fall time, 4 mA, 5 V tolerant pins	$C_L = 15$ pF	2	8	ns
		$C_L = 50$ pF	2.5	9	
		$C_L = 100$ pF	8	25	
		$C_L = 150$ pF	11	35	
$t_r$	Rise time, all other output pins	$C_L = 15$ pF	2.5	10	ns
		$C_L = 50$ pF	6.0	25	
		$C_L = 100$ pF	12	45	
		$C_L = 150$ pF	18	65	
$t_f$	Fall time, all other output pins	$C_L = 15$ pF	3	10	ns
		$C_L = 50$ pF	8.5	25	
		$C_L = 100$ pF	16	45	
		$C_L = 150$ pF	23	65	

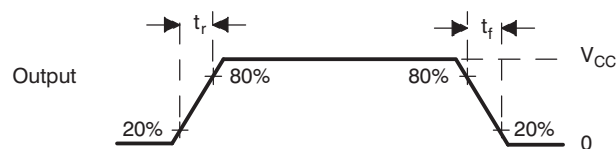

Figure 11. CMOS-Level Outputs

## INPUT TIMINGS

### Timing Requirements for Input Timings<sup>(1)</sup>

(see Figure 12)

		MIN	MAX	UNIT
$t_{pw}$	Input minimum pulse width	$t_{c(ICKL)} + 10$		ns

(1)  $t_{c(ICKL)}$  = interface clock cycle time =  $1 / f_{(ICKL)}$

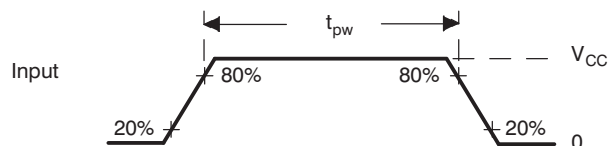

Figure 12. CMOS-Level Inputs

## FLASH TIMINGS

### Timing Requirements for Program Flash<sup>(1)</sup>

		MIN	TYP	MAX	UNIT
$t_{prog(16-bit)}$	Half word (16-bit) programming time	4	16	200	$\mu$ s
$t_{prog(Total)}$	288K-byte programming time <sup>(2)</sup>		2	8	s
$t_{erase(sector)}$	Sector erase time		1.7		s
$t_{wec}$	Write/erase cycles at $T_A = -40^{\circ}\text{C}$ to $125^{\circ}\text{C}$	50000			cycles
$t_{fp(RST)}$	Flash pump settling time from $\overline{\text{RST}}$ to SLEEP		$134t_{c(SYS)}$		ns
$t_{fp(SLEEP)}$	Initial flash pump settling time from SLEEP to STANDBY		$134t_{c(SYS)}$		
$t_{fp(STANDBY)}$	Initial flash pump settling time from STANDBY to ACTIVE		$67t_{c(SYS)}$		

(1) For more detailed information on the flash core sectors, see the *flash program and erase* section of this data sheet.

(2) The 288K-byte programming time includes overhead of state machine.

## SPIn MASTER MODE TIMING PARAMETERS

### SPIn Master Mode External Timing Parameters

(CLOCK PHASE = 0, SPInCLK = output, SPInSIMO = output, and SPInSOMI = input)<sup>(1)(2)(3)</sup> (see Figure 13)

NO.			MIN	MAX	UNIT
1	$t_{c(SPC)M}$	Cycle time, SPInCLK <sup>(4)</sup>	100	$256t_{c(ICK)M}$	ns
2 <sup>(5)</sup>	$t_{w(SPCH)M}$	Pulse duration, SPInCLK high (clock polarity = 0)	$0.5t_{c(SPC)M} - t_f$	$0.5t_{c(SPC)M} + 5$	ns
	$t_{w(SPCL)M}$	Pulse duration, SPInCLK low (clock polarity = 1)	$0.5t_{c(SPC)M} - t_f$	$0.5t_{c(SPC)M} + 5$	
3 <sup>(5)</sup>	$t_{w(SPCL)M}$	Pulse duration, SPInCLK low (clock polarity = 0)	$0.5t_{c(SPC)M} - t_f$	$0.5t_{c(SPC)M} + 5$	ns
	$t_{w(SPCH)M}$	Pulse duration, SPInCLK high (clock polarity = 1)	$0.5t_{c(SPC)M} - t_f$	$0.5t_{c(SPC)M} + 5$	
4 <sup>(5)</sup>	$t_{d(SPCH-SIMO)M}$	Delay time, SPInCLK high to SPInSIMO valid (clock polarity = 0)		10	ns
	$t_{d(SPCL-SIMO)M}$	Delay time, SPInCLK low to SPInSIMO valid (clock polarity = 1)		10	
5 <sup>(5)</sup>	$t_{v(SPCL-SIMO)M}$	Valid time, SPInSIMO data valid after SPInCLK low (clock polarity = 0)	$t_{c(SPC)M} - 5 - t_f$		ns
	$t_{v(SPCH-SIMO)M}$	Valid time, SPInSIMO data valid after SPInCLK high (clock polarity = 1)	$t_{c(SPC)M} - 5 - t_f$		
6 <sup>(5)</sup>	$t_{su(SOMI-SPCL)M}$	Setup time, SPInSOMI before SPInCLK low (clock polarity = 0)	6		ns
	$t_{su(SOMI-SPCH)M}$	Setup time, SPInSOMI before SPInCLK high (clock polarity = 1)	6		
7 <sup>(5)</sup>	$t_{v(SPCL-SOMI)M}$	Valid time, SPInSOMI data valid after SPInCLK low (clock polarity = 0)	4		ns
	$t_{v(SPCH-SOMI)M}$	Valid time, SPInSOMI data valid after SPInCLK high (clock polarity = 1)	4		

(1) The MASTER bit (SPInCTRL2.3) is set and the CLOCK PHASE bit (SPInCTRL2[0]) is cleared.

(2)  $t_{c(ICK)M}$  = interface clock cycle time =  $1 / f_{(ICK)}$

(3) For rise and fall timings, see the "Switching Characteristics for Output Timings versus Load Capacitance" table.

(4) When the SPI is in master mode, the following must be true:

For PS values from 1 to 255:  $t_{c(SPC)M} \geq (PS + 1)t_{c(ICK)M} \geq 100$  ns, where PS is the prescale value set in the SPInCTL1[12:5] register bits.

For PS values of 0:  $t_{c(SPC)M} = 2t_{c(ICK)M} \geq 100$  ns.

(5) The active edge of the SPInCLK signal referenced is controlled by the CLOCK POLARITY bit (SPInCTRL2[1]).

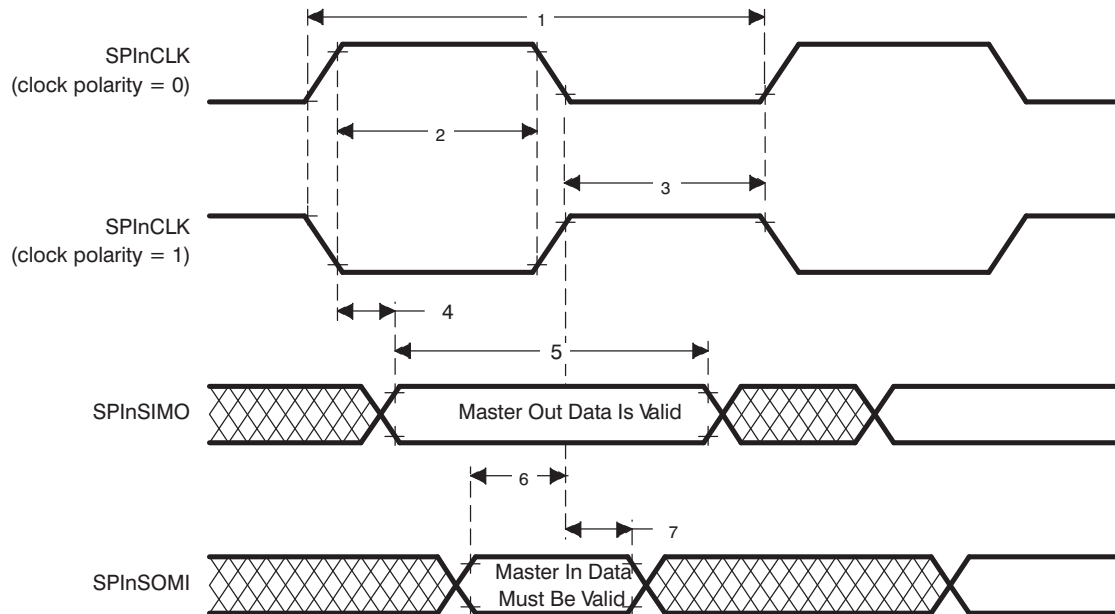

Figure 13. SPIn Master Mode External Timing (CLOCK PHASE = 0)

**SPI Master Mode External Timing Parameters**

(CLOCK PHASE = 1, SPInCLK = output, SPInSIMO = output, and SPInSOMI = input)<sup>(1)(2)(3)</sup> (see Figure 14)

NO.			MIN	MAX	UNIT
1	$t_{c(SPC)M}$	Cycle time, SPInCLK <sup>(4)</sup>	100	$256t_{c(ICLK)}$	ns
2 <sup>(5)</sup>	$t_{w(SPCH)M}$	Pulse duration, SPInCLK high (clock polarity = 0)	$0.5t_{c(SPC)M} - t_r$	$0.5t_{c(SPC)M} + 5$	ns
	$t_{w(SPCL)M}$	Pulse duration, SPInCLK low (clock polarity = 1)	$0.5t_{c(SPC)M} - t_f$	$0.5t_{c(SPC)M} + 5$	
3 <sup>(5)</sup>	$t_{w(SPCL)M}$	Pulse duration, SPInCLK low (clock polarity = 0)	$0.5t_{c(SPC)M} - t_f$	$0.5t_{c(SPC)M} + 5$	ns
	$t_{w(SPCH)M}$	Pulse duration, SPInCLK high (clock polarity = 1)	$0.5t_{c(SPC)M} - t_r$	$0.5t_{c(SPC)M} + 5$	
4 <sup>(5)</sup>	$t_{v(SIMO-SPCH)M}$	Valid time, SPInCLK high after SPInSIMO data valid (clock polarity = 0)	$0.5t_{c(SPC)M} - 12$		ns
	$t_{v(SIMO-SPCL)M}$	Valid time, SPInCLK low after SPInSIMO data valid (clock polarity = 1)	$0.5t_{c(SPC)M} - 10$		
5 <sup>(5)</sup>	$t_{v(SPCH-SIMO)M}$	Valid time, SPInSIMO data valid after SPInCLK high (clock polarity = 0)	$0.5t_{c(SPC)M} - 5 - t_r$		ns
	$t_{v(SPCL-SIMO)M}$	Valid time, SPInSIMO data valid after SPInCLK low (clock polarity = 1)	$0.5t_{c(SPC)M} - 5 - t_f$		
6 <sup>(5)</sup>	$t_{su(SOMI-SPCH)M}$	Setup time, SPInSOMI before SPInCLK high (clock polarity = 0)	6		ns
	$t_{su(SOMI-SPCL)M}$	Setup time, SPInSOMI before SPInCLK low (clock polarity = 1)	6		
7 <sup>(5)</sup>	$t_{v(SPCH-SOMI)M}$	Valid time, SPInSOMI data valid after SPInCLK high (clock polarity = 0)	4		ns
	$t_{v(SPCL-SOMI)M}$	Valid time, SPInSOMI data valid after SPInCLK low (clock polarity = 1)	4		

- (1) The MASTER bit (SPInCTRL2.3) is set and the CLOCK PHASE bit (SPInCTRL2[0]) is set.
- (2)  $t_{c(ICLK)}$  = interface clock cycle time =  $1 / f_{(ICLK)}$
- (3) For rise and fall timings, see the "Switching Characteristics for Output Timings versus Load Capacitance" table.
- (4) When the SPI is in master mode, the following must be true:  
For PS values from 1 to 255:  $t_{c(SPC)M} \geq (PS + 1)t_{c(ICLK)} \geq 100$  ns, where PS is the prescale value set in the SPInCTL1[12:5] register bits.  
For PS values of 0:  $t_{c(SPC)M} = 2t_{c(ICLK)} \geq 100$  ns.
- (5) The active edge of the SPInCLK signal referenced is controlled by the CLOCK POLARITY bit (SPInCTRL2[1]).

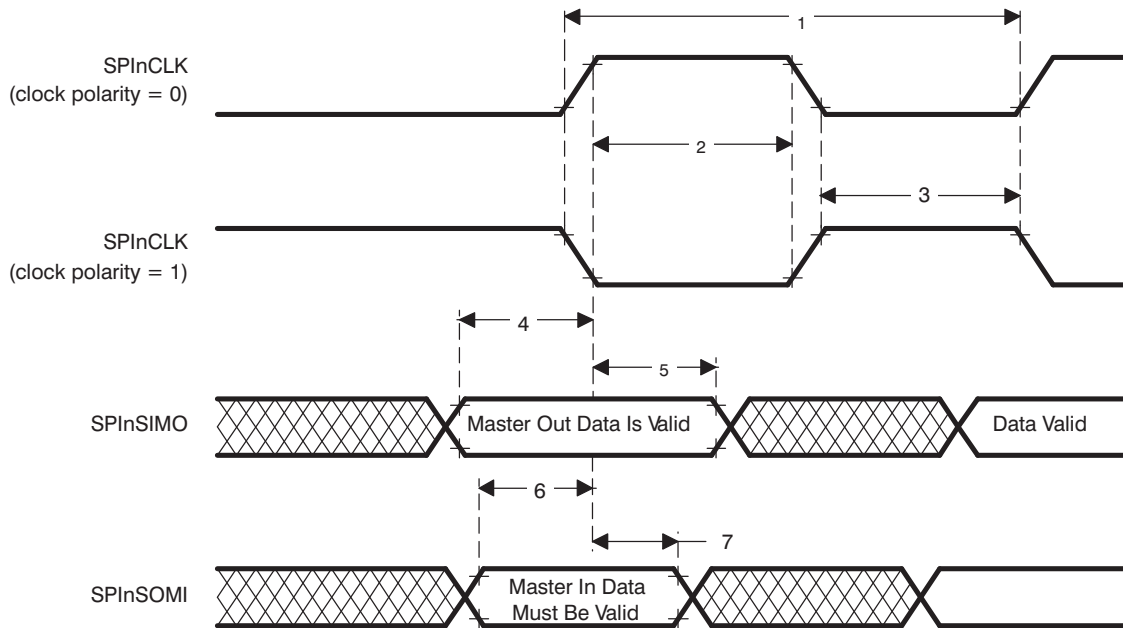

**Figure 14. SPI Master Mode External Timing (CLOCK PHASE = 1)**

## SPIn SLAVE MODE TIMING PARAMETERS

### SPIn Slave Mode External Timing Parameters

(CLOCK PHASE = 0, SPInCLK = input, SPInSIMO = input, and SPInSOMI = output)<sup>(1)(2)(3)(4)</sup> (see [Figure 15](#))

NO.			MIN	MAX	UNIT
1	$t_{c(SPC)S}$	Cycle time, SPInCLK <sup>(5)</sup>	100	$256t_{c(ICLK)}$	ns
2 <sup>(6)</sup>	$t_{w(SPCH)S}$	Pulse duration, SPInCLK high (clock polarity = 0)	$0.5t_{c(SPC)S} - 0.25t_{c(ICLK)}$	$0.5t_{c(SPC)S} + 0.25t_{c(ICLK)}$	ns
	$t_{w(SPCL)S}$	Pulse duration, SPInCLK low (clock polarity = 1)	$0.5t_{c(SPC)S} - 0.25t_{c(ICLK)}$	$0.5t_{c(SPC)S} + 0.25t_{c(ICLK)}$	
3 <sup>(6)</sup>	$t_{w(SPCL)S}$	Pulse duration, SPInCLK low (clock polarity = 0)	$0.5t_{c(SPC)S} - 0.25t_{c(ICLK)}$	$0.5t_{c(SPC)S} + 0.25t_{c(ICLK)}$	ns
	$t_{w(SPCH)S}$	Pulse duration, SPInCLK high (clock polarity = 1)	$0.5t_{c(SPC)S} - 0.25t_{c(ICLK)}$	$0.5t_{c(SPC)S} + 0.25t_{c(ICLK)}$	
4 <sup>(6)</sup>	$t_{d(SPCH-SOMI)S}$	Delay time, SPInCLK high to SPInSOMI valid (clock polarity = 0)		$6 + t_r$	ns
	$t_{d(SPCL-SOMI)S}$	Delay time, SPInCLK low to SPInSOMI valid (clock polarity = 1)		$6 + t_f$	
5 <sup>(6)</sup>	$t_{v(SPCH-SOMI)S}$	Valid time, SPInSOMI data valid after SPInCLK high (clock polarity = 0)	$t_{c(SPC)S} - 6 - t_r$		ns
	$t_{v(SPCL-SOMI)S}$	Valid time, SPInSOMI data valid after SPInCLK low (clock polarity = 1)	$t_{c(SPC)S} - 6 - t_f$		
6 <sup>(6)</sup>	$t_{su(SIMO-SPCL)S}$	Setup time, SPInSIMO before SPInCLK low (clock polarity = 0)	6		ns
	$t_{su(SIMO-SPCH)S}$	Setup time, SPInSIMO before SPInCLK high (clock polarity = 1)	6		
7 <sup>(6)</sup>	$t_{v(SPCL-SIMO)S}$	Valid time, SPInSIMO data valid after SPInCLK low (clock polarity = 0)	6		ns
	$t_{v(SPCH-SIMO)S}$	Valid time, SPInSIMO data valid after SPInCLK high (clock polarity = 1)	6		

- (1) The MASTER bit (SPInCTRL2.3) is cleared and the CLOCK PHASE bit (SPInCTRL2[0]) is cleared.
- (2) If the SPI is in slave mode, the following must be true:  $t_{c(SPC)S} \geq (PS + 1)t_{c(ICLK)}$ , where PS = prescale value set in SPInCTL1[12:5].
- (3) For rise and fall timings, see the "Switching Characteristics for Output Timings versus Load Capacitance" table.
- (4)  $t_{c(ICLK)}$  = interface clock cycle time =  $1/f_{ICLK}$
- (5) When the SPIn is in slave mode, the following must be true:  
 For PS values from 1 to 255:  $t_{c(SPC)S} \geq (PS + 1)t_{c(ICLK)} \geq 100$  ns, where PS is the prescale value set in the SPInCTL1[12:5] register bits.  
 For PS values of 0:  $t_{c(SPC)S} = 2t_{c(ICLK)} \geq 100$  ns.
- (6) The active edge of the SPInCLK signal referenced is controlled by the CLOCK POLARITY bit (SPInCTRL2[1]).

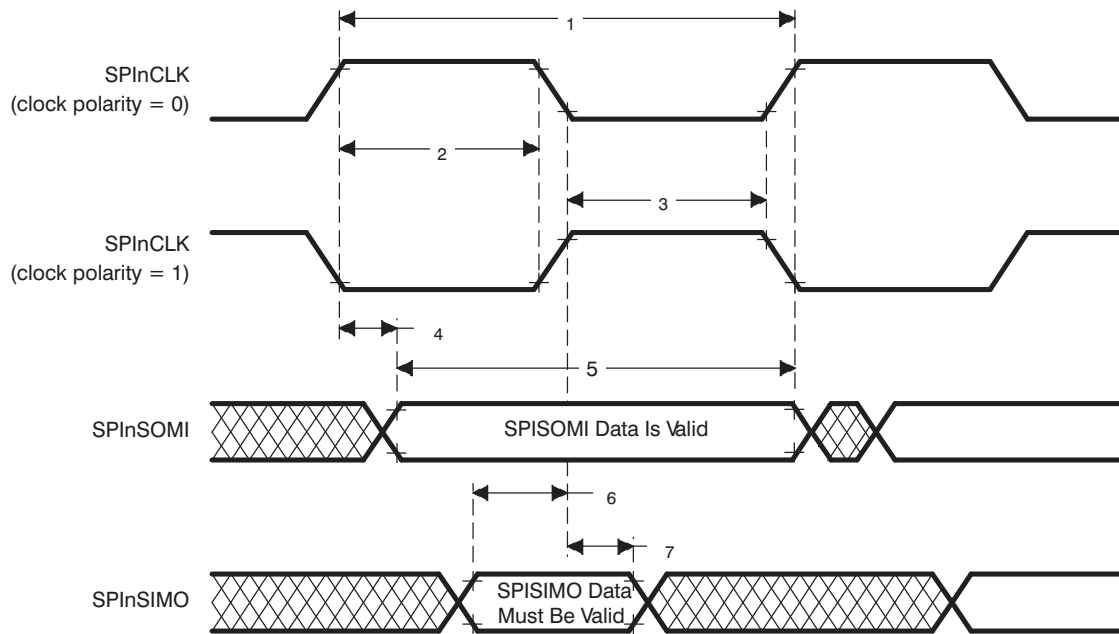

Figure 15. SPIn Slave Mode External Timing (CLOCK PHASE = 0)

### SPIn Slave Mode External Timing Parameters

(CLOCK PHASE = 1, SPInCLK = input, SPInSIMO = input, and SPInSOMI = output)<sup>(1)(2)(3)(4)</sup> (see Figure 16)

NO.			MIN	MAX	UNIT
1	$t_{c(SPC)S}$	Cycle time, SPInCLK <sup>(5)</sup>	100	$256t_{c(ICLK)}$	ns
2 <sup>(6)</sup>	$t_{w(SPCH)S}$	Pulse duration, SPInCLK high (clock polarity = 0)	$0.5t_{c(SPC)S} - 0.25t_{c(ICLK)}$	$0.5t_{c(SPC)S} + 0.25t_{c(ICLK)}$	ns
	$t_{w(SPCL)S}$	Pulse duration, SPInCLK low (clock polarity = 1)	$0.5t_{c(SPC)S} - 0.25t_{c(ICLK)}$	$0.5t_{c(SPC)S} + 0.25t_{c(ICLK)}$	
3 <sup>(6)</sup>	$t_{w(SPCL)S}$	Pulse duration, SPInCLK low (clock polarity = 0)	$0.5t_{c(SPC)S} - 0.25t_{c(ICLK)}$	$0.5t_{c(SPC)S} + 0.25t_{c(ICLK)}$	ns
	$t_{w(SPCH)S}$	Pulse duration, SPInCLK high (clock polarity = 1)	$0.5t_{c(SPC)S} - 0.25t_{c(ICLK)}$	$0.5t_{c(SPC)S} + 0.25t_{c(ICLK)}$	
4 <sup>(6)</sup>	$t_{v(SOMI-SPCH)S}$	Valid time, SPInCLK high after SPInSOMI data valid (clock polarity = 0)	$0.5t_{c(SPC)S} - 6 - t_r$		ns
	$t_{v(SOMI-SPCL)S}$	Valid time, SPInCLK low after SPInSOMI data valid (clock polarity = 1)	$0.5t_{c(SPC)S} - 6 - t_r$		
5 <sup>(6)</sup>	$t_{v(SPCH-SOMI)S}$	Valid time, SPInSOMI data valid after SPInCLK high (clock polarity = 0)	$0.5t_{c(SPC)S} - 6 - t_r$		ns
	$t_{v(SPCL-SOMI)S}$	Valid time, SPInSOMI data valid after SPInCLK low (clock polarity = 1)	$0.5t_{c(SPC)S} - 6 - t_r$		
6 <sup>(6)</sup>	$t_{su(SIMO-SPCH)S}$	Setup time, SPInSIMO before SPInCLK high (clock polarity = 0)	6		ns
	$t_{su(SIMO-SPCL)S}$	Setup time, SPInSIMO before SPInCLK low (clock polarity = 1)	6		
7 <sup>(6)</sup>	$t_{v(SPCH-SIMO)S}$	Valid time, SPInSIMO data valid after SPInCLK high (clock polarity = 0)	6		ns
	$t_{v(SPCL-SIMO)S}$	Valid time, SPInSIMO data valid after SPInCLK low (clock polarity = 1)	6		

- (1) The MASTER bit (SPInCTRL2.3) is cleared and the CLOCK PHASE bit (SPInCTRL2[0]) is set.
- (2) If the SPI is in slave mode, the following must be true:  $t_{c(SPC)S} \geq (PS + 1) t_{c(ICLK)}$ , where PS = prescale value set in SPInCTL1[12:5].
- (3) For rise and fall timings, see the "Switching Characteristics for Output Timings versus Load Capacitance" table.
- (4)  $t_{c(ICLK)}$  = interface clock cycle time =  $1 / f_{ICLK}$
- (5) When the SPIn is in slave mode, the following must be true:  
For PS values from 1 to 255:  $t_{c(SPC)S} \geq (PS + 1)t_{c(ICLK)} \geq 100$  ns, where PS is the prescale value set in the SPInCTL1[12:5] register bits.  
For PS values of 0:  $t_{c(SPC)S} = 2t_{c(ICLK)} \geq 100$  ns.
- (6) The active edge of the SPInCLK signal referenced is controlled by the CLOCK POLARITY bit (SPInCTRL2[1]).

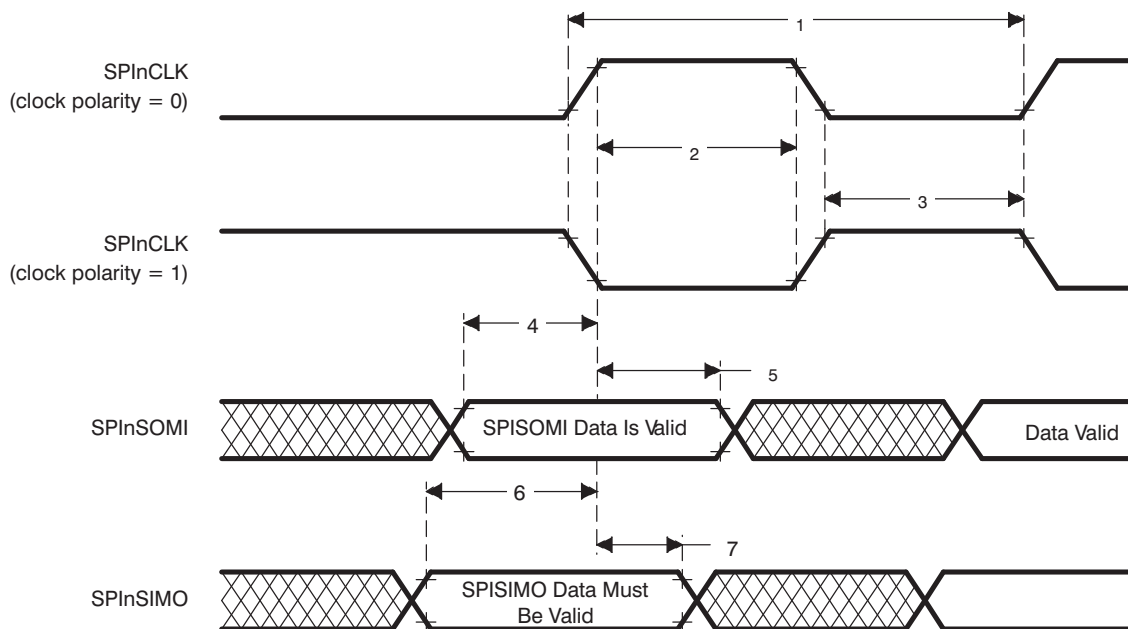

Figure 16. SPIn Slave Mode External Timing (CLOCK PHASE = 1)

**SCI<sub>n</sub> ISOSYNCHRONOUS MODE TIMINGS INTERNAL CLOCK**

**Timing Requirements for Internal Clock SCI<sub>n</sub> Isosynchronous Mode<sup>(1)(2)(3)</sup>**

(see Figure 18)

		(BAUD + 1) IS EVEN OR BAUD = 0		(BAUD + 1) IS ODD AND BAUD ≠ 0		UNI T
		MIN	MAX	MIN	MAX	
$t_{c(SCC)}$	Cycle time, SCI <sub>n</sub> CLK	$2t_{c(ICLK)}$	$2^{24} t_{c(ICLK)}$	$3t_{c(ICLK)}$	$(2^{24} - 1) t_{c(ICLK)}$	ns
$t_w(SCCL)$	Pulse duration, SCI <sub>n</sub> CLK low	$0.5t_{c(SCC)} - t_f$	$0.5t_{c(SCC)} + 5$	$0.5t_{c(SCC)} + 0.5t_{c(ICLK)} - t_f$	$0.5t_{c(SCC)} + 0.5t_{c(ICLK)}$	ns
$t_w(SCCH)$	Pulse duration, SCI <sub>n</sub> CLK high	$0.5t_{c(SCC)} - t_f$	$0.5t_{c(SCC)} + 5$	$0.5t_{c(SCC)} - 0.5t_{c(ICLK)} - t_f$	$0.5t_{c(SCC)} - 0.5t_{c(ICLK)}$	ns
$t_d(SCCH-TXV)$	Delay time, SCI <sub>n</sub> CLK high to SCI <sub>n</sub> TX valid		10		10	ns
$t_v(TX)$	Valid time, SCI <sub>n</sub> TX data after SCI <sub>n</sub> CLK low	$t_{c(SCC)} - 10$		$t_{c(SCC)} - 10$		ns
$t_{su}(RX-SCCL)$	Setup time, SCI <sub>n</sub> RX before SCI <sub>n</sub> CLK low	$t_{c(ICLK)} + t_f + 20$		$t_{c(ICLK)} + t_f + 20$		ns
$t_v(SCCL-RX)$	Valid time, SCI <sub>n</sub> RX data after SCI <sub>n</sub> CLK low	$-t_{c(ICLK)} + t_f + 20$		$-t_{c(ICLK)} + t_f + 20$		ns

(1) BAUD = 24-bit concatenated value formed by the SCI[H,M,L]BAUD registers.

(2)  $t_{c(ICLK)}$  = interface clock cycle time =  $1/f_{(ICLK)}$

(3) For rise and fall timings, see the "Switching Characteristics for Output Timings versus Load Capacitance" table.

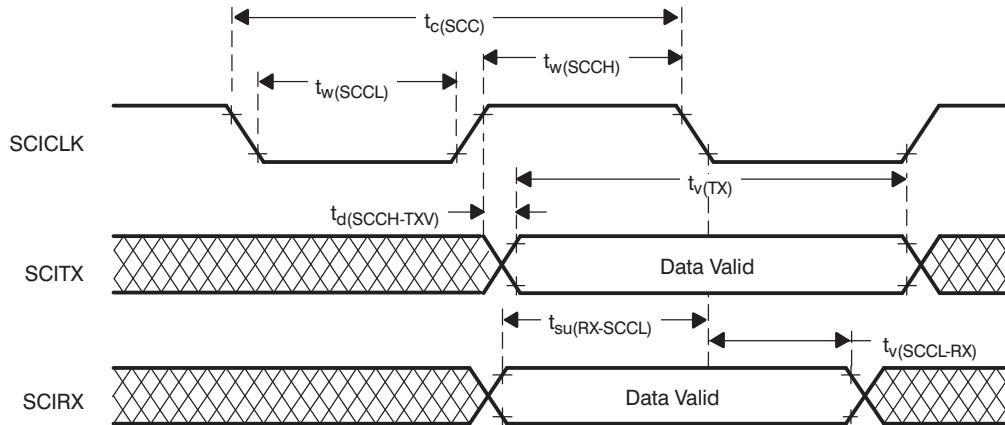

A. Data transmission / reception characteristics for isosynchronous mode with external clocking are similar to the asynchronous mode. Data transmission occurs on the SCICLK rising edge, and data reception occurs on the SCICLK falling edge.

**Figure 17. SCI<sub>n</sub> Isosynchronous Mode Timing Diagram for External Clock**

## SCIn ISOSYNCHRONOUS MODE TIMINGS EXTERNAL CLOCK

### Timing Requirements for External Clock SCIn Isosynchronous Mode<sup>(1)(2)</sup>

(see Figure 17)

		MIN	MAX	UNIT
$t_{c(SCC)}$	Cycle time, SCInCLK <sup>(3)</sup>	$8t_{c(ICKL)}$		ns
$t_{w(SCCH)}$	Pulse duration, SCInCLK high	$0.5t_{c(SCC)} - 0.25t_{c(ICKL)}$	$0.5t_{c(SCC)} + 0.25t_{c(ICKL)}$	ns
$t_{w(SCCL)}$	Pulse duration, SCInCLK low	$0.5t_{c(SCC)} - 0.25t_{c(ICKL)}$	$0.5t_{c(SCC)} + 0.25t_{c(ICKL)}$	ns
$t_{d(SCCH-TXV)}$	Delay time, SCInCLK high to SCInTX valid		$2t_{c(ICKL)} + 12 + t_r$	ns
$t_{v(TX)}$	Valid time, SCInTX data after SCInCLK low	$2t_{c(SCC)} - 10$		ns
$t_{su(RX-SCCL)}$	Setup time, SCInRX before SCInCLK low	0		ns
$t_{v(SCCL-RX)}$	Valid time, SCInRX data after SCInCLK low	$2t_{c(ICKL)} + 10$		ns

(1)  $t_{c(ICKL)}$  = interface clock cycle time =  $1 / f_{(ICKL)}$

(2) For rise and fall timings, see the "Switching Characteristics for Output Timings versus Load Capacitance" table.

(3) When driving an external SCInCLK, the following must be true:  $t_{c(SCC)} \geq 8t_{c(ICKL)}$ .

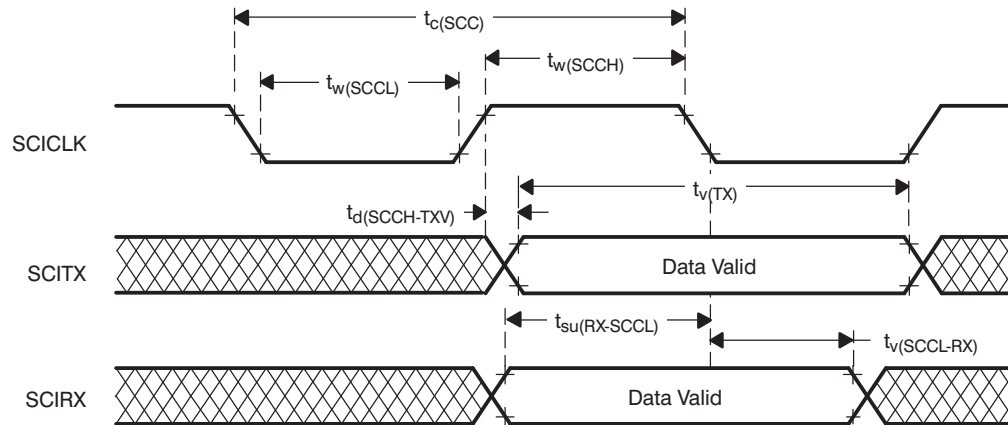

- A. Data transmission/reception characteristics for isosynchronous mode with internal clocking are similar to the asynchronous mode. Data transmission occurs on the SCICLK rising edge, and data reception occurs on the SCICLK falling edge.

**Figure 18. SCIn Isosynchronous Mode Timing Diagram for Internal Clock**

**I2C TIMING**

Table 11 below assumes testing over recommended operating conditions.

**Table 11. I2C Signals (SDA and SCL) Switching Characteristics<sup>(1)</sup>**

PARAMETER	STANDARD MODE	FAST MODE		UNIT		
		MIN	MAX		MIN	MAX
$t_{c(I2CCLK)}$	Cycle time, I2C module clock	75	150	75	150	ns
$t_{c(SCL)}$	Cycle time, SCL	10		2.5		$\mu$ s
$t_{su(SCLH-SDAL)}$	Setup time, SCL high before SDA low (for a repeated START condition)	4.7		0.6		$\mu$ s
$t_{h(SCLL-SDAL)}$	Hold time, SCL low after SDA low (for a repeated START condition)	4		0.6		$\mu$ s
$t_{w(SCLL)}$	Pulse duration, SCL low	4.7		1.3		$\mu$ s
$t_{w(SCLH)}$	Pulse duration, SCL high	4		0.6		$\mu$ s
$t_{su(SDA-SCLH)}$	Setup time, SDA valid before SCL high	250		100		ns
$t_{h(SDA-SCLL)}$	Hold time, SDA valid after SCL low	0	3.45 <sup>(2)</sup>	0	0.9	$\mu$ s
$t_{w(SDAH)}$	Pulse duration, SDA high between STOP and START conditions	4.7		1.3		$\mu$ s
$t_{su(SCLH-SDAH)}$	Setup time, SCL high before SDA high (for STOP condition)	4.0		0.6		$\mu$ s
$t_{w(SP)}$	Pulse duration, spike (must be suppressed)			0	50	ns
$C_b$ <sup>(3)</sup>	Capacitive load for each bus line		400		400	pF

- (1) The I2C pins SDA and SCL do not feature fail-safe I/O buffers. These pins could potentially draw current when the device is powered down.
- (2) The maximum  $t_{h(SDA-SCLL)}$  for I2C bus devices needs only be met if the device does not stretch the low period ( $t_{w(SCLL)}$ ) of the SCL signal.
- (3)  $C_b$  = The total capacitance of one bus line in pF.

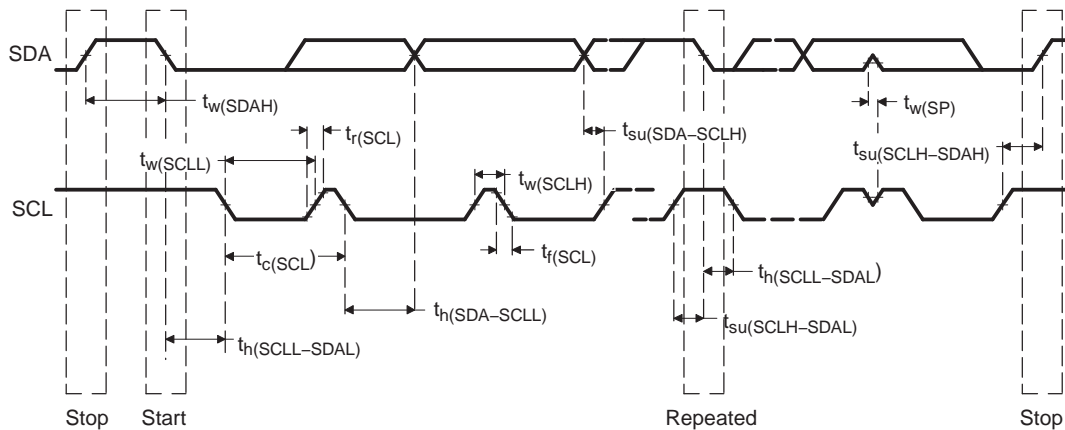

- A. A device must internally provide a hold time of at least 300 ns for the SDA signal (referred to the  $V_{IHmin}$  of the SCL signal) to bridge the undefined region of the falling edge of SCL.
- B. The maximum  $t_{h(SDA-SCLL)}$  needs only be met if the device does not stretch the LOW period ( $t_{w(SCLL)}$ ) of the SCL signal.
- C. A fast-mode I2C-bus device can be used in a standard-mode I2C-bus system, but the requirement  $t_{su(SDA-SCLH)} \geq 250$  ns must then be met. This will automatically be the case if the device does not stretch the LOW period of the SCL signal. If such a device does stretch the LOW period of the SCL signal, it must output the next data bit to the SDA line  $t_r \max + t_{su(SDA-SCLH)}$ .
- D.  $C_b$  = total capacitance of one bus line in pF. If mixed with HS-mode devices, faster fall-times are allowed.

**Figure 19. I2C Timings**

## STANDARD CAN CONTROLLER (SCC) MODE TIMINGS

### Dynamic Characteristics for the CANSTX and CANSRX Pins

PARAMETER		MIN	MAX	UNIT
$t_d(\text{CANSTX})$	Delay time, transmit shift register to CANSTX pin <sup>(1)</sup>		15	ns
$t_d(\text{CANSRX})$	Delay time, CANSRX pin to receive shift register		5	ns

(1) These values do not include the rise/fall times of the output buffer.

**EXPANSION BUS MODULE TIMING**

**Expansion Bus Timing Parameters,  $-40^{\circ}\text{C} \leq T_J \leq 150^{\circ}\text{C}$ ,  $3.0\text{ V} \leq V_{CC} \leq 3.6\text{ V}$**

(see [Figure 20](#) and [Figure 21](#))

		MIN	MAX	UNIT
$t_{c(\text{CO})}$	Cycle time, CLKOUT	20.8		ns
$t_{d(\text{COH-EBADV})}$	Delay time, CLKOUT high to EBADDR valid		21.4	ns
$t_{h(\text{COH-EBADIV})}$	Hold time, EBADDR invalid after CLKOUT high		12.4	ns
$t_{d(\text{COH-EBOE})}$	Delay time, CLKOUT high to $\overline{\text{EBOE}}$ fall		11.4	ns
$t_{h(\text{COH-EBOEH})}$	Hold time, $\overline{\text{EBOE}}$ rise after CLKOUT high		11.4	ns
$t_{d(\text{COL-EBWR})}$	Delay time, CLKOUT low to write strobe ( $\overline{\text{EBWR}}$ ) low		11.3	ns
$t_{h(\text{COL-EBWRH})}$	Hold time, $\overline{\text{EBWR}}$ high after CLKOUT low		11.6	ns
$t_{\text{su}}(\text{EBRDATV-COH})$	Setup time, EBDATA valid before CLKOUT high (READ) <sup>(1)</sup>	15.2		ns
$t_{h(\text{COH-EBRDATIV})}$	Hold time, EBDATA invalid after CLKOUT high (READ)		(-14.7)	ns
$t_{d(\text{COL-EBWDATV})}$	Delay time, CLKOUT low to EBDATA valid (WRITE) <sup>(2)</sup>		16.1	ns
$t_{h(\text{COL-EBWDATIV})}$	Hold time, EBDATA invalid after CLKOUT low (WRITE)		14.7	ns
<b>SECONDARY TIMES</b>				
$t_{d(\text{COH-EBCS0})}$	Delay, CLKOUT high to $\overline{\text{EBCS0}}$ fall		13.6	ns
$t_{h(\text{COH-EBCS0H})}$	Hold, $\overline{\text{EBCS0}}$ rise after CLKOUT high		13.2	ns
$t_{\text{su}}(\text{COH-EBHOLDL})$	Setup time, $\overline{\text{EBHOLD}}$ low to CLKOUT high <sup>(1)</sup>	10.9		ns
$t_{\text{su}}(\text{COH-EBHOLDH})$	Setup time, $\overline{\text{EBHOLD}}$ high to CLKOUT high <sup>(1)</sup>	10.5		ns

- (1) Setup time is the minimum time under worst case conditions. Data with less setup time will not work.
- (2) Valid after CLKOUT goes low for write cycles.

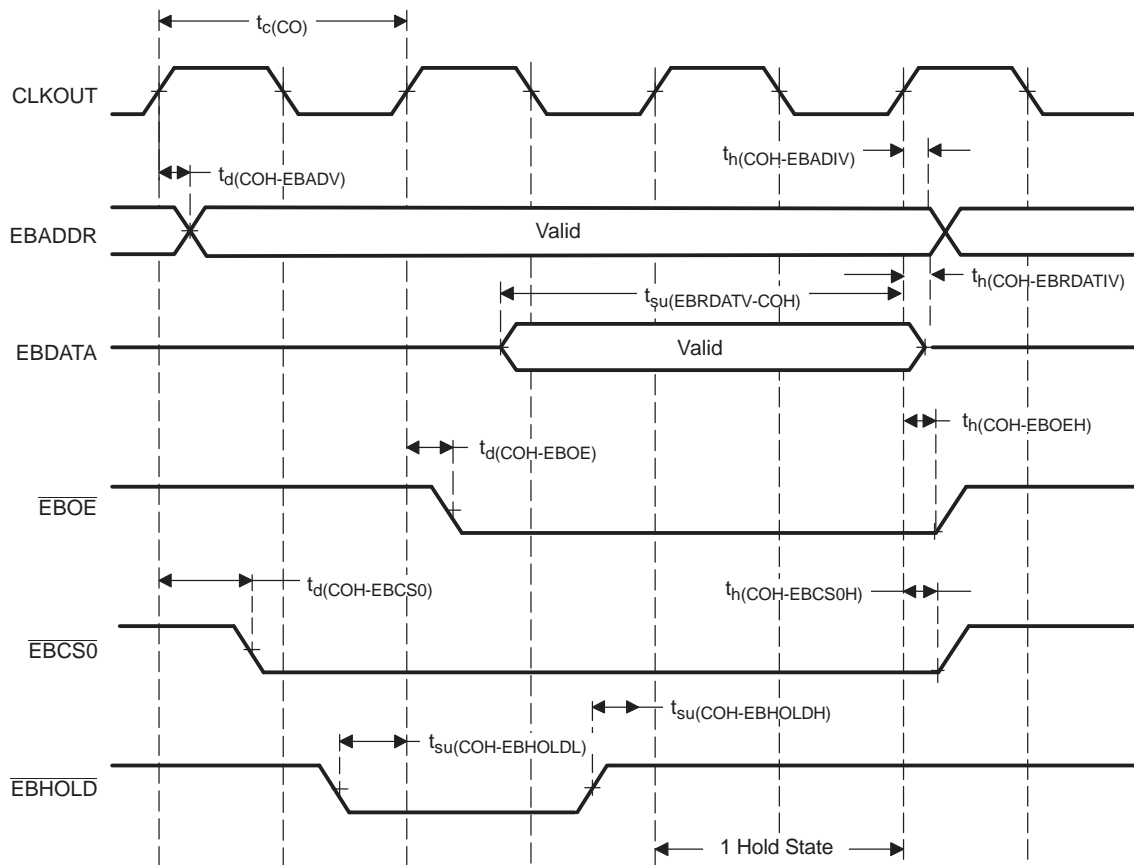

**Figure 20. Expansion Memory Signal Timing - Reads**

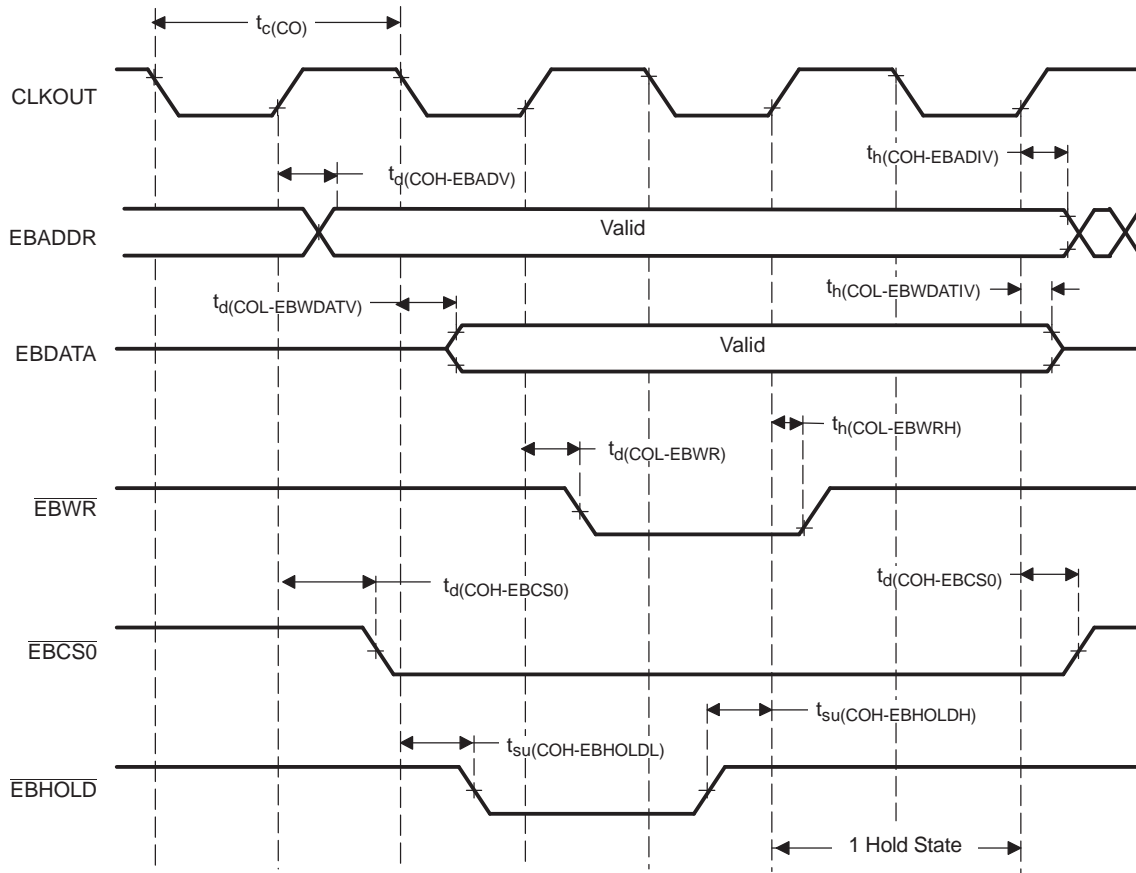

**Figure 21. Expansion Memory Signal Timing - Writes**

---

## HIGH-END TIMER (HET) TIMINGS

### Minimum PWM Output Pulse Width:

This is equal to one high resolution clock period (HRP). The HRP is defined by the 6-bit high resolution prescale factor (hr), which is user defined, giving prescale factors of 1 to 64, with a linear increment of codes.

Therefore, the minimum PWM output pulse width =  $HRP(\min) = hr(\min)/SYSCLK = 1/SYSCLK$

For example, for a SYSCLK of 30 MHz, the minimum PWM output pulse width =  $1/30 = 33.33\text{ns}$

### Minimum Input Pulses that Can Be Captured:

The input pulse width must be greater or equal to the low resolution clock period (LRP), i.e., the HET loop (the HET program must fit within the LRP). The LRP is defined by the 3-bit loop-resolution prescale factor (lr), which is user defined, with a power of 2 increment of codes. That is, the value of lr can be 1, 2, 4, 8, 16, or 32.

Therefore, the minimum input pulse width =  $LRP(\min) = hr(\min) * lr(\min)/SYSCLK = 1 * 1/SYSCLK$

For example, with a SYSCLK of 30 MHz, the minimum input pulse width =  $1 * 1/30 = 33.33 \text{ ns}$

### NOTE:

Once the input pulse width is greater than LRP, the resolution of the measurement is still HRP. (That is, the captured value gives the number of HRP clocks inside the pulse.)

Abbreviations:

hr = HET high resolution divide rate = 1, 2, 3,...63, 64

lr = HET low resolution divide rate = 1, 2, 4, 8, 16, 32

High resolution clock period =  $HRP = hr/SYSCLK$

Loop resolution clock period =  $LRP = hr*lr/SYSCLK$

### MULTI-BUFFERED A-TO-D CONVERTER (MibADC)

The multi-buffered A-to-D converter (MibADC) has a separate power bus for its analog circuitry that enhances the A-to-D performance by preventing digital switching noise on the logic circuitry, which could be present on  $V_{SS}$  and  $V_{CC}$ , from coupling into the A-to-D analog stage. All A-to-D specifications are given with respect to  $AD_{REFLO}$  unless otherwise noted.

Resolution 10 bits (1024 values)  
 Monotonic Assured  
 Output conversion code 00h to 3FFh [00 for  $V_{AI} \leq AD_{REFLO}$ ; 3FF for  $V_{AI} \geq AD_{REFHI}$ ]

**Table 12. MibADC Recommended Operating Conditions<sup>(1)</sup>**

		MIN	MAX	UNIT
$AD_{REFHI}$	A-to-D high-voltage reference source	$V_{SSAD}$	$V_{CCAD}$	V
$AD_{REFLO}$	A-to-D low-voltage reference source	$V_{SSAD}$	$V_{CCAD}$	V
$V_{AI}$	Analog input voltage	$V_{SSAD} - 0.3$	$V_{CCAD} + 0.3$	V
$I_{AIC}$	Analog input clamp current <sup>(2)</sup> ( $V_{AI} < V_{SSAD} - 0.3$ or $V_{AI} > V_{CCAD} + 0.3$ )	-2	2	mA

- (1) For  $V_{CCAD}$  and  $V_{SSAD}$  recommended operating conditions, see the "Device Recommended Operating Conditions" table.  
 (2) Input currents into any ADC input channel outside the specified limits could affect conversion results of other channels.

**Table 13. Operating Characteristics Over Full Ranges of Recommended Operating Conditions<sup>(1)(2)</sup>**

PARAMETER	DESCRIPTION/CONDITIONS	MIN	TYP	MAX	UNIT	
$R_i$	Analog input resistance	See <a href="#">Figure 22</a> .		250	500	$\Omega$
$C_i$	Analog input capacitance	See <a href="#">Figure 22</a> .			10	pF
		Conversion			30	pF
$I_{AIL}$	Analog input leakage current	See <a href="#">Figure 22</a> .		-1	1	$\mu$ A
$I_{ADREFHI}$	$AD_{REFHI}$ input current	$AD_{REFHI} = 3.6$ V, $AD_{REFLO} = V_{SSAD}$			5	mA
CR	Conversion range over which specified accuracy is maintained	$AD_{REFHI} - AD_{REFLO}$		3	3.6	V
$E_{DNL}$	Differential nonlinearity error	Difference between the actual step width and the ideal value. See <a href="#">Figure 23</a> .			$\pm 2$	LSB
$E_{INL}$	Integral nonlinearity error	Maximum deviation from the best straight line through the MibADC. MibADC transfer characteristics, excluding the quantization error. See <a href="#">Figure 24</a> .			$\pm 2$	LSB
$E_{TOT}$	Total error/absolute accuracy	Maximum value of the difference between an analog value and the ideal midstep value. See <a href="#">Figure 25</a> .			$\pm 2$	LSB

- (1)  $V_{CCAD} = AD_{REFHI}$   
 (2)  $1 \text{ LSB} = (AD_{REFHI} - AD_{REFLO}) / 2^{10}$  for the MibADC

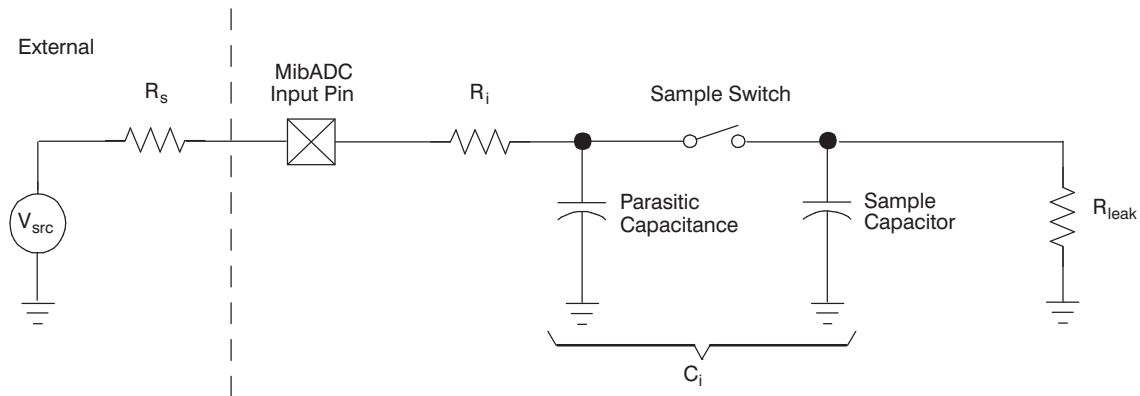

Figure 22. MibADC Input Equivalent Circuit

### Multi-Buffer ADC Timing Requirements

		MIN	NOM	MAX	UNIT
$t_{c(ADCLK)}$	Cycle time, MibADC clock	0.05			$\mu\text{s}$
$t_{d(SH)}$	Delay time, sample and hold time	1			$\mu\text{s}$
$t_{d(C)}$	Delay time, conversion time	0.55			$\mu\text{s}$
$t_{d(SHC)}^{(1)}$	Delay time, total sample/hold and conversion time	1.55			$\mu\text{s}$

(1) This is the minimum sample/hold and conversion time that can be achieved. These parameters are dependent on many factors; for more details, see the *TMS470R1x Multi-Buffered Analog-to-Digital Converter (MibADC) Reference Guide* (literature number SPNU206).

The differential nonlinearity error shown in Figure 23 (sometimes referred to as differential linearity) is the difference between an actual step width and the ideal value of 1 LSB.

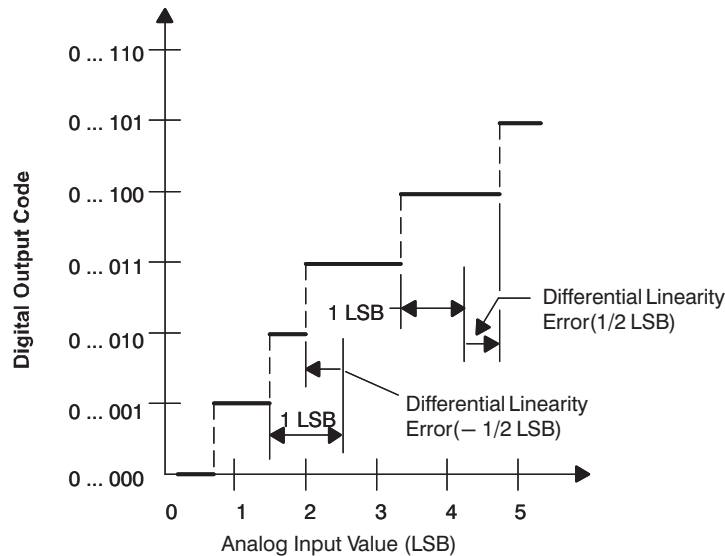

A.  $1 \text{ LSB} = (AD_{REFHI} - AD_{REFLO})/2^{10}$

Figure 23. Differential Nonlinearity (DNL)

The integral nonlinearity error shown in Figure 24 (sometimes referred to as linearity error) is the deviation of the values on the actual transfer function from a straight line.

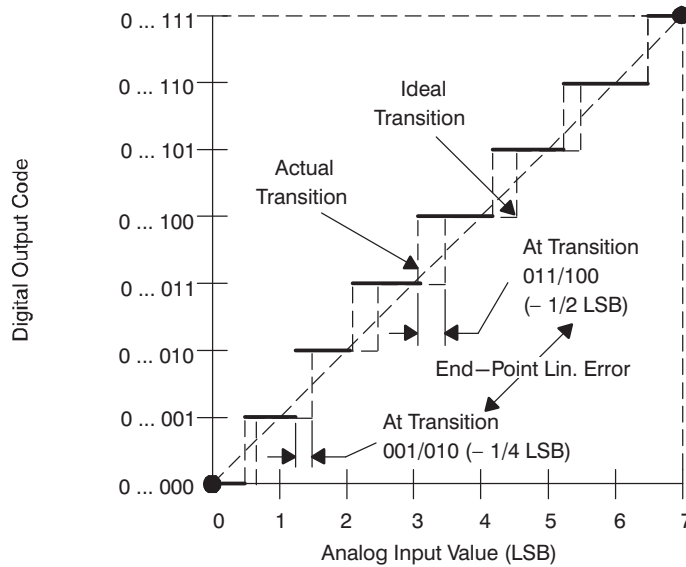

A.  $1 \text{ LSB} = (AD_{\text{REFHI}} - AD_{\text{REFLO}})/2^{10}$

**Figure 24. Integral Nonlinearity (INL) Error**

The absolute accuracy or total error of an MibADC as shown in Figure 25 is the maximum value of the difference between an analog value and the ideal midstep value.

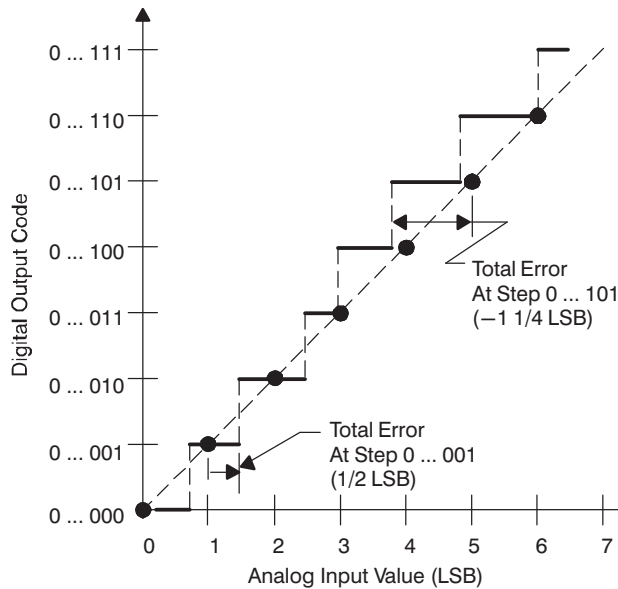

A.  $1 \text{ LSB} = (AD_{\text{REFHI}} - AD_{\text{REFLO}})/2^{10}$

**Figure 25. Absolute Accuracy (Total) Error**

**PGE Thermal Resistance Characteristics**

PARAMETER	°C/W
$R_{\theta JA}$	43
$R_{\theta JC}$	5

**PZ Thermal Resistance Characteristics**

PARAMETER	°C/W
$R_{\theta JA}$	48
$R_{\theta JC}$	5

### Revision History

NOTE: Page numbers for previous revisions may differ from page numbers in the current version.

This revision history highlights the changes made to the device-specific datasheet SPNS106.

**Table 14. Revision History**

<b>SPNS106A to SPNS106B</b>
Corrected names on pins 135 and 39 in pinout drawing on page 3.
Revised the Family Nomenclature drawing to add Q version of the temperature range.
Revised "Absolute Maximum Ratings" table to add Q version of the temperature range.
Revised "Device Recommended Operating Conditions" table to add Q version of the temperature range.
Added T and Q temperature rows to $I_{CC}$ , standby mode, specification in "Electrical Characteristics". Changed T temperature max to 1. Added Q temperature max of 1.25.
Added T and Q temperature rows to $I_{CC}$ , halt mode, specification in "Electrical Characteristics". Changed T temperature max to 355. Added Q temperature max of 550.
Added note to $\overline{PORRST}$ Timing Diagram.
Changed $T_A$ range to $-40^{\circ}\text{C}$ to $125^{\circ}\text{C}$ on $t_{wec}$ in "Timing Requirements for Program Flash" table.
Added $t_{wec}$ MIN value of 50000 and deleted MAX value in "Timing Requirements for Program Flash" table.
Changed $t_{erase(sector)}$ TYP value to 1.7 and removed MAX value in "Timing Requirements for Program Flash" table.
<b>SPNS106 to SPNS106A</b>
Changed "Industrial Temperature Range" to "Extended Industrial Temperature Range."
Corrected temperature range in Family Nomenclature drawing to read $-40^{\circ}\text{C}$ to $105^{\circ}\text{C}$ .
Corrected Absolute Maximum Ratings table to T version of temperature. Changed operating free-air temperature range to T version, $-40^{\circ}\text{C}$ to $105^{\circ}\text{C}$ .
In Device Recommended Operating Conditions table, changed temperature range to T version, $-40^{\circ}\text{C}$ to $105^{\circ}\text{C}$ .
Changed $I_{CC}$ standby mode and halt mode maximums to 1.25 mA and 550 $\mu\text{A}$ , respectively.
Changed minimum in row No. 4 in SPIn Master Mode External Timing Parameters table, $t_{V(SIMO=SPCH)M}$ .

**PACKAGING INFORMATION**

Orderable Device	Status (1)	Package Type	Package Drawing	Pins	Package Qty	Eco Plan (2)	Lead/Ball Finish (6)	MSL Peak Temp (3)	Op Temp (°C)	Device Marking (4/5)	Samples
TMS470R1A288PGEA	NRND	LQFP	PGE	144	60	Green (RoHS & no Sb/Br)	CU NIPDAU	Level-3-260C-168 HR		470R1A288PGEA TMS	
TMS470R1A288PGET	NRND	LQFP	PGE	144	60	Green (RoHS & no Sb/Br)	CU NIPDAU	Level-3-260C-168 HR		470R1A288PGET TMS	
TMS470R1A288PGETR	NRND	LQFP	PGE	144	500	Green (RoHS & no Sb/Br)	CU NIPDAU	Level-3-260C-168 HR		470R1A288PGET TMS	
TMS470R1A288PZ-T	NRND	LQFP	PZ	100	90	Green (RoHS & no Sb/Br)	CU NIPDAU	Level-3-260C-168 HR		470R1A288PZ-T TMS	

(1) The marketing status values are defined as follows:

**ACTIVE:** Product device recommended for new designs.

**LIFEBUY:** TI has announced that the device will be discontinued, and a lifetime-buy period is in effect.

**NRND:** Not recommended for new designs. Device is in production to support existing customers, but TI does not recommend using this part in a new design.

**PREVIEW:** Device has been announced but is not in production. Samples may or may not be available.

**OBsolete:** TI has discontinued the production of the device.

(2) **RoHS:** TI defines "RoHS" to mean semiconductor products that are compliant with the current EU RoHS requirements for all 10 RoHS substances, including the requirement that RoHS substance do not exceed 0.1% by weight in homogeneous materials. Where designed to be soldered at high temperatures, "RoHS" products are suitable for use in specified lead-free processes. TI may reference these types of products as "Pb-Free".

**RoHS Exempt:** TI defines "RoHS Exempt" to mean products that contain lead but are compliant with EU RoHS pursuant to a specific EU RoHS exemption.

**Green:** TI defines "Green" to mean the content of Chlorine (Cl) and Bromine (Br) based flame retardants meet JS709B low halogen requirements of <=1000ppm threshold. Antimony trioxide based flame retardants must also meet the <=1000ppm threshold requirement.

(3) MSL, Peak Temp. - The Moisture Sensitivity Level rating according to the JEDEC industry standard classifications, and peak solder temperature.

(4) There may be additional marking, which relates to the logo, the lot trace code information, or the environmental category on the device.

(5) Multiple Device Markings will be inside parentheses. Only one Device Marking contained in parentheses and separated by a "-" will appear on a device. If a line is indented then it is a continuation of the previous line and the two combined represent the entire Device Marking for that device.

(6) Lead/Ball Finish - Orderable Devices may have multiple material finish options. Finish options are separated by a vertical ruled line. Lead/Ball Finish values may wrap to two lines if the finish value exceeds the maximum column width.

**Important Information and Disclaimer:** The information provided on this page represents TI's knowledge and belief as of the date that it is provided. TI bases its knowledge and belief on information provided by third parties, and makes no representation or warranty as to the accuracy of such information. Efforts are underway to better integrate information from third parties. TI has taken and

continues to take reasonable steps to provide representative and accurate information but may not have conducted destructive testing or chemical analysis on incoming materials and chemicals. TI and TI suppliers consider certain information to be proprietary, and thus CAS numbers and other limited information may not be available for release.

In no event shall TI's liability arising out of such information exceed the total purchase price of the TI part(s) at issue in this document sold by TI to Customer on an annual basis.

PZ (S-PQFP-G100)

PLASTIC QUAD FLATPACK

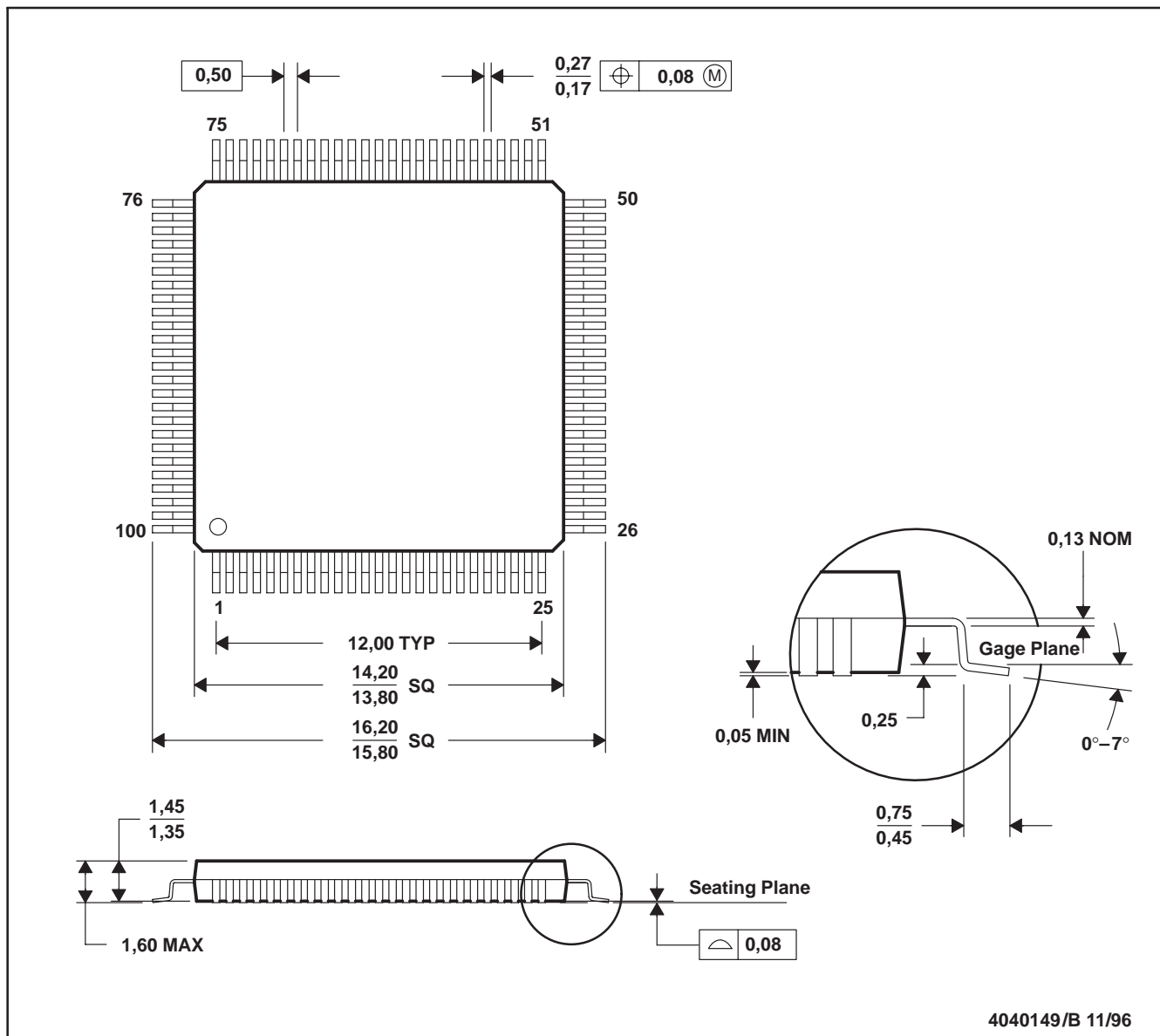

4040149/B 11/96

- NOTES: A. All linear dimensions are in millimeters.  
 B. This drawing is subject to change without notice.  
 C. Falls within JEDEC MS-026

PZ (S-PQFP-G100)

PLASTIC QUAD FLAT PACK

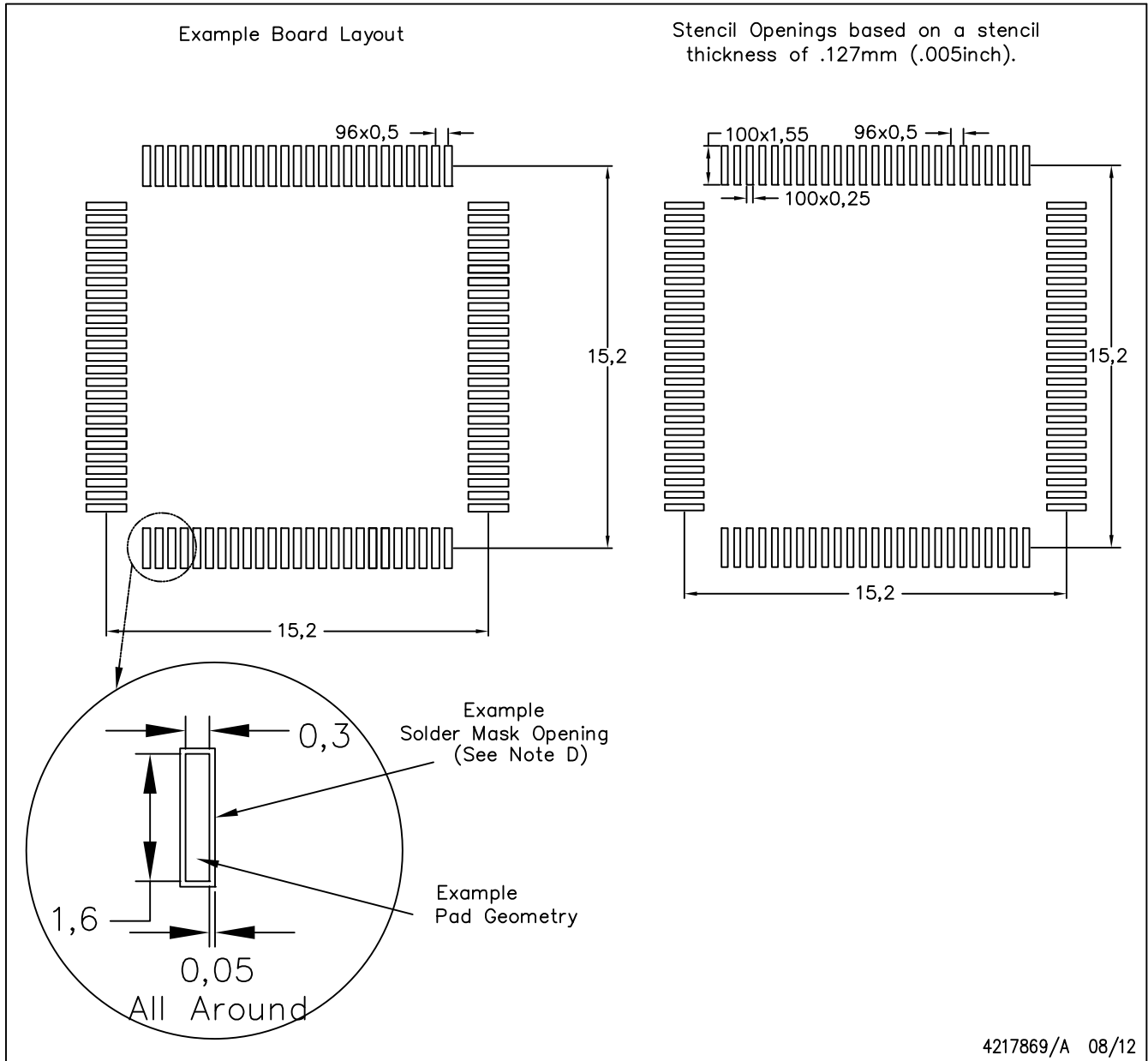

NOTES:

- All linear dimensions are in millimeters.
- This drawing is subject to change without notice.
- Laser cutting apertures with trapezoidal walls and also rounding corners will offer better paste release. Customers should contact their board assembly site for stencil design recommendations. Example stencil design based on a 50% volumetric metal load solder paste. Refer to IPC-7525 for other stencil recommendations.
- Customers should contact their board fabrication site for solder mask tolerances between and around signal pads.

PGE (S-PQFP-G144)

PLASTIC QUAD FLATPACK

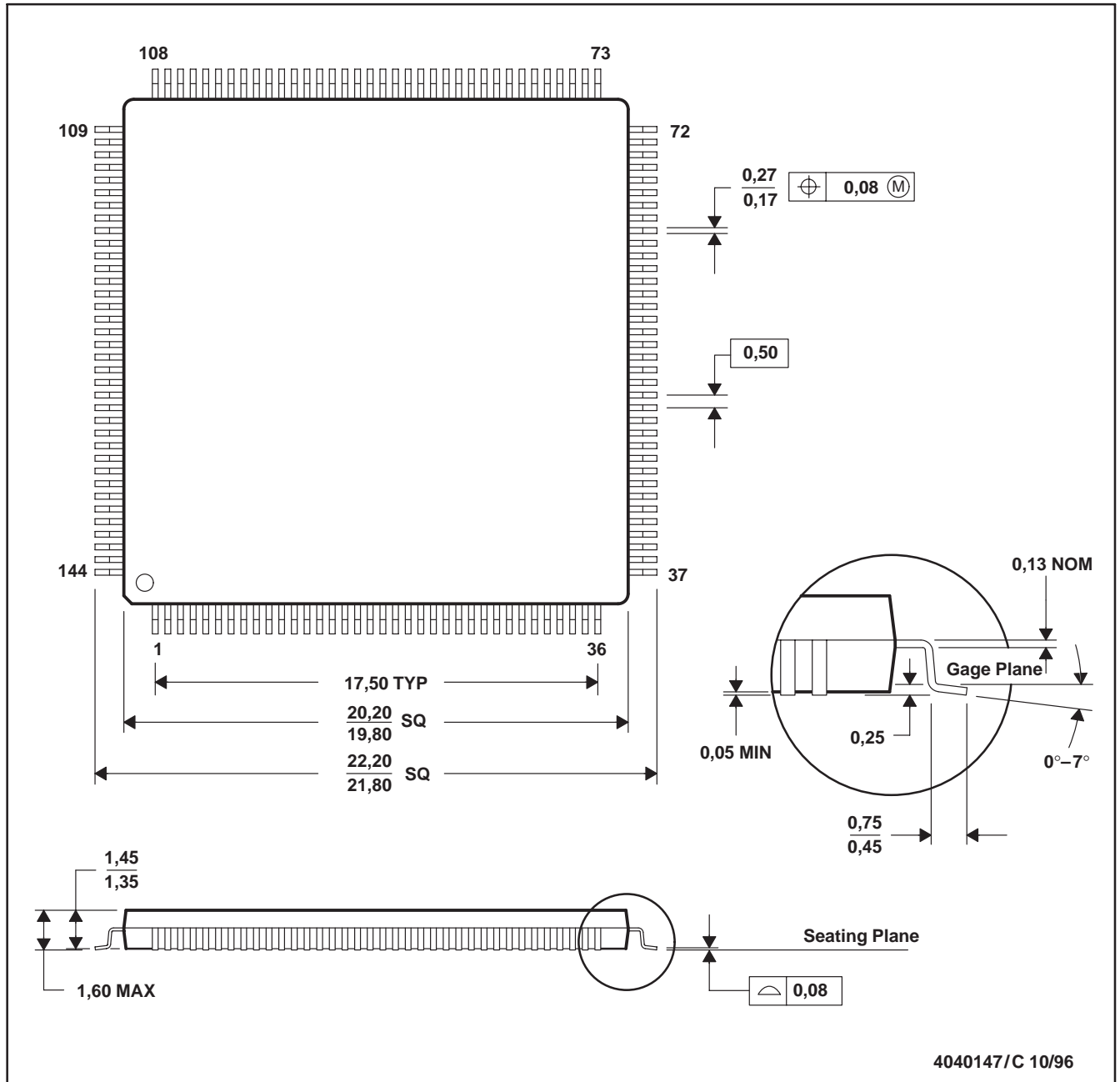

- NOTES: A. All linear dimensions are in millimeters.  
 B. This drawing is subject to change without notice.  
 C. Falls within JEDEC MS-026

## IMPORTANT NOTICE

Texas Instruments Incorporated (TI) reserves the right to make corrections, enhancements, improvements and other changes to its semiconductor products and services per JESD46, latest issue, and to discontinue any product or service per JESD48, latest issue. Buyers should obtain the latest relevant information before placing orders and should verify that such information is current and complete.

TI's published terms of sale for semiconductor products (<http://www.ti.com/sc/docs/stdterms.htm>) apply to the sale of packaged integrated circuit products that TI has qualified and released to market. Additional terms may apply to the use or sale of other types of TI products and services.

Reproduction of significant portions of TI information in TI data sheets is permissible only if reproduction is without alteration and is accompanied by all associated warranties, conditions, limitations, and notices. TI is not responsible or liable for such reproduced documentation. Information of third parties may be subject to additional restrictions. Resale of TI products or services with statements different from or beyond the parameters stated by TI for that product or service voids all express and any implied warranties for the associated TI product or service and is an unfair and deceptive business practice. TI is not responsible or liable for any such statements.

Buyers and others who are developing systems that incorporate TI products (collectively, "Designers") understand and agree that Designers remain responsible for using their independent analysis, evaluation and judgment in designing their applications and that Designers have full and exclusive responsibility to assure the safety of Designers' applications and compliance of their applications (and of all TI products used in or for Designers' applications) with all applicable regulations, laws and other applicable requirements. Designer represents that, with respect to their applications, Designer has all the necessary expertise to create and implement safeguards that (1) anticipate dangerous consequences of failures, (2) monitor failures and their consequences, and (3) lessen the likelihood of failures that might cause harm and take appropriate actions. Designer agrees that prior to using or distributing any applications that include TI products, Designer will thoroughly test such applications and the functionality of such TI products as used in such applications.

TI's provision of technical, application or other design advice, quality characterization, reliability data or other services or information, including, but not limited to, reference designs and materials relating to evaluation modules, (collectively, "TI Resources") are intended to assist designers who are developing applications that incorporate TI products; by downloading, accessing or using TI Resources in any way, Designer (individually or, if Designer is acting on behalf of a company, Designer's company) agrees to use any particular TI Resource solely for this purpose and subject to the terms of this Notice.

TI's provision of TI Resources does not expand or otherwise alter TI's applicable published warranties or warranty disclaimers for TI products, and no additional obligations or liabilities arise from TI providing such TI Resources. TI reserves the right to make corrections, enhancements, improvements and other changes to its TI Resources. TI has not conducted any testing other than that specifically described in the published documentation for a particular TI Resource.

Designer is authorized to use, copy and modify any individual TI Resource only in connection with the development of applications that include the TI product(s) identified in such TI Resource. NO OTHER LICENSE, EXPRESS OR IMPLIED, BY ESTOPPEL OR OTHERWISE TO ANY OTHER TI INTELLECTUAL PROPERTY RIGHT, AND NO LICENSE TO ANY TECHNOLOGY OR INTELLECTUAL PROPERTY RIGHT OF TI OR ANY THIRD PARTY IS GRANTED HEREIN, including but not limited to any patent right, copyright, mask work right, or other intellectual property right relating to any combination, machine, or process in which TI products or services are used. Information regarding or referencing third-party products or services does not constitute a license to use such products or services, or a warranty or endorsement thereof. Use of TI Resources may require a license from a third party under the patents or other intellectual property of the third party, or a license from TI under the patents or other intellectual property of TI.

TI RESOURCES ARE PROVIDED "AS IS" AND WITH ALL FAULTS. TI DISCLAIMS ALL OTHER WARRANTIES OR REPRESENTATIONS, EXPRESS OR IMPLIED, REGARDING RESOURCES OR USE THEREOF, INCLUDING BUT NOT LIMITED TO ACCURACY OR COMPLETENESS, TITLE, ANY EPIDEMIC FAILURE WARRANTY AND ANY IMPLIED WARRANTIES OF MERCHANTABILITY, FITNESS FOR A PARTICULAR PURPOSE, AND NON-INFRINGEMENT OF ANY THIRD PARTY INTELLECTUAL PROPERTY RIGHTS. TI SHALL NOT BE LIABLE FOR AND SHALL NOT DEFEND OR INDEMNIFY DESIGNER AGAINST ANY CLAIM, INCLUDING BUT NOT LIMITED TO ANY INFRINGEMENT CLAIM THAT RELATES TO OR IS BASED ON ANY COMBINATION OF PRODUCTS EVEN IF DESCRIBED IN TI RESOURCES OR OTHERWISE. IN NO EVENT SHALL TI BE LIABLE FOR ANY ACTUAL, DIRECT, SPECIAL, COLLATERAL, INDIRECT, PUNITIVE, INCIDENTAL, CONSEQUENTIAL OR EXEMPLARY DAMAGES IN CONNECTION WITH OR ARISING OUT OF TI RESOURCES OR USE THEREOF, AND REGARDLESS OF WHETHER TI HAS BEEN ADVISED OF THE POSSIBILITY OF SUCH DAMAGES.

Unless TI has explicitly designated an individual product as meeting the requirements of a particular industry standard (e.g., ISO/TS 16949 and ISO 26262), TI is not responsible for any failure to meet such industry standard requirements.

Where TI specifically promotes products as facilitating functional safety or as compliant with industry functional safety standards, such products are intended to help enable customers to design and create their own applications that meet applicable functional safety standards and requirements. Using products in an application does not by itself establish any safety features in the application. Designers must ensure compliance with safety-related requirements and standards applicable to their applications. Designer may not use any TI products in life-critical medical equipment unless authorized officers of the parties have executed a special contract specifically governing such use. Life-critical medical equipment is medical equipment where failure of such equipment would cause serious bodily injury or death (e.g., life support, pacemakers, defibrillators, heart pumps, neurostimulators, and implantables). Such equipment includes, without limitation, all medical devices identified by the U.S. Food and Drug Administration as Class III devices and equivalent classifications outside the U.S.

TI may expressly designate certain products as completing a particular qualification (e.g., Q100, Military Grade, or Enhanced Product). Designers agree that it has the necessary expertise to select the product with the appropriate qualification designation for their applications and that proper product selection is at Designers' own risk. Designers are solely responsible for compliance with all legal and regulatory requirements in connection with such selection.

Designer will fully indemnify TI and its representatives against any damages, costs, losses, and/or liabilities arising out of Designer's non-compliance with the terms and provisions of this Notice.

## Looking for pricing, stock, or lifecycle information?

Click below to explore more details on WIN SOURCE:

 [View TMS470R1A288PGEA on WIN SOURCE](#)

 [Texas Instruments](#) Information

## Optimize Your Supply Chain with WIN SOURCE Solutions

-  Global Sourcing Solution
-  Obsolete Management
-  Cost Control Management
-  Shortage Management
-  Alternative Solution
-  Excess Inventory Management